

Rules for the Classification of Inland Waterway Ships and for Conformity to Directive 2016/1629/EU

Effective from 1 March 2019

Part D

Materials and Welding

Emirates Classification Society (Tasneef)
Aldar HQ 19th Floor,
Al Raha Beach, Abu Dhabi, UAE
Abu Dhabi, United Arab Emirates

Phone (+971) 2 692 2333
Fax (+971) 2 445 433
P.O. Box. 111155
info@tasneef.ae

GENERAL CONDITIONS

Definitions:

"Administration" means the Government of the State whose flag the Ship is entitled to fly or under whose authority the Ship is authorised to operate in the specific case.

"IACS" means the International Association of Classification Societies.

"Interested Party" means the party, other than the Society, having an interest in or responsibility for the Ship, product, plant or system subject to classification or certification (such as the owner of the Ship and his representatives, the ship builder, the engine builder or the supplier of parts to be tested) who requests the Services or on whose behalf the Services are requested.

"Owner" means the registered owner, the ship owner, the manager or any other party with the responsibility, legally or contractually, to keep the ship seaworthy or in service, having particular regard to the provisions relating to the maintenance of class laid down in Part A, Chapter 2 of the Rules for the Classification of Ships or in the corresponding rules indicated in the specific Rules.

"Rules" in these General Conditions means the documents below issued by the Society:

- (i) Rules for the Classification of Ships or other special units;
- (ii) Complementary Rules containing the requirements for product, plant, system and other certification or containing the requirements for the assignment of additional class notations;
- (iii) Rules for the application of statutory rules, containing the rules to perform the duties delegated by Administrations;
- (iv) Guides to carry out particular activities connected with Services;
- (v) Any other technical document, as for example rule variations or interpretations.

"Services" means the activities described in Article 1 below, rendered by the Society upon request made by or on behalf of the Interested Party.

"Ship" means ships, boats, craft and other special units, as for example offshore structures, floating units and underwater craft.

"Society" or "TASNEEF" means Tasneef and/or all the companies in the Tasneef Group which provide the Services.

"Surveyor" means technical staff acting on behalf of the Society in performing the Services.

Article 1

1.1. The purpose of the Society is, among others, the classification and certification of ships and the certification of their parts and components. In particular, the Society:

- (i) sets forth and develops Rules;
- (ii) publishes the Register of Ships;
- (iii) issues certificates, statements and reports based on its survey activities.

1.2. The Society also takes part in the implementation of national and international rules and standards as delegated by various Governments.

1.3. The Society carries out technical assistance activities on request and provides special services outside the scope of classification, which are regulated by these general conditions, unless expressly excluded in the particular contract.

Article 2

2.1. The Rules developed by the Society reflect the level of its technical knowledge at the time they are published. Therefore, the Society, although committed also through its research and development services to continuous updating of the Rules, does not guarantee the Rules meet state-of-the-art science and technology at the time of publication or that they meet the Society's or others' subsequent technical developments.

2.2. The Interested Party is required to know the Rules on the basis of which the Services are provided. With particular reference to Classification Services, special attention is to be given to the Rules concerning class suspension, withdrawal and reinstatement. In case of doubt or inaccuracy, the Interested Party is to promptly contact the Society for clarification.

The Rules for Classification of Ships are published on the Society's website: www.tasneef.ae.

2.3. The Society exercises due care and skill:

- (i) in the selection of its Surveyors
- (ii) in the performance of its Services, taking into account the level of its technical knowledge at the time the Services are performed.

2.4. Surveys conducted by the Society include, but are not limited to, visual inspection and non-destructive testing. Unless otherwise required, surveys are conducted through sampling techniques and do not consist of comprehensive verification or monitoring of the Ship or of the items subject to certification. The surveys and checks made by the Society on board ship do not necessarily require the constant and continuous presence of the Surveyor. The Society may also commission laboratory testing, underwater inspection and other checks carried out by and under the responsibility of qualified service suppliers. Survey practices and procedures are selected by the Society based on its experience and knowledge and according to generally accepted technical standards in the sector.

Article 3

3.1. The class assigned to a Ship, like the reports, statements, certificates or any other document or information issued by the Society, reflects the opinion of the Society concerning compliance, at the time the Service is provided, of the Ship or product subject to certification, with the applicable Rules (given the intended use and within the relevant time frame).

The Society is under no obligation to make statements or provide information about elements or facts which are not part of the specific scope of the Service requested by the Interested Party or on its behalf.

3.2. No report, statement, notation on a plan, review, Certificate of Classification, document or information issued or given as part of the Services provided by the Society shall have any legal effect or implication other than a representation that, on the basis of the checks made by the Society, the Ship, structure, materials, equipment, machinery or any other item covered by such document or information meet the Rules. Any such document is issued solely for the use of the Society, its committees and clients or other duly authorised bodies and for no other purpose. Therefore, the Society cannot be held liable for any act made or document issued by other parties on the basis of the statements or information given by the Society. The validity, application, meaning and interpretation of a Certificate of Classification, or any other document or information issued by the Society in connection with its Services, is governed by the Rules of the Society, which is the sole subject entitled to make such interpretation. Any disagreement on technical matters between the Interested Party and the Surveyor in the carrying out of his functions shall be raised in writing as soon as possible with the Society, which will settle any divergence of opinion or dispute.

3.3. The classification of a Ship, or the issuance of a certificate or other document connected with classification or certification and in general with the performance of Services by the Society shall have the validity conferred upon it by the Rules of the Society at the time of the assignment of class or issuance of the certificate; in no case shall it amount to a statement or warranty of seaworthiness,

structural integrity, quality or fitness for a particular purpose or service of any Ship, structure, material, equipment or machinery inspected or tested by the Society.

3.4. Any document issued by the Society in relation to its activities reflects the condition of the Ship or the subject of certification or other activity at the time of the check.

3.5. The Rules, surveys and activities performed by the Society, reports, certificates and other documents issued by the Society are in no way intended to replace the duties and responsibilities of other parties such as Governments, designers, ship builders, manufacturers, repairers, suppliers, contractors or sub-contractors, Owners, operators, charterers, underwriters, sellers or intended buyers of a Ship or other product or system surveyed.

These documents and activities do not relieve such parties from any fulfilment, warranty, responsibility, duty or obligation (also of a contractual nature) expressed or implied or in any case incumbent on them, nor do they confer on such parties any right, claim or cause of action against the Society. With particular regard to the duties of the ship Owner, the Services undertaken by the Society do not relieve the Owner of his duty to ensure proper maintenance of the Ship and ensure seaworthiness at all times. Likewise, the Rules, surveys performed, reports, certificates and other documents issued by the Society are intended neither to guarantee the buyers of the Ship, its components or any other surveyed or certified item, nor to relieve the seller of the duties arising out of the law or the contract, regarding the quality, commercial value or characteristics of the item which is the subject of transaction.

In no case, therefore, shall the Society assume the obligations incumbent upon the above-mentioned parties, even when it is consulted in connection with matters not covered by its Rules or other documents.

In consideration of the above, the Interested Party undertakes to relieve and hold harmless the Society from any third party claim, as well as from any liability in relation to the latter concerning the Services rendered.

Insofar as they are not expressly provided for in these General Conditions, the duties and responsibilities of the Owner and Interested Parties with respect to the services rendered by the Society are described in the Rules applicable to the specific Service rendered.

Article 4

4.1. Any request for the Society's Services shall be submitted in writing and signed by or on behalf of the Interested Party. Such a request will be considered irrevocable as soon as received by the Society and shall entail acceptance by the applicant of all relevant requirements of the Rules, including these General Conditions. Upon acceptance of the written request by the Society, a contract between the Society and the Interested Party is entered into, which is regulated by the present General Conditions.

4.2. In consideration of the Services rendered by the Society, the Interested Party and the person requesting the service shall be jointly liable for the payment of the relevant fees, even if the service is not concluded for any cause not pertaining to the Society. In the latter case, the Society shall not be held liable for non-fulfilment or partial fulfilment of the Services requested. In the event of late payment, interest at the legal current rate increased by 1.5% may be demanded.

4.3. The contract for the classification of a Ship or for other Services may be terminated and any certificates revoked at the request of one of the parties, subject to at least 30 days' notice to be given in writing. Failure to pay, even in part, the fees due for Services carried out by the Society will entitle the Society to immediately terminate the contract and suspend the Services.

For every termination of the contract, the fees for the activities performed until the time of the termination shall be owed to the Society as well as the expenses incurred in view of activities already programmed; this is without prejudice to the right to compensation due to the Society as a consequence of the termination.

With particular reference to Ship classification and certification, unless decided otherwise by the Society, termination of the contract implies that the assignment of class to a Ship is withheld or, if already assigned, that it is suspended or withdrawn; any statutory certificates issued by the Society will be withdrawn in those cases where provided for by agreements between the Society and the flag State.

Article 5

5.1. In providing the Services, as well as other correlated information or advice, the Society, its Surveyors, servants or agents operate with due diligence for the proper execution of the activity. However, considering the nature of the activities performed (see art. 2.4), it is not possible to guarantee absolute accuracy, correctness and completeness of any information or advice supplied. Express and implied warranties are specifically disclaimed.

Therefore, except as provided for in paragraph 5.2 below, and also in the case of activities carried out by delegation of Governments, neither the Society nor any of its Surveyors will be liable for any loss, damage or expense of whatever nature sustained by any person, in tort or in contract, derived from carrying out the Services.

5.2. Notwithstanding the provisions in paragraph 5.1 above, should any user of the Society's Services prove that he has suffered a loss or damage due to any negligent act or omission of the Society, its Surveyors, servants or agents, then the Society will pay compensation to such person for his proved loss, up to, but not exceeding, five times the amount of the fees charged for the specific services, information or opinions from which the loss or damage derives or, if no fee has been charged, a maximum of AED5,000 (Arab Emirates Dirhams Five Thousand only). Where the fees charged are related to a number of Services, the amount of the fees will be apportioned for the purpose of the calculation of the maximum compensation, by reference to the estimated time involved in the performance of the Service from which the damage or loss derives. Any liability for indirect or consequential loss, damage or expense is specifically excluded. In any case, irrespective of the amount of the fees charged, the maximum damages payable by the Society will not be more than AED5,000,000 (Arab Emirates Dirhams Five Millions only). Payment of compensation under this paragraph will not entail any admission of responsibility and/or liability by the Society and will be made without prejudice to the disclaimer clause contained in paragraph 5.1 above.

5.3. Any claim for loss or damage of whatever nature by virtue of the provisions set forth herein shall be made to the Society in writing, within the shorter of the following periods: (i) THREE (3) MONTHS from the date on which the Services were performed, or (ii) THREE (3) MONTHS from the date on which the damage was discovered. Failure to comply with the above deadline will constitute an absolute bar to the pursuit of such a claim against the Society.

Article 6

6.1. These General Conditions shall be governed by and construed in accordance with United Arab Emirates (UAE) law, and any dispute arising from or in connection with the Rules or with the Services of the Society, including any issues concerning responsibility, liability or limitations of liability of the Society, shall be determined in accordance with UAE law. The courts of the Dubai International Financial Centre (DIFC) shall have exclusive jurisdiction in relation to any claim or dispute which may arise out of or in connection with the Rules or with the Services of the Society.

6.2. However,

- (i) In cases where neither the claim nor any counterclaim exceeds the sum of AED300,000 (Arab Emirates Dirhams Three Hundred Thousand) the dispute shall be referred to the jurisdiction of the DIFC Small Claims Tribunal; and
- (ii) for disputes concerning non-payment of the fees and/or expenses due to the Society for services, the Society shall have the

right to submit any claim to the jurisdiction of the Courts of the place where the registered or operating office of the Interested Party or of the applicant who requested the Service is located.

In the case of actions taken against the Society by a third party before a public Court, the Society shall also have the right to summon the Interested Party or the subject who requested the Service before that Court, in order to be relieved and held harmless according to art. 3.5 above.

Article 7

7.1. All plans, specifications, documents and information provided by, issued by, or made known to the Society, in connection with the performance of its Services, will be treated as confidential and will not be made available to any other party other than the Owner without authorisation of the Interested Party, except as provided for or required by any applicable international, European or domestic legislation, Charter or other IACS resolutions, or order from a competent authority. Information about the status and validity of class and statutory certificates, including transfers, changes, suspensions, withdrawals of class, recommendations/conditions of class, operating conditions or restrictions issued against classed ships and other related information, as may be required, may be published on the website or released by other means, without the prior consent of the Interested Party.

Information about the status and validity of other certificates and statements may also be published on the website or released by other means, without the prior consent of the Interested Party.

7.2. Notwithstanding the general duty of confidentiality owed by the Society to its clients in clause 7.1 above, the Society's clients hereby accept that the Society may participate in the IACS Early Warning System which requires each Classification Society to provide other involved Classification Societies with relevant technical information on serious hull structural and engineering systems failures, as defined in the IACS Early Warning System (but not including any drawings relating to the ship which may be the specific property of another party), to enable such useful information to be shared and used to facilitate the proper working of the IACS Early Warning System. The Society will provide its clients with written details of such information sent to the involved Classification Societies.

7.3. In the event of transfer of class, addition of a second class or withdrawal from a double/dual class, the Interested Party undertakes to provide or to permit the Society to provide the other Classification Society with all building plans and drawings, certificates, documents and information relevant to the classed unit, including its history file, as the other Classification Society may require for the purpose of classification in compliance with the applicable legislation and relative IACS Procedure. It is the Owner's duty to ensure that, whenever required, the consent of the builder is obtained with regard to the provision of plans and drawings to the new Society, either by way of appropriate stipulation in the building contract or by other agreement.

In the event that the ownership of the ship, product or system subject to certification is transferred to a new subject, the latter shall have the right to access all pertinent drawings, specifications, documents or information issued by the Society or which has come to the knowledge of the Society while carrying out its Services, even if related to a period prior to transfer of ownership.

Article 8

8.1. Should any part of these General Conditions be declared invalid, this will not affect the validity of the remaining provisions.

Part D
Materials and Welding

Chapters **1 2 3 4 5**

Chapter 1	GENERAL REQUIREMENTS
Chapter 2	STEEL AND IRON PRODUCTS
Chapter 3	NON FERROUS METAL
Chapter 4	MISCELLANEOUS EQUIPMENT
Chapter 5	WELDING

CHAPTER 1

GENERAL REQUIREMENTS

Section 1 Manufacture, Inspection, Certification

1	General	23
1.1	Application	
1.2	Other specifications	
1.3	Information to be supplied by the purchaser	
2	Manufacture and quality	23
2.1	General	
2.2	Chemical composition	
2.3	Condition of supply	
2.4	Identification of products	
3	Inspection and testing	24
3.1	General conditions	
3.2	Alternative inspection scheme	
3.3	Sampling for mechanical tests	
3.4	Mechanical tests	
3.5	Re-test procedures	
3.6	Visual and dimensional examinations and non-destructive tests	
3.7	Repairs of defects	
4	Identification and certification	26
4.1	Identification and marking	
4.2	Documentation and certification	

Section 2 Testing Procedures for Materials

1	General	28
1.1	Application	
1.2	Testing machines	
1.3	Preparation of test specimens	
2	Tensile test	28
2.1	Test specimens	
2.2	Testing procedure	
3	Bend test	31
3.1	Flat bend test specimen	
3.2	Testing procedure	
4	Impact test	32
4.1	Sampling	
4.2	Charpy V-notch specimens	
4.3	Testing procedure	
4.4	Re-test procedure	
5	Drop weight test	33
5.1	Definition and specimens dimensions	
5.2	Testing procedure	

6	CTOD test (crack tip opening displacement test)	33
	6.1	
7	Ductility tests for pipes and tubes	33
	7.1 Flattening test	
	7.2 Drift expanding test	
	7.3 Flanging test	
	7.4 Ring expanding test	
	7.5 Ring tensile test	
	7.6 Bend test on pipes and tubes	
8	Other tests and checks	35
	8.1 Strain age embrittlement test	
	8.2 Macrographic and micrographic examinations	

CHAPTER 2

STEEL AND IRON PRODUCTS

Section 1 Rolled Steel Plates, Sections and Bars

1	General	39
1.1	Application	
1.2	Manufacture	
1.3	Approval	
1.4	Quality of materials	
1.5	Visual, dimensional and non-destructive examinations	
1.6	Rectification of surface defects	
1.7	Condition of supply	
1.8	Sampling and tests	
1.9	Identification and marking	
1.10	Documentation and certification	
2	Normal and higher strength steels for hull and other structural applications	42
2.1	Application	
2.2	Steel grades	
2.3	Manufacture	
2.4	Condition of supply	
2.5	Chemical composition	
2.6	Mechanical Properties	
2.7	Mechanical Tests	
3	High strength quenched and tempered steels	48
3.1	Application	
3.2	Steel grades	
3.3	Manufacture	
3.4	Condition of supply	
3.5	Chemical composition	
3.6	Mechanical properties	
3.7	Mechanical tests	
4	Steels for boilers and pressure vessels	49
4.1	Application	
4.2	Steel grades	
4.3	Manufacture	
4.4	Condition of supply	
4.5	Chemical composition	
4.6	Mechanical properties	
4.7	Mechanical properties at elevated temperatures	
4.8	Mechanical tests	
5	Ferritic steels for low temperature service	54
5.1	Application	
5.2	Steel grades	
5.3	Manufacture	
5.4	Condition of supply	
5.5	Chemical composition	
5.6	Mechanical properties	
5.7	Mechanical tests	

6	Steels for machinery	57
	6.1 Application	
	6.2 Steel grades and relevant properties	
	6.3 Manufacture and condition of supply	
	6.4 Mechanical tests	
7	Stainless steel products	58
	7.1 Application	
	7.2 Steel grades	
	7.3 Manufacture	
	7.4 Condition of supply	
	7.5 Chemical composition	
	7.6 Mechanical properties	
	7.7 Mechanical tests	
	7.8 Metallographic structure inspection	
	7.9 Intergranular corrosion test	
	7.10 Through thickness tests	
8	Clad steel plates	60
	8.1 Application	
	8.2 Steel grades	
	8.3 Manufacture	
	8.4 Condition of supply	
	8.5 Chemical composition	
	8.6 Mechanical properties	
	8.7 Mechanical tests	
	8.8 Corrosion testing	
	8.9 Ultrasonic testing	
	8.10 Surface defects and repairs	
	8.11 Adhesion defects in the cladding and repairs	
9	Steels with specified through thickness properties	62
	9.1 Application	
	9.2 Steel grades	
	9.3 Manufacture	
	9.4 Chemical composition	
	9.5 Mechanical properties	
	9.6 Test Procedure	
	9.7 Tensile test results	
	9.8 Re-test procedure	
	9.9 Ultrasonic testing	
	9.10 Marking	
	9.11 Certification	

Section 2 Steel Pipes, Tubes and Fittings

1	General	65
	1.1 Application	
	1.2 Manufacture	
	1.3 Approval	
	1.4 Quality of materials	
	1.5 Visual, dimensional and non-destructive examinations	
	1.6 Rectification of surface defects	
	1.7 Condition of supply	
	1.8 Hydrostatic test	

	1.9	Sampling and testing	
	1.10	Identification and marking	
	1.11	Documentation and certification	
2		Pipes for pressure systems operating at ambient temperature	67
	2.1	Application	
	2.2	Steel grades	
	2.3	Condition of supply	
	2.4	Chemical composition	
	2.5	Mechanical properties	
	2.6	Mechanical and technological tests	
3		Pipes for structural applications	68
	3.1	Application	
	3.2	Steel grades	
4		Pipes for high temperature service	68
	4.1	Application	
	4.2	Steel grades	
	4.3	Condition of supply	
	4.4	Chemical composition	
	4.5	Mechanical properties	
	4.6	Mechanical properties at elevated temperatures	
	4.7	Mechanical and technological tests	
5		Ferritic steel pipes for pressure service at low temperature	71
	5.1	Application	
	5.2	Steel grades	
	5.3	Condition of supply	
	5.4	Chemical composition	
	5.5	Mechanical properties	
	5.6	Mechanical and technological tests	
6		Austenitic and austenitic-ferritic stainless steel pipes	73
	6.1	Application	
	6.2	Steel grades	
	6.3	Condition of supply	
	6.4	Chemical composition	
	6.5	Mechanical properties	
	6.6	Mechanical and technological tests	
	6.7	Corrosion tests	
7		Fittings	75
	7.1	Application	
	7.2	Steel grades and relevant properties	
	7.3	Condition of supply	
	7.4	Mechanical properties	
	7.5	Mechanical and technological tests	
	7.6	Non-destructive examination	
	7.7	Marking and certification	

Section 3 Steel Forgings

1	General	76
	1.1 Application	
	1.2 Classification of forgings	
	1.3 Manufacture	
	1.4 Approval	
	1.5 Quality of materials	
	1.6 Visual and dimensional examination	
	1.7 Non-destructive examination	
	1.8 Rectification of defects	
	1.9 Condition of supply	
	1.10 Pressure test	
	1.11 Sampling and testing	
	1.12 Identification and marking	
	1.13 Documentation and certification	
2	Forgings for hull and other welded structures in general	80
	2.1 Application	
	2.2 Steel grades	
	2.3 Condition of supply	
	2.4 Chemical composition	
	2.5 Mechanical properties	
	2.6 Mechanical tests	
	2.7 Non-destructive examination	
3	Forgings for machinery, shafts and equipment	81
	3.1 Application	
	3.2 Steel grades	
	3.3 Condition of supply	
	3.4 Chemical composition	
	3.5 Mechanical properties	
	3.6 Mechanical tests	
	3.7 Non-destructive examination	
4	Forgings for crankshafts	82
	4.1 Application	
	4.2 Steel grades	
	4.3 Manufacture	
	4.4 Condition of supply	
	4.5 Chemical and mechanical properties	
	4.6 Mechanical tests	
	4.7 Non-destructive examination	
5	Forgings for gearing	83
	5.1 Application	
	5.2 Steel grades	
	5.3 Manufacture	
	5.4 Condition of supply	
	5.5 Chemical and mechanical properties	
	5.6 Mechanical tests for normalised and tempered or quenched and tempered forgings	
	5.7 Mechanical tests for surface-hardened forgings	
	5.8 Non-destructive examination	

6	Forgings for turbines	86
6.1	Application	
6.2	Steel grades, chemical composition and mechanical properties	
6.3	Condition of supply	
6.4	Mechanical tests	
6.5	Non-destructive examination	
6.6	Thermal stability test	
7	Forgings for boilers, pressure vessels and systems	88
7.1	Application	
7.2	Steel grades	
7.3	Condition of supply	
7.4	Chemical composition	
7.5	Mechanical properties	
7.6	Mechanical properties at elevated temperature	
7.7	Mechanical tests	
7.8	Non-destructive examination	
8	Ferritic steel forgings for low temperature service	89
8.1	Application	
8.2	Steel grades and relevant properties	
8.3	Condition of supply	
8.4	Mechanical tests	
8.5	Non-destructive examination	
9	Stainless steel forgings	89
9.1	Application	
9.2	Steel grades and relevant properties	
9.3	Mechanical tests	
9.4	Non-destructive examination	
9.5	Corrosion tests	

Section 4 Steel Castings

1	General	94
1.1	Application	
1.2	Classification of castings	
1.3	Manufacture	
1.4	Approval	
1.5	Quality of materials	
1.6	Visual and dimensional examination	
1.7	Non-destructive examination	
1.8	Rectification of defects	
1.9	Condition of supply - heat treatment	
1.10	Pressure test	
1.11	Sampling and testing	
1.12	Identification and marking	
1.13	Documentation and certification	

2	Casting for hull and other welded structures in general	98
2.1	Application	
2.2	Steel grades	
2.3	Condition of supply	
2.4	Chemical composition	
2.5	Mechanical properties	
2.6	Mechanical tests	
2.7	Non-destructive examination	
3	Castings for machinery and equipment	99
3.1	Application	
3.2	Steel grades	
3.3	Condition of supply	
3.4	Chemical composition	
3.5	Mechanical properties	
3.6	Mechanical tests	
3.7	Non-destructive examination	
4	Castings for crankshafts	100
4.1	Application	
4.2	Steel grades	
4.3	Manufacture	
4.4	Condition of supply	
4.5	Chemical and mechanical properties	
4.6	Mechanical tests	
4.7	Non-destructive examinations and rectification of defects	
5	Castings for boilers, pressure vessels and systems	100
5.1	Application	
5.2	Steel grades	
5.3	Condition of supply	
5.4	Chemical composition and mechanical properties	
5.5	Mechanical properties at elevated temperature	
5.6	Mechanical tests	
5.7	Non-destructive examination	
6	Ferritic steel castings for low temperature service	102
6.1	Application	
6.2	Steel grades	
6.3	Condition of supply	
6.4	Chemical composition and mechanical properties	
6.5	Mechanical tests	
6.6	Non-destructive examination	
7	Stainless steel castings	103
7.1	Application	
7.2	Steel grades and relevant properties	
7.3	Mechanical tests	
7.4	Non-destructive examination	
7.5	Corrosion tests	

Section 5 Iron Castings

1	General	105
	1.1 Application	
	1.2 Casting designation	
	1.3 Manufacture	
	1.4 Quality of castings	
	1.5 Visual, dimensional and non-destructive examination	
	1.6 Repair of defects	
	1.7 Chemical composition	
	1.8 Condition of supply	
	1.9 Sampling and testing	
	1.10 Identification and marking	
	1.11 Documentation and certification	
2	Grey iron castings	106
	2.1 Application	
	2.2 Test material	
	2.3 Mechanical properties	
3	Spheroidal or nodular graphite iron castings	107
	3.1 Application	
	3.2 Manufacture and condition of supply	
	3.3 Test material	
	3.4 Test and mechanical properties	
	3.5 Metallographic examination	
	3.6 Non-destructive examination	

CHAPTER 3

NON FERROUS METAL

Section 1 Copper and Copper Alloys

1	General	113
	1.1 Application	
	1.2 Manufacture	
	1.3 Testing	
	1.4 Documentation and certification	
2	Copper alloy castings	113
	2.1 Application	
	2.2 Manufacture	
	2.3 Condition of supply	
	2.4 Chemical composition	
	2.5 Mechanical properties	
	2.6 Mechanical tests	
	2.7 Visual and non-destructive examination	
	2.8 Rectification of defective castings	
	2.9 Identification and marking	
3	Copper alloy pipes	115
	3.1 Application	
	3.2 Condition of supply	
	3.3 Chemical composition	
	3.4 Mechanical properties	
	3.5 Mechanical tests	
	3.6 Stress corrosion cracking test	
	3.7 Hydrostatic test - Eddy current test	
	3.8 Visual and non-destructive examination	
	3.9 Rectification of defects	
	3.10 Identification and marking	

Section 2 Aluminium Alloys

1	General	118
	1.1 Application	
	1.2 Manufacture	
2	Wrought aluminium alloy products (plates, bars, sections and tubes)	118
	2.1 Application	
	2.2 Aluminium grades	
	2.3 Manufacture	
	2.4 Chemical composition	
	2.5 Corrosion testing	
	2.6 Mechanical properties	
	2.7 Mechanical tests	
	2.8 Testing	
	2.9 Re-test procedures	
	2.10 Hydrostatic test	
	2.11 Visual and non-destructive examination	
3	Rivets	124
	3.1 Application	
	3.2 Chemical composition and heat treatment	
	3.3 Heat treatment	
	3.4 Test material	
	3.5 Mechanical tests	
	3.6 Identification	
	3.7 Certification	
4	Transition joints	125
	4.1 General	
	4.2 Manufacture	
	4.3 Visual and non-destructive examination	
	4.4 Inspection	
5	Aluminium alloy castings	126
	5.1 General	
	5.2 Aluminium grades	
	5.3 Manufacture	
	5.4 Chemical composition	
	5.5 Mechanical properties	
	5.6 Mechanical tests	

CHAPTER 4

MISCELLANEOUS EQUIPMENT

Section 1 Equipment

1	Anchors and associated equipment	131
---	----------------------------------	-----

1.1

Section 2 Various Finished Products

1	Cast copper alloy propellers and propellers blades	132
---	--	-----

- 1.1 Application
- 1.2 Manufacture
- 1.3 Quality of castings
- 1.4 Condition of supply
- 1.5 Chemical composition
- 1.6 Mechanical properties
- 1.7 Sampling and testing
- 1.8 Visual and dimensional examination
- 1.9 Inspection - Severity zones
Non-destructive examinations
- 1.10 Dye penetrant examination
- 1.11 Radiographic and ultrasonic examination
- 1.12 Repair procedures
- 1.13 Straightening
- 1.14 Identification and marking

2	Pressure bottles	138
---	------------------	-----

- 2.1 Application
- 2.2 Manufacture
- 2.3 Inspection and tests
- 2.4 Identification, marking and certification

3	Cast steel propellers and propeller blades	140
---	--	-----

- 3.1 Application
- 3.2 Manufacture
- 3.3 Quality of castings
- 3.4 Condition of supply
- 3.5 Chemical composition
- 3.6 Mechanical properties
- 3.7 Sampling
- 3.8 Visual and dimensional examination
- 3.9 Non-destructive examinations - Severity Zones
- 3.10 Repair procedures
- 3.11 Identification
- 3.12 Certification

CHAPTER 5 WELDING

Section 1 General Requirements

1	Application	147
	1.1 General	
2	Fabrication by welding	147
	2.1 General	
	2.2 Approval	
	2.3 Welding procedures	
	2.4 Type of joints, edge preparations and size	
	2.5 Welding execution and control	

Section 2 Approval of Welding Consumables

1	General	149
	1.1 Application	
	1.2 Grading and designation	
	1.3 Approval procedure	
	1.4 Preparation and welding of test assemblies	
	1.5 Mechanical tests	
	1.6 Test samples for checking the chemical composition of deposited weld metal	
	1.7 Re-test procedures	
2	Covered electrodes for manual metal arc welding of C and C-Mn steels	153
	2.1 Application	
	2.2 Approval tests	
	2.3 Tests for checking the operating characteristics	
	2.4 Tests for checking the mechanical properties	
	2.5 Tests for checking the hydrogen content	
	2.6 Fillet weld test assemblies	
	2.7 Annual control tests	
3	Covered electrodes for gravity or contact welding	160
	3.1 Application	
	3.2 Approval tests	
	3.3 Annual control tests	
4	Covered electrodes for deep penetration manual welding of C and C-Mn steels	160
	4.1 Application	
	4.2 Approval tests	
	4.3 Annual control tests	
5	Flux-wire combination for submerged arc welding of C and C-Mn steels	162
	5.1 Application	
	5.2 Approval tests	
	5.3 Annual control tests	

6	Flux-wire combinations for one side submerged arc welding of butt-joints of C and C-Mn steels	167
	6.1 Application	
	6.2 Approval tests	
	6.3 Annual control tests	
7	Wires and wire-gas combination for semiautomatic welding of C and C-Mn steels	167
	7.1 Application	
	7.2 Type of wires	
	7.3 Shielding gases	
	7.4 Grading	
	7.5 Information and documentation to be submitted	
	7.6 Approval tests	
	7.7 Annual control tests	
8	Wires and wire-gas combinations for automatic welding of C and C-Mn steels	171
	8.1 Application	
	8.2 Approval tests	
	8.3 Annual control tests	
9	Consumables for welding C and C-Mn steels with electrogas or electroslag process	173
	9.1 Application	
	9.2 Information and documentation to be submitted	
	9.3 Approval tests	
	9.4 Annual control tests	
10	Consumables for welding high strength quenched and tempered steels	175
	10.1 Application	
	10.2 Approval tests	
	10.3 Test requirements	
	10.4 Annual control tests	
11	Consumables for welding Mo and Cr-Mo steels	177
	11.1 Application	
	11.2 Approval tests	
	11.3 Test requirements	
	11.4 Periodical control tests	
12	Consumables for welding Ni steels for low temperature applications	178
	12.1 Application	
	12.2 Approval tests	
	12.3 Tests requirements	
	12.4 Annual control tests	
13	Consumables for welding Cr-Ni austenitic and austenitic-ferritic stainless steels	179
	13.1 Application	
	13.2 Approval tests	
	13.3 Test requirements	
	13.4 Annual control tests	

14	Consumables for welding aluminium alloys	181
	14.1 Application	
	14.2 Approval tests	
	14.3 Test requirements	
	14.4 Annual control tests	

Section 3 Approval of Over Weldable Shop Primers

1	Application	185
	1.1 General	
2	Information and documentation to be submitted	185
	2.1 General	
3	Approval tests	185
	3.1 General	
	3.2 Base material	
	3.3 Filler metal	
	3.4 Type and dimension of test samples	
	3.5 Number of samples required	
	3.6 Operational procedures	
	3.7 Test requirements	
	3.8 Re-tests	
4	Certification	186
	4.1	
5	Periodical control tests	186
	5.1	

Section 4 Approval of Welding Procedures

1	General	187
1.1	Application	
1.2	Welding procedure	
2	Welding procedures for C and C-Mn steels	188
2.1	Butt weld on plates	
2.2	T butt-joint on plates	
2.3	T fillet joint	
2.4	Butt weld on pipes	
2.5	Re-testing	
2.6	Range of approval	
3	Welding procedures for Cr-Ni austenitic and austenitic-ferritic stainless steels for application with chemicals	198
3.1	General	
4	Approval of welding procedures for high strength quenched and tempered steels	198
4.1	General	
5	Approval of welding procedures for forgings and castings	198
5.1	General	
6	Approval of welding procedures for aluminium alloys	198
6.1	Butt weld on plates	
6.2	T fillet joint	
6.3	Range of approval	
7	Approval of welding procedures for repair of propellers	201
7.1	General	
7.2	Assembly and welding	
7.3	Examination and tests	
7.4	Additional test for cast steel propellers	

Section 5 Approval of CO₂ Laser Welding Procedures

1	General	204
	1.1 Application	
	1.2 General requirements	
	1.3 Welding personnel	
	1.4 Welding procedure specification	
	1.5 Parent metal	
	1.6 Welding consumables	
2	Welding procedure	205
	2.1 General	
	2.2 Assembly and welding	
3	Non-destructive examinations	205
	3.1 General	
	3.2 Visual examination	
	3.3 Radiographic examination	
	3.4 Ultrasonic examination	
	3.5 Magnetic particle	
4	Butt weld procedure test	205
	4.1 Assembly	
	4.2 Examinations and tests	
	4.3 Tensile tests	
	4.4 Bend tests	
	4.5 Impact tests	
	4.6 Hardness measurements	
	4.7 Metallographic examination	
5	Fillet weld procedure test	208
	5.1 Assembly	
	5.2 Examinations and tests	
6	Re-testing	209
	6.1 Non-destructive examinations	
	6.2 Destructive tests	
7	Range of approval	209
	7.1 Parent metal	
	7.2 Thickness	
	7.3 Edge preparation and surface condition	
	7.4 Joint type, bevel	
	7.5 Welding procedure	
	7.6 Welding parameters	

Part D
Materials and Welding

Chapter 1
GENERAL REQUIREMENTS

SECTION 1 MANUFACTURE, INSPECTION, CERTIFICATION

SECTION 2 TESTING PROCEDURES FOR MATERIALS

SECTION 1

MANUFACTURE, INSPECTION, CERTIFICATION

1 General

1.1 Application

1.1.1 Part D specifies in Chapter 2 to Chapter 4 the requirements for the manufacture, inspection and certification of steel and iron products, non-ferrous metals, various finished products and equipment such as propellers, pressure bottles, anchors, chain cables, ropes and sidescuttles, entering in the construction or repair of ships which are surveyed for classification purposes.

The general requirements relevant to the manufacture, inspection and certification of the above-mentioned materials and products, hereafter generally referred to as "products", are given in this Chapter and are to be complied with as applicable.

The requirements of Chapter 1 are also applicable, as appropriate, to products covered by other parts of the Rules.

Part D specifies in Chapter 5 the requirements for approval of welding consumables and qualification of welding procedures.

1.1.2 In addition to Part D, the requirements given for certain materials, procedures and products in the other Parts of the Rules or specified on the approved plans, are also applicable, where appropriate.

1.1.3 Products subject to the requirements of Part D and the relevant testing operations are those laid down in the relevant Rules of ^{Tasneef} dealing with the design, inspection at works and testing of products, unless otherwise specified.

1.1.4 Products with properties departing appreciably from those covered by the Rules may be used with the approval of ^{Tasneef}

1.2 Other specifications

1.2.1 Products complying with international, national or proprietary specifications may be accepted by ^{Tasneef} provided such specifications give reasonable equivalence to the requirements of these Rules or are approved for a specific application.

Such products, when accepted, are designated by their standard identification mark or as agreed at the time of the approval.

Unless otherwise agreed, inspection and certification of products complying with other specifications are to be carried out in accordance with the requirements of the Rules.

1.3 Information to be supplied by the purchaser

1.3.1 The purchaser is to provide the Manufacturer with the information necessary to ensure that products are tested in accordance with these Rules; optional or additional conditions are also to be clearly indicated.

2 Manufacture and quality

2.1 General

2.1.1 Manufacture

Manufacturers and their individual works are to be recognised by ^{Tasneef} for the type of products fabricated.

To this end plants, production and treatment procedures, testing machines, laboratories for analyses, internal control systems and personnel qualification are to be suitable in the opinion of ^{Tasneef}

Manufacturing procedures and techniques are to be such as to reasonably ensure constant compliance of the product with the requirements.

Where tests and analyses are performed by external laboratories or third parties, these are to be recognised by ^{Tasneef}

2.1.2 Approval

Depending on the type and importance of the products being supplied, the relevant manufacturing process may be required to be approved and approval tests performed for the purpose.

When approval of the manufacturing process is required, such condition is specified in the rule requirements relevant to the various products.

The provisions for the approval of Manufacturers are given in the "Rules for the approval of Manufacturers of materials".

2.1.3 Responsibility

Irrespective of the interventions of Surveyors, the Manufacturer is entirely and solely responsible for compliance of the supplied products with the stipulated requirements.

^{Tasneef} assumes no liability by its testing interventions in respect of the compliance of a tested product with the stipulated regulations and requirements.

Where, in the course of manufacture or after supply, a product is found not to be in compliance with the requirements or to present unacceptable defects, it will be rejected, irrespective of any previous satisfactory test results.

2.2 Chemical composition

2.2.1 The chemical composition is to be determined and certified, as a rule, by the Manufacturer using ladle sam-

pling analysis. The laboratory is to be adequately equipped and the analyses are to be performed by qualified personnel.

2.2.2 The analyses of the Manufacturer are generally accepted subject to occasional checks, if required by the Surveyor. When checks on the product are required, they are to be performed and the results evaluated in accordance with recognised standards.

2.3 Condition of supply

2.3.1 Unless otherwise agreed, the products are to be supplied in the finished condition as per rules, including heat treatment if required.

Heat treatment is to be carried out in suitable and efficient furnaces, fitted with appropriate means for temperature control and recording.

The furnaces employed are to have a size sufficient to allow a uniform increase in temperature up to the required value of the whole furnace charge to be heat treated. In the case of very large parts, alternative systems proposed are to be agreed by ^{Tasneef}

Sufficient thermocouples are to be connected to the furnace charge to measure and record its temperature and check that it is adequately uniform, unless the temperature uniformity of the furnace is verified at regular intervals.

2.4 Identification of products

2.4.1 In the course of manufacturing, inspection and testing, the identification of the various products in respect of their origin is to be ensured as required.

To this end the Surveyor is to be given all facilities for tracing the products when required.

3 Inspection and testing

3.1 General conditions

3.1.1 As a rule, the inspections and tests are to be carried out at the Manufacturer's works before delivery.

If the necessary facilities are not available at the Manufacturer's works, the testing is to be carried out at a recognised testing laboratory.

3.1.2 Where the testing is allowed to be carried out or completed at works other than the Manufacturer's it is in any case to be possible to trace back with certainty to the documentation of the origin.

3.1.3 Interested parties are to apply for inspection in adequate time.

Prior to the inspection and testing, the Manufacturer is to provide the Surveyor with details of the orders, technical

specifications and any special condition additional to the rule requirements.

3.1.4 The Surveyors are to have free access to all departments involved in production, collection of test samples, internal control and, in general, all operations concerning the inspection.

They are to be supplied with the information necessary to assess whether production and tests are performed according to the rule requirements.

3.1.5 All tests and checks required by the Rules are to be carried out in the presence of the Surveyors or, when expressly agreed with ^{Tasneef} in the presence of the person responsible for internal control, specially delegated for this purpose.

The inspection and testing activities may be delegated to the Manufacturer under the conditions given in [3.2].

3.1.6 The tests required are to be performed by qualified personnel in accordance with the procedures stated by ^{Tasneef} or, failing this, with recognised national or international standards.

The testing and measuring equipment is to be adequate, maintained in proper condition and regularly calibrated, as required; the record of such checks is to be kept up-to-date and made available to the Surveyor.

3.2 Alternative inspection scheme

3.2.1 Alternative procedures to the systematic intervention of the Surveyor for testing may be adopted by Manufacturers specially recognised by ^{Tasneef} for the purpose.

Such alternative inspection schemes, which are determined by taking into account the type of product, its mass production and the effectiveness of the certified Quality System implemented in the workshop, allow the testing operations indicated in these Rules to be totally or partially delegated to the Manufacturer.

Indications on the field of application of such schemes, along with conditions and procedures for their recognition, are given by ^{Tasneef} in a separate document.

3.3 Sampling for mechanical tests

3.3.1 The test samples are to be selected by the Surveyor or by a responsible person from the Manufacturer's staff, specially delegated, and are to be suitably marked for identification purposes.

3.3.2 The test samples are to be representative of the unit or lot of material which they are relevant to and are therefore also to have been subjected to the same heat treatment as the products except when a different procedure is agreed with ^{Tasneef}

3.3.3 For the purpose of test sampling the following definitions apply:

- a) unit: single forging, casting, plate, tube or other single product
- b) rolled unit: product rolled from the same slab or billet or, when rolling proceeds directly from ingots, from the same ingot
- c) batch: number of similar units or rolled units presented as a group for acceptance testing, on the basis of the tests to be carried out on the test sample
- d) sample: a sufficient quantity of material taken from the unit, rolled unit or batch, for the purpose of producing one or more test specimens
- e) test specimens: part of sample with specified dimensions and conditions for submission to a given test.

3.4 Mechanical tests

3.4.1 The mechanical tests are to be carried out in the presence of the Surveyor unless otherwise agreed; see [3.2].

3.4.2 For the check of the mechanical properties of the material, test methods and specimens in compliance with the requirements of Sec 2 are to be used.

3.4.3 The type of tests, the number and direction of the test specimens and the results of the tests are to comply with the requirements relevant to the type of product, as indicated in the various Articles.

3.5 Re-test procedures

3.5.1 General

Where the unsuccessful outcome of any test is attributable to defective machining of the test specimen and/or to improper test procedure, the negative result is disregarded and the test repeated, in correct conditions, on a substitute test specimen.

Where a test, other than an impact test, gives a result which is not in compliance with the requirements, two additional tests may be allowed to be performed on specimens of the same type taken from the same samples. For the purpose of acceptance, both tests are to comply with the requirements.

For the impact test, performed on a set of three test specimens, where the average value of the set does not comply with the required value, provided that not more than two test results are less than such value, with not more than one less than 70% of it, a second test may be allowed to be performed on three test specimens of the same type taken from the same samples.

For acceptance, the new average, calculated on the basis of the six results of the first and second sets of three test specimens taken together, is to comply with the required value, not more than two individual values are to be lower than the required average and, of these, not more than one is to be less than 70% of it.

3.5.2 Rejection or reconsideration

Where unsatisfactory results are obtained from re-tests representative of one lot of material, the unit from which the test specimens are taken is rejected.

The remainder of the lot may, at the discretion of the Surveyor, be reconsidered by performing the required tests on at least two different units; for acceptance, both the results of the new tests are to satisfy the requirements.

Otherwise, upon agreement with the Surveyor, the individual units composing the lot may be tested individually and those found satisfactory may be accepted.

The Manufacturer may resubmit for testing previously rejected material, after a suitable heat treatment or reheat treatment, or resubmit it under a different grade.

The Surveyor is to be notified of such circumstances.

Unless otherwise agreed by the Surveyor, only one new heat treatment is permitted for material which has already been heat treated.

3.6 Visual and dimensional examinations and non-destructive tests

3.6.1 General

The products are to be subjected to:

- a) visual examination
- b) dimensional check
- c) non-destructive examination, when applicable.

The above operations, to be effected on products in appropriate conditions, are carried out under the responsibility of the Manufacturer and are to be witnessed or repeated in the presence of the Surveyor when required by the Rules or, in any case, when it is deemed necessary by the Surveyor.

When, following examinations and tests, there are grounds for thinking a product may be defective, the Manufacturer is obliged, for the purpose of acceptance, to demonstrate its suitability using procedures deemed necessary.

3.6.2 Visual examination

Visual examination, unless otherwise specified, is performed by the Surveyor on each unit, for products tested on individual units and, randomly or on the units submitted to mechanical tests, for products tested by lot.

3.6.3 Dimensional check

The dimensional checks and verification of compliance with approved plans are carried out by the Surveyor, as deemed necessary, solely for those parts subject to approval, or where expressly required in Part D or other parts of the Rules.

3.6.4 Non-destructive test

Non-destructive test is to be performed by operators qualified according to a national recognised scheme with a grade equivalent to level II qualification of ISO 9712, SNT-TC-1A, EN 473 or ASNT Central Certification Program (ACCP). Operators qualified to level I may be engaged in the tests under the supervision of personnel qualified to level II or III. Non-destructive test is to be performed using calibrated equipment of suitable type and according to approved procedures, recognised standards and the requirements of Tasneef Personnel responsible for the preparation and approval of NDT procedures are to be qualified to a grade equivalent to level III of ISO 9712, SNT-TC-1A, EN 473, ACCP or ASNT.

The Manufacturer's laboratory or other organisation responsible for the non-destructive test is required to issue, on its own responsibility, a certificate illustrating the results and, where requested, an opinion concerning the acceptability of the product; in the latter case, the certificate is to be countersigned by the Manufacturer.

Personnel qualifications are to be verified by certification. Personnel certificates are to be issued by Tasneef by another IACS Society or by a recognised third party body.

For the radiographic test suitable means are to be provided in order to identify the zones examined and the relevant radiographic films.

The various steps of the examinations are to be witnessed by the Surveyor when required. In such case the certificates are generally to be countersigned by the witnessing Surveyor.

The radiographic examination is intended to be carried out by using X-ray. The use of gamma-ray may be accepted provided that it is demonstrated to Tasneef satisfaction that this provides the same image quality as X-ray.

3.7 Repairs of defects

3.7.1 Small surface defects may be suitably removed by grinding or other appropriate means, provided that the dimensional tolerances, prescribed for the various products in the relevant Articles, are complied with.

The repaired zone is to be found free from defects and to be acceptable in the opinion of the Surveyor.

3.7.2 Repairs by welding may be accepted only where this is not in contrast with the requirements applicable to the product, and provided that they are deemed suitable in connection with the material, extent of defects and welding procedure.

The repair procedure is to be previously agreed upon with the Surveyor.

4 Identification and certification

4.1 Identification and marking

4.1.1 General

During the inspection, a detailed record of the products to be tested is to be submitted to the Surveyor with indication of the necessary data, as applicable:

- a) name of purchaser and order number
- b) hull number or destination
- c) number, size and mass of parts or batches
- d) cast number and chemical composition
- e) part reference number, detail of manufacturing process and heat treatment
- f) condition of supply.

4.1.2 Manufacturer's marking

Products, which have satisfactorily undergone the required inspection and tests are to be appropriately marked by the Manufacturer in at least one easily accessible location.

The marking is to contain all necessary indications, as specified in the Articles relevant to the various products, and is to correspond to the content of the inspection documentation.

The marks are to be stamped, as a rule, by means of brands, except when products could be impaired by such a system. When paints or other reliable alternatives are adopted, adequate duration of marking is to be ensured.

For small pieces contained in effective containers, as well as bars and sections of modest weight, adequately bound in bundles, the marks are transferred to the container, label or top item of each bundle to the Surveyor's satisfaction.

4.1.3 Marking with Tasneef brand

The products satisfactorily inspected in accordance with the Rules are to be marked with Tasneef brand in the presence of the Surveyor unless otherwise agreed between Manufacturer and Surveyor.

All other additional marks required are specified in the applicable Articles depending on the products (e.g. name or initials of Manufacturer, material, grade and cast number, code for calendar year, running file number and code of the local office inspection, Surveyor's personal brand, TP as statement of hydrostatic test).

4.1.4 Society marking for incomplete inspection

Whenever a product is despatched for delivery or is to be marked without undergoing all the inspections and tests required (whether by the provisions of Part D or those of other parts of the Rules), Tasneef brand will be replaced by Tasneef mark for incomplete inspection.

The testing documents are to contain clear indications of all outstanding inspections and tests and specify the reason why they have not been performed.

Upon satisfactory completion of all required tests, the product is to be stamped with Tasneef brand.

4.1.5 Invalidation of Society's brand

When a product already marked with one of Tasneef stamps is found during or subsequent to the testing not to be in compliance with the requirements and is therefore rejected, the previously stamped marks are to be invalidated by punching them.

The Surveyors may request to check the invalidation effected.

Any repairs after the product is tested are subject to the prior consent of Tasneef failing this, the validity of the original testing will automatically expire and the original testing marks are to be invalidated by the interested parties.

4.1.6 Society's brand for alternative inspection scheme

In the case of admission to an alternative inspection scheme, the marking with Tasneef brand may be delegated to the Manufacturer, who will be supplied with the special brand to be used for this purpose.

4.2 Documentation and certification

4.2.1 Society's inspection certificate

For products tested with satisfactory results, ^{Tasneef} issues an inspection certificate signed by the Surveyor stating that the products have been tested in accordance with ^{Tasneef} Rules.

This certificate is identified by the letter C for ease of reference in the various parts of the Rules.

An inspection certificate issued by the Manufacturer is to be attached to ^{Tasneef} certificate and is to include, as applicable, the following particulars:

- a) Manufacturer's name
- b) purchaser's name, order number and hull number
- c) description of the product, dimensions and weight
- d) results of all specified inspections and tests, including non - destructive tests where applicable
- e) identification and testing marks stamped on the products.

In the case of testing of materials, the following particulars are also to be included:

- identification of specification or grade of material
- identification of the heat and relevant chemical analysis
- supply condition and the specification of heat treatment, if carried out, including temperature and holding time
- working and manufacturing procedure (for rolled products intended for hull, boilers and pressure vessels only)
- declaration that the material has been made by an approved process, as applicable, and that it has been subjected with satisfactory results to the tests required by the Rules.

By agreement with ^{Tasneef} the inspection certificate issued by the Manufacturer may be directly confirmed by endorsement with ^{Tasneef} brand and the signature of the Surveyor.

For products manufactured in large quantities and tested by heats or by lot, the Manufacturer is to further state, for the

individual supplies, that the products have been produced according to ^{Tasneef} Rules.

4.2.2 Society's inspection certificate for alternative inspection scheme

For products covered by the alternative inspection scheme, unless otherwise stated in the admission to the alternative inspection scheme, the Manufacturer is to issue a Certificate of Conformity on the appropriate Society form.

This certificate is identified by the letter CA (certificate for alternative survey) for ease of reference in the various parts of the Rules.

The inspection certificate issued by the Manufacturer and including all the information required in [4.2.1] is to be attached to the (CA) certificate.

The certificate is to be submitted to ^{Tasneef} for endorsement according to the procedures stated in the agreement for the alternative survey scheme.

4.2.3 Works' certificates

For products which in accordance with the relevant rules may be accepted only on the basis of a certificate of conformity issued by the Manufacturer, stating the results of the tests performed, such certificate is to contain the information required under [4.2.1], as applicable.

This certificate of conformity is identified by the letter W (works' certificate) for ease of reference in the various parts of the Rules.

For particular products it may be accepted that the tests or inspections are carried out by the Manufacturer not on the product supplied, but on the current production.

This particular certificate of conformity is identified by the letter R (report) for ease of reference in the various parts of the Rules.

SECTION 2

TESTING PROCEDURES FOR MATERIALS

1 General

1.1 Application

1.1.1 This Section specifies the requirements for testing procedures, testing machines and test specimens for mechanical and technological tests of materials.

The testing procedures and test specimens relevant to welding are specified in Chapter 5.

The Articles of the Rules, dealing with the various products, indicate the examinations and tests required together with the results to be obtained.

The general conditions specified in Sec 1 also apply.

1.2 Testing machines

1.2.1 Testing machines are to be maintained in a satisfactory and accurate condition and calibrated by Tasneef or by a recognised body in accordance with a recognised standard, at approximately annual intervals.

In particular:

- The accuracy of tensile test machines is to be within $\pm 1\%$ and when the calibration is in accordance with ISO 7500-1 the permitted indication errors are to be within the specific values for Class 1.
- Impact testing machines are to be calibrated in accordance with ISO 148-2 or other recognised standard.

The striking energy of the testing machine is to be not less than 150 J.

The records of the calibration are to be made available to the Surveyor and kept in the test laboratory.

1.3 Preparation of test specimens

1.3.1 The samples for test specimens are to be in the same condition as the product from which they have been taken and therefore in the same heat treatment condition, if any.

1.3.2 If the test samples are cut from products by flame cut, when admissible depending on the kind of material, or shearing, a reasonable margin is required to enable sufficient material to be removed from cut or sheared edges during final machining.

Test specimens are to be obtained from samples by mechanical cuts; care should be taken in their preparation to avoid any significant straining or heating which might alter the properties of the material.

2 Tensile test

2.1 Test specimens

2.1.1 Proportional flat specimen

For flat products, rectangular specimens of proportional type are generally used, having dimensions as shown in Fig 1.

Figure 1 : Proportional flat specimen

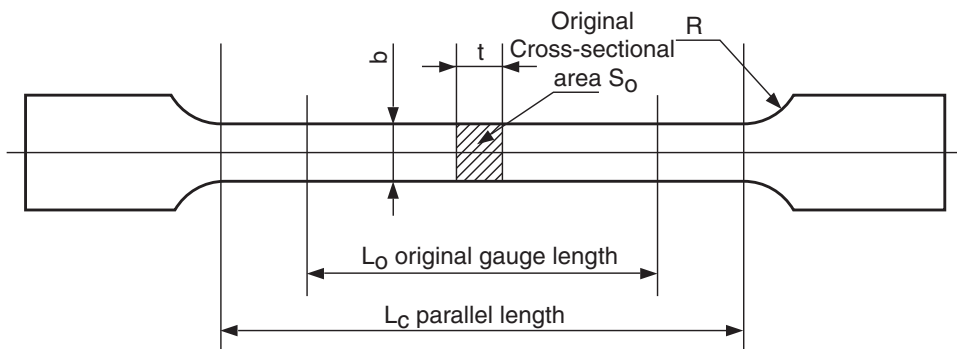

t : thickness of the considered material

b : 25 mm (width)

L₀ : $5,65S_0^{1/2}$ where S₀ is the specimen original cross sectional area. The gauge length may be rounded off the nearest 5 mm provided that the difference between the computed L₀ and that rounded length is less than 10% of L₀.

L_c : $L_0 + 2S_0^{1/2}$

R : 25 mm (transition radius)

For such products the tensile test specimens are to retain the original raw surfaces of the product.

When the testing machine capacity does not allow testing of specimens of full thickness, this may be reduced by machining one of the raw surfaces.

2.1.2 Non-proportional flat specimen

As an alternative to the specimen mentioned above, non-proportional specimens may also be used; in particular a rectangular specimen, having fixed gauge length of 200 mm and other dimensions as shown in Fig 2, may be used.

2.1.3 Round specimen

As stated in [2.1.1], for rolled products, excluding bars, the tensile test specimens are to retain the original raw surfaces of the product.

However, for thickness equal to or greater than 40 mm, or, more generally, when the testing machine capacity does not allow testing of specimens of full thickness, a round proportional test specimen, machined to the dimensions shown in Fig 3, may also be used.

For long rolled products (bars and profiles), forgings and castings, grey cast iron excluded, cylindrical specimens of proportional type, having in general diameter of 10 or 14 mm, are to be used.

2.1.4 Round specimen diameter

The proportional round tensile specimens generally have diameter of 10 or 14 mm.

However others diameters, in general 8 or 6 mm, may be used in specific cases when the selection of normal size test specimens is not possible.

2.1.5 Round specimen position

In the case of rolled products (plates), with thickness equal to or greater than 40 mm, the axis of the round test specimen is to be located at approximately one quarter of the thickness from one of the rolled surfaces.

In the case of bars and similar products, the axis of the round test specimen is to be located at one third of the radius from the outside.

In the case of forged products, unless otherwise agreed, the longitudinal axis of test specimens is to be positioned as follows:

- for thickness or diameter up to maximum 50mm, the axis is to be at the mid-thickness or the centre of the cross section;
- for thickness or diameter greater than 50mm, the axis is to be at one quarter thickness (mid-radius) or 80mm, whichever is less, below any heat treated surface.

Figure 2 : Non proportional flat specimen

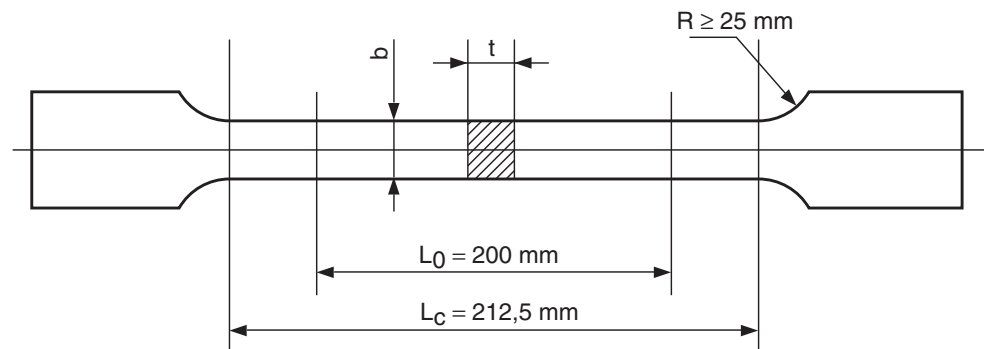

- t : thickness of the considered flat material
b : 25 mm

Figure 3 : Round proportional specimen

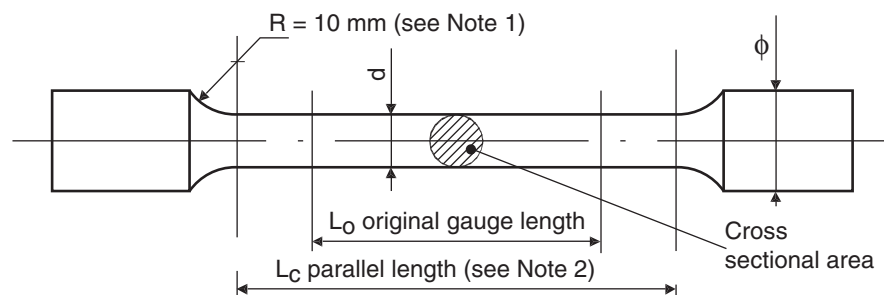

Note 1: $R \geq 1,5 d$ for nodular cast iron and materials with a specified elongation less than 10%

Note 2: $L_c = L_0 + d/2$

2.1.6 Specimen for grey cast iron

For grey cast iron, the test specimen as shown in Fig 4 is to be used.

Figure 4 : Specimen for grey cast iron

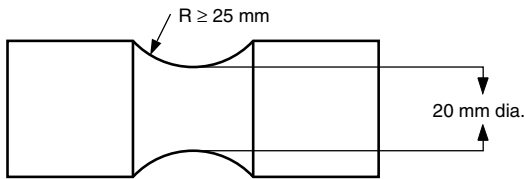

2.1.7 Specimens for pipes and tubes

For testing of pipes and tubes, the testing specimen may be a full cross-section of suitable length to be secured in the testing machine with plugged ends, as shown in Fig 5.

The gauge length L_0 is to be equal to:

$$L_0 = 5,65 \sqrt{S_0}$$

and the distance between the grips or between the plugs L_c is to be not less than the gauge length plus $D/2$, where D is the external diameter of the tube or pipe.

The length of the plugs projecting over the grips, in the direction of the gauge marks, is not to exceed the external diameter D , and the shape of the plugs is not to impede the elongation of the gauge length.

Figure 5 : Full cross section specimen

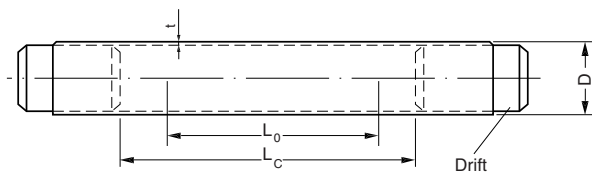

Alternatively test specimens are to be taken from the tube or pipe wall, as shown in Fig 6, where:

$$L_0 = 5,65 \sqrt{S_0}$$

$$L_c = L_0 + 2 b$$

Figure 6 : Specimen taken from the tube or pipe wall

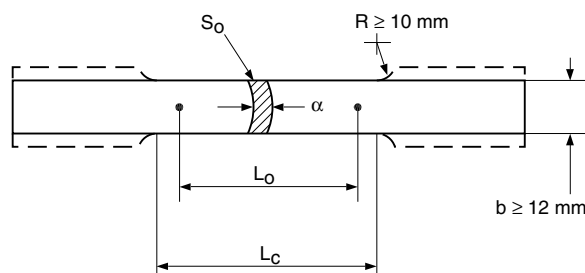

Where the wall thickness is sufficient to allow machining, the round specimen indicated in Fig 3 may be used, with the axis located at the mid-wall thickness.

2.1.8 Specimen for wires

For testing of wires, a full cross-section test specimen of suitable length is to be used.

The gauge length is to be 200 mm and the parallel test length (distance between the grips) is to be 250 mm.

2.1.9 Dimensional tolerances

The dimensional tolerances of test specimens are to be in accordance with ISO 6892-84 or other recognised standards as appropriate.

2.2 Testing procedure

2.2.1 General

The following characteristics, as required by the different products, are to be determined by the test:

- a) R_{eH} : Yield stress (yield point), in N/mm^2
- b) $R_{p0,2} - R_{p1,0}$: Proof stress (yield strength), in N/mm^2
- c) R_m : Tensile strength, in N/mm^2
- d) A: Percentage elongation at fracture
- e) Z: Percentage reduction of area.

2.2.2 Yield and proof stress determination

For materials with well defined yield phenomenon, the yield stress R_{eH} is the value corresponding to the first stop or drop of the index, showing the load applied by the testing machine in the tensile tests at ambient temperature.

This applies, unless otherwise specified, to products of carbon steels, carbon-manganese steels and alloy steels, except austenitic and duplex stainless steels.

For materials which do not present a manifest yield stress, as defined above, the 0,2% proof stress ($R_{p0,2}$) is to be determined according to the applicable specification, where 0,2 is the percentage of permanent deformation.

For austenitic and duplex stainless steel products and relevant welding consumables, the 1,0 per cent proof stress, designated by the symbol $R_{p1,0}$, may be required in addition.

2.2.3 Load application rate

The test is to be carried out with an elastic stress within the limits indicated in Tab 1.

After reaching the yield or proof load, for ductile material the machine speed during the tensile test is not to exceed that corresponding to a strain rate of $0,008s^{-1}$. For brittle materials, such as cast iron, the elastic stress rate is not to exceed $10 N/mm^2$ per second.

Table 1

Modulus of Elasticity of the material (E), in N/mm^2	Rate of stressing, in $N/mm^2 s^{-1}$	
	Min.	Max.
$E < 150000$	2	20
$E \geq 150000$	6	60

2.2.4 Elongation

The per cent elongation is in general determined on a proportional gauge length L_0 .

L_0 is determined by the following formula:

$$L_0 = 5,65 \sqrt{S_0}$$

where:

S_0 : Original cross-sectional area of the test specimen.

In the case of round solid specimens, L_0 is 5 diameters.

The per cent elongation is also defined as short proportional elongation or A_5 .

When a gauge length other than L_0 is used, the equivalent per cent elongation A_x required is obtained from the following formula:

$$A_x : 2A_5 \left(\frac{\sqrt{S}}{L} \right)^{0.4}$$

where:

A_5 : Minimum elongation, in per cent, required by the Rules for the proportional specimens illustrated in Fig 1, Fig 3 and Fig 6

S : Area, in mm^2 , of the original cross-section of the actual test specimen

L : Length, in mm, of the corresponding gauge length actually used.

The above conversion formula may be used only for non-cold formed ferritic products with tensile strength not exceeding 700 N/mm^2 .

The extension of the formula to other applications, such as cold worked steels, austenitic steels or non-ferrous materials is to be agreed upon with Tasneef Surveyors.

In the case of disagreement, the value of elongation computed on the proportional specimen is to be taken.

The gauge length to which the elongation is referred is to be indicated in the test reports.

For non-proportional test specimens with gauge length of 50 mm and 200 mm, the equivalent elongation values indicated in ISO 2566 apply.

The elongation value is, in principle, valid only if the distance between the fracture and the nearest gauge mark is not less than one third of the original gauge length. However, the result is valid irrespective of the location of the fracture if the percentage elongation after fracture is equal to or greater than the expected value.

The appearance of the fracture of test specimens after the tensile test is always to be examined. The appearance of the fracture section is to be sound and free from defects and irregularities.

2.2.5 Testing at elevated temperature

For testing at elevated temperature, the determination of 0,2 per cent proof stress is to have a gauge length for strain measurement not less than 50 mm and a cross-sectional area not less than 65 mm^2 . However, if the dimensions of the product or the available test equipment do not allow such conditions, the largest possible dimension is to be used.

As yield stress the conventional value of 0,2 per cent proof stress is generally taken; the deformation rate immediately prior to reaching the yield stress is to be in the range between 0,1 and 0,3 per cent of the gauge length per minute.

The intervals between deformation measurements to assess the above-mentioned rate are not to exceed 6 seconds.

The equipment is to permit a test temperature control within a tolerance range $\pm 5^\circ\text{C}$.

2.2.6 Re-test procedure

When the tensile test fails to meet the requirements, two further tests may be made from the same piece.

If both of these additional tests are satisfactory, the item and/or batch (as applicable) is acceptable. If either or both of these tests fail, the item and/or batch is to be rejected.

The additional tests detailed above are preferably to be taken from material adjacent to that for the original tests, but alternatively from another test position or sample representative of the item/batch.

3 Bend test

3.1 Flat bend test specimen

3.1.1 A flat bend test specimen as shown in Fig 7 is to be used.

The edges on the tension side are to be rounded to a radius of 1 to 2 mm.

The length of the specimen is to be at least 11 times the thickness or 9 times the thickness plus the mandrel diameter, if this value is higher.

Figure 7 : Flat bend specimen

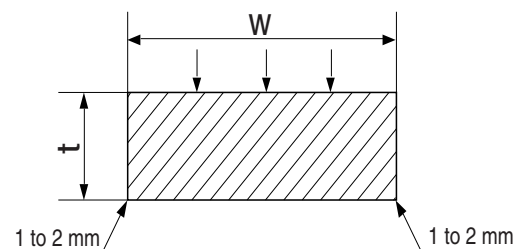

3.1.2 For castings, forgings, and half rough products, the other dimensions are to be as follows:

thickness: $t = 20 \text{ mm}$,

width: $w = 25 \text{ mm}$.

3.1.3 For rolled products the other dimensions are to be as follows:

thickness: $t = \text{thickness of product}$,

width: $w = 30 \text{ mm}$.

If the thickness of the rolled product is greater than 25 mm, the thickness of the specimen may be reduced to 25 mm by machining the surface of the specimen that is to be in compression during the test.

3.2 Testing procedure

3.2.1 The bend test is to be performed, as a rule, by applying a continuous mechanical compressive action on one of the surfaces of the test specimen.

The required mandrel diameter and the minimum bend angle are specified in the Articles dealing with the various products.

The test is satisfactory if the required bend angle is reached without incipient fracture.

4 Impact test

4.1 Sampling

4.1.1 The impact test is, in general, to be determined on a set of 3 notched specimens.

The longitudinal axis of the notched test specimens can be:

- parallel to the rolling direction of the plate, of the section, or of the piece (longitudinal direction L)
- perpendicular to the rolling direction of the plate or of the piece (transverse direction T)
- parallel to other directions of selection.

The test specimens are to be of the V-notch type and are designated KV.

Depending on whether the Charpy test specimens have been taken in the lengthwise direction (L) or in the crosswise direction (T), the symbol L or T is added, respectively, to the Charpy designation.

4.1.2 The axis of the notch is to be perpendicular to the faces of the plate, section or piece.

The position of the notch is to be not nearer than 25 mm to a flame cut or sheared edge.

4.1.3 For rolled products, the impact test specimens are to be taken, in the case of thickness not higher than 40 mm, retaining the original raw surface of the product or within 2mm from it.

In the case of thickness higher than 40 mm, the test specimens are to be taken with their longitudinal axis located at a position lying 1/4 of the product thickness, or as near as possible to such position.

For forged products, the longitudinal axis of the specimens is to be located in the way of the external third of the distance between the centre (or the inside surface) of the piece and its external surface, considering a typical section of the forging.

4.2 Charpy V-notch specimens

4.2.1 The specimens are to be fully machined at the dimensions and tolerances shown in Fig 8 and Tab 2.

Figure 8 : Charpy V-notch specimen

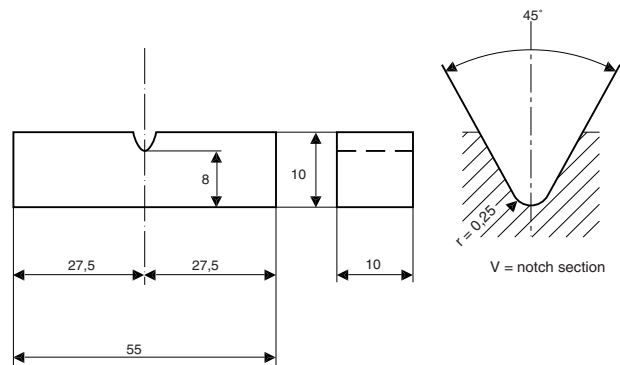

Table 2 : Charpy V-notch specimen

Dimensions	Nominal	Tolerance
Length	55 mm	± 0,60 mm
Width		
• standard specimen	10 mm	± 0,11 mm
• subsize specimen	7,5 mm	± 0,11 mm
• subsize specimen	5,0 mm	± 0,06 mm
Thickness	10 mm	± 0,06 mm
Depth below notch	8 mm	± 0,06 mm
Angle of notch	45 °	± 2°
Root radius	0,25 mm	± 0,025 mm
Distance of notch from end of test specimen	27,5 mm	± 0,42 mm
Angle between plane of symmetry of notch and longitudinal axis of test specimen	90°	± 2°

4.2.2 Specimens with reduced sectional area 10x7,5 or 10x5 may be used when the product thickness does not permit machining of the standard size.

All other dimensions and tolerance are to be as specified in [4.2.1].

In all cases the largest size Charpy specimen possible for the material thickness is to be machined.

The required energy values are given in Tab 3.

4.3 Testing procedure

4.3.1 Tests on V-notch type specimens are to be carried out at or below ambient temperature, in compliance with the requirements of the parts of the Rules relevant to the individual products and uses.

The term "ambient temperature" means any temperature within the range 18 to 28°C.

Where the test temperature is lower than ambient, the temperature of the specimen at the moment of the breaking is to be the specified test temperature, within plus minus 2°C.

The test temperature is to be clearly specified in the testing documents.

Table 3 : Average energy value for reduced specimens

Sectional area of V-notch specimens (mm ²)	Minimum average energy (1)
10 x 10	KV
10 x 7,5	5/6 KV
10 x 5	2/3 KV
(1) KV is the required average value on standard size specimens, as per the Rules. Only one individual value may be below the specified average value, provided it is not less than 70% of such value.	

4.3.2 For impact tests carried out on a set of three specimens, the Charpy impact toughness is the average adsorbed energy, expressed in Joule (J), resulting from the set.

The average of the results on the three specimens is to comply with the value required for the product in question, and one individual test result may be less than the required average value, provided that it is not less than 70% of it.

4.4 Re-test procedure

4.4.1 Where specified the following Charpy re-test procedure will apply.

When the average value of the three initial Charpy V-notch impact specimens fails to meet the stated requirement, or the value for more than one specimen is below the required average value, or when the value of any one specimen is below 70% of the specified average value, three additional specimens from the same material may be tested and the results added to those previously obtained to form a new average. If this new average complies with the requirements and if not more than two individual results are lower than the required average and of these, not more than one result is below 70% of the specified average value, the piece or batch (as specified for each product) may be accepted.

5 Drop weight test

5.1 Definition and specimens dimensions

5.1.1 The drop weight according to ASTM Standard E 208 is used for determination of the NDT (nil ductility transition) temperature.

The NDT is the maximum temperature where the drop weight specimen breaks when tested according to the provisions of the standard.

Drop weight specimens have one of the following dimensions (thickness by width by length, in mm³):

- type P1: 25 x 90 x 360
- type P2: 19 x 50 x 130
- type P3: 16 x 50 x 130.

5.1.2 The following apply, if not otherwise agreed:

- the specimen sides are to be saw-cut or machined (minimum 25 mm distance to flame-cut surface)
- the machining of the sample to obtain the required thickness of the specimen is to be carried out only on one surface; the opposite mill scales surface is to be maintained
- the direction of the specimen in relation to the rolling direction is not important, but all the specimens of the same test series are to have the same orientation.

5.2 Testing procedure

5.2.1 Two test specimens are to be tested at the specified test temperature.

The compression side is to be on the machined side.

Both test specimens are to exhibit no-break performance at the specified temperature.

6 CTOD test (crack tip opening displacement test)

6.1

6.1.1 Unless otherwise agreed, the test is to be performed on specimens of full section thickness according to national or international standards.

Note 1: Internationally accepted standards include BS 7448 Part 1:1991 and ASTM E 1290 1989.

6.1.2 Other fracture mechanics tests intended to check the resistance to brittle fracture of the material may be carried out as required by *Tasneef*

7 Ductility tests for pipes and tubes

7.1 Flattening test

7.1.1 The specimen consists of a ring cut with the ends perpendicular to the axis of the pipe or tube.

The length of the specimen is to be from 10 mm to 100 mm; alternatively, a fixed length of 40 mm may be accepted.

The edges of the test pieces are to be rounded by filing before the test.

7.1.2 The test consists of compressing the specimen between two rigid and parallel flat plates in a direction perpendicular to its longitudinal axis; the plates are to cover the whole specimen after flattening.

It is to be continued until the distance Z between the two plates, measured under load, reaches the value specified.

In the case of welded pipes or tubes, the test is to be carried out with the welded seam positioned at 90° and at 0° to the flattening force.

After flattening, the specimen is not to present any cracks or other flaws; however, small cracks at the ends may be disregarded.

7.2 Drift expanding test

7.2.1 The specimen consists of a tube section having the ends perpendicular to the tube axis; the edges of the end to be tested may be rounded by filing.

7.2.2 For metallic tubes the length L of the specimen is to be equal to twice the external diameter D of the tube, if the angle of the drift is 30° , or equal to $1,5 D$ if the angle of the drift is 45° or 60° .

The test piece may be shorter provided that after testing the remaining cylindrical portion is not less than $0,5 D$.

7.2.3 The test consists of flaring the end of the specimen at ambient temperature and symmetrically, by means of a truncated-cone shaped mandrel of hardened steel having the included angle specified in [7.2.2] (Fig 9).

The mandrel is to be lubricated but is not to be rotated in the pipe during the test.

The mandrel penetration is to continue until the increase in external diameter of the end of the expanded zone reaches the value specified in the requirements relevant to the various products.

The rate of penetration of the mandrel is not to exceed 50 mm/min .

The expanded zone of the specimen is not to present any cracks or other flaws.

Figure 9 : Drift expanding test

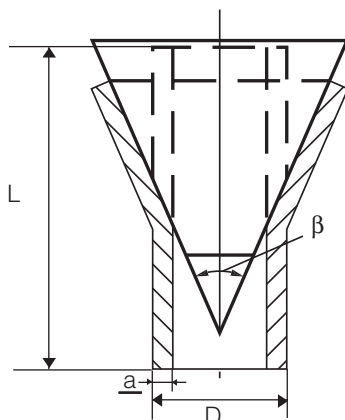

7.3 Flanging test

7.3.1 The specimen consists of a tube section cut with the ends perpendicular to the tube axis and length at least equal to approximately $1,5$ times the external diameter D of the tube.

The test piece may be shorter provided that after testing the remaining cylindrical portion is not less than $0,5 D$.

The edges of the end to be tested may be rounded by filing.

7.3.2 The test is carried out in two stages and consists of symmetrically forming a flange at one end of the specimen by means of a special mandrel of hardened steel; the mandrel is to be lubricated but is not to be rotated in the tube during the test.

During the first stage of flanging, the end of the specimen is expanded by means of a truncated-cone shaped mandrel having an included angle of 90° ; the test is then continued during the second stage using a special forming mandrel to complete the flange.

The test is to be continued until the expanded zone forms a flange perpendicular to the longitudinal axis of the specimen, with an increase in the external diameter of the end of the specimen not less than the value specified (Fig 10).

The rate of penetration of the forming tool is not to exceed 50 mm/min .

The cylindrical and flanged portion of the specimen is not to present any cracks or other flaws.

Figure 10 : Flanging test

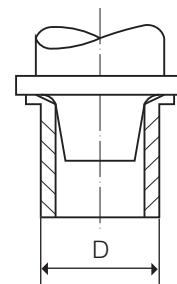

7.4 Ring expanding test

7.4.1 The specimen consists of a tube section cut with the ends perpendicular to the tube axis and the length between 10 and 16 mm .

7.4.2 The specimen is to be expanded to the prescribed diameter or until fracture occurs (Fig 11).

The rate of penetration of the mandrel is not to exceed 30 mm/s .

The expanded specimen is not to reveal unacceptable defects such as cracks, grooves or laminations and is to reach the prescribed expansion.

Figure 11 : Ring expanding test

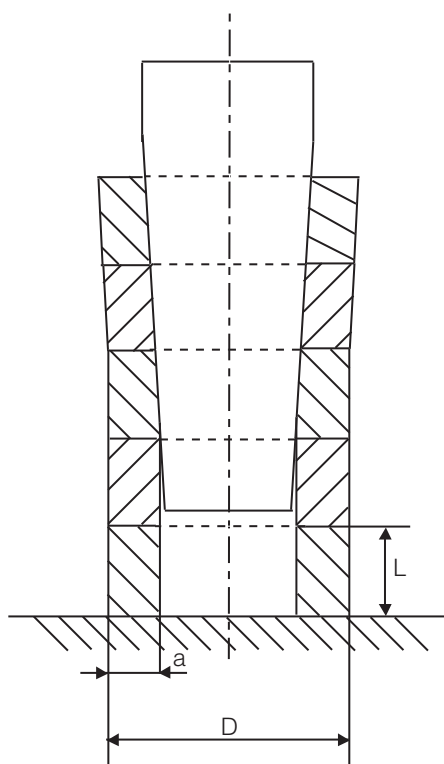

7.5 Ring tensile test

7.5.1 The specimen consists of a tube section with plain and smoothed ends cut perpendicular to the tube axis and with a length of about 15 mm.

7.5.2 The specimen is to be drawn to fracture in a tensile testing machine by means of two mandrels having diameter equal to at least three times the wall thickness of the pipe.

The rate is not to exceed 5mm/s.

In the case of welded pipes the weld seam is to be at 90° to the direction of the tensile load.

The specimen after fracture is not to reveal unacceptable defects such as cracks, groves or laminations and is to show visible deformation at the point of fracture.

7.6 Bend test on pipes and tubes

7.6.1 Where feasible, the test specimen consists of full thickness strips not less than 40 mm in width (which may be machined down to 20 mm width for large thickness pipes) cut perpendicular to the pipe axis.

The edges of the specimen may be rounded to 1,5 mm radius.

The result is considered satisfactory if, after being bent through the required angle in the direction of the original

curvature, the specimen is free from cracks and laminations; however, small cracks on the edges may be disregarded.

7.6.2 For small diameter tubes, in general not exceeding 50 mm, the specimen consists of a tube section of sufficient length.

The specimen is to be bent on a cylindrical mandrel with appropriate procedures as follows, depending on the specification of the product:

- on a mandrel having a diameter 12 times the nominal diameter of the tube until an angle of 90° is reached
- on a mandrel having a diameter 8 times the nominal diameter of the tube, until an angle of 180° is reached.

The specimen after bending is not to present any cracks or other flaws.

8 Other tests and checks

8.1 Strain age embrittlement test

8.1.1 The test is performed according to the following requirements:

- the material is to be deformed, generally by compression (in special cases, deformation under tension may be permitted) until the required shortening (or elongation) (usually 3%, 5% or 10%) is attained
- the material is then to be heat treated in a furnace at 250°C for 1/2 h unless otherwise required
- Charpy impact specimens are to be obtained from the strained and treated material and broken at the specified temperature.

When the deformation is attained by lateral compression, the procedure of artificial aging described above may be applied directly to the individual test specimens.

8.2 Macrographic and micrographic examinations

8.2.1 The following examinations may be required to be performed as a random check for specific steel products:

- macrographic examination for detection of sulphur segregations (sulphur print or "Baumann test") according to ISO 4968
- evaluation of the primary austenitic grain size "McQuaid Ehn test" according to ASTM E 112 58 T Standards. For fine grained steels, the "fine grain" condition is considered satisfied when the grain size is 5 or finer.

Test methods according to other recognised standards are accepted.

8.2.2 The laboratory which carries out the examination is to issue a certificate of the results and photographic documentation of typical zones is to be enclosed.

STEEL AND IRON PRODUCTS

- SECTION 1 ROLLED STEEL PLATES, SECTIONS AND BARS**
- SECTION 2 STEEL PIPES, TUBES AND FITTINGS**
- SECTION 3 STEEL FORGINGS**
- SECTION 4 STEEL CASTINGS**
- SECTION 5 IRON CASTINGS**

SECTION 1

ROLLED STEEL PLATES, SECTIONS AND BARS

1 General

1.1 Application

1.1.1 General

The requirements of this Section apply to hot rolled plates, strips, sections and bars intended for hull, structural applications, boilers, pressure vessels and parts of machinery.

Article [1] specifies the requirements common to all the above-mentioned steel products, while the appropriate specific requirements are indicated in Articles [2] to [9].

1.1.2 Weldability

Steels in accordance with these Rules are weldable subject to the use of suitable welding processes and, where appropriate, to any conditions stated at the time of approval.

1.1.3 Products with through thickness properties

For products intended for welded construction which may be subject to particular stress in the thickness direction, it is suggested, and may be required, that the material satisfies the through thickness properties indicated in Article [9].

For steels specified in Article [9], a further symbol Z is to be added to the steel designation.

1.2 Manufacture

1.2.1 Steel is to be manufactured by the electric furnace, basic oxygen or open hearth processes.

The use of other processes may be specially approved by Tasneef

1.2.2 The steel is to be cast in ingot moulds or by a continuous casting process.

Provision is to be made for sufficient discard such as to ensure:

- at both ends of the ingots, the soundness of the material
- at the transitory zones of continuous casting material, a homogeneous chemical composition along the longitudinal axis.

1.3 Approval

1.3.1 The manufacturing process is to be approved by Tasneef for individual steelmakers, grade of steel and products, as specified in the applicable Articles.

The suitability of each grade of steel for forming and welding is to be demonstrated during the initial approval tests at the steelworks. Approval of the steel works is to follow a scheme accepted by Tasneef

Provisions for the approval are given in the “Rules for the approval of Manufacturers of materials”.

1.4 Quality of materials

1.4.1 All products are to have a workmanlike finish and to be free from surface or internal defects which may impair their proper workability and use.

1.5 Visual, dimensional and non-destructive examinations

1.5.1 Visual, dimensional and, as appropriate, non-destructive examinations are to be performed by the Manufacturer on the materials supplied prior to delivery, as required.

The general provisions indicated in Ch 1, Sec 1, [3.6] and specific requirements for the various products as specified in the relevant Articles of this Section apply.

In the case of doubt about defects [1.4.1], suitable methods of non-destructive examinations may be required by the Surveyor.

1.5.2 The thickness of the plates and strips is to be measured at random locations, whose distance from the longitudinal edge is to be at least 10 mm.

The under thickness requirements are indicated in the Articles relevant to the various products.

1.6 Rectification of surface defects

1.6.1 Rectification of surface defects by grinding

Defects which need to be repaired may be removed by grinding.

The general provisions of Ch 1, Sec 1 and specific requirements for the various products as specified in the relevant Articles of this Section apply.

The repaired areas are to be ground smooth to the adjacent surface of the plate.

The Surveyor may request that the complete removal of defects is verified by suitable non-destructive examination.

1.6.2 Rectification of surface defects by welding

Surface defects of products which cannot be removed as stated in [1.6.1] may be repaired by chipping or grinding followed by welding subject to the Surveyor’s consent and under his supervision.

The general provisions of Ch 1, Sec 1 and specific requirements for the various products as specified in the relevant Articles of this Section apply.

1.7 Condition of supply

1.7.1 The conditions of supply are specified in the Articles relevant to the various products.

Where alternative supply conditions are agreed, the choice of the supply condition, unless otherwise required, is left to the Manufacturer; the condition of supply is always to be mentioned in the testing documentation.

1.7.2 When acceptable as an alternative to normalising, the procedures relevant to controlled or thermo-mechanical rolling process are to be specially approved for individual steelworks.

1.7.3 The following definitions apply to the condition of supply:

a) As Rolled, AR

This procedure involves the rolling of steel at high temperature followed by air cooling. The rolling and finishing temperatures are typically in the austenite recrystallization region and above the normalising temperature. The strength and toughness properties of steel produced by this process are generally less than steel heat treated after rolling or than steel produced by advanced processes.

b) Normalising, N

Normalising involves heating rolled steel above the critical temperature, A_{c3} , and in the lower end of the austenite recrystallization region followed by air cooling. The process improves the mechanical properties of as rolled steel by refining the grain size.

c) Controlled Rolling (CR) or Normalising Rolling (NR): rolling procedure in which the final deformation is carried out in the normalising temperature range with complete recrystallising of the austenite, resulting in a material condition generally equivalent to that obtained by normalising

d) Quenching and Tempering, QT

Quenching involves a heat treatment process in which steel is heated to an appropriate temperature above the A_{c3} and then cooled with an appropriate coolant for the purpose of hardening the microstructure. Tempering subsequent to quenching is a process in which the steel is reheated to an appropriate temperature not higher than the A_{c1} to restore toughness properties by improving the microstructure.

e) Thermo-Mechanical Rolling, TM (Thermo-Mechanical Controlled Processing, TMCP) procedure, which involves the strict control of both the steel temperature and the rolling reduction. Generally, a high proportion of the rolling reduction is carried out close to the A_{r3} transition temperature and may involve the rolling in the dual phase (austenite + ferrite) zone. Unlike controlled rolling (normalising rolling), the properties conferred by thermo-mechanical rolling (TM, TMCP) cannot be reproduced by subsequent normalising or other heat treatment.

f) Accelerated cooling (A_{cC}): rolling procedure with the use of accelerated cooling on completion of rolling (TM) which aims to improve the mechanical properties by controlled cooling, with rates higher than air cooling, immediately after the last rolling pass. The properties conferred by TM and A_{cC} cannot be reproduced by subsequent normalising or other heat treatment.

Direct quenching is excluded from accelerated cooling.

Where CR and TM with/without A_{cC} are applied, the programmed rolling schedules are to be verified by ^{Tasneef} at the time of the steelworks approval, and are to be made available when required by the attending Surveyor. On the Manufacturer's responsibility, the programmed rolling schedules are to be adhered to during the rolling operation (see [2.3.1]). In this regard, the actual rolling records are to be reviewed by the Manufacturer and occasionally by the Surveyor.

When deviation from the programmed rolling schedules or normalising or quenching and tempering procedures occurs, the Manufacturer is to take further measures as required above, to the Surveyor's satisfaction.

1.8 Sampling and tests

1.8.1 General

All products are to be presented for testing in the final supply condition in batches or rolled units as specified in the Articles relevant to the various products.

1.8.2 Sampling

The samples required for the preparation of test specimens are, in general, to be cut from:

- a) the end of the plate or section corresponding to the top position of the ingot, in the case of casting in ingot moulds
- b) any end of the plate or section, where such products are rolled from blooms or billets manufactured by continuous casting, on the understanding that sufficient discard is taken from the transitory zones of the cast beginning and end
- c) both the ends of the coil for plates fabricated in coils.

Samples are to be taken from the following positions:

- plates and flats having width ≥ 600 mm: at approximately one quarter of the width from an edge (see Fig 1)
- flats having width < 600 mm, bulb flats and sections: at approximately 1/3 of the width from an edge (see Fig 2, Fig 3 and Fig 4); alternatively, for channels, beams or bulb angles: on the web, at approximately 1/4 of the width from the centreline (see Fig 4)
- hollow sections: if rectangular, at approximately in the centreline of one side; if circular, at any position along the circumference
- bars: at approximately 1/3 of the radius or half-diagonal from the outer surface; the axis of the sample should be at least 12 mm from the outer surface, except for bars having diameter 25 mm or less, in which case the sample is to be concentric with the bar (see Fig 5).

Figure 1 : Plates and flats

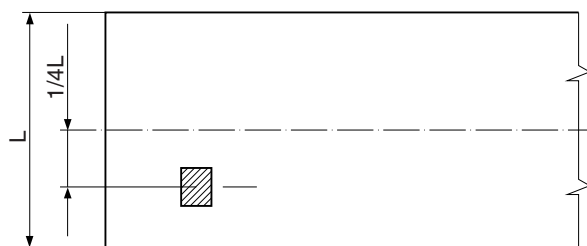

Figure 2 : Bulb flats

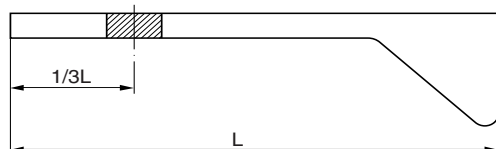

Figure 3 : Angles

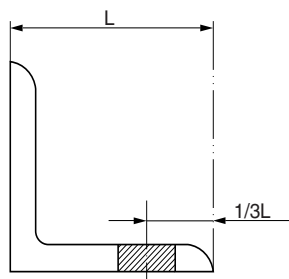
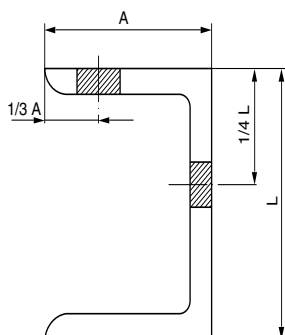

Figure 4 : Sections



1.8.3 Preparation of test specimens

The test specimens are to be cut from the samples with their principal axis parallel (longitudinal test) or perpendicular (transverse test) to the direction of rolling, as required in the Articles relevant to the various products.

For the preparation of test specimens and for the testing procedures, reference is to be made to the applicable requirements of Ch 1, Sec 2.

1.8.4 Tensile test

The results of the test are to comply with the values specified in the Tables relevant to the various products.

If during the tensile test there is no marked yield stress R_{eH} , the 0,2% proof stress $R_{p0,2}$, may be taken as an alternative.

Figure 5 : Bars

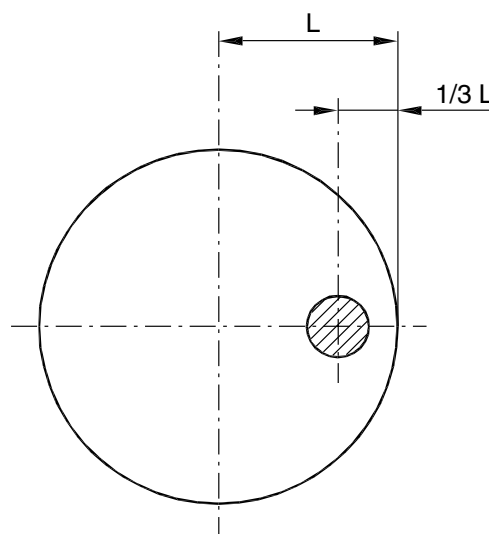

1.8.5 Impact test

The average value is to comply with the minimum average value specified in the Tables relevant to the various products and only one individual value may be less than the average required, provided that it is not less than 70% of it.

The minimum average values are relevant to the standard specimen $10 \times 10 \text{ mm}^2$.

For subsize specimen dimensions and requirements, reference is to be made to Ch 1, Sec 2, [4.2.2].

1.8.6 Re-test procedures

For re-test procedures, reference is to be made to Ch 1, Sec 1, [3.5].

1.9 Identification and marking

1.9.1 The Manufacturer is to adopt a suitable system of identification which enables the product to be traced to its original cast.

1.9.2 All products which have been tested with satisfactory results are to be identified and marked, in addition to Tasneef brand required in Ch 1, Sec 1, [4.1.3], with the following indications:

- Manufacturer's name or trade mark
- identification mark for the grade of steel
- cast number or other marking, which will enable the history of the fabrication of the product to be traced.

Different marking systems are to be agreed with Tasneef

1.10 Documentation and certification

1.10.1 Information required

The testing documentation indicated in Ch 1, Sec 1, [4.2.1] is required and is to contain all the appropriate information.

The ladle analysis is to include the content of refining and alloying elements as applicable.

When a limit of C_{EQ} is prescribed, the content of alloying elements may be omitted unless otherwise required.

1.10.2 Inspection certificate

Before signing Tasneef inspection certificate or endorsing the inspection certificate issued by the Manufacturer (mill sheets), the Surveyor is to be provided by the Manufacturer with a written declaration, stating that the material has been manufactured by a process accepted by Tasneef complies with the applicable requirements and has been satisfactorily tested in accordance with the Rules.

The following wording may be acceptable, either printed or stamped on the delivery documents, with the name of the steel Manufacturer and signed by one of his authorised representatives: "We hereby certify that the material has been made by an approved process and has been satisfactorily tested in accordance with Tasneef Rules".

1.10.3 Casting and rolling in different works

When the steel is rolled, heat treated, etc., in a workshop other than that where it is originally cast, the Surveyor is to be supplied with the steelmaker's certificate stating the manufacturing process, the type of steel, the identification of the cast and the ladle analysis.

The workshop where the steel was produced is to be approved by Tasneef

Surveyors are to have free access to the workshop of the original Manufacturer, who is fully responsible for complying with all applicable requirements.

2 Normal and higher strength steels for hull and other structural applications

2.1 Application

2.1.1 The requirements of this Article apply to weldable normal and higher strength steel hot rolled plates, wide flats, sections and bars intended for use in hull construction and other structural applications.

2.1.2 Provision is made for:

- plates and wide flats of all grades
- sections and bars of all grades not exceeding 50 mm in thickness.

2.1.3 For thickness greater than the above, the requirements may be modified, as appropriate, in the individual cases.

2.2 Steel grades

2.2.1 The steels are classed, on the basis of a minimum yield strength level R_{eH} (N/mm²), into normal strength ($R_{eH} = 235$) and higher strength (32: $R_{eH} = 315 - 36$: $R_{eH} = 355 - 40$: $R_{eH} = 390$).

Normal strength steels are divided into four grades A, B, D and E. For normal strength steels, the letters A, B, D and E mean impact properties at +20, 0, -20 and -40°C, respectively.

Higher strength steels are divided into four grades identified by the letters AH, DH, EH and FH followed by a number related to the yield strength level. For higher strength steels,

the letters AH, DH, EH and FH mean impact properties at 0, -20, -40 and -60°C, respectively.

2.2.2 Steels differing in chemical composition, deoxidation practice, conditions of supply and mechanical properties may be accepted, subject to the special approval of Tasneef. Such steels are to be given a special designation.

2.3 Manufacture

2.3.1 Approval

The Manufacturers are to be approved by Tasneef and the relevant requirements of [1.2] apply.

It is the Manufacturer's responsibility to assure that effective process and production controls in operation are adhered to within the manufacturing specifications. Where control imperfection inducing possible inferior quality of product occurs, the manufacturer is to identify the cause and establish a countermeasure to prevent its recurrence. Also, the complete investigation report is to be submitted to the Surveyor.

For further use, each affected piece is to be tested to the Surveyor's satisfaction.

The frequency of testing for subsequent products offered may be increased at the discretion of Tasneef to gain confidence in the quality.

2.3.2 Deoxidation process

The method of deoxidation is specified in Tab 1 and Tab 2.

2.3.3 Dimensional tolerances

For plates and wide flats, an under thickness tolerance of 0,3 mm is permitted.

For sections and bars, the under thickness tolerance is to be in accordance with the requirements of a recognised international or national standard.

Measurements are to be made as indicated in [1.5.2].

2.3.4 Rectification of surface defects by grinding

Surface defects may be removed by grinding as indicated in [1.6.1] provided that:

- a) the nominal thickness will not be reduced by more than 7% or 3 mm, whichever is the lesser
- b) each single ground area does not exceed 0,25 m²
- c) the total area of local grinding does not exceed 2% of the total surface of the plate.

Adjacent repairs located at a distance less than their mean width are considered as forming a single ground area.

In the case of ground areas lying opposite each other on both surfaces of the plate, the resulting thickness is to satisfy in any place the values indicated in a).

2.3.5 Rectification of surface defects by welding

Surface defects of products which cannot be removed as stated in [2.3.4] may be repaired by chipping or grinding followed by welding subject to the Surveyor's consent and under his supervision, provided that:

- a) after removal of defects and before welding, the thickness of the piece is in no place reduced by more than 20% with respect to the nominal thickness

- b) repair is carried out by an approved procedure and by qualified welders using approved low hydrogen electrodes and the excess weld thickness is subsequently ground smooth to the surface level
- c) no single welded area exceeds 0,125 m² and the sum of all welded areas does not exceed 2% of the total surface area of the plate
- d) after the final grinding the piece is normalised or stress-relieved, where required by the Surveyor. For plates to be supplied in normalised condition, a new normalising heat treatment is required as a rule, except for repairs of negligible size, when the piece had already been normalised before repair; for products obtained by thermo-mechanical rolling processes, the conditions stated at the approval of the rolling process apply.
- e) the repaired plates are presented to the Surveyor for acceptance; in addition to the visual inspection the Surveyor may require the soundness to be verified by ultrasonic, magnetic particle or dye penetrant methods, as appropriate.

2.4 Condition of supply

2.4.1 The products are to be supplied in the condition indicated in Tab 5 and Tab 6 for normal strength steels and Tab 9 and Tab 10 for higher strength steels.

The definition of the supply conditions is given in [1.7.3].

2.5 Chemical composition

2.5.1 General

The chemical composition is determined by the Manufacturer on ladle samples (see Ch 1, Sec 1, [2.2.1]).

2.5.2 Normal strength steels

The chemical composition is to comply with the requirements specified in Tab 1.

2.5.3 Higher strength steels

The chemical composition is to comply with the requirements specified in Tab 2.

At the time of the approval of higher strength steels, an upper limit for carbon equivalent C_{EQ} on the ladle analysis may be specified.

Unless otherwise agreed, the value of C_{EQ} is calculated by the following formula:

$$C_{EQ} = C + \frac{Mn}{6} + \frac{Cr + Mo + V}{5} + \frac{Ni + Cu}{15} \quad \%$$

For steel produced by thermo-mechanical rolling, C_{EQ} is to comply with the requirements of Tab 3.

As an alternative to C_{EQ} , at the discretion of T_{asneef} the cold cracking susceptibility P_{cm} may be used for evaluating the weldability.

P_{cm} is given by the following formula and an upper limit may be agreed at the time of the approval of the steel:

$$P_{cm} = C + \frac{Si}{30} + \frac{Mn}{20} + \frac{Cu}{20} + \frac{Ni}{60} + \frac{Cr}{20} + \frac{Mo}{15} + \frac{V}{10} + 5B \quad \%$$

When a limit of C_{EQ} and P_{cm} is required, the relevant values are to be stated by the Manufacturer and included in the testing documentation for each cast.

Table 1 : Normal strength steels - Chemical composition and deoxidation practice

Steel grade	A	B	D	E
Deoxidation practice for thickness t (mm)	t ≤ 50 mm: any method except rimmed (1) t > 50 mm: killed	t ≤ 50 mm: any method except rimmed t > 50 mm: killed	t ≤ 25 mm: killed t > 25 mm: killed and fine grain treated	killed and fine grain treated
Chemical composition (%) (2) (3) (4)				
C max (5)	0,21 (6)	0,21	0,21	0,18
Mn min (5)	2,5 x C	0,80 (7)	0,60	0,70
Si max	0,50	0,35	0,35	0,35
P max	0,035	0,035	0,035	0,035
S max	0,035	0,035	0,035	0,035
Al (acid soluble) min			0,015 (8) (9)	0,015 (9)
<p>(1) For sections up to a thickness of 12,5 mm, rimmed steel may be accepted subject to the special approval of T_{asneef}</p> <p>(2) When any grade of steel is supplied in the thermo-mechanically rolled condition, variations in the specified chemical composition may be allowed or required by T_{asneef} and are to be stated at the approval.</p> <p>(3) T_{asneef} may limit the amount of residual elements which may have an adverse effect on the working and use of the steel, e.g. copper and tin.</p> <p>(4) Where additions of any other element have been made as part of the steelmaking practice, the content is to be indicated in the ladle analysis certificate.</p> <p>(5) C + 1/6 Mn is not to exceed 0,40%.</p> <p>(6) Max. 0,23% for sections.</p> <p>(7) When Grade B steel is impact tested, the minimum manganese content may be reduced to 0,60%.</p> <p>(8) Al is required for thickness greater than 25 mm.</p> <p>(9) The total aluminum content may be determined instead of acid soluble content. In such cases the total aluminum content is to be not less than 0,020%. Other suitable grain refining elements may be used subject to the special approval of T_{asneef}</p>				

Table 2 : Higher strength steels - Chemical composition and deoxidation practice

Steel grade	AH32, DH32, EH32 AH36, DH36, EH36 AH40, DH40, EH40	FH32, FH36, FH40
Deoxidation practice	killed and fine grain treated	killed and fine grain treated
Chemical composition (%) (1) (5)		
C max.	0,18	0,16
Mn	0,90 - 1,60 (2)	0,90 - 1,60
Si max.	0,50	0,50
P max.	0,035	0,025
S max.	0,035	0,025
Al (acid soluble) min (3) (4)	0,015	0,015
Nb (4)	0,02 - 0,05	0,02 - 0,05
V (4)	0,05 - 0,10	0,05 - 0,10
Ti max. (4)	0,02	0,02
Cu max.	0,35	0,35
Cr max.	0,20	0,20
Ni max.	0,40	0,80
Mo max.	0,08	0,08
N max.		0,009 (0,012 if Al is present)
<p>(1) Alloying elements other than those listed above or exceeding the specified limits may be accepted by ^{Tasneef} when proposed by the steelmaker at the time of approval and their content is to be indicated in the ladle analysis.</p> <p>(2) Up to a thickness of 12,5 mm, the minimum manganese content may be reduced to 0,70.</p> <p>(3) The total aluminium content may be determined instead of the acid soluble content. In such cases the total aluminium content is to be not less than 0,020 %.</p> <p>(4) The steel is to contain aluminium, niobium, vanadium or other suitable grain refining elements, either singly or in any combination. When used singly, the steel is to contain the specified minimum content of the grain refining element. When used in combination, the specified minimum content of at least one grain refining element is applicable; the sum of Nb+V+Ti is not to exceed 0,12%.</p> <p>(5) When any grade of higher strength steel is supplied in the thermo-mechanically rolled condition, variations in the specified chemical composition may be allowed or required by ^{Tasneef} and are to be stated at the approval.</p>		

Table 3 : Carbon equivalent for higher strength steels up to 100 mm in thickness produced by TM process

Steel grade	Carbon equivalent C _{EQ} max. (%) (1)	
	t ≤ 50	50 < t ≤ 100
AH32, DH32, EH32, FH32	0,36	0,38
AH36, DH36, EH36, FH36	0,38	0,40
AH40, DH40, EH40, FH40	0,40	0,42
t = thickness (mm)		
(1) More stringent carbon equivalent limits may be agreed between the Manufacturer and the shipbuilder in individual cases.		

2.6 Mechanical Properties

2.6.1 Normal strength steels

The mechanical properties are indicated in Tab 4.

The number of impact tests to be performed is indicated in Tab 5 for plates and wide flats and Tab 6 for sections and bars.

2.6.2 Higher strength steels

The mechanical properties are indicated in Tab 7.

The condition of supply and the number of impact tests to be performed are indicated in Tab 9 for plates and wide flats and Tab 10 for sections and bars.

2.7 Mechanical Tests

2.7.1 General

Samples for mechanical tests are to be cut from the products in the final supply condition. The tests are to be carried out on pieces selected from batches or on individual pieces as required in [2.7.5] and [2.7.6].

2.7.2 Batch testing

All materials in the batch are to be from the same heat, of the same product type, in the same condition of supply and within the following ranges of thickness and mass:

- difference between minimum and maximum thickness not exceeding 10 mm
- mass not exceeding 50 t.

For products of steel type A intended for secondary applications, the batch composition may not be required to be restricted to material from the same heat, but in such case the mass of the batch is not to exceed 25 t.

2.7.3 Individual testing

For tests on individual pieces the term piece means rolled unit as defined in Ch 1, Sec 1, [3.3.3].

2.7.4 Sampling

For plates and flats having width ≥ 600 mm, the specimens for tensile test are to be taken in the transverse direction and the specimens for the Charpy V impact test in the longitudinal direction (KVL).

In other cases the specimens are to be taken in the longitudinal direction, unless otherwise required by or agreed with Tasneef

The impact test requirements specified on transverse specimens (KVT) are to be fulfilled by the Manufacturer and random checks may be required by Tasneef

Generally, impact tests are not required when the nominal product thickness is less than 6 mm.

For plates fabricated in coils, the tensile and impact tests required are to be duplicated on specimens taken from samples cut at both ends of the coil.

Sampling positions are indicated in [1.8.2].

Additional through thickness tests may be required for special applications and are to be carried out according to the requirements of Article [9].

Table 4 : Normal strength steels - Mechanical properties

Steel grade	Yield stress R_{eH} (N/mm ²) min.	Tensile strength R_m (N/mm ²)	El. A_5 (%)min (1)	Average impact energy (J) min KVL longitudinal - KVT transverse - t = thickness (mm)						
				Test temp (°C)	t \leq 50		50 < t \leq 70		70 < t \leq 100	
					KVL	KVT	KVL	KVT	KVL	KVT
A	235	400/520 (2)	22	+20			34	24	41	27
B	235	400/520	22	0	27	20	34	24	41	27
D	235	400/520	22	-20	27	20	34	24	41	27
E	235	400/520	22	-40	27	20	34	24	41	27

(1) El. : elongation. For full thickness flat tensile test specimens with a width of 25 mm and a gauge length of 200mm, the elongation is to comply with the minimum values given for strength level 32 in Tab 8.

(2) For sections in grade A of all thicknesses, the upper limit for the specified tensile stress range may be exceeded up to a maximum of 540 N/mm².

Table 5 : Normal strength plates and wide flats - Condition of supply and number of impact tests

Steel grade	Condition of supply (1) Batch for impact tests in t () for thickness t (mm) (2)			
	t \leq 25	25 < t < 35	35 \leq t \leq 50	50 < t \leq 100
A	A(-)			(3) (N,TM)(-) NR(50) AR*(50)
B	(4) A (-)	A(50)		(N,TM)(50) NR(25) AR*(25)
D	A(50)		(N,NR,TM)(50)	(N,TM)(50) NR(25)
E	N or TM (each piece)			

(1) Abbreviations:
A : Any
N : Normalised Condition (heat treatment)
NR : Normalising Rolled Condition as an alternative to Normalising
TM : Thermo-Mechanical Rolling
AR* : As Rolled Condition subject to the special approval of Tasneef

(2) One set of impact tests is to be taken from each batch of the weight in t specified in brackets (), from each fraction thereof or from each piece as indicated. When impact tests are not required the indication is (-).

(3) Charpy V-notch tests are generally not required for fine grained grade A products over 50 mm thick N or TM; when required, the rate is at Tasneef discretion.

(4) Charpy V-notch tests are generally not required for Grade B steel with thickness of 25 mm or less; when required, the rate is at Tasneef discretion.

**Table 6 : Normal strength sections and bars
Condition of supply and number of impact tests**

Steel grade	Condition of supply (1) Batch for impact tests in t () for thickness t (mm) (2)		
	t ≤ 25	25 < t ≤ 35	35 < t ≤ 50
A	A (-)		
B	(3) A (-)	A (50)	
D	A (50)		N(50) NR(50) TM(50) AR*(25)
E	N(25) TM(25) AR*(15) NR*(15)		

(1) Abbreviations:
A : Any
N : Normalised Condition (heat treatment)
NR : Normalising Rolled Condition as an alternative to Normalising
TM : Thermo-Mechanical Rolling
AR* : As Rolled Condition subject to the special approval of Tasneef
NR* : Normalising Rolled Condition subject to the special approval of Tasneef

(2) One set of impact tests is to be taken from each batch of the weight in t specified in brackets () or fraction thereof. When impact tests are not required, the indication is (-).

(3) Charpy V-notch impact tests are generally not required for Grade B steel with thickness of 25 mm or less.

Table 7 : Higher strength steels - Mechanical properties

Steel grade	Yield stress R _{eH} (N/mm ²) min.	Tensile strength R _m (N/mm ²)	Elong. A ₅ (%) min. (1)	Average impact energy (J) min. for thickness t (mm)						
				Test temp. (°C)	t ≤ 50		50 < t ≤ 70		70 < t ≤ 100	
					KVL	KVT	KVL	KVT	KVL	KVT
AH32 DH32 EH32 FH32	315	440/570	22	0	31	22	38	26	46	31
- 20				31	22	38	26	46	31	
- 40				31	22	38	26	46	31	
- 60				31	22	38	26	46	31	
AH36 DH36 EH36 FH36	355	490/630	21	0	34	24	41	27	50	34
- 20				34	24	41	27	50	34	
- 40				34	24	41	27	50	34	
- 60				34	24	41	27	50	34	
AH40 DH40 EH40 FH40	390	510/660	20	0	39	26	46	31	55	37
-20				39	26	46	31	55	37	
- 40				39	26	46	31	55	37	
- 60				39	26	46	31	55	37	

(1) For full thickness flat tensile test specimens with a width of 25 mm and a gauge length of 200 mm, the elongation is to comply with the minimum values given in Tab 8.

Table 8 : Elongation (%) on a gauge length of 200 mm for thickness t (mm)

Strength grade	t ≤ 5	5 < t ≤ 10	10 < t ≤ 15	15 < t ≤ 20	20 < t ≤ 25	25 < t ≤ 30	30 < t ≤ 40	40 < t ≤ 50
32	14	16	17	18	19	20	21	22
36	13	15	16	17	18	19	20	21
40	12	14	15	16	17	18	19	20

Table 9 : Higher strength plates and wide flats - Condition of supply and number of impact tests

Steel grade	Grain refining elements	Condition of supply (1)					
		Batch for impact tests in t () for thickness t (mm) up to: (2)					
		12,5	20	25	35	50	100
AH32 (3)	Nb and/or V	A(50)	N(50), NR(50), TM(50)			N(50), NR(25), TM(25)	
AH36 (3)	Al only or with Ti	A(50)	AR*(25)		Not applicable		
			N(50), NR(50), TM(50)			N(50), NR(25), TM(50)	
AH40	Any	A(50)	N(50), NR(50), TM(50)			N(50), TM(50), QT (each length as heat treated)	
DH32 DH36	Nb and/or V Al only or with Ti	A(50)	AR*(25)		Not applicable		
			N(50), NR(50), TM(50)			N(50), NR(25), TM(50)	
DH40	Any	N(50), NR(50), TM(50)				N(50), TM(50), QT (each length as heat treated)	
EH32 EH36	Any	N (each piece) TM (each piece)					
EH40	Any	N (each piece), TM (each piece) QT (each length as heat treated)				N (each piece), TM (each piece), QT (each length as heat treated)	
FH32 FH36	Any	N (each piece), TM (each piece) QT (each length as heat treated)				N (each piece), TM (each piece), QT (each length as heat treated)	
FH40	Any	N (each piece), TM (each piece) QT (each length as heat treated)				N (each piece), TM (each piece), QT (each length as heat treated)	
<p>(1) Abbreviations: A : Any N : Normalised Condition (heat treatment) NR : Normalising Rolled Condition as an alternative to Normalising TM : Thermo-Mechanical Rolling QT : Quenched and Tempered Condition AR* : As Rolled Condition subject to the special approval of Tasneef</p> <p>(2) One set of impact tests is to be taken from each batch of the weight in t specified in brackets (), from each fraction thereof or from each piece as indicated. When impact tests are not required the indication is (-).</p> <p>(3) For Grades AH32 and AH36 steels, a relaxation in the number of impact tests may be permitted by special agreement with Tasneef provided that satisfactory results are obtained from occasional checks.</p>							

2.7.5 Number of tensile tests

One tensile test is to be carried out from one piece for each batch presented or fraction thereof.

In general the specimen is to be taken from a piece selected in the batch among those with the highest thickness.

2.7.6 Number of impact tests

The number of sets of impact tests required is indicated in Tab 5 and Tab 6 for normal strength products and Tab 9 and Tab 10 for higher strength products.

When testing is by batches, the specimens are to be taken from a piece selected among those of the batch having the highest thickness.

The number of sets of specimens for the impact test, each of three specimens, summarised in the above-mentioned Tables, is to be in accordance with the following requirements:

- a) one set is required for each batch of 50, or fraction thereof for the following grades of steel, unless otherwise specified in b):
 - A, for products having thickness ≥ 50 mm
 - B, for products having thickness ≥ 25 mm
 - D, AH32, DH32, AH36, DH36, AH40, DH40
- b) For steel plates of Grades AH40 and DH40 with thickness over 50mm in normalised or TM condition, one set of impact test specimens is to be taken from each batch of 50 t or fraction thereof. For those in QT condition, one set of impact test specimens is to be taken from each length as heat treated.
- c) except for grade A, for products supplied subject to special approval in the as rolled condition (AR*), and for products with thickness higher than 50 mm supplied in the controlled rolled condition (NR), the mass of the batches for the purpose of impact tests is to be 25 t, or a fraction thereof

- d) one set of three impact test specimens is required for:
- each piece for grades E and F in all strengths
 - each batch of 25 t or fraction thereof of sections of grades E and F in all strengths
- e) when, subject to special approval, sections of steel grades E and F in all strengths other than 40 are supplied in the as rolled (AR*) or controlled rolled (NR*) condition, the mass of the batches for the purpose of impact tests is to be 15 t, or a fraction thereof.

Random checks of the impact values may be required at the discretion of the Surveyor.

3 High strength quenched and tempered steels

3.1 Application

3.1.1 The requirements of this Article apply to weldable ferritic high strength quenched and tempered steel plates and wide flats with thickness up to 70 mm.

These requirements may also be applied to products with thickness above 70 mm and to other product forms, such as

sections and tubulars, subject to special agreement with Tasneef

3.2 Steel grades

3.2.1 The requirements apply to carbon-manganese and low alloyed steels.

The steels are classed into six groups indicated by minimum yield strength levels R_{eH} (N/mm²) 420, 460, 500, 550, 620 and 690.

Each group is further subdivided into four grades A, D, E and F based on the impact test temperature.

The letters A, D, E and F mean impact test at 0, -20, -40 and -60°C, respectively.

3.3 Manufacture

3.3.1 Approval

The Manufacturers are to be approved by Tasneef and the relevant requirements of [1.2] apply.

3.3.2 Deoxidation process

The steel is to be fully killed and fine grain treated.

Table 10 : Higher strength sections and bars - Condition of supply and number of impact tests

Steel grade	Grain refining elements	Condition of supply (1)		
		Batch for impact test in t () for thickness t (mm) up to : (2)		
		12,5	20	50
AH32 (3)	Nb and/or V	A(50)	N(50), NR(50), TM(50), AR*(25)	
AH36 (3)	Al only or with Ti	A(50)		N(50), NR(50), TM(50), AR*(25)
AH40	Any	A(50)	N(50), NR(50), TM(50)	
DH32	Nb and/or V	A (50)	N(50), NR(50), TM(50), AR*(25)	
DH36	Al only or with Ti	A(50)		N(50), NR(50), TM(50), AR*(25)
DH40	Any	N(50), NR(50), TM(50)		
EH32	Any	N(25), TM(25), AR*(15), NR*(15)		
EH36				
EH40	Any	N(25), TM(25), QT(25)		
FH32	Any	N(25), TM(25), QT(25), NR*(15)		
FH36				
FH40	Any	N(25), TM(25), QT(25)		
<p>(1) Abbreviations :</p> <p>A : Any</p> <p>N : Normalised Condition (heat treatment)</p> <p>NR : Normalising Rolled Condition as an alternative to Normalising</p> <p>TM : Thermo-Mechanical Rolling</p> <p>QT : Quenched and Tempered Condition</p> <p>AR* : As Rolled Condition subject to the special approval of Tasneef</p> <p>NR* : Normalising Rolled Condition subject to the special approval of Tasneef</p> <p>(2) One set of impact tests is to be taken from each batch of the weight in t specified in brackets () or fraction thereof.</p> <p>(3) For Grades AH32 and AH36 steels, a relaxation in the number of impact tests for acceptance purposes may be permitted by special agreement with Tasneef provided that satisfactory results are obtained from occasional checks.</p>				

3.3.3 Dimensional tolerances and surface conditions

Unless otherwise agreed or specially required, for under thickness tolerances, surface condition and rectification of surface defects, the requirements depend on the applications and are indicated in [2.3.3], [2.3.4] and [2.3.5] for structural applications, in [4.3.3], [4.3.4] and [4.3.5] for applications under pressure and in [6.3.3] for parts of machinery.

Repair by welding is to be specially approved.

3.3.4 Non-destructive examination

For specific applications, ultrasonic examination in accordance with recognised standards may be required.

3.4 Condition of supply

3.4.1 The products are to be supplied in the quenched and tempered condition.

However, thermo-mechanical rolling may be also permitted subject to special approval for thicknesses up to 50 mm, for steels up to grade 550.

For the definition of rolling procedures, see [1.7.3].

3.5 Chemical composition

3.5.1 The chemical composition on ladle analysis is to comply with the requirements specified in Tab 11 and in the approved specification.

The approved specification is also to include the alloying and grain refining elements and the maximum Pcm value (cold cracking susceptibility index), agreed during the initial approval tests of the steel.

The Pcm value is to be calculated from the ladle analysis in accordance with the following formula:

$$P_{cm} = C + \frac{Si}{30} + \frac{Mn}{20} + \frac{Cu}{20} + \frac{Ni}{60} + \frac{Cr}{20} + \frac{Mo}{15} + \frac{V}{10} + 5B \quad \%$$

The alloying and grain refining elements and Pcm value, as applicable, are to be stated by the steelmaker and included in the testing documentation for each cast.

3.6 Mechanical properties

3.6.1 The mechanical properties are specified in Tab 12.

3.7 Mechanical tests

3.7.1 General

Samples for tests are to be cut from the products in the final supply condition. The tests are to be carried out on each rolled unit as heat treated.

The definition of rolled unit is given in Ch 1, Sec 1, [3.3.3].

For continuously heat treated products, special sampling procedures may be agreed at Tasneef discretion.

3.7.2 Sampling

In the case of plates and flats having width ≥ 600 mm, the tensile test and impact test specimens are to be taken in the transverse direction.

In other cases the specimens are to be taken in the longitudinal direction, unless otherwise required by or agreed with Tasneef

3.7.3 Number of tests

The following test specimens are to be taken from each sample:

- 1 tensile test specimen,
- 1 set of 3 Charpy V-notch impact test specimens.

3.7.4 Re-test procedures

For re-test procedures, reference is to be made to Ch 1, Sec 1, [3.5].

4 Steels for boilers and pressure vessels

4.1 Application

4.1.1 The requirements of this Article apply to weldable ferritic steel products (plates, flats, sections and bars) intended for boilers and pressure vessels.

Provision is made for products with thickness up to 60 mm and impact properties at a temperature not lower than -20°C .

These requirements may also be applied to products with thickness above 60 mm subject to agreement with Tasneef

Table 11 : Chemical composition

Yield strength level (N/mm ²)	Steel grade	Chemical composition (%) (1)						
		C max.	Mn max	Si max.	P max.	S max.	Al min. (2)	N max.
420 up to 690	A	0,21	1,70	0,55	0,035	0,035	0,015	0,020
	D - E	0,20	1,70	0,55	0,030	0,030	0,015	0,020
	F	0,18	1,60	0,55	0,025	0,020	0,015	0,020
<p>(1) The content of other elements used for alloying and fine grain treatment is to be within the limits specified for the steel at the time of its approval and is not normally to exceed the following per cent limits: Cu max.= 1,5 ; Cr max.= 2,0 ; Ni max.= 2,0 ; Mo max.= 1,0 ; N max.= 0,020 ; B max.= 0,06 ; Nb max.= 0,06 ; V max.= 0,10 ; Ti max.= 0,20 ; Zr max.= 0,15.</p> <p>(2) The acid soluble Al content may be totally replaced by Nb, V or Ti. The total aluminium content may be determined instead of the acid soluble content and in such cases the total aluminium content is to be not less than 0,020%.</p>								

Table 12 : Mechanical properties

Steel grade	Yield stress R_{eH} (N/mm ²) min. (1)	Tensile strength R_m (N/mm ²)	Elongation A_5 (%) min. (2)	Average impact energy test (J)min.		
				Test temp (C°)	Longitudinal KVL	Transverse KVT
A420	420	530 - 680	18	0	42	28
D420				-20		
E420				-40		
F420				-60		
A460	460	570 - 720	17	0	46	31
D460				-20		
E460				-40		
F460				-60		
A500	500	610 - 770	16	0	50	33
D500				-20		
E500				-40		
F500				-60		
A550	550	670 - 830	16	0	55	37
D550				-20		
E550				-40		
F550				-60		
A620	620	720 - 890	15	0	62	41
D620				-20		
E620				-40		
F620				-60		
A690	690	770 - 940	14	0	69	46
D690				-20		
E690				-40		
F690				-60		

(1) A yield strength to ultimate tensile strength ratio may be required when specified in the steel approval conditions.
(2) For full thickness flat test specimens with a width of 25 mm and a gauge length of 200 mm, the elongation is to comply with the values given in Tab 13. The elongation values specified in Tab 12 and Tab 13 are relevant to tensile specimens taken in the transverse direction. In the case of specimens taken in the longitudinal direction, the elongation values are to be 2 percentage units above those listed in Tab 12 and Tab 13.

Table 13 : Minimum elongation values for flat specimens 25 mm width and 200 mm gauge length

Strength level	Thickness t (mm)						
	t ≤ 10	10 < t ≤ 15	15 < t ≤ 20	20 < t ≤ 25	25 < t ≤ 40	40 < t ≤ 50	50 < t ≤ 70
420	11	13	14	15	16	17	18
460	11	12	13	14	15	15	17
500	10	11	12	13	14	15	16
550	10	11	12	13	14	15	16
620	9	11	12	12	13	14	15
690	9	10	11	11	12	13	14

4.1.2 Special requirements may be specified in the case of applications intended for dangerous substances or particularly severe service conditions.

4.1.3 In the case of applications involving the storage and transport of liquefied gases, the relevant requirements of Pt E, Ch 1, Sec 14 of the Rules apply.

4.2 Steel grades

4.2.1 The requirements apply to carbon and carbon manganese steels and low alloy steels (Mo and Cr-Mo steels).

4.2.2 Carbon and carbon manganese steels are classed into four groups indicated by the minimum ultimate tensile strength R_m (N/mm²): 360, 410, 460 and 510.

Each group may be further subdivided into grades HA, HB and HD, as appropriate, based on the quality level and impact properties.

The letters HA, HB and HD mean impact properties at +20°C, 0°C and -20°C, respectively.

4.2.3 Low alloy steels are designated according to the chemical composition into the grades 0,3Mo - 1Cr0,5Mo - 2,25Cr1Mo.

Two types of 2,25Cr1Mo steel are specified in relation to the heat treatment and consequent mechanical properties.

The figures mean the nominal percentage content of the main alloying elements.

4.3 Manufacture

4.3.1 Approval

Unless otherwise agreed by ^{Tasneef} the Manufacturers are to be approved and the relevant requirements of [1.2] apply.

4.3.2 Deoxidation process

The method of deoxidation is specified in Tab 14 and Tab 15.

4.3.3 Dimensional tolerances

Minus tolerances on the thickness are not normally permitted.

4.3.4 Rectification of surface defects by grinding

Surface defects may generally be removed by grinding as indicated in [1.6.1], provided that the thickness, after grinding, is not less than the nominal thickness.

However the extent of repairs is to be agreed with the Surveyor. Where the thickness is reduced below the nominal thickness given in the approved plans, the possible acceptance and the relevant conditions are subject to special consideration by ^{Tasneef}

4.3.5 Rectification of surface defects by welding

Defects which cannot be removed by grinding may generally be repaired by welding under the conditions given in [1.6.2], except that suitable heat treatment and non-destructive examination are always required after repair.

The purchaser is to be informed as to the extent and position of the repairs carried out on the individual plates.

4.4 Condition of supply

4.4.1 The products are to be supplied in the conditions indicated in Tab 16 for carbon and carbon manganese steels and Tab 17 for low alloy steels.

4.4.2 The products to be processed after supply by hot forming may also be supplied, where agreed, in the as rolled condition.

In such cases heat treatment is to be carried out after hot forming and provision for the mechanical tests indicated in [4.8.4] is to be made.

4.5 Chemical composition

4.5.1 The chemical composition on ladle analysis is to comply with the requirements specified in Tab 14 for carbon and carbon manganese steels and Tab 15 for low alloy steels and/or in the approved specification.

The approved specification is also to include the alloying and grain refining elements (not specified in the above-mentioned Tables).

The relevant elements as applicable are to be stated by the steelmaker and included in the testing documentation for each cast.

For C and C-Mn steels, an upper limit for carbon equivalent C_{EQ} on the ladle analysis may be specified at the time of approval of the individual steels.

Unless otherwise agreed, the value of C_{EQ} is calculated by the following formula:

$$C_{EQ} = C + \frac{Mn}{6} + \frac{Cr + Mo + V}{5} + \frac{Ni + Cu}{15} \quad \%$$

Unless otherwise agreed, when a limit for C_{EQ} is required, the relevant values are to be stated by the steel-maker and included in the testing documentation for each cast.

4.6 Mechanical properties

4.6.1 The mechanical properties are specified in Tab 16 for carbon and carbon manganese steels and Tab 17 for low alloy steels.

Table 14 : Carbon and carbon manganese steels - Chemical composition

Steel grade	Deoxidation	Chemical composition (%) (1)						
		C max	Mn	Si	P max	S max	Al tot. min. (1)	Ni max
360HA	not rimmed	0,16	≥ 0,40	≤ 0,35	0,030	0,030		
360HB	killed	0,16	0,40 - 1,20	0,10 - 0,35	0,030	0,030		
360HD	killed and fine grained	0,16	0,40 - 1,20	0,10 - 0,35	0,030	0,030	0,020	
410HA	not rimmed	0,20	≥ 0,50	≤ 0,35	0,030	0,030		0,30
410HB	killed	0,20	0,50 - 1,40	0,10 - 0,35	0,030	0,030		0,30
410HD	killed and fine grained	0,20	0,50 - 1,40	0,10 - 0,35	0,030	0,030	0,020	0,30
460HB	killed	0,20	0,80 - 1,50	0,10 - 0,40	0,030	0,030		0,30
460HD	killed and fine grained	0,20	0,80 - 1,50	0,10 - 0,40	0,030	0,030	0,020	0,30
510HB	killed	0,22	0,90 - 1,60	0,10 - 0,50	0,030	0,025		0,30
510HD	killed and fine grained	0,20	0,90 - 1,60	0,10 - 0,50	0,030	0,025	0,020	0,30

(1) Nb, V or Ti may be used for grain refining as a complete or partial substitute for Al. The grain refining elements are to be specified at the time of approval; in general Nb and V are not to exceed 0,05 and 0,10%, respectively.
Additional alloying elements are to be submitted for consideration and approval. Residual elements not intentionally added are not to exceed the following limits:
Cu ≤ 0,30% ; Cr ≤ 0,25% ; Mo ≤ 0,10% . Total : Ni + Cu + Cr + Mo ≤ 0,70%

Table 15 : Low alloy steels - Chemical composition

Steel grade	Deoxidation (2)	Chemical composition (%) (1)						
		C	Mn	Si	P max	S max	Cr	Mo
0,3Mo	Si killed	0,12 - 0,20	0,40 - 0,90	0,10 - 0,35	0,030	0,030	≤ 0,30	0,25-0,35
1Cr 0,5Mo	Si killed	0,08 - 0,18	0,40 - 1,00	0,15 - 0,35	0,030	0,030	0,70-1,20	0,40-0,60
2,25Cr 1Mo	Si killed	0,07 - 0,15	0,40 - 0,80	0,15 - 0,50	0,030	0,030	2,00-2,50	0,90-1,10

(1) Residual elements are not to exceed the following limits: Cu ≤ 0,30%, Ni ≤ 0,30% .
(2) Aluminium total max 0,020% for all grades of steel. The aluminium content is to be mentioned in the ladle analysis certificate.

Table 16 : Carbon and carbon manganese steels - Mechanical properties

Steel grade	Heat treatment (1)	Yield stress R _{eH} (N/mm ²) min. for thickness (mm)			Tensile strength R _m (N/mm ²)	Elong.A ₅ (%) min.	Average impact energy (J) min.		
		t ≤ 16	16 < t ≤ 40	40 < t ≤ 60			Test temp (°C)	KVT	KVL
360HA	N or NR	215	205	195	360 - 480	25	+ 20	27	41
360HB		235	225	215			0		
360HD							- 20		
410HA	N or NR	245	235	225	410 - 530	23	+ 20		
410HB		265	255	245			0		
410HD							- 20		
460HB	N or NR	285	270	260	460 - 580	22	0		
460HD		295	285	280			- 20		
510HB	N or NR	345	335	325	510 - 630	21	0		
510HD		355	345	335			-20		

(1) N : Normalising - NR : Normalising Rolling. As an alternative to normalising, the as rolled condition may be accepted for sections, subject to approval of individual steelmakers.

Table 17 : Low alloy steels - Mechanical properties

Steel grade	Heat treatment (1)	Yield stress R_{eH} (N/mm ²) min. for thickness (mm)			Tensile strength R_m (N/mm ²)	Elongation A_5 (%) min. for thickness (mm)		Average impact energy (J) min. at +20°C KVT
		$t \leq 16$	$16 < t \leq 40$	$40 < t \leq 60$		$t \leq 40$	$40 < t \leq 60$	
0,3Mo	N	275	270	260	430 - 600	24	23	31
1Cr 0,5Mo	N + T	300	295	295	450 - 610	20	19	
2,25Cr 0,5Mo	N + T	295	285	275	520 - 670	18	18	
	N+T or Q+T	310	310	310	470 - 620			

(1) N = Normalising; T = Tempering; Q = Quenching

4.7 Mechanical properties at elevated temperatures

4.7.1 The values for the yield stress or 0,2% proof stress ($R_{p0,2}$) at temperatures of 100°C and higher are given in Tab 18.

The above values are for design purposes only. Their verification is in general not required during the testing, unless figures higher than those shown in the above Tables but in accordance with recognised standards are proposed by the steel Manufacturer.

In such cases, the verification is required and the procedures detailed in [4.7.2] and [4.7.3] are to be followed.

4.7.2 When $R_{p0,2}$ is required to be verified, at least one tensile test for each cast is to be carried out at the agreed temperature.

The sample is to be cut from the thickest plate of the cast and, if applicable, at the end of the plate that has shown the lowest figures in the tensile test at ambient temperature.

The sample is to be taken halfway between the edge and the axis of the piece, and the axis of the test specimen is to be located at one quarter of the thickness from one of the rolled surfaces.

The dimensions of the specimens and the testing procedure are to be in accordance with the requirements of Ch 1, Sec 2, [2.1] and Ch 1, Sec 2, [2.2.5], respectively.

The results of tests are to comply with the specified values.

4.7.3 As an alternative to the systematic verification of the required $R_{p0,2}$ as in [4.7.2], it may be agreed with the individual steelmakers to carry out an adequate program of tests on the normal production for each type of steel to be approved.

For Manufacturers and steel types approved on this basis, tensile tests at elevated temperatures are not generally required during the routine testing of the material supplied; they may be required by T_{asneef} as a random check for the confirmation of the approval.

4.7.4 For design purposes only, the estimated values of the stress to rupture in 100000 hours are given in Tab 19 for groups of steels.

4.8 Mechanical tests

4.8.1 General

Unless otherwise agreed (see [4.8.6]), samples for tests are to be cut from the products in the final supply conditions.

4.8.2 Samples from plates and wide flats

One sample is to be taken from one end of each rolled unit when the mass and the length do not exceed 5t and 15m, respectively.

When either of these limits is exceeded, samples are to be cut at both ends of each rolled unit.

The definition of rolled unit is given in Ch 1, Sec 1, [3.3.3].

4.8.3 Samples from sections and bars

One sample is to be taken from each batch homogeneous for cast, section size and condition of supply. Each batch is to contain not more than 50 pieces and its total mass is not to exceed 10 t.

4.8.4 Sampling of test specimens

In the case of plates and wide flats having width ≥ 600 mm, the tensile test and impact test specimens are to be taken in the transverse direction.

In other cases the specimens are to be taken in the longitudinal direction, unless otherwise required by or agreed with T_{asneef}

4.8.5 Number of test specimens

The following test specimens are to be taken from each sample:

- 1 tensile test specimen (2 tests in the case of bars intended for tie rods)
- 1 set of 3 Charpy V-notch impact test specimens (only for grades HB and HD unless otherwise specified)
- 1 tensile test specimen at elevated temperature, for each cast, when required.

Table 18 : Minimum proof stress ($R_{p0,2}$) values at elevated temperatures

Steel grade	Thickness (mm)	$R_{p0,2}$ (N/mm ²) at a temperature (°C) of										
		100	150	200	250	300	350	400	450	500	550	600
360HA (1)	≤ 16	175	172	168	150	124	117	115				
	> 16 ≤ 40	171	169	162	144	124	117	115				
	> 40 ≤ 60	162	158	152	141	124	117	115				
360HB (1) 360HD (1)	≤ 16	204	185	165	145	127	116	110				
	> 16 ≤ 40	196	183	164	145	127	116	110				
	> 40 ≤ 60	179	172	159	145	127	116	110				
410HA (1)	≤ 16	211	208	201	180	150	142	138				
	> 16 ≤ 40	201	198	191	171	150	142	138				
	> 40 ≤ 60	192	188	181	168	150	142	138				
410HB (1) 410HD (1)	≤ 16	235	216	194	171	152	141	134				
	> 16 ≤ 40	228	213	192	171	152	141	134				
	> 40 ≤ 60	215	204	188	171	152	141	134				
460HB (1) 460HD (1)	≤ 16	262	247	223	198	177	167	158				
	> 16 ≤ 40	260	242	220	198	177	167	158				
	> 40 ≤ 60	251	235	217	198	177	167	158				
510HB (1) 510HD (1)	≤ 60	290	270	255	235	215	200	180				
0,3Mo	≤ 60			215	200	170	160	150	145	140		
1Cr 0,5Mo	≤ 60			230	220	205	190	180	170	165		
2,25Cr 1Mo	≤ 60 (2)			235	230	220	210	200	190	180		
	≤ 60 (3)			265	255	235	225	215	205	195		

(1) The values at $R_{p0,2}$ for temperatures ≤ 250°C are for guidance only.
(2) Normalised and tempered
(3) Normalised and tempered or quenched and tempered

4.8.6 Material to be hot worked

When for material to be hot worked after delivery, it is agreed that the heat treatment required will be carried out by the purchaser, the samples are to be submitted by the steelmaker to such treatment before the cutting of test specimens.

In particular cases (when the material is submitted to cold or hot working during fabrication), tests additional to the routine testing may be required on samples in the final condition of the material after fabrication.

These may also include tests on material submitted to artificial aging treatment as indicated in Ch 1, Sec 2, [8.1.1].

5 Ferritic steels for low temperature service

5.1 Application

5.1.1 The requirement of this Article apply to ferritic steel products (plates, flats, sections and bars) intended for cargo tanks, storage tanks, process pressure vessels and systems for liquefied gases and other pressure vessels in general, when impact properties at temperature lower than -20°C are required.

Provision is made for products with thickness up to 60mm.

The extension to higher thicknesses and relevant conditions are subject to agreement with Tasneef

5.1.2 Special requirements may be specified in the case of applications intended for dangerous substances or particularly severe service conditions.

5.1.3 In case of applications involving the storage and transport of liquefied gases, the appropriate requirements of Pt E, Ch 1, Sec 14 also apply.

5.2 Steel grades

5.2.1 The requirements apply to carbon, carbon manganese and Ni alloy steels.

5.2.2 The carbon and carbon manganese steels are classed into four groups indicated by the minimum ultimate tensile strength R_m (N/mm²): 410, 460, 510 and 550.

Each group is further subdivided into two grades, LE and LF, based on the quality level and impact properties.

The letters LE and LF mean impact properties at -40 and -60°C, respectively.

5.2.3 Ni alloy steels are designated according to the chemical composition into the grades: 1,5Ni - 3,5Ni - 5Ni - 9Ni. The figures mean the Ni nominal percentage content.

Table 19 : Average values for stress to rupture in 100000 hours (N/mm²)

Temperature (°C)	Steel grade				
	360 - 410	460 - 510	0,3Mo	1Cr 0,5Mo	2,25Cr 1Mo
380	170	225			
390	155	200			
400	140	175			
410	125	155			
420	110	135			
430	100	115			
440	90	100			
450	75	85	235	285	220
460	(60)	(70)	205	250	205
470	(50)	(60)	175	220	185
480	(40)	(55)	145	190	170
490		(45)	120	160	150
500		(40)	100	135	135
510			80	120	120
520			65	95	105
530			50	80	90
540				60	75
550				50	65
560				40	55
570				30	50
580					45
590					(40)
600					(35)

Note 1: The values shown are estimated average values; the lower limit of the range is approximately 20% less than the average value. The values in brackets for some higher temperatures indicate that the steel is not suitable for continuous use at such temperatures.

5.3 Manufacture

5.3.1 Approval

The Manufacturers are to be approved by ^{Tasneef} (see [1.2]).

5.3.2 Deoxidation process

The steel is to be killed and fine grained.

5.3.3 Dimensional tolerances

For pressure vessels, minus tolerances on thickness are not normally permitted.

5.3.4 Surface conditions

For repairs, the provisions of [4.3.4] and [4.3.5] apply.

Repairs by welding are not normally allowed on 5% or 9% nickel steels.

5.4 Condition of supply

5.4.1 Unless otherwise accepted by ^{Tasneef} carbon and carbon manganese products are to be supplied in normalised (N) condition.

Nickel steel products are to be supplied in the conditions indicated in Tab 23.

5.4.2 The products to be processed after supply by hot working may also be supplied, where agreed, in the as rolled condition.

In such cases heat treatment is to be carried out after forming and provision for the mechanical tests indicated in [4.8.6] is to be made.

5.5 Chemical composition

5.5.1 The chemical composition on ladle analysis is to comply with the requirements specified in Tab 20 and Tab 21 and/or in the approved specification .

The approved specification is also to include the alloying and grain refining elements (not specified in Tab 20).

The content of the above elements, as applicable, is to be stated by the steelmaker for each heat and included in the testing documentation.

For C and C-Mn steels, an upper limit for carbon equivalent C_{EQ} on the ladle analysis may be specified at the time of approval of the individual steels.

Unless otherwise agreed, the value of C_{EQ} is calculated by the following formula:

$$C_{EQ} = C + \frac{Mn}{6} + \frac{Cr + Mo + V}{5} + \frac{Ni + Cu}{15} \quad \%$$

Unless otherwise agreed, when a limit for C_{EQ} is required the relevant values are to be stated by the steelmaker and included in the testing documentation for each cast.

5.6 Mechanical properties

5.6.1 The products are to comply with the mechanical properties specified in Tab 22 and Tab 23.

5.7 Mechanical tests

5.7.1 General

Unless otherwise agreed in the case of materials to be hot worked after delivery [5.4.2], samples for tests are to be cut from the products in the final supply conditions.

5.7.2 Plates and wide flats

One sample is to be taken from one end of each rolled unit when the mass and the length do not exceed 5t and 15m, respectively.

When either of these limits is exceeded, samples are to be cut at both ends of each rolled unit.

The definition of rolled unit is given in Ch 1, Sec 1, [3.3.3].

Table 20 : Carbon and carbon manganese steels - Chemical composition

Steel grade	Chemical composition (%) (1)						
	C max	Mn	Si	P max	S max	Al tot min	Ni max
410 LE	0,18	0,50 - 1,40	0,10 - 0,35	0,030	0,030	0,020	0,30
410 LF	0,16	0,50 - 1,40	0,10 - 0,35	0,030	0,030	0,020	0,80
460 LE	0,18	0,80 - 1,50	0,10 - 0,40	0,030	0,030	0,020	0,30
460 LF	0,16	0,80 - 1,50	0,10 - 0,40	0,030	0,030	0,020	0,80
510 LE	0,18	1,00 - 1,70	0,10 - 0,50	0,030	0,025	0,020	0,30
510 LF	0,16	1,00 - 1,70	0,10 - 0,50	0,030	0,025	0,020	0,80
550 LE	0,18	1,00 - 1,70	0,10 - 0,50	0,030	0,025	0,020	0,30
550 LF	0,16	1,00 - 1,70	0,10 - 0,50	0,030	0,025	0,020	0,80

(1) Nb, V or Ti may be used for grain refining as a complete or partial substitute for Al. The grain refining elements are to be specified at the time of approval; in general Nb and V are not to exceed 0,05 and 0,10 %, respectively. Additional alloying elements are to be submitted for consideration and approval. Residual elements not intentionally added are not to exceed the following limits (%): Cu ≤ 0,30, Cr ≤ 0,15, Mo ≤ 0,10.

Table 21 : Nickel alloy steels - Chemical composition

Steel grade	Chemical composition (1) (2)							
	C max	Mn	Si max	P max	S max	Ni	Cr max	Mo max
1,5 Ni	0,18	0,30 - 1,50	0,35	0,035	0,020	1,30 - 1,70	0,25	0,10
3,5 Ni	0,15	0,30 - 0,90	0,35	0,035	0,020	3,20 - 3,80	0,25	0,10
5,0 Ni	0,12	0,30 - 0,90	0,35	0,035	0,020	4,70 - 5,30	0,25	0,10
9,0 Ni	0,10	0,30 - 0,90	0,35	0,035	0,020	8,50 - 10,0	0,25	0,10

(1) Residual elements are not to exceed the following limits (%): Cu ≤ 0,35 ; V ≤ 0,05 . Total Cr + Cu + Mo ≤ 0,50
(2) Aluminium total not less than 0,020 for all grades of steels. The aluminium content is to be mentioned in the ladle analysis certificate.

Table 22 : Carbon and carbon manganese steels - Mechanical properties

Steel grade	Yield stress R_{eH} (N/mm ²) min. for thickness t (mm)			Tensile strength R_m (N/mm ²)	Elong. A_5 (%) min	Average impact energy (J) min.		
	t ≤ 16	16 < t ≤ 40	40 < t ≤ 60			Temp (°C)	KVT	KVL
410 LE	265	255	245	410 - 530	23	-40	27	41
410 LF	290	280	270	410 - 530	23	-60	27	41
460 LE	295	285	270	460 - 580	22	-40	27	41
460 LF	320	310	300	460 - 580	22	-60	27	41
510 LE	355	345	335	510 - 630	21	-40	27	41
510 LF	355	345	335	510 - 630	21	-60	27	41
550 LE	390	380	375	550 - 670	20	-40	27	41
550 LF	390	380	375	550 - 670	20	-60	27	41

Table 23 : Nickel steels - Mechanical properties

Steel grade	Heat treatment (1)	Yield stress R_{eH} (N/mm ²) min.	Tensile strength R_m (N/mm ²)	Elongation A_5 (%) min.	Average impact energy (J) min.		
					Temp (°C)	KVT	KVL
1,5 Ni	N+T or Q+T	275	490 - 640	22	-80	27	41
3,5 Ni	N+T or Q+T	285	450 - 610	21	-95	27	41
5,0 Ni	N+T or Q+T	390	540 - 740	21	-110	27	41
9,0 Ni	N+N+T or Q+T	490	640 - 790	18	-196	27	41

(1) N=normalising T= tempering Q = quenching

5.7.3 Sections and bars

One sample is to be taken from each batch homogeneous for heat, section size and condition of supply.

Each batch is to contain not more than 50 pieces and its total mass is not to exceed 10 t.

5.7.4 Sampling

In the case of plates and wide flats having width ≥ 600 mm, the tensile test and impact test specimens are to be taken in the transverse direction.

In other cases the specimens are to be taken in the longitudinal direction, unless otherwise required by or agreed with Tasneef

5.7.5 Number of tests

The following test specimens are to be taken from each sample:

- 1 tensile test specimen
- 1 set of 3 Charpy V-notch impact test specimens
- 2 or more drop weight test specimens, when required.

6 Steels for machinery

6.1 Application

6.1.1 The requirements of this Article apply to carbon, carbon manganese, low alloy and alloy rolled steel products intended for use in the construction of structures and parts

of machinery and equipment operating at ambient temperature.

In the case of applications in low or high temperature pressure systems, reference is to be made to the applicable requirements of Articles [5] and [4] respectively.

6.1.2 The products are grouped as follows, depending on the application:

- structural parts of deck equipment
- welded machinery structures such as bedplates, crank-cases, frame entablatures or similar items
- rolled products, such as bars for small shafts, pins, bolts or similar items, when, in the limit of diameters of 250mm, they are accepted in lieu of forgings.

6.2 Steel grades and relevant properties

6.2.1 The type of steels covered by Articles [2], [4], [5] and [7] may be used as appropriate.

Chemical and mechanical properties are to comply with the requirements given therein.

For products having thickness exceeding the maximum thickness considered in the above-mentioned Articles, the following deviations in mechanical properties are permitted:

- the minimum yield stress R_{eH} required is reduced by 1% for every 5 mm thickness over the a.m. maximum

- the minimum elongation A_5 min. required is reduced by 1 unit for thickness over than the a.m. max up to 100 mm and by 2 units for thickness greater than 100 mm.

6.3 Manufacture and condition of supply

6.3.1 Products intended for applications under [6.1.2] a) and [6.1.2] b) are to be manufactured and supplied as indicated in [2.3] and [2.4], [4.3] and [4.4], [5.3] and [5.4], as appropriate.

For products intended for applications under [6.1.2] c), the applicable requirements of Sec 3 apply; unless otherwise agreed, a reduction ration of 6:1 in respect of the original ingot is generally required.

6.3.2 For specific applications, ultrasonic examinations in accordance with approved standards or procedures may be required.

Rolled bars for shaft lines, used in lieu of forgings and having a diameter higher than 150 mm, are to be submitted to non-destructive (ultrasonic and magnetoscopic) examinations.

6.3.3 Unless otherwise agreed or specially required, the under thickness tolerances indicated in Tab 24 apply to plates and wide flats.

6.4 Mechanical tests

6.4.1 For applications under [6.1.2] a) and [6.1.2] b), irrespective of the grade of steel, the testing may be in batches in accordance with the relevant requirements of Article [2].

One tensile test is to be carried out from one piece for each batch presented or fraction thereof.

Unless otherwise required, the impact tests may be omitted.

6.4.2 For applications under [6.1.2] c), the testing procedure is to be in accordance with the requirements of Sec 3, [1.11.4] relevant to forgings.

6.4.3 The results of tensile and impact tests are to comply with requirements of Articles [2], [4] and [5], [7], as applicable.

7 Stainless steel products

7.1 Application

7.1.1 The requirements of this Article apply to austenitic and austenitic-ferritic (duplex) rolled stainless products intended for use in construction of cargo tanks, storage tanks and pressure vessels for chemicals and limitedly to the austenitic grades for liquefied gases.

7.1.2 Austenitic stainless steels are suitable for use both at elevated and low temperatures.

When austenitic stainless steels are proposed for use at elevated temperatures, details of chemical composition, heat

treatment and mechanical properties are to be submitted for consideration and approval.

Unless otherwise specified, austenitic-ferritic stainless steels are in general suitable for service temperature between -20°C and +275°C.

7.1.3 Stainless steel bars may be used for propeller shafts or similar applications under the conditions given in [6.1.2] c).

7.1.4 In cases of applications involving the storage and transport of liquefied gases in bulk, the appropriate requirements of Pt E, Ch 1, Sec 14 apply.

7.2 Steel grades

7.2.1 The requirements apply to Cr-Ni austenitic and austenitic-ferritic stainless steels.

Note 1: Reference is made for designation to the corresponding AISI grade.

Other stainless steel of martensitic types, in accordance with international or national standards, may be accepted for specific applications such as in [7.1.3].

Table 24 : Under thickness tolerance

Nominal thickness t (mm)	Under thickness tolerance (mm)
$5 \leq t \leq 8$	0,4
$8 < t \leq 15$	0,5
$15 < t \leq 25$	0,6
$25 < t \leq 40$	0,8
$t > 40$	1,0

7.3 Manufacture

7.3.1 Approval

Unless otherwise agreed, the Manufacturers of steel intended for the construction of chemical carriers are to be approved by ^{Tasneef} and the relevant requirements of [1.2] apply.

7.3.2 Corrosion resistance

The resistance of tank material to cargoes is under the responsibility of the yard.

Justification of such resistance is to be submitted to ^{Tasneef}

7.3.3 Dimensional tolerances

With the exception of pressure vessels (see [4.3.3]), the minimum tolerance on thickness is to be 0,3 mm.

7.3.4 Surface conditions

Surface defects may be removed by grinding, provided that the plate thickness at the location of the ground zone is not less than the minimum thickness specified in [7.3.3].

Surface defects which cannot be removed by grinding may be generally repaired under the conditions given in [2.3.5], as applicable.

7.4 Condition of supply

7.4.1 All materials are to be supplied in the solution treated condition.

7.5 Chemical composition

7.5.1 The chemical composition on ladle analysis is to comply with the requirements specified in Tab 25.

7.6 Mechanical properties

7.6.1 The mechanical properties are specified in Tab 26.

7.7 Mechanical tests

7.7.1 Batch composition

The products are grouped in batches of 20 tons or fraction thereof, consisting of parts coming from the same cast, the thickness of which differs by no more than 5mm in the case of flat products.

When the batch is made up of plates, the plate selected to take the test specimens is to be one of those of highest thickness.

7.7.2 Sampling

In the case of plates and wide flats having width ≥ 600 mm, the tensile test and impact test specimens are to be taken in the transverse direction.

In other cases the specimens are to be taken in the longitudinal direction, unless otherwise required by or agreed with Tasneef

7.7.3 Number of tests

The following tests are to be carried out:

- one tensile test at ambient temperature
- unless otherwise required, 3 Charpy V-notch impact tests at :
 - 196°C for austenitic steels intended for use in constructions with design temperature lower than -105°C
 - 20°C for austenitic-ferritic steels.

Table 25 : Chemical composition

AISI grade designation	Chemical composition (%) (1)								
	C max	Mn max	Si max	P max	S max	Cr	Ni	Mo	Others
Austenitic									
304 L	0,030	2,0	1,0	0,040	0,030	17,0 - 19,0	9,0 - 12,0	-	
304 LN	0,030	2,0	1,0	0,040	0,030	17,0 - 19,0	8,5 - 11,0	-	$0,14 \leq N \leq 0,22$
316 L	0,030	2,0	1,0	0,040	0,030	16,0 - 18,5	10,0 - 14,0	2,0 - 3,0	
316 LN	0,030	2,0	1,0	0,040	0,030	16,0 - 18,5	11,0 - 13,0	2,0 - 3,0	$0,14 \leq N \leq 0,22$
317 L	0,030	2,0	1,0	0,040	0,030	18,0 - 20,0	14,0 - 16,0	3,0 - 4,0	
317 LN	0,030	2,0	1,0	0,040	0,030	18,0 - 20,0	12,5 - 14,0	3,0 - 4,0	$0,14 \leq N \leq 0,22$
321	0,080	2,0	1,0	0,040	0,030	17,0 - 19,0	9,0 - 13,0	-	$5xC \leq Ti \leq 0,80$
347	0,080	2,0	1,0	0,040	0,030	17,0 - 19,0	9,0 - 13,0	-	$10xC \leq Nb \leq 0,80$
Duplex austenitic-ferritic									
UNS S 31803	0,030	2,0	0,75	0,035	0,010	21,0 - 23,0	4,5 - 6,5	2,5 - 3,0	$0,10 \leq N \leq 0,22$
UNS S 32550	0,030	2,0	0,75	0,035	0,010	24,0 - 26,0	5,5 - 7,5	2,7 - 3,9	$1,0 \leq Cu \leq 2,0$
UNS S 32750	0,030	2,0	0,80	0,035	0,020	24,0 - 26,0	6,0 - 8,0	3,0 - 5,0	$Cu \leq 0,50$
(1) Additional alloying elements are to be submitted for consideration and approval. Residual elements are permitted provided they do not impair the properties, subsequent processing or behaviour in service of the material.									

Table 26 : Mechanical properties

AISI grade designation	Yield strength (N/mm ²) min. (1)		Tensile strength R _m (N/mm ²)	A ₅ (%) min.	Average impact energy (J) min.	
	R _{p0,2}	R _{p1,0}			KVL	KVT
Austenitic					at -196°C	at -196°C
304 L	175	215	470 - 670	45	41	27
304LN	270	310	570 - 790	40		
316L	195	235	490 - 690	45		
316LN	300	340	≥ 590	45		
317L	195	235	490 - 690	40		
317LN	300	340	≥ 590	45		
321	205	245	500 - 750	40		
347	205	245	500 - 750	40		
Duplex austenitic-ferritic					at -20°C	at -20°C
UNS S31803	≥ 470		660 - 800	25	41	27
UNS S32550	≥ 490		690 - 890	25		
UNS S32750	≥ 530		730 - 930	25		

(1) The yield strength R_{p0,2} is in general to be determined

7.8 Metallographic structure inspection

7.8.1 When required, a metallographic structure inspection is to be carried out on sections parallel to the rolling direction of the product, and taken over the whole thickness of the product.

The inspection is to be performed with magnification 200x.

No detrimental intermetallic phase (sigma phase) is to appear in appreciable quantity.

7.9 Intergranular corrosion test

7.9.1 When required, an intergranular corrosion test is to be carried out in compliance with standard ASTM A262 Practice E, or other recognised standards.

The test is to reveal no sensitivity to intergranular corrosion.

7.10 Through thickness tests

7.10.1 Where improved through thickness ductility is required, through thickness tests are to be performed; through thickness tests are generally not required for grades 304L, 304LN, 321 and 347.

7.10.2 Tests and results are to be in accordance with the requirements of Article [9] and [7.10.3].

7.10.3 When the reduction in area is between 25 and 35 per cent, additional metallographic examination or other evidence is required to show that no significant amount of any detrimental phase, such as sigma, is present.

8 Clad steel plates

8.1 Application

8.1.1 The requirements of this Article apply to clad steel plates consisting of a base material "backing steel" and a thinner stainless steel layer "cladding steel" on one or both sides, continuously and integrally bonded, by hot rolling or by explosion bonding.

Provision is made for plates having total thickness higher than 5mm; unless otherwise accepted by Tasneef the thickness of the cladding metal is to be ≥ 2mm.

8.2 Steel grades

8.2.1 The grade of the backing steel is to be chosen from the steel grades for boilers and pressure vessels defined in Article [4].

Other backing steel grades may be accepted subject to Tasneef approval.

8.2.2 The cladding metal in austenitic or austenitic-ferritic stainless steel is to correspond to the grades defined in Article [7].

The use of other grades for stainless steel cladding is to be proposed to Tasneef for prior approval.

8.3 Manufacture

8.3.1 Approval

Clad steel plate Manufacturers are to be approved by Tasneef and the conditions for approval are indicated in the document "Approval of Manufacturers".

8.3.2 Surface condition and dimensional tolerances

The surface condition of the cladding steel is to be in conformity with the specifications of the order.

The Manufacturer is responsible for the inspection of the surface condition, as well as the compliance with the dimensions and the tolerances. However, as the cladding surface condition is important for the corrosion resistance, this inspection of the surface condition carried out by the Manufacturer may be double-checked by a thorough examination made by the Surveyor on the cladding surface.

8.4 Condition of supply

8.4.1 The plates are to be supplied in the same heat treatment condition as stated during the approval.

8.5 Chemical composition

8.5.1 Works' certificates for backing and cladding steels stating the chemical composition are to be supplied by the Manufacturer.

8.6 Mechanical properties

8.6.1 The mechanical properties of the backing material are to comply with the requirements given in Article [4].

The check of the mechanical properties of the cladding material is not required.

8.7 Mechanical tests

8.7.1 Batch composition

The batch is to be composed of plates having the same overall thickness, cladding thickness and cast of backing steel, and mass not exceeding 20 t.

8.7.2 Number of tests

The following tests are to be performed:

- 1 tensile test on the full clad plate
- 2 bend tests on the the full clad plate
- 1 series of impact tests on the backing steel
- 1 shear test on the cladding.

8.7.3 Tensile test

During the tensile test of the full clad plate, the strength is to be not less than the value given by the following formula:

$$R = \frac{R_b \cdot t_b + R_c \cdot t_c}{t}$$

where:

R_b : Nominal minimum R_{eH} or R_m of backing material

R_c : Nominal minimum R_{eH} or R_m of cladding material

t_b : Nominal thickness of backing material

t_c : Nominal thickness of cladding material

t : Nominal thickness of the full clad plate.

If the values resulting from the tensile test (yield stress, ultimate tensile strength) are lower than those given by the

above formula, one additional test is to be performed after removal of the cladding material.

During the tests the requirements for the backing material are to be satisfied.

The value of elongation specified for the backing material applies also to the full clad plate.

8.7.4 Bend tests

The bending conditions (mandrel diameter in general 3 times the plate thickness) are those required for the backing steel grade. One bend test is carried out with the cladding metal on the tensioned side (outer side of bend) and another with the cladding metal on the compressed side (inner side of bend). In the latter test, separations of the cladding not exceeding 25% of the bent portion are admitted.

8.7.5 Shear test

The shear test is carried out in accordance with ASTM A 264. The shear strength is to be at least 140 N/mm².

8.8 Corrosion testing

8.8.1 When required, an accelerated corrosion test is to be carried out to check the resistance of the cladding metal against intergranular corrosion. This corrosion test may be carried out according to a national or an international standard, or to a particular specification, in agreement with *Tasneef* ASTM A 262 practice E may be used.

8.9 Ultrasonic testing

8.9.1 Ultrasonic inspection of the adhesion of the cladding is generally to be performed on plates with an overall thickness (backing + cladding) equal to or greater than 10mm. For overall thickness less than 10mm, the ultrasonic inspection procedure is to be defined in agreement with *Tasneef*

8.9.2 The ultrasonic inspection is to be performed with the following procedures:

- peripheral inspection of a strip of 50mm in width on all the plate edges
- continuous inspection according to a grid with square meshes, 200mm long and parallel to the plate edges.

Random checks may be required by the Surveyor.

8.9.3 The reflection technique is used, with a normal probe having a diameter ranging from 20 to 35 mm and a frequency from 3 to 5 MHz.

8.9.4 Unless otherwise agreed with *Tasneef* non-adhesion areas which do not exceed 50mm x 50mm are tolerated without repair, provided that they are at least 500mm apart.

8.10 Surface defects and repairs

8.10.1 Surface defects may be accepted by the Surveyor when they are not detrimental to the proper use of the product and its corrosion resistance.

8.10.2 All the surface defects are to be ground so as to restore the surface continuity. Nevertheless, such repair by grinding is admitted only if the remaining thickness of the

cladding is at least equal to its guaranteed nominal thickness.

8.10.3 In cases where, after grinding, the cladding thickness is less than the guaranteed nominal thickness, the repair is carried out by welding. The filler metal is to be of the same grade as the cladding and the repair procedure is to be defined in agreement with the Surveyor and preliminarily approved.

8.10.4 If, after grinding of the defect, the remaining thickness of the cladding is less than half of the guaranteed nominal thickness, it is necessary to replace the cladding by tapering and to rebuild the whole of the cladding by welding. Such delicate repair is to be carried out in agreement with the Surveyor and preliminarily approved.

8.11 Adhesion defects in the cladding and repairs

8.11.1 In the case of adhesion defects detected by an ultrasonic inspection as defined in [8.9], the areas of non-adhesion of the cladding which exceed the limits specified in [8.9.4] are to be removed by cutting off or to be repaired.

9 Steels with specified through thickness properties

9.1 Application

9.1.1 The requirements of this Article apply to steel plates and wide flats having thickness not less than 15mm, where improved through thickness ductility in the direction of thickness is required (see [1.1.3]).

The extension to lower thicknesses and relevant conditions are at the discretion of ^{Tasneef}

9.2 Steel grades

9.2.1 The requirements of Article [9] are intended as a supplement to the requirements of Articles [2], [3], [4], [5], [6] and [7] which specify the quality of steels for hull structures, boilers, pressure vessels, low temperature applications and machinery and are intended to have specified minimum ductility in the through thickness or "Z" direction (see Fig 6).

9.2.2 The Z designation is to be given to any steel grade which has been tested according to the above mentioned specifications, and has been successfully subjected to the tests defined in [9.6] and [9.8].

9.2.3 Two "Z" quality steels are specified, Z25 for normal ship applications and Z35 for more severe applications.

Figure 6 : Normal test specimen

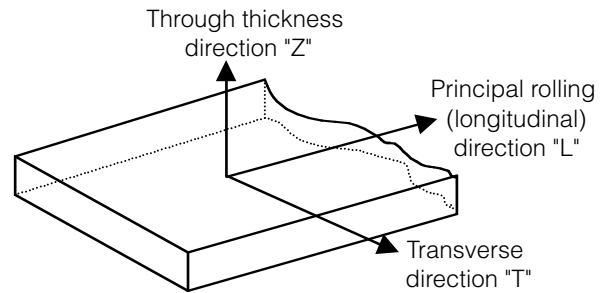

9.3 Manufacture

9.3.1 Approval

Z grade steel Manufacturers are to be approved by ^{Tasneef} for the specific "Z" quality.

The conditions for approval are indicated in the "Rules for the approval of Manufacturers of materials".

The procedure has to take into account the improved steel-making techniques of calcium treatment, vacuum degassing and argon stirring as well as the control of centre-line segregation during continuous casting.

9.4 Chemical composition

9.4.1 In addition to the requirements of the appropriate steel specification, the maximum sulphur content is to be 0,008% determined by the ladle analysis.

9.5 Mechanical properties

9.5.1 The ductility in the direction of thickness is evaluated, for the purpose of these requirements with the value of the reduction area measured on tensile test specimens taken in the through thickness direction of the product and prepared as specified in [9.6.4].

9.6 Test Procedure

9.6.1 General

In addition to the requirements of the appropriate steel specification, preparation of specimens and testing procedures are to be as indicated in the following items [9.6.2] to [9.7.1].

9.6.2 Test sampling

For plates and wide flats, one test sample is to be taken close to the longitudinal centreline of one end of each rolled piece representing the batch and where applicable preferably at the end corresponding to the top of the ingots. See Tab 27 and Fig 7.

9.6.3 Number of tensile test specimens

The test sample must be large enough to accommodate the preparation of 6 specimens. 3 test specimens are to be prepared while the rest of the sample remains for possible retest.

9.6.4 Tensile test specimen dimensions

Round test specimens including the type built-up by welding are to be prepared in accordance with ISO 6892-98, EN 10164-93 or another recognised standard.

Table 27 : Batch size dependent on product and sulphur content

Product	S > 0,005%	S ≤ 0,005%
Plates	Each piece (parent plate)	Maximum 50t of products of the same cast, thickness and heat treatment
Wide flats of nominal thickness ≤ 25mm	Maximum 10t of products of the same cast, thickness and heat treatment	Maximum 50t of products of the same cast, thickness and heat treatment
Wide flats of nominal thickness > 25mm	Maximum 20t of products of the same cast, thickness and heat treatment	Maximum 50t of products of the same cast, thickness and heat treatment

9.7 Tensile test results

9.7.1 The test is considered invalid and a further replacement test is required if the fracture occurs in the weld or heat affected zone.

The minimum average value for the reduction of area of at least 3 tensile test specimens taken in the through thickness direction is to be that shown for the appropriate grade given in Tab 28. Only one individual value may be below the minimum average but not less than the minimum individual value shown for the appropriate grade (see Fig 8).

A value less than the minimum individual value is a cause for rejection.

9.8 Re-test procedure

9.8.1 Fig 8 shows the three cases where a re-test situation is permitted. In these instances three more tensile tests are to be taken from the remaining test sample. The average of all 6 tensile tests is to be greater than the required minimum average with no greater than two results below the minimum average.

In the case of failure after re-test, either the batch represented by the piece is rejected or each piece within the batch is required to be tested.

Table 28 : Reduction of area acceptance values

Grade	Z25	Z35
Minimum average	25%	35%
Minimum individual	15%	25%

9.9 Ultrasonic testing

9.9.1 Ultrasonic testing is required and is to be performed in accordance with either EN 10160 Level S1/E1 or ASTM A 578 Level C.

Ultrasonic testing should be carried out on each piece in the final supply condition and with a probe frequency of 4MHz.

9.10 Marking

9.10.1 Products complying with these requirements are to be marked in accordance with the appropriate steel requirement and in addition with the notation Z25 or Z35 added to the material grade designation, e.g. EH36Z25 or EH36Z35.

9.11 Certification

9.11.1 The following information is required to be included on the certificate in addition to the appropriate steel requirement:

- through thickness reduction in area (%)
- steel grade with Z25 or Z35 notation.

Figure 7 : Plate and wide flat sampling position

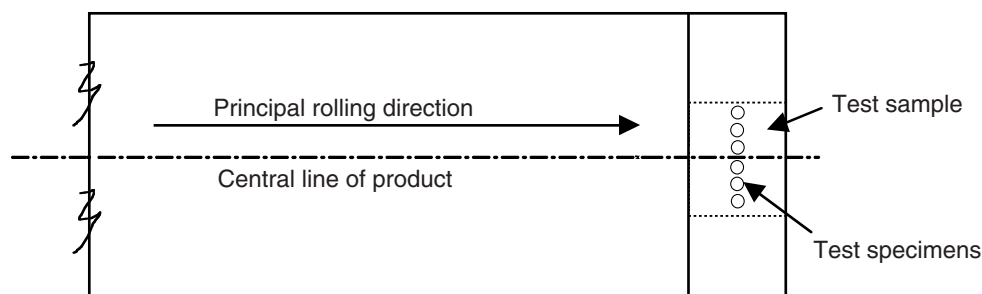
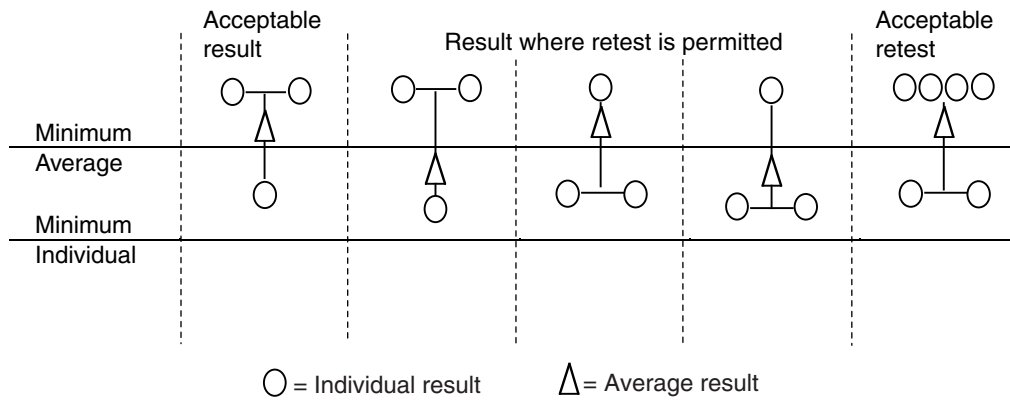

Figure 8 : Diagram showing acceptance / rejection and retest criteria



SECTION 2

STEEL PIPES, TUBES AND FITTINGS

1 General

1.1 Application

1.1.1 General

The requirements of this Section apply to seamless and welded steel pipes, tubes and fittings intended for boilers, pressure vessels and systems operating at ambient, high or low temperature.

Provision is also made for pipes intended for structural applications, at ambient temperature.

Article [1] specifies the requirements common to all the above-mentioned steel pipes, while the appropriate specific requirements are indicated in Articles [2] to [7].

Pipes assigned to Class 3 as defined in Pt C, Ch 1, Sec 8, [1.5] may be manufactured and tested in accordance with recognised national or international standards and, when fabricated by recognised Manufacturers, accepted on the basis of Manufacturer's test certificate (works' certificate W) without testing by ^{Tasneef}

The general term pipes will be used in the following text to mean pipes and tubes.

1.1.2 Special requirements

Special requirements may be specified in cases of applications intended for dangerous substances or particularly severe service conditions.

In cases of applications involving the storage and transport of liquefied gases, the requirements of Pt E, Ch 1, Sec 14 also apply, as appropriate.

1.1.3 Weldability

Steels in accordance with these rule requirements are weldable subject to the use of suitable welding processes and, where appropriate, to any conditions stated at the time of approval.

1.2 Manufacture

1.2.1 Manufacturing process

The steel used is to be manufactured as detailed in Sec 1, [1.2.1].

Unless a specific method is agreed for individual supplies, or specific requirements are given in the relevant Articles, the pipes may be manufactured by one of the following methods:

- a) seamless, hot or cold finished
- b) welded, by automatic processes
- c) welded, as above hot and/or cold finished.

In the case of welded pipes, the following processes are to be used depending on the grade of steel:

- a) electrical resistance (ERW), induction (IW), submerged arc (SAW) welding for carbon and carbon manganese steels
- b) electric tungsten arc process (GTAW), plasma (PAW), submerged (SAW) arc welding for austenitic or austenitic-ferritic steels.

The welding process is to be approved according to the applicable requirements of Ch 5, Sec 2 of the Rules.

Nickel steel pipes are to be manufactured seamless.

Unless otherwise specified, the manufacturing process is left to the discretion of the Manufacturer.

1.3 Approval

1.3.1 Welded pipes and fittings and, unless otherwise specified by ^{Tasneef} seamless pipes and fittings in low alloyed or alloyed steels, intended for high temperature are to be manufactured by approved Manufacturers.

In other cases the Manufacturers are in any event to be recognised by ^{Tasneef}

The approval procedure is indicated in the "Rules for the approval of Manufacturers of materials".

1.4 Quality of materials

1.4.1 All pipes are to have a workmanlike finish consistent with the method of manufacture and to be free from defects and surface or internal imperfections which may impair their use in subsequent fabrication or service.

1.4.2 All pipes are to be reasonably straight and their ends are to be cut perpendicular to the axis without leaving chips or burrs.

1.5 Visual, dimensional and non-destructive examinations

1.5.1 Each pipe is to be submitted by the Manufacturer to visual examination and verification of dimensions.

All pipes intended for severe conditions, such as super heater tubes, pressure cylinders, pressure systems with working pressure higher than 4,0 N/mm², pipes conveying liquefied gases and dangerous media, are to be presented to the Surveyor for visual examination and verification of dimensions.

1.5.2 The dimensional tolerances on the thickness and diameter are to be in accordance with recognised standards.

In welded pipes, the weld reinforcement is to be well faired and within allowable limits.

1.5.3 Welded pipes are to be submitted by the Manufacturer to an appropriate, automatic non-destructive test of welded joints as specified at the approval.

1.6 Rectification of surface defects

1.6.1 Rectification of surface defects by grinding

Small surface defects and imperfections may be removed by grinding, provided that the pipe thickness after repair is within the permissible tolerance and the ground zone is well faired into the adjacent zone.

1.6.2 Rectification of surface defects by welding

Repairs by welding may be accepted at the Surveyor's discretion. The repair procedure is to be submitted for consideration.

The repaired areas are subsequently to be examined by magnetic particle or liquid penetrant methods and/or by other appropriate non-destructive tests.

1.7 Condition of supply

1.7.1 Pipes are to be supplied in the required heat treated or equivalent condition.

Where alternative supply conditions are accepted, the choice of the supply condition, unless otherwise required, is left to the Manufacturer; the condition of supply is always to be mentioned in the testing documentation.

1.7.2 Pipes which are to be expanded after supply are to be annealed at least at their ends.

1.8 Hydrostatic test

1.8.1 With the exception of pipes intended for structural application, each pipe is to be subjected to hydrostatic test at the Manufacturer's works.

The test pressure P, in N/mm², is given by the following formula but the maximum pressure may not be higher than 14 N/mm² :

$$P = \frac{2tf}{D}$$

where :

- D : Nominal outside diameter of the pipe, in mm
- t : Nominal wall thickness of the pipe, in mm
- f : equal to:
 - 0,80 R_{eH} for ferritic steels
 - 0,70 R_{p0,2} for austenitic or austenitic-ferritic steels.

The test pressure is to be maintained for a sufficient time to verify the tightness and at least for 5 seconds.

The test pressure is to be measured by means of a suitable, calibrated pressure gauge.

1.8.2 Unless otherwise agreed, the Manufacturer's certificate of the hydrostatic test is accepted.

The hydrostatic test of pipes intended for boilers, super heaters or pressure systems with working pressure higher than 4,0 N/mm², or conveying liquefied gases and danger-

ous media, may be required to be witnessed by the Surveyor.

1.8.3 Subject to the prior approval of the procedure, a non-destructive test by ultrasonic or eddy current may be accepted as an alternative to the hydrostatic test.

1.9 Sampling and testing

1.9.1 Batch composition

Pipes are to be presented for mechanical and technological tests in the final supply condition and, unless otherwise indicated in the relevant Articles, in batches.

For pipes which are not heat treated, the batch is to consist of pipes of the same size, manufactured by the same procedure, from the same type of steel.

For pipes which are supplied in the heat treated condition, the batches are to consist of pipes of the same size, manufactured from the same type of steel and subjected to the same heat treatment in a continuous furnace or heat treated in the same furnace charge.

For pipes welded by the electric submerged arc welding process, the batch is also to consist of pipes welded with the same welding materials.

For pipes intended for low temperature service, the batch is also to consist of material originating from the same cast.

The size of the batch is to be in accordance with Tab 1.

Table 1 : Number of pipe as made lengths per batch

Outside diameter range (mm)	Maximum number of tubes per batch (1)
D ≤ 114,3	200
114,3 < D ≤ 323,9	100
323,9 < D	50
(1) Residual quantities of up to 10 lengths may be allocated to the other batches presented for testing.	

1.9.2 Sampling

The test samples are to be cut from a length selected at random from each batch, for the tests specified in the various Articles.

The specimens for all or part of the following tests, as detailed in the various Articles, are to be obtained from the individual samples.

- a) mechanical tests
 - tensile test, longitudinal direction
 - tensile test transverse to the weld for pipes with D ≥ 300 mm
 - 3 Charpy V-notch impact tests, longitudinal direction.

For subsize specimens, reference is to be made to Ch 1, Sec 2, [4.2.2]. For pipes having thickness less than 6 mm, reduced specimens having the maximum thickness are to be used.
- b) technological tests
 - flattening test

For welded pipes, two tests are to be carried out; in one test the specimen is to be positioned with the welded joint at 0°, in the other at 90°, to the direction of the force.

The distance between plates to be reached during the test is determined by the following formula:

$$Z = \frac{(1+C)t}{C + \frac{t}{D}}$$

where the value of C is indicated in the tables relevant to the mechanical properties of the various pipes

- a bend test is to be performed in lieu of the flattening test for pipes having $D > 400\text{mm}$ or thickness greater than 15% of D.

For welded pipes, one test is carried out with the outside surface of the pipe in tension and the other with the inside surface of the pipe in tension. The mandrel diameter is indicated in the various Articles and the bend angle is to be equal to 180°.

- flanging or drift expanding test for pipes having $D \leq 150\text{ mm}$ or thickness $\leq 9\text{ mm}$.

1.9.3 Preparation of test specimens

For the preparation of test specimens and for the testing procedures, reference is to be made to the applicable requirements of Ch 1, Sec 2.

1.9.4 Tensile and technological tests

The results of the test are to comply with the values specified in the appropriate tables.

If during the tensile test there is no marked yield stress R_{eHr} , the 0,2% proof stress $R_{p0,2}$ is taken as an alternative.

1.9.5 Impact test

The average value is to comply with the minimum average value required; only one individual value may be less than the average value required, provided that it is not less than 70% of it. The values required for the various products are relevant to standard specimens $10 \times 10\text{ mm}^2$.

For subsize specimens reference is to be made to Ch 1, Sec 2, [4.2.2].

For reduced specimens obtained from pipes having thickness less than 6 mm, the energy required is proportional to the area of the specimen, referring to the specimen $10 \times 5\text{ mm}^2$ and to the energy required for this specimen.

1.9.6 Re-test procedure

For re-test procedures reference is to be made to Ch 1, Sec 1, [3.5].

1.10 Identification and marking

1.10.1 The Manufacturer is to adopt a system of identification which enables the material to be traced to its original cast, as appropriate.

1.10.2 All pipes and tubes are to be identified and marked with the following indications:

- a) Society's brand
- b) Manufacturer's name or trade mark
- c) identification mark for the type of steel
- d) cast number or identification number and/or letters, which will enable the history of the fabrication of the piece or bundle to be traced.

Marking is to be applied by punching. In the case of small wall thickness which may be damaged by punching, alternative methods such as paint, electrical engraving or rubber stamps may be used.

Marking on labels is accepted for small pipes, see Ch 1, Sec 1, [4.1.2].

1.11 Documentation and certification

1.11.1 The testing documentation indicated in Ch 1, Sec 1, [4.2.1] is to be issued and is to include all the required information, as appropriate.

The ladle analysis is to include the content of refining and alloying elements as applicable.

If rimming steel is supplied, this condition is to be stated on the certificate.

1.11.2 When pipes are made from steel produced in a mill other than that where the pipes are manufactured, the Surveyor is to be supplied with a steelmaker's certificate stating the manufacturing process, the grade of steel, the cast number and the relevant ladle analysis.

2 Pipes for pressure systems operating at ambient temperature

2.1 Application

2.1.1 The requirements of this Article apply to seamless and welded carbon and carbon manganese steel pipes, intended for piping systems or pressure vessels operating at ambient temperature or when impact properties at a temperature not lower than -20°C are specified.

2.2 Steel grades

2.2.1 The requirements apply to carbon and carbon manganese steels, which are classed into five groups indicated by the minimum ultimate tensile strength R_{mT} in N/mm^2 : 320, 360, 410, 460 and 510.

Each group is further subdivided into grades HA, HB and HD, based on quality level and impact properties, as applicable.

The letters HA, HB and HD mean impact properties at $+20^\circ\text{C}$, 0°C and -20°C , respectively.

2.3 Condition of supply

2.3.1 Seamless cold finished pipes are to be normalised, while hot finished pipes may be normalised or normalised formed.

Welded pipes are to be supplied in the condition specified at the approval.

At the Manufacturer's discretion, normalising and tempering may be carried out in lieu of normalising; see [1.7].

2.4 Chemical composition

2.4.1 The method of deoxidation and chemical composition on ladle analysis are to comply with the requirements specified in Tab 2.

2.5 Mechanical properties

2.5.1 The mechanical properties are specified in Tab 3.

2.6 Mechanical and technological tests

2.6.1 For pipes intended for pressure cylinders, the tests are to be carried out on each as made length.

Pipes intended for other applications are to be presented in batches, as specified in Tab 1.

One pipe is to be selected from each batch for the required tests as follows:

- a) seamless pipes:
 - one tensile test, longitudinal direction
 - one flattening test or one bend test
 - 3 Charpy V-notch impact tests, longitudinal direction, for pipes having thickness ≥ 11 mm and, when impact properties are required at -20°C , for thickness ≥ 6 mm

- b) welded pipes:
 - one tensile test on base metal, longitudinal direction
 - one tensile test transverse to the weld for pipes with $D \geq 300$ mm
 - two flattening tests or two bend tests
 - 3 Charpy V-notch impact tests, longitudinal direction, for pipes having thickness ≥ 11 mm and, when impact properties are required at -20°C , for thickness ≥ 6 mm.

3 Pipes for structural applications

3.1 Application

3.1.1 Steel pipes for structural application at ambient temperature are to comply with the requirements specified in Article [2], with the exception of the hydrostatic test which is not required.

3.2 Steel grades

3.2.1 Unless otherwise agreed with Tasneef steel grades are to correspond to the types specified in Article [2] with designation 410 HB-HD 460 HB-HD and 510 HB-HD.

The symbol ST is to be added to the steel designation to clearly indicate that pipes are intended for structural application.

4 Pipes for high temperature service

4.1 Application

4.1.1 The requirements of this Article apply to seamless and welded pipes intended for boilers, superheaters and heat exchangers, or pressure parts operating at elevated temperatures.

Table 2 : Chemical composition

Steel grade	Deoxidation	Chemical composition (%) (1)					
		C max	Mn	Si max	P max	S max	Al tot. min. (1)
320 HA	semi-killed or killed (2)	0,16	0,40 - 0,70	0,35	0,040	0,040	
360 HA 360 HB	semi-killed or killed	0,17	0,40 - 1,00	0,35	0,040	0,040	
410 HB	killed	0,21	0,40 - 1,20	0,35	0,040	0,040	
410 HD	killed and fine grained						0,020
460 HB	killed	0,22	0,80 - 1,40	0,35	0,040	0,040	
460 HD	killed and fine grained						0,020
510 HB	killed	0,22	0,60 - 1,80	0,35	0,035	0,035	
510 HD	killed and fine grained						0,020

(1) Nb, V or Ti may be used for grain refining as a complete or partial substitute for Al. The grain refining elements are to be specified at the time of approval; in general Nb and V are not to exceed 0,05 and 0,10%, respectively.
Additional alloying elements are to be submitted for consideration and approval. Residual elements not intentionally added are not to exceed the following limits (%): Ni $\leq 0,30$; Cu $\leq 0,25$; Cr $\leq 0,25$; Mo $\leq 0,10$. Total: Ni + Cu + Cr + Mo $\leq 0,70$

(2) For welded pipes, rimmed steel may also be used, as specified at the approval.

Table 3 : Mechanical properties

Steel grade	Yield stress R_{eH} (N/mm ²) min. for thickness t (mm)			Tensile strength R_m (N/mm ²)	Elong. A_5 (%) min.	Average impact energy (J) min.		Technological tests		
	t ≤ 16	16 < t ≤ 40	40 < t ≤ 60			Test temp (C°)	KVL	Flattening test constant C for t/D		Bend test diameter mandrel
								t/D ≤ 0,15	t/D > 0,15	
320HA	195			320 - 440	25	+20	27	0,09	0,08	4 t
360HA	235	225	215	360 - 500	24	+20				
360HB						0				
410HB	255	245	235	410 - 550	22	0	0,07	0,06		
410HD						-20				
460HB	285	275	265	460 - 580	21 (2)	0				
460HD						-20				
510HB	355	345	(1)	510 - 630	19 (2)	0	34			
510HD						-20				

(1) To be agreed between Manufacturer and purchaser.
(2) For pipes intended for oleodynamic cylinders manufactured in accordance with recognised standards, a minimum value of elongation of 16% may be accepted.

Table 4 : Chemical composition

Steel grade	Chemical composition (%) (1)								
	C max	Mn	Si	P max	S max	Cr	Mo	V	Al tot
320	0,16	0,40-0,70	≤ 0,35	0,030	0,030				
360	0,17	0,40-1,00	≤ 0,35	0,030	0,030				
410	0,21	0,40-1,20	≤ 0,35	0,030	0,030				
460	0,22	0,80-1,40	≤ 0,35	0,030	0,030				
510	0,22	0,60-1,80	≤ 0,35	0,035	0,035				
0,3Mo	0,12-0,20	0,40-0,80	0,10-0,35	0,035	0,035		0,25-0,35		≤ 0,020
0,5Cr 0,5Mo	0,10-0,18	0,50-0,90	0,10-0,35	0,035	0,035	0,40-0,65	0,45-0,60		≤ 0,020
1Cr 0,5Mo	0,10-0,18	0,40-0,70	0,10-0,35	0,035	0,035	0,70-1,10	0,45-0,65		≤ 0,020
2,25Cr 1Mo	0,08-0,15	0,40-0,70	0,10-0,35	0,035	0,035	2,00-2,50	0,90-1,20		≤ 0,020
0,5Cr 0,5Mo 0,25V	0,10-0,18	0,40-0,70	0,15-0,50	0,035	0,035	0,70-1,10	0,45-0,65	0,22-0,28	≤ 0,020

(1) Additional alloying elements are to be submitted for consideration and approval. Residual elements are permitted provided they do not impair the properties, subsequent processing or behaviour in service.
For C and C-Mn steels, the following limits (%) apply: Ni ≤ 0,30 ; Cu ≤ 0,25 ; C ≤ 0,25 ; Mo ≤ 0,10 ; Total: Ni+Cu+Cr+Mo ≤ 0,70. For Mo and Cr-Mo alloy steels, the limits are the following (%): Ni ≤ 0,30 ; Cu ≤ 0,25

4.2 Steel grades

4.2.1 The requirements apply to carbon, carbon-manganese steels and low alloy steels (Mo, Cr-Mo and Cr-Mo-V).

4.2.2 Carbon and carbon manganese steels are classed into four groups which are indicated by the minimum ultimate tensile strength R_m (N/mm²): 320, 360, 410, 460 and 510.

4.2.3 Low alloy steels are designated according to the chemical composition into the grades 0,3Mo - 0,5Mo0,5Cr, 1Cr0,5Mo - 2,25Cr1Mo - 0,5Cr0,5Mo0,25V.

The figures mean the nominal percentage content of the main alloying elements.

4.3 Condition of supply

4.3.1 The products are to be supplied in the conditions indicated in Tab 5.

Table 5 : Mechanical properties - Conditions of supply

Steel grade	Heat Treatment (1)	Yield stress R_{eH} (N/mm ²) min for t (mm)		Tensile strength R_m (N/mm ²)	Elong. A_5 (%) min.	Technological tests			
		t ≤ 40	40 < t ≤ 60			C (3)	Di/D (4)		
							≤ 0,6	0,6 < Di/D ≤ 0,8	> 0,8
320	N or NR	195		320 - 440	25	0,09	12	15	19
360	N or NR	225	215	360 - 500	25	0,09	12	15	19
410	N or NR	245	235	410 - 550	22	0,06	10	12	17
460	N or NR	270	260	460 - 580	21	0,06	8	10	15
510	N or NR	345	(2)	510 - 640	21	0,06	8	10	15
0,3Mo	N	270	260	450 - 600	22	0,07	8	10	15
0,5Cr 0,5Mo	N+T	270	260	440 - 570	22	0,07	8	10	15
1Cr 0,5Mo	N or N+T	290	280	440 - 590	22	0,07	8	10	15
2,25Cr 1Mo	N+T	280	270	450 - 600	20	0,06	8	10	15
	A	205	205	410 - 560	22	0,06	8	10	15
0,5Cr 0,5Mo 0,25V	N+T	300	290	460 - 610	20	0,06	8	10	15

(1) N : normalising - NR : normalising forming - T: tempering - A : annealing.
(2) To be agreed between Manufacturer and purchaser.
(3) Constant C for flattening test.
(4) Expanding or flanging test; increase of outside diameter D, in %, as a function of Di/D.

4.4 Chemical composition

4.4.1 The chemical composition on ladle analysis is to comply with the requirements specified in Tab 4.

Steels are to be killed with the exception of grades 320 and 360 which may be semi-killed.

4.5 Mechanical properties

4.5.1 The mechanical properties and conditions of supply are specified in Tab 5.

4.6 Mechanical properties at elevated temperatures

4.6.1 The values of the yield stress R_{eH} or 0,2% proof stress $R_{p0,2}$ at temperatures of 100°C and higher are given in Tab 6.

The values are for design purposes only. Their verification is in general not required during the testing, unless figures higher than those shown in Tab 6 and in accordance with recognised standards are proposed by the steel Manufacturer.

In such cases, the verification is required and the procedures detailed in [4.6.2] and [4.6.3] are to be followed.

4.6.2 When the $R_{p0,2}$ is required to be verified, at least one tensile test for each cast is to be carried out at the agreed temperature.

In cases of pipes of different thickness, the sample is to be taken from a pipe selected among those of greatest thickness.

The dimensions of the specimens and the testing procedure are to be in accordance with the requirements of Ch 1, Sec 2, [2.1.7] and Ch 1, Sec 2, [2.2.5] respectively.

The results of tests are to comply with the values specified in Tab 6.

4.6.3 As an alternative to the systematic verification of the required $R_{p0,2}$ as in [4.6.2], it may be agreed with the individual steelmakers to carry out an adequate program of tests on the normal production of each steel, in accordance with an ad hoc procedure.

Subsequent to the satisfactory results of the approval tests, tensile tests at elevated temperatures are not generally required during the routine testing of the material supplied but as a random check for the confirmation.

4.6.4 For design purposes only, the estimated values of the stress to rupture in 100000 hours are given in Tab 7 for groups of steels.

4.7 Mechanical and technological tests

4.7.1 For pipes intended for boiler headers, the tests are to be carried out on each as made length.

Other pipes are to be presented in batches and the number is defined in Tab 1.

Two pipes are to be selected from each batch for the required tests, as follows:

- a) seamless pipes and tubes:
 - one tensile test, longitudinal direction
 - one flattening test or one bend test
 - one expanding or flanging test, when required

b) welded pipes:

- one tensile test on base metal, longitudinal direction
- one tensile test transverse to the weld
- two flattening or two bend tests transverse to the weld for pipes with $D \geq 300$ mm
- one expanding or flanging test, when required.

When required in [4.6.1], a tensile test at elevated temperature is to be performed on one sample per cast.

5 Ferritic steel pipes for pressure service at low temperature

5.1 Application

5.1.1 The requirements of this Article apply to seamless and welded steel pipes intended for construction of piping systems, pressure vessels and plants, when impact properties at temperatures lower than -20°C are specified.

Provision is made for pipes with wall thickness up to 40mm.

5.2 Steel grades

5.2.1 The requirements apply to carbon and carbon-manganese steels and nickel alloy steels.

5.2.2 The carbon and carbon-manganese steels are classed into four groups which are indicated by the minimum ultimate tensile strength R_m (N/mm²): 360, 410, 460 and 510.

Each group is further subdivided into two grades LE and LF, based on the quality level and impact properties.

The letters LE and LF mean impact properties at -40°C and -60°C , respectively.

5.2.3 The Ni alloy steels are designated according to the chemical composition into the grades 3,5Ni, 9,0Ni.

The figures mean the Ni nominal percentage content.

5.3 Condition of supply

5.3.1 The pipes are to be supplied in the conditions indicated in Tab 9.

5.4 Chemical composition

5.4.1 The steel is to be killed and fine grained and the chemical composition on ladle analysis is to comply with the requirements specified in Tab 8.

Table 6 : Minimum proof stress ($R_{p0,2}$) values at elevated temperatures

Steel grade	$R_{p0,2}$ (N/mm ²) at a temperature ($^{\circ}\text{C}$) of (1)									
	100	150	200	250	300	350	400	450	500	550
320 HA	170	160	150	125	100	95	90	85		
360 HA	190	175	165	145	120	115	110	105		
410 HA	210	200	190	170	150	140	130	125		
460 HA	235	220	215	195	180	165	160	155		
510 HA	250	240	230	215	195	180	175	170		
0,3Mo	240	235	225	205	175	160	155	150	145	
0,5Cr 0,5Mo (2)										
1Cr 0,5Mo	265	250	245	235	190	180	175	165	155	150
2,25Cr 1Mo (3)	260	250	245	235	230	215	205	195	180	165
2,25Cr 1Mo (4)	110	100	90	85	80	75	70	65	65	70
0,5Cr 0,5Mo 0,25V	260	250	235	215	190	185	175	165	155	145

(1) The values for temperatures $<200^{\circ}\text{C}$ are given for information.
(2) Values to be determined during preliminary approval.
(3) Normalised and tempered condition.
(4) Annealed condition.

Table 7 : Average values for stress to rupture in 100000 hours (N/mm²)

Temperature (°C)	Carbon and carbon manganese steels		Alloy steels				
	360 / 410	460 / 510	0,3Mo	1Cr 0,5Mo	2,25Cr 1Mo		0,5Cr 0,5Mo 0,25V
					N + T (1) (3)	A (2)	
380	170	225					
390	155	200					
400	140	175					
410	125	155					
420	110	135					
430	100	115					
440	90	100					
450	75	85	240	280	220	195	
460	65	70	205	250	205	180	
470	55	60	175	220	185	165	
480	45	55	140	200	170	155	215
490	35	45	115	170	150	140	190
500		40	95	140	135	125	170
510			75	120	120	115	150
520			60	97	105	100	130
530			45	80	90	90	115
540			35	65	76	76	100
550			30	54	68	68	85
560				43	58	58	70
570				35	50	50	55
580					44	44	45

Note 1: The values shown are estimated average values; the lower limit of the range is approximately 20% less than the average value.

(1) N + T = normalising + tempering.
(2) A = annealing.
(3) When the tempering temperature exceeds 750°C, the values relevant to the annealing heat treatment are to be used.

Table 8 : Chemical composition

Steel grade	Chemical composition (%) (1)							Others (3)
	C max	Mn	Si	P max	S max	Ni	Al tot	
360 LE-LF	0,17	0,40 - 1,00	≤ 0,35	0,030	0,025	≤ 0,30 (2)	≥ 0,020	Cr ≤ 0,25 Cu ≤ 0,30 Mo ≤ 0,10
410 LE-LF	0,18	0,60 - 1,30	≤ 0,35	0,030	0,025	≤ 0,30 (2)	≥ 0,020	
460 LE-LF	0,18	0,60 - 1,30	≤ 0,35	0,030	0,025	≤ 0,30 (2)	≥ 0,020	
510 LE-LF	0,20	1,00 - 1,60	≤ 0,35	0,030	0,025	≤ 0,30 (2)	≥ 0,020	
3,5 Ni	0,15	0,30 - 0,90	0,15 - 0,35	0,025	0,020	3,25 - 3,75	-	
9,0 Ni	0,12	0,30 - 0,90	0,15 - 0,35	0,025	0,020	8,50 - 9,50	-	

(1) With the exception of refining elements, additional alloying elements are to be submitted for consideration and approval; residual elements are permitted provided they do not impair the properties, subsequent processing or behaviour in service.
(2) Higher Ni content up to 0,80 % may be agreed for LF grades.
(3) When the pipes are subjected to hot forming: Cu < 0,25.

Table 9 : Mechanical properties and condition of supply

Steel grade	Heat treatment (1)	Yield stress R_{eH} (N/mm ²) min. for t (mm)		Tensile strength R_m (N/mm ²)	Elong. A_5 (%) min.	Average impact energy (J) min.		Technological tests		
		≤ 25	25 < t ≤ 40			Test temp (°C)	KVL	Flattening test constant C for t/D		Bend test diameter mandrel
								t/D ≤ 0,15	t/D > 0,15	
360 LE	N	225	215	360-500	22	-40	27	0,09	0,08	4 t
360 LF						-60				
410 LE	N	255	245	410-550	20	-40	27	0,07	0,06	
410 LF						-60				
460 LE	N	275	265	460-580	20	-40	27			
460 LF						-60				
510 LE	N	345	335	510-630	19	-40	34			
510 LF						-60				
3,5 Ni	N or N+T or Q+T	255	245	450-640	19	-100	34			
9,0 Ni	N+N+T	470	460	640-840	16	-196	41			
9,0 Ni	Q+T	570	560	690-840						

(1) N: Normalising ; N+T: normalising and tempering ; N+N+T: double normalising and tempering ; Q+T: quenching and tempering.

5.5 Mechanical properties

5.5.1 The mechanical properties and conditions of supply are specified in Tab 9.

5.6 Mechanical and technological tests

5.6.1 The pipes are to be presented in batches and the number of pipes per batch is defined in Tab 1.

Two pipes are to be selected from each batch for the required tests, as follows:

- a) seamless pipes and tubes:
 - one tensile test, longitudinal direction
 - one flattening test or one bend test
 - 3 Charpy V-notch impact tests, longitudinal direction, for thickness ≥ 3 mm
- b) welded pipes:
 - one tensile test on base metal, longitudinal direction
 - one tensile test transverse to the weld
 - two flattening tests or two bend tests transverse to the weld for pipes with D ≥ 300 mm
 - 3 Charpy V-notch impact tests, longitudinal direction, for thickness ≥ 3 mm.

6 Austenitic and austenitic-ferritic stainless steel pipes

6.1 Application

6.1.1 The requirements of this Article apply to seamless and welded austenitic and austenitic-ferritic stainless steel

pipes intended for use in the construction of piping systems for chemicals, liquefied gases and bulk chemical tankers.

6.1.2 Austenitic stainless steels are suitable for use at both elevated and low temperatures.

When austenitic stainless steels are proposed for use at elevated temperatures, details of chemical composition, heat treatment and mechanical properties are to be submitted for consideration and approval.

Ferritic austenitic (duplex) steels are suitable for use for service temperatures between -20°C and +275°C.

6.2 Steel grades

6.2.1 The requirements apply to Cr-Ni stainless steels.

Steels are designated according to AISI grades; the corresponding ISO grades are also indicated in Tab 10.

6.3 Condition of supply

6.3.1 The pipes are to be supplied in the solution treated condition.

6.4 Chemical composition

6.4.1 The chemical composition on ladle analysis is to comply with the requirements specified in Tab 10.

6.5 Mechanical properties

6.5.1 The mechanical properties are specified in Tab 11.

Table 10 : Chemical composition

ISO grade designation	AISI grade designation	Chemical composition (%) (1)								
		C max	Mn max	Si max	Pmax	Smax	Cr	Ni	Mo	Others
X2CrNi1810	304L	0,03	2,00	1,00	0,045	0,035	17,0-19,0	9,0-13,0	-	
X5CrNi1810	304	0,07	2,00	1,00	0,045	0,035	17,0-19,0	9,0-13,0	-	
X2CrNiMo1713	316L	0,03	2,00	1,00	0,045	0,035	16,0-18,5	11,0-14,0	2,0-2,5	
X5CrNiMo1713	316	0,07	2,00	1,00	0,045	0,035	16,0-18,5	11,0-14,0	2,0-2,5	
X6CrNiTi1810	321	0,08	2,00	1,00	0,045	0,035	17,0-19,0	9,0-13,0	-	5xC≤Ti≤0,80
X6CrNiNb1810	347	0,08	2,00	1,00	0,045	0,035	17,0-19,0	9,0-13,0	-	10xC≤Nb≤1,0
X2CrNiMoN2253	UNS31803	0,03	2,00	1,00	0,030	0,020	21,0-23,0	4,50-6,50	2,5-3,5	0,08≤N≤0,20

(1) Additional alloying elements are to be submitted for consideration and approval.
Residual elements are permitted provided they do not impair the properties, subsequent processing or behaviour in service of the material.

Table 11 : Mechanical properties

Steel grade	Yield strength (N/mm ²) min. (1)		Tensile strength R _m (N/mm ²)	Elong. A ₅ (%) min	Average impact energy KVL (J) at		Technological tests			
	R _{p0,2}	R _{p1}			-196°C	-20°C	C (2)	Di/D (3)		
								≤ 0,6	0,6<Di/D≤0,8	> 0,8
304L	175	205	460 - 690	30	41		9	15	17	
304	195	235	460 - 690	30	41					
316L	185	215	460 - 690	30	41					
316	205	245	460 - 690	30	41	0,09				
321	195	325	510 - 710	30	41					
347	205	245	510 - 710		41					
UNS 31803	450		620	25		27				

(1) Conventional proof stress; the 0,2% proof stress values are given for information and, unless otherwise agreed, are not required to be verified during the test.
(2) Constant C for flattening test.
(3) Expanding or flanging test; increase of outside diameter D, in %, as a function of Di/D.

6.6 Mechanical and technological tests

6.6.1 Unless they are required to be tested on each length, pipes are to be presented in batches, as specified in Tab 1.

Two pipes are to be selected from each batch for the required tests, as follows:

a) seamless pipes:

- one tensile test, longitudinal direction
- one flattening test or one bend test with mandrel diameter of 3 t
- 3 Charpy V-notch impact tests, longitudinal direction
- one expansion or flanging test, when required

b) welded pipes:

- one tensile test on base metal, longitudinal direction
- one tensile test transverse to the weld for pipes with $D \geq 300$ mm
- two flattening or two bend tests transverse to the weld with mandrel diameter of 3 t
- 3 Charpy V-notch impact tests, longitudinal direction, when required
- one expansion or flanging test when required.

When required, one tensile test at elevated temperature is to be performed on one sample per cast.

Unless otherwise specified for individual cases, the impact test of austenitic stainless steel is required only for service temperature less than -105°C .

6.7 Corrosion tests

6.7.1 For materials used for piping systems for chemicals, the corrosion tests, ASTM A262 Practice E (Copper- copper sulphate sulphuric) or ASTM A262 Practice C (Nitric acid test), as appropriate, may be required to be carried out on two pipes per batch.

Tests in accordance with other recognised standards are accepted, subject to the agreement of ^{Tasneef}

7 Fittings

7.1 Application

7.1.1 The requirements of this Article apply to seamless and welded carbon, carbon manganese, low alloy and alloy steel fittings, fabricated from pipes or plates and intended for piping systems or pressure plants.

7.2 Steel grades and relevant properties

7.2.1 Fittings fabricated from pipes are to meet the requirements of Articles [1] to [6], depending on the applications, with respect to manufacture, chemical composition and mechanical properties. Fittings may be hot or cold formed from sections of pipes.

Fittings fabricated from plates are to meet the requirements of the Articles from Sec 1, [1] to Sec 1, [7], depending on the applications, with respect to manufacture, chemical composition and mechanical properties.

Fittings may be made from sections of plates formed in one or more shells and welded together. The relevant welding process is to be approved.

7.2.2 Unless otherwise required, the material used for the fabrication of the fittings is to be covered by a works' certificate (W).

7.3 Condition of supply

7.3.1 All fittings are to be in the heat treated or hot working condition specified in the various Articles for the corresponding material.

Fittings in ferritic steel manufactured by hot forming may be delivered in the normalised forming condition in lieu of

normalising, provided that evidence is given of the equivalence of such condition; see [1.7.1].

Fittings manufactured by cold forming are in general to be submitted to heat treatment after forming.

A proposal to deliver fittings in the cold formed condition may be considered by ^{Tasneef} to this end, the Manufacturer is to submit detailed information relevant to forming procedure, mechanical properties after forming and destination of the products.

The heat treatment procedure of welded fittings is to be defined during the approval tests.

7.4 Mechanical properties

7.4.1 The mechanical properties of the finished fittings are to comply with the values specified for the starting materials (plate or pipe).

7.5 Mechanical and technological tests

7.5.1 The fittings are to be presented for testing in batches homogeneous for cast and in the number indicated in Tab 1.

A Brinell hardness test HB is to be performed on 10% of the fittings, with a minimum of 3 units, to verify the homogeneity of the batch. The difference in the hardness value may not be greater than 30 units.

Two fittings per batch are to be selected for the mechanical and technological tests specified in Articles [2] to [6] depending on the application.

The tensile tests are to be performed on the hardest and softest fittings.

7.6 Non-destructive examination

7.6.1 Unless otherwise specified during the approval procedure or in the order, checks with radiographic examination are in general to be performed on welded fittings with outside diameter higher than 75 mm, at the Surveyor's discretion.

7.7 Marking and certification

7.7.1 The requirements specified in Article [1] relevant to marking in [1.10] and certification in [1.11] are to be complied with, as appropriate.

SECTION 3

STEEL FORGINGS

1 General

1.1 Application

1.1.1 General

The requirements of this Section apply to steel forgings intended for hull, structural applications, machinery, boilers, pressure vessels and piping systems.

These requirements may also be applied to the testing of semi-finished products, to be further processed by forging, and to rolled products, when these are acceptable in lieu of forged material. See Sec 1, [6].

This Article specifies the requirements common to all the above-mentioned steel products, while the appropriate specific requirements are indicated in Articles [2] to [9].

1.1.2 Mass productions

For mass produced small forgings, the Manufacturer may adopt modified procedures for testing and inspection subject to the approval of ^{Tasneef}

1.1.3 Special requirements

Special requirements may be specified in the case of applications intended for dangerous substances or for particularly severe service conditions.

In the case of applications involving the storage and transport of liquefied gases or fluids at low temperature in general, the appropriate requirements of Pt E, Ch 1, Sec 14 also apply.

1.2 Classification of forgings

1.2.1 For the purposes of this Section, forgings are divided into two Classes depending on their service:

- a) class 1: forgings intended for important applications, such as propeller and shaft line, highly stressed components of propulsion machinery and essential auxiliary machinery (turbine rotors, crankshafts, shafts, hubs, connecting rods, piston rods, cross heads, pinions and gear wheels), rudder stocks and tillers, anchors, cargo gear items subjected to severe stresses, components of pressure vessels and piping systems of class 1 as defined in Part C, etc.; forgings subject to the requirements in [1.1.3].
- b) class 2: forgings subject to testing not included in class 1.

1.3 Manufacture

1.3.1 Manufacturing process

The steel used in the manufacture of forgings is to be made by a process approved by ^{Tasneef}

Adequate top and bottom discards of the ingots are to be made to ensure freedom from piping and harmful segregations in the finished forgings.

Hot forging, to be carried out within the temperature range specified, is to be gradual and uniform and extended, as far as possible, to the final dimensions of the piece.

The plastic deformation is to be such as to ensure soundness, uniformity of structure and satisfactory mechanical properties.

At an appropriate stage of manufacture, after completion of all hot working operations, forgings are to be suitably heat treated to refine the grain structure and to obtain the required mechanical properties.

1.3.2 Reduction ratio

The reduction ratio is to be calculated with reference to the average cross-sectional area of the cast material. Where the cast material is initially upset, this reference area may be taken as the average cross-sectional area after this operation.

Unless otherwise approved, for Class 1 forgings the total reduction ratio is to be at least:

- for forgings made from ingots or from forged blooms or billets, 3:1 where $L > D$ and 1,5:1 where $L \leq D$
- for forgings made from rolled products, 4:1 where $L > D$ and 2:1 where $L \leq D$
- for forgings made by upsetting, the length after upsetting is to be not more than one-third of the length before upsetting or, in the case of an initial forging reduction of at least 1,5:1, not more than one-half of the length before upsetting
- for rolled bars, 6:1.

L and D are the length and diameter, respectively, of the part of the forging under consideration.

1.3.3 Flame and arc-air shaping

The shaping of forgings or rolled slabs and billets by flame cutting, scarfing or arc-air gouging is to be undertaken in accordance with recognised good practice and, unless otherwise approved, is to be carried out before the final heat treatment. Preheating is to be employed when necessitated by the composition and/or thickness of the steel. For certain components, subsequent machining of all flame cut surfaces may be required.

1.3.4 Welding of forgings

When two or more forgings are joined by welding to form a composite component, the proposed welding procedure specification is to be submitted for approval. Welding procedure qualification tests may be required.

1.4 Approval

1.4.1 Class 1 forgings are to be made by a Manufacturer approved by Tasneef

When the approval is not required, the Manufacturer is, in any event, to be recognised on a case-by-case basis.

Provisions on the matter are given in the "Rules for the approval of Manufacturers of materials".

1.5 Quality of materials

1.5.1 All forgings are to be free from surface or internal defects which would be prejudicial to their proper application in service.

The surface finish is to be in accordance with good practice and with any specific requirements of the approved plans or purchase order.

1.6 Visual and dimensional examination

1.6.1 Visual examination

All products are to be submitted by the Manufacturer to visual examination; where applicable this is to include the examination of internal surfaces and bores.

All class 1 forgings are also to be presented to the Surveyor for visual examination.

Unless otherwise stated, the visual examination of class 2 forgings by the Surveyor is not required.

1.6.2 Verification of dimensions

The verification of dimensions and tolerances is the responsibility of the Manufacturer.

Checks of dimensions for verification of compliance with the approved drawings are in general required for important forgings, to the Surveyor's satisfaction.

1.7 Non-destructive examination

1.7.1 General

When required by the applicable Parts of the Rules, the approved plans, the approved procedure of welded composite components or, in particular cases, the Surveyor, appropriate non-destructive tests are also to be carried out and the results reported by the Manufacturer.

All such tests are to be carried out by competent operators qualified according to the requirements of Ch 1, Sec 1, [3.6.4], using reliable and efficiently maintained equipment. The testing procedures, the extent of testing and the acceptance criteria are to be in accordance with the applicable requirements and are to be agreed with Tasneef

IACS Recommendation No. 68 is regarded as an example of an acceptable standard.

The Manufacturer is to provide the Surveyor with a report confirming that the required examinations have been carried out without revealing significant defects; details of the procedure are also to be indicated in the report.

1.7.2 Magnetic and liquid penetrant examination

Magnetic particle or liquid penetrant testing is to be carried out when the forgings are in the finished condition.

Where current flow methods are used for magnetisation, particular care is to be taken to avoid damaging machined surfaces by contact burns from the prods.

Unless otherwise agreed, these tests are to be carried out in the presence of the Surveyor.

1.7.3 Ultrasonic examination

Ultrasonic examination is to be carried out following the final heat treatment and at a stage when the forgings have been machined to a condition suitable for this type of examination.

Both radial and axial scanning are to be carried out, when appropriate for the shape and dimensions of the forging being examined.

Unless otherwise agreed, this examination is to be carried out by the Manufacturer, although Surveyors may request to be present in order to verify that it is performed in accordance with the agreed procedure.

1.8 Rectification of defects

1.8.1 Rectification of defects by grinding

Defects may be removed by grinding or by chipping and grinding provided the component dimensions are acceptable.

The resulting grooves are to have a bottom radius of approximately three times the groove depth and are to be blended into the surrounding surface so as to avoid any sharp contours. Complete elimination of the defective material is to be verified by magnetic particle testing or liquid penetrant testing.

1.8.2 Rectification of defects by welding

Repair by welding of forgings, except crankshaft, forgings may be permitted subject to the prior approval of Tasneef. In such cases, full details of the extent and location of the repair, the proposed welding procedure, heat treatment and subsequent inspection procedures are to be submitted for approval.

For the purpose of the acceptance of the proposed repairs, due consideration is to be given to the type, class and service conditions of the forging.

The forging Manufacturer is to prepare records of repairs and subsequent inspections traceable to each forging repaired. The records are to be presented to the Surveyor and attached to the testing documentation.

1.9 Condition of supply

1.9.1 At an appropriate stage of manufacture, after completion of all hot working operations, forgings are to be suitably heat treated to refine the grain structure and to obtain the required mechanical properties.

Heat treatment is to be carried out in suitable furnaces. See Ch 1, Sec 1, [2.3.1].

If, for any reason, a forging is locally reheated or is subsequently heated for further hot working, the forging is to be submitted to a new heat treatment.

1.9.2 The acceptable heat treatment conditions are indicated in the Articles relevant to the various forged products.

When more than one heat treatment condition is specified, the choice of the supply condition, unless otherwise required, is left to the Manufacturer; the condition of supply is always to be mentioned in the testing documentation.

1.9.3 When the heat treatment is quenching and tempering and the piece cannot be forged near the final dimensions and shape, it is to be worked by rough machining or flame cutting prior to being quenched and tempered.

1.9.4 If a forging is locally reheated, or any straightening operation is performed after the final heat treatment, a subsequent stress relieving heat treatment may be required.

1.9.5 For surface-hardened forgings, full details of the proposed procedure and specification, including the heat treatment of the base material, are to be submitted for approval. The Manufacturer may be required to demonstrate, by tests, that the proposed procedure gives a uniform surface layer of the required hardness and depth [1.11.11] and that it does not impair the soundness and properties of the steel.

1.9.6 The Manufacturer is to maintain records of heat treatment identifying the furnace used, furnace charge, date, temperature and time at temperature. The records are to be presented to the Surveyor on request.

1.10 Pressure test

1.10.1 Forgings subjected to internal pressure are to be subjected to a hydraulic pressure test in compliance with the conditions laid down in the applicable parts of the Rules.

The test pressure is to be measured by means of a suitable calibrated pressure gauge.

The test is to be performed on the forging in the finished condition and before the application of any coating which may conceal the effect of the test.

Unless otherwise agreed, the test of class 1 forgings is to be carried out in the presence of the Surveyor.

A report confirming the satisfactory results of the pressure tests and indicating the relevant testing conditions is to be issued by the Manufacturer.

1.11 Sampling and testing

1.11.1 General

The requirements relevant to the type and number of tests to be carried out are indicated in the Articles relevant to the various products.

Test material, sufficient for the required tests and for possible re-test purposes, is to be provided with a cross-sectional area of not less than that part of the forging which it represents. It is to be taken from forgings in the supply condition except for forgings to be carburised and for those still to be hot worked and/or heat treated at the purchaser's.

For forgings to be carburised after machining, sufficient test material is to be provided both for preliminary tests after forging and for final tests after completion of carburising [5.7.1].

Except for components which are to be carburised or, for hollow forgings where the ends are to be subsequently closed, test material is not to be cut from a forging until all heat treatment has been completed.

For forgings to be hot worked and/or heat treated by the purchaser, the samples to be tested at the Manufacturer's works are to be forged and heat treated accordingly.

1.11.2 Individual testing

In the case of individual testing, the sample is to be integral with each forging and is to be taken from a suitable extension as specified in the various Articles and in accordance with Fig 1 to Fig 10.

Where one forging is subsequently divided into a number of components, all of which are heat treated together in the same furnace charge, this may be regarded for test purposes as one forging and the number of tests required is to be related to the total length and mass of the original multiple forging.

1.11.3 Batch testing

A batch testing procedure may be adopted in the case of normalized forgings with mass up to 1000kg each and quenched and tempered forgings with mass up to 500kg each. A batch is to consist of forgings of similar shape and dimensions, made from the same heat of steel, heat treated in the same furnace charge and with a total mass not exceeding 6 t for normalised forgings and 3 t for quenched and tempered forgings, respectively.

1.11.4 Batch testing for rolled products

When the use of rolled bars as a substitute for forging material is permitted for the construction by machining of small shafts, pins, bolts and similar items of a diameter generally not exceeding 250 mm, a batch testing procedure may be adopted and the batch composition is to be as follows:

- a) class 1:
 - material from the same rolled ingot or bloom provided that where this is cut into individual lengths, these are all heat treated in the same furnace charge, or
 - bars of the same diameter and heat, heat treated in the same furnace charge and with a total mass not exceeding 2,5 t.
- b) class 2: materials of the same type of steel, of approximately the same size and subjected to the same heat treatment; the total mass of batch is not to exceed 4 t.

The test samples are taken from one or more pieces of the batch [1.11.6].

1.11.5 Homogeneity of the batch

Where a batch testing procedure is used, hardness tests may be required at the discretion of the Surveyors to check the homogeneity of the batch [1.11.10] d).

1.11.6 Sampling

The test samples are to have a cross-sectional area not lower than the part of the forging they represent and are to be located, as a rule, on the top ingot side.

In the case of individual testing [1.11.2], the number and position of samples necessary for the required tests are indicated in the Articles relevant to the various products.

In the case of batch testing [1.11.3], one sample at least is to be taken from the forging representative of the batch; where the number of pieces in the batch exceeds 20, two samples are to be taken.

A set of specimens is to be cut from each sample, for the execution of:

- a) one tensile test
- b) three Charpy impact tests V- or U-notch, when required in the Articles relevant to the various products.

1.11.7 Preparation of test specimens

Test specimens are to be cut from the samples with their principal axis mainly parallel (longitudinal tests) or mainly perpendicular (transverse test) to the principal direction of fibre deformation, as required in the Articles relevant to the various products.

Unless otherwise agreed, the longitudinal axis of the test specimens is to be located as follows:

- a) for thickness or diameter up to maximum 50mm, the axis is to be at the mid-thickness or the centre of the cross-section
- b) for thickness or diameter greater than 50mm, the axis is to be at one quarter thickness (mid-radius) or 80mm, whichever is the lesser, below any heat treated surface.

At the discretion of ^{Tasneef} specimen locations in the section different from those above may be agreed in some cases, e.g. forgings of substantial diameter or thickness, specific steels or heat treatments; in such cases, the values required may be modified accordingly on a case-by-case basis, in consideration in particular of the metallurgical structure and the specimens representativeness with regard to the in-service stress conditions.

For the tensile test, preference is to be given to cylindrical specimens.

For impact test specimens the notch is, in general, to be machined on the side of the specimen perpendicular to the nearest outside surface of the forging or to its tangent in correspondence.

Hardness tests are generally be of the Brinell type.

For the preparation of test specimens and relevant testing procedure, reference is to be made to the applicable requirements of Ch 1, Sec 2.

1.11.8 Tensile test

The results of the tensile test at ambient temperature are to comply with the requirements of the appropriate Tables, or of the approved specification when steels other than those specified in these Rules are accepted.

The Tables give the minimum requirements corresponding to different strength levels but it is not intended that these values should necessarily be regarded as specific rule grades.

The strength levels are given in multiples of 40 N/mm² for C and C-Mn steels, and of 50 N/mm² for alloy steels.

Forgings may be supplied to any specified minimum tensile strength selected within the general limits specified but subject to any additional requirements of the relevant construction Rules.

Where it is proposed to use a steel with a specified minimum tensile strength intermediate to those given, corresponding minimum values for the other properties may be obtained by interpolation.

For the properties at elevated temperatures and their verification, when required, see [7.6].

1.11.9 Impact test

The average value of a set of 3 tests is to comply with the average value required.

Only one individual value may be lower than the average value required, provided that it is not less than 70% of it.

The minimum average values for impact tests are relevant to standard specimens 10x10mm².

1.11.10 Hardness tests

Unless otherwise specified, hardness tests may be required, to Surveyor's satisfaction, on the following items:

- a) quenched and tempered gear forgings after completion of heat treatment and prior to machining the gear teeth [5.6.2]
- b) surface-hardened gear forgings after the teeth have been ground to the finished profile [5.7.2]
- c) surface-hardened forgings in general
- d) batch tested forgings:
 - class 1 forgings: at least one hardness test on each forging
 - class 2 forgings: random checks only.

The results of hardness tests required under a) and d) are to be in agreement with the appropriate values given for information in Tab 4.

The results of hardness tests required under b) and c) are to comply with the approved specification.

1.11.11 Hardness checks on additional tests samples

When required by the conditions of approval for surface-hardened forgings, additional hardness checks are to be carried out on test samples processed at the same time as the forgings they represent. These test samples are subsequently to be sectioned in order to determine the hardness, shape and depth of the locally hardened zone, which are to comply with the approved specification.

1.11.12 Re-test procedures

Samples for possible re-tests are to be taken as near as practicable to the specimens used for the original tests; however, at the discretion of the Surveyors, they may also be taken from other positions or pieces deemed representative of the forging or batch.

Re-test procedures are specified in Ch 1, Sec 1, [3.5].

1.12 Identification and marking

1.12.1 The Manufacturer is to adopt a system of identification which will enable all finished forgings to be traced to

the original cast and their manufacturing and the Surveyor is to be given full facilities for so tracing the forgings when required.

All forgings which have been tested and inspected with satisfactory results are to be clearly marked by the Manufacturer with the following details:

- a) Manufacturer's name or trade mark
- b) Society's brand
- c) identification mark for the grade of steel
- d) cast number or other marking which will enable the history of the fabrication of the forging to be traced
- e) additional, optional marks such as file number and code of local inspection office, Surveyor's personal brand
- f) test pressure, where applicable.

Modified arrangements for identification and marking of small forgings manufactured in large numbers may be agreed with the Surveyor.

1.13 Documentation and certification

1.13.1 The testing documentation indicated in Ch 1, Sec 1, [4.2.1] is to be issued and is to include all the information, as appropriate.

The ladle analysis is to include the content of refining and alloying elements, as applicable.

Where applicable, the reports relevant to the non-destructive examination [1.7.1], weld repair [1.8.2] and pressure test [1.10.1] are to be enclosed with the testing documentation.

1.13.2 When the steel is cast in a mill other than that where the forgings are manufactured, the Surveyor is to be supplied with a steelmaker's certificate stating the manufacturing process, the grade of steel, the cast number and the relevant ladle analysis.

2 Forgings for hull and other welded structures in general

2.1 Application

2.1.1 The requirements of this Article apply to carbon, carbon-manganese and alloy steel forgings intended for hull components, such as rudder stocks and pintles, or for hull structures, such as sternframes, rudder horns or other welded structures in general, where design and acceptance tests are related to mechanical properties at ambient temperature.

2.1.2 Forgings intended for sternframes, rudder horns, rudder stocks, pintles, tillers, anchors, anchor shackles belong to class 1; unless otherwise specified, on a case-by-case basis, other forgings belong to class 2.

2.2 Steel grades

2.2.1 The grades are identified by the symbol FC (forgings in carbon and carbon-manganese steels), followed by a

number indicating the minimum ultimate tensile strength R_m , in N/mm².

2.2.2 Where it is proposed to use alloy steels, the steel specification relevant to chemical composition, mechanical properties and heat treatment is to be submitted for approval.

2.2.3 Limits for mechanical properties of materials for rudder stock are given in Pt B, Ch 2, Sec 1 for forgings intended for rudder stocks, pintles, rudder coupling keys and bolts.

2.3 Condition of supply

2.3.1 The forgings are to be supplied in one of the following conditions, as required (see [1.9.2]):

- a) Carbon and C-Mn steel forgings
 - fully annealed
 - normalised
 - normalised and tempered
 - quenched and tempered
- b) Alloy steels forgings
 - quenched and tempered.

For all types of steel the tempering temperature is to be not less than 550°C.

Alternatively, alloy steel forgings may be supplied in the normalised and tempered condition, in which case the specified mechanical properties are to be agreed with *Tasneef*

2.4 Chemical composition

2.4.1 All forgings are to be made from killed or killed and fine grained steel, as required, and their chemical composition is to comply with the limits indicated in Tab 1 or, where applicable, the requirements of the approved specification.

The chemical composition is to be appropriate for the type of steel, dimensions and required mechanical properties of the forgings.

Forgings intended for welded construction may be required by *Tasneef* to be made from fine grained steel.

The chemical composition of each heat is to be determined by the Manufacturer on a sample taken preferably during the pouring of the heat. When multiple heats are tapped into a common ladle, the ladle analysis is to apply.

2.5 Mechanical properties

2.5.1 The requirements for the yield stress, elongation and reduction of area are given, for the different strength levels, in Tab 2.

2.6 Mechanical tests

2.6.1 In the case of individual testing [1.11.2], at least one test sample is to be taken for the required tests from the end of each forging.

Where a forging exceeds both 4 t in mass and 3 m in length, one test sample is to be taken from each end (these limits

refer to the as forged mass and length but exclude the test material).

2.6.2 In the case of batch testing, the number of test samples is indicated in [1.11.3].

2.6.3 The test specimens for 1 tensile and, when required, 3 Charpy V-notch impact tests are to be taken from each test sample.

The test specimens are to be cut in a longitudinal direction. At the discretion of the Manufacturer, the alternative directions shown in Fig 1, Fig 2 and Fig 3 may be used.

2.6.4 For forgings operating at 0°C or lower temperature, which are not dealt with in this Article, the applicable requirements are stipulated on a case-by-case basis, depending on the design temperature, application and dimensions; see also Article [8]. Forgings intended for the structure of the prop are to be made of fine grained steel and impact tested on longitudinal Charpy V-notch specimens.

The impact energy is to be not lower than 27 J at 0°C.

Forgings intended for the rudder stock and pintles of ships with ice class notation are to be made of fine grained steel and impact tested on Charpy V-notch longitudinal specimens. The impact energy is to be not lower than 27 J at -20°C.

2.7 Non-destructive examination

2.7.1 An ultrasonic examination and magnetic particle inspection are to be carried out on class 1 forgings, when required by the construction Rules of the finished products, by the approved plans or, in specific cases, by the Surveyor.

3 Forgings for machinery, shafts and equipment

3.1 Application

3.1.1 The requirements of this Article apply to carbon, carbon-manganese and alloy steel forgings, intended for use in the construction of machinery, shafts and equipment and/or not specifically dealt with in the other Articles of this Section and where design and acceptance tests are related to mechanical properties at ambient temperature.

Specific requirements for anchors are given in Ch 4, Sec 1, [1].

3.1.2 Forgings intended for propeller shafts, intermediate and thrust shafts, hubs, piston rods, connecting rods, cross heads belong to class 1; unless otherwise specified on a case-by-case basis, other forgings belong to class 2.

3.2 Steel grades

3.2.1 The grades are identified by one of the symbols FC (forgings in carbon and carbon-manganese steels) or FA (forgings in alloy steels), followed by a number indicating the specified minimum tensile strength R_m in N/mm².

3.2.2 Limits on the specified mechanical properties are given in Pt C, Ch 1, Sec 5 for forgings intended for main propulsion shafting.

3.3 Condition of supply

3.3.1 The forgings are to be supplied in one of the following conditions, as required (see [1.9.2]):

- a) Carbon and C-Mn steel forgings
 - fully annealed
 - normalised
 - normalised and tempered
 - quenched and tempered
- b) Alloy steels forgings
 - quenched and tempered.

For all types of steel the tempering temperature is to be not less than 550°C.

Alternatively, alloy steel forgings may be supplied in the normalised and tempered condition, in which case the specified mechanical properties are to be agreed with *Tasneef*

Where the specified minimum tensile strength exceed 700 N/mm², forgings in carbon manganese steel are to be supplied in the quenched and tempered condition only.

3.4 Chemical composition

3.4.1 General

All forgings are to be made from killed or killed and fine grained steel, as required, and their chemical composition is to comply with the limits indicated in Tab 3 or, where applicable, the requirements of the approved specification.

The chemical composition is to be appropriate for the type of steel, dimensions and required mechanical properties of the forgings.

Forgings intended for welded construction may be required by *Tasneef* to be made from fine grained steel.

The chemical composition of each heat is to be determined by the Manufacturer on a sample taken preferably during the pouring of the heat. When multiple heats are tapped into a common ladle, the ladle analysis is to apply.

3.5 Mechanical properties

3.5.1 The requirements for the yield stress, elongation and impact energy are given, for the different strength levels, in Tab 4.

3.6 Mechanical tests

3.6.1 In the case of individual testing [1.11.2], at least one test sample is to be taken for the required tests from the end of each forging.

Where a forging exceeds both 4 t in mass and 3 m in length, one test sample is to be taken from each end (these limits refer to the as forged mass and length but exclude the test material).

3.6.2 In the case of batch testing, the number of test samples is indicated in [1.11.3].

3.6.3 The test specimens for 1 tensile and, when required, 3 Charpy V- notch impact tests are to be taken from each test sample in accordance with Fig 1, Fig 2 and Fig 3.

The specimens are to be taken in a longitudinal direction (position A). At the discretion of the Manufacturer, the alternative directions or positions B, C and D may be used.

Figure 1 : Plain shaft

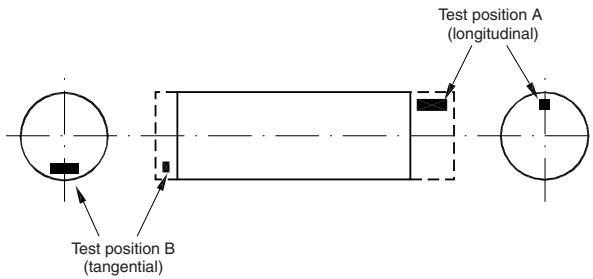

Figure 2 : Flanged shaft

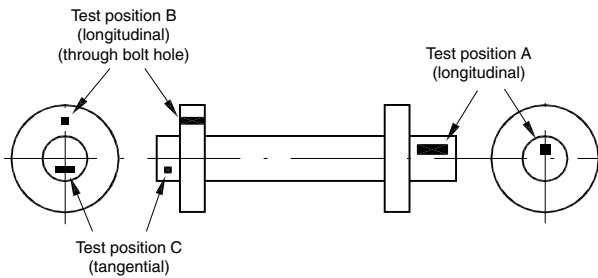
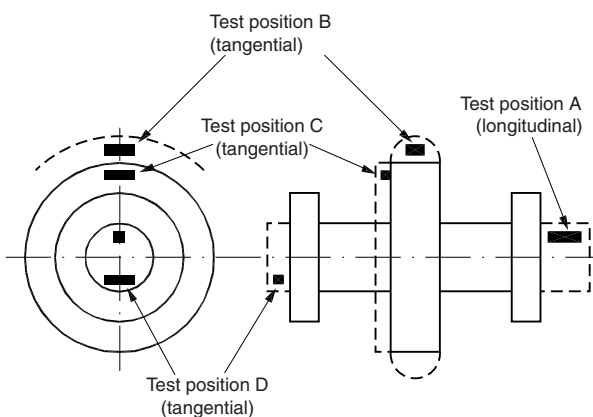

Figure 3 : Flanged shaft with collar



3.6.4

For forgings operating at 0°C or lower temperature, the applicable requirements are to be stipulated on a case-by-case basis, depending on the design temperature, application and dimensions. See also Article [8].

Forgings intended for propeller shafts of ships with ice class notation are to be made of killed or killed and fine grained steel, as required, and the average impact energy is to be

not lower than 27 J at the following temperatures for the different notations:

- a) 0°C for ships with notations IC
- b) -10°C for ships with notations IAS, IA or IB.

3.7 Non-destructive examination

3.7.1 A magnetic particle or liquid penetrant examination is to be carried out on forgings intended for:

- a) rudder stocks and pintles with diameter not lower than 100 mm
- b) main propulsion shafting with diameter not lower than 100 mm
- c) connecting rods
- d) components for engines having bore diameter larger than 400 mm, such as:
 - cylinder covers, piston crowns, piston rods, tie rods, gear wheels for camshaft drives
 - bolts and studs for cylinder covers, cross heads, main bearing and connecting rod bearings, nuts for tie rods.

Magnetic particle or liquid penetrant tests are to be carried out in positions mutually agreed upon by the Manufacturer and the Surveyor, where experience shows defects are most likely to occur.

The magnetic particle test of tie rods/stay bolts is to be carried out at each threaded portion which is at least twice the length of the thread.

3.7.2 Ultrasonic testing is to be carried out on the following items:

- a) rudder stocks and pintles with diameter not lower than 200 mm
- b) shafts having a finished diameter of 200 mm or larger, when intended for main propulsion or other essential services
- c) piston crowns and cylinders covers
- d) piston and connecting rods with connecting rod bearing caps, for engines having a bore diameter greater than 400 mm.

4 Forgings for crankshafts

4.1 Application

4.1.1 The requirements of this Article apply to carbon-manganese and alloy steel solid forged crankshafts and forgings to be used for the construction of semi-built or fully built crankshafts.

The general requirements, specified in Article [1], are also to be complied with, as appropriate.

4.1.2 Forgings intended for crankshafts belong to class 1.

4.2 Steel grades

4.2.1 The steel specification relevant to chemical composition, mechanical properties and heat treatment is to be submitted for approval.

4.2.2 The specified minimum tensile strength R_m is generally to be not lower than 400N/mm² and not higher than 1000N/mm², as required in Pt C, Ch 1, Sec 2, [2.1.1].

4.3 Manufacture

4.3.1 Continuous grain flow forging procedures are to be specially approved and, to this end, tests effected to demonstrate that a satisfactory structure and grain flow are obtained.

In the case of a welded crankshaft, the welding procedure is to be approved.

When the webs are obtained by flame cutting from forged or rolled flat products, the part to be removed by machining is to be not less than 8 mm from all flame-cut surfaces.

4.4 Condition of supply

4.4.1 Forgings are to be normalised and tempered or quenched and tempered depending on the approved specification.

The tempering temperature is to be not lower than 550°C.

4.4.2 Where a superficial hardening of the crankshaft forging by nitriding or by induction quenching is foreseen, full details of the proposed procedure are to be submitted as indicated in [1.9.5].

4.5 Chemical and mechanical properties

4.5.1 The chemical composition is to be in compliance with the approved specification [4.2.1].

For alloy steels which are to be nitrided, the phosphorus or sulphur content is to be not greater than 0,020%.

4.5.2 The minimum requirements for mechanical properties are indicated in Tab 4; see also [4.2.2].

4.6 Mechanical tests

4.6.1 For solid open die forged crankshafts one set of tensile test specimens is to be taken in the longitudinal direction, from the driving shaft end of each forging (test position A in Fig 4).

Where the mass (as heat treated but excluding test material) exceeds 3 t, the specimens in a longitudinal direction are to be taken from each end (test positions A and B in Fig 4).

Where the crank throws are formed by machining or flame cutting, the second set of specimens is to be taken in the tangential direction from material removed from the crank-throw at the end opposite to the driving shaft end (test position C in Fig 4).

4.6.2 For crank webs, one set of specimens is to be taken from each forging in the tangential direction (test position C in Fig 4).

4.6.3 For closed die crankshafts and crankshaft forgings where the method of manufacture has been specially approved in accordance with [4.3.1], the number and position of the specimens for mechanical tests are specified at the time of approval of the method of manufacture.

4.6.4 When small crankshaft forgings are batch tested [1.11.3], hardness tests are to be made on the individual pieces.

4.7 Non-destructive examination

4.7.1 Magnetic particle and/or liquid penetrant tests are required for all crankshaft forgings.

Where applicable, this is also to include all flame-cut surfaces not subsequently machined.

Special care is to be devoted to the pins and journals and associated fillets.

Unless otherwise agreed, all crankshaft forgings having a minimum crankpin diameter not lower than 150 mm are to be ultrasonically examined.

4.7.2 Non-destructive examination procedures and the acceptance criteria of the indications of such tests, complying with the requirements of the engine Manufacturer, are to be previously approved by *Tasneef*

5 Forgings for gearing

5.1 Application

5.1.1 The requirements of this Article apply to carbon-manganese and alloy steel forgings intended for the construction of gearing for main propulsion and auxiliary equipment.

The general requirements, specified in Article [1], are also to be complied with, as appropriate.

5.1.2 Forgings intended for pinions and gear wheels belong to class 1.

5.1.3 In the case of forgings for flexible couplings, quill shafts and gearwheel shafts, the requirements of Article [3] apply.

5.2 Steel grades

5.2.1 Steels are to comply with requirements specified in [3.2] or with a specification approved by *Tasneef*

To this end, a detailed specification relevant to chemical composition, mechanical properties and heat treatment is to be submitted for approval.

5.2.2 Limits on the specified minimum tensile strength are given in Pt C, Ch 1, Sec 4, depending on heat treatment condition.

Figure 4 : Solid forged crankshaft

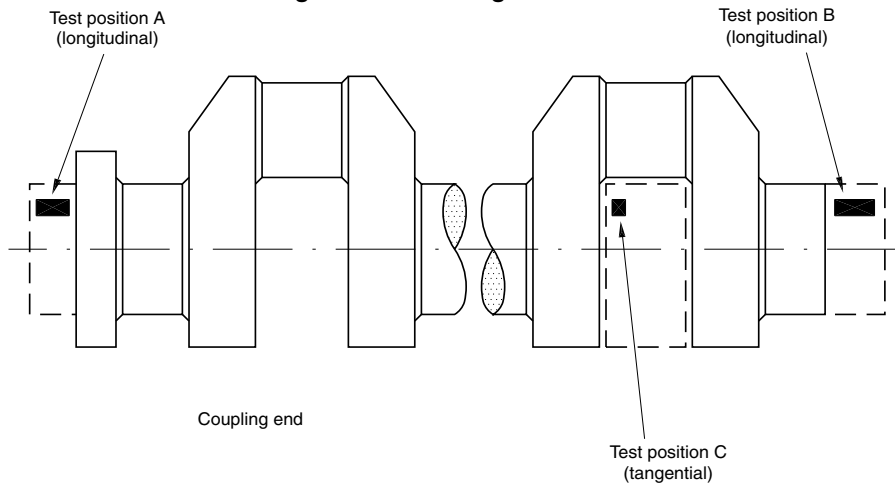

5.3 Manufacture

5.3.1 The reduction ratio during forging is to be in compliance with [1.3.2].

Forgings are to be provided on the surfaces with excess material sufficient as may be necessary for machining out possible defective zones.

5.4 Condition of supply

5.4.1 The conditions of supply are indicated in the approved specification of the product; unless otherwise specified therein, the conditions indicated in [5.4.2] apply.

5.4.2 Forgings which are not to be surface-hardened are to be normalised and tempered or quenched and tempered; the tempering temperature is allowed to be lower than 550°C.

Forgings which are to be carburised are to be in either the "fully annealed" or the "normalised and tempered" condition, suitable for the subsequent operations.

Forgings which are to be induction hardened or nitrided, in the appropriate stage of manufacture when the surface hardening is done, are to be heat treated to a condition adequate for such operations.

5.4.3 Treatments for surface hardening are to be approved in accordance with [1.9.5].

5.5 Chemical and mechanical properties

5.5.1 The chemical composition and the mechanical properties are specified in [3.4] and [3.5], respectively, or in the approved specification; see also [5.2.1].

5.6 Mechanical tests for normalised and tempered or quenched and tempered forgings

5.6.1 Sampling

The specimens necessary for the required tests are to be taken from each forging [1.11.2] or a forging representative

of the batch [1.11.3], in accordance with Fig 5, Fig 6, Fig 7 and Fig 8.

The set of test specimens is to be taken as follows:

- Pinions (see Fig 5):
Where the finished machined diameter of the toothed portion exceeds 200 mm, one set of test specimens is to be taken from each forging in the tangential direction adjacent to the toothed portion (test position B). Where the dimensions preclude the preparation of tests from this position, tests in the tangential direction are to be taken from the end of the journal (test position C).
If, however, the journal diameter is equal to or less than 200 mm, tests are to be taken in a longitudinal direction (test position A).
Where the finished length of the toothed portion exceeds 1,25 m, one set of test specimens is to be taken from each end.
Where the finished diameter of the toothed portion is equal to or less than 200 mm, one set of test specimens is to be taken in a longitudinal direction (test position A).
- Gear wheel (see Fig 6):
One set of tests is to be taken from each forging in a tangential direction (test positions A or B).
- Gear wheel rims made by expanding (see Fig 7):
One set of tests is to be taken from each forging in the tangential direction (test position A). Where the finished diameter exceeds 2,5 m or the mass (as heat treated excluding test material) exceeds 3 t, two sets of test specimens are to be taken from diametrically opposite positions (test positions A and B).
The mechanical properties for longitudinal testing are to be applied.
- Pinion sleeves (see Fig 8):
One set of test specimens is to be taken from each forging in the tangential direction (test position A). Where the finished length exceeds 1,25 m, one set of test specimens is to be taken from each end.

Figure 5 : Pinions

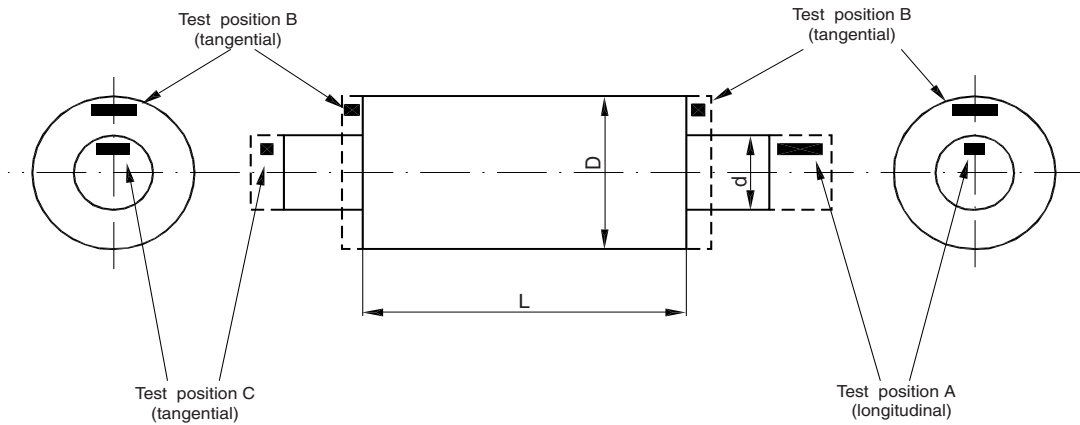

- L : length of toothed portion, in mm
 D : diameter of toothed portion, in mm
 d : journal diameter, in mm.

5.6.2 Hardness tests

Hardness tests may be required generally as verification of the homogeneity, at the discretion of the Surveyors. See also [1.11.10] a).

The hardness is to be determined after completion of heat treatment and prior to machining the gear teeth.

Measurements are to be carried out at four positions equally spaced around the circumference of the surface where teeth will subsequently be cut. Where the finished diameter of the toothed portion exceeds 2,5m, the above number of test positions is to be increased to eight.

Where the width of a gear wheel rim forging exceeds 1,25 m, the hardness is to be determined at eight positions at each end of the forging.

When small gear forgings are batch tested ([1.11.3]), hardness tests are to be made on the individual pieces.

5.7 Mechanical tests for surface-hardened forgings

5.7.1 Sampling

Forgings to be carburised are to be provided with sufficient test material for the sets of specimens for both preliminary tests at the forge and final tests after completion of carburising.

The set of specimens consists of 1 tensile test specimen.

For this purpose duplicate sets of test material are to be taken from positions as detailed in [5.6.1] except that, irrespective of the dimensions or the mass of the forging, the tests are required from one position only and, in the case of

forgings with integral journals, the material is to be cut in a longitudinal direction.

This test material is to be machined to a diameter of $D/4$ or 60 mm, whichever is the lesser, where D is the finished diameter of the toothed position.

For preliminary tests at the forge, the test material is to be given a blank carburising and heat treatment cycle, simulating the one which will be subsequently applied to the forging.

For final acceptance tests, the test material is to be blank carburised and heat treated together with the forgings which it represents.

At the discretion of the Manufacturer, test samples of larger cross-section may be either carburised or blank carburised, but they are to be machined to the required diameter prior to the final quenching and tempering treatment.

Alternative procedures for testing of forgings which are to be carburized may be specially agreed with ^{Tasneef}

Figure 6 : Gear wheel

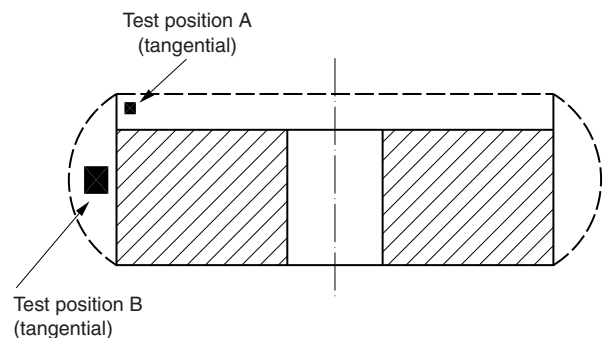

Figure 7 : Gear wheel rim made by expanding

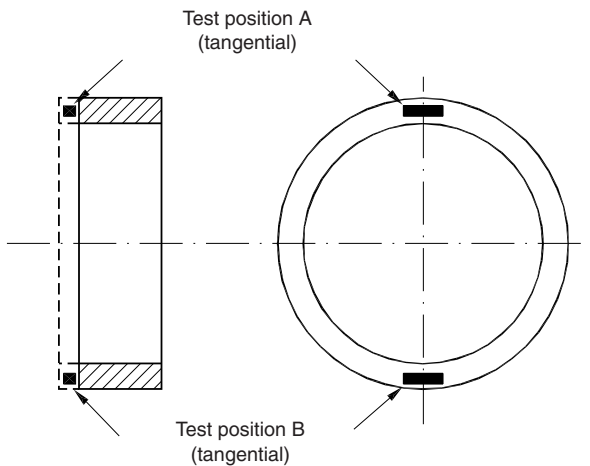
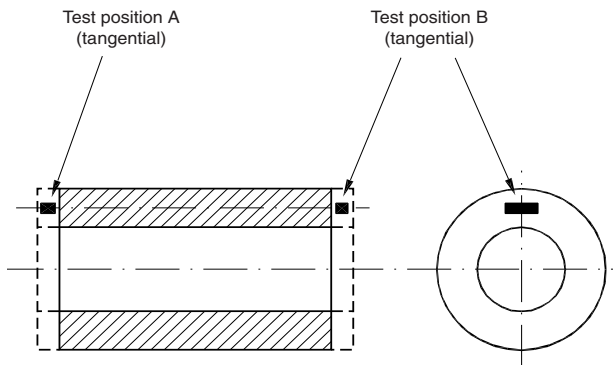

Figure 8 : Pinion sleeve



5.7.2 Hardness tests and additional checks

Hardness tests may also be required on forgings which have been induction hardened, nitrided or carburised. See also [1.11.10] b).

The hardness is to be determined on the toothed part after the teeth have been ground to the finished profile. The results of such tests are to comply with the approved specification.

Additional checks [1.11.11] of the hardness, depth and shape of the hardened layer are to be performed as indicated in the approved specification.

When, for nitrided gearing, hardness verification is required on additional test samples, unless otherwise stated in the approved specification the depth of the hardened zone is to be not lower than 0,5 mm and the hardness at a depth of 0,25 mm is to be not lower than 500 Vickers points.

5.8 Non-destructive examination

5.8.1 Magnetic particle or liquid penetrant testing is required on the tooth surfaces of gears hardened completely or at their surface.

An ultrasonic examination of the forgings is to be performed by the Manufacturer when there is still an adequate amount

of excess material on the surfaces in respect of the final position of the teeth.

In general, ultrasonic examination is required for forging having a finished diameter, of the part where teeth will be cut, higher than 200 mm.

6 Forgings for turbines

6.1 Application

6.1.1 The requirements of this Article apply to steel forgings intended for the construction of rotors and discs of main turbines and rotors of auxiliary turbines driving electric generators and compressors.

The general requirements specified in Article [1] are also to be complied with, as appropriate.

6.1.2 Forgings intended for propulsion machinery or essential auxiliary systems belong to class 1.

6.1.3 Plans submitted for approval are to state whether the turbine is for propulsion or for auxiliary service; in the latter case the shaft power is to be specified.

For rotors to be subjected to a thermal stability test, the maximum service temperature and the proposed test temperature are also to be specified.

For rotors of welded construction, the chemical composition of the steel is to be approved.

6.2 Steel grades, chemical composition and mechanical properties

6.2.1 The steel grades and relevant properties may be in accordance with [3.2], [3.4] and [3.5] or with a particular specification to be submitted for acceptance.

6.3 Condition of supply

6.3.1 The intermediate and final heat treatments, specified by the Manufacturer, are to be submitted for consideration.

In particular, the heat treatments are to be such as to avoid hair-line cracks.

For rotors of welded construction, the heat treatment is to be specially approved.

6.4 Mechanical tests

6.4.1

For rotors not exceeding 3 t in mass, one set of longitudinal tensile specimen is to be taken from one end of the shaft and one set of test specimen is to be taken in the tangential direction from the body portion (see Fig 9).

For rotors exceeding 3 t in mass, the set of longitudinal specimens is to be taken from each end of the shaft and the set of tangential test specimens is to be taken from the body portion (see Fig 9).

For each turbine disc, at least one set of specimens is to be taken from the boss in the tangential direction (see Fig 10).

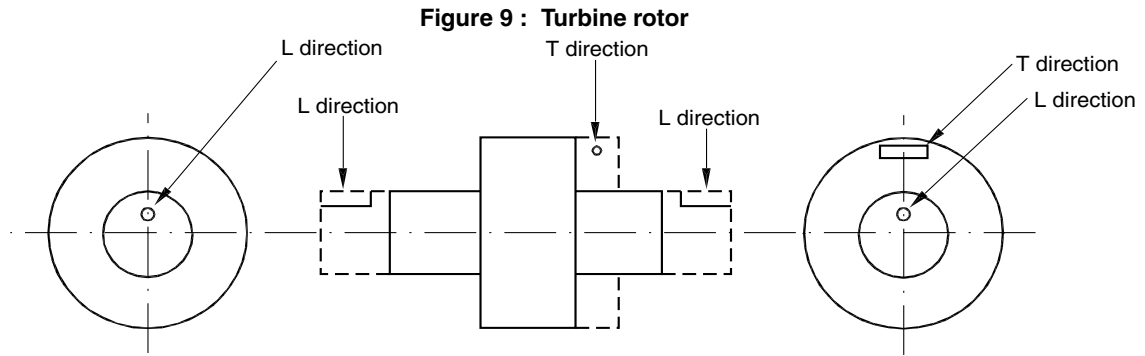
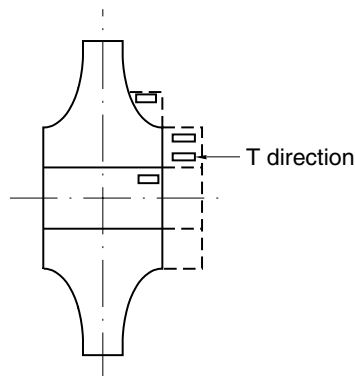

Figure 10 : Turbine disc



6.5 Non-destructive examination

6.5.1 A visual examination, supported by a magnetic particle examination at the discretion of the Surveyor, is required for the end surfaces of the rotors and the boss of the discs; the degree of finishing is to be appropriate for this purpose. An ultrasonic examination is to be carried out by the Manufacturer on all forgings.

6.5.2 Rotor forgings for propulsion turbines having a power exceeding 1100 kW are to be hollow bored to permit internal examination visually and, where possible, by the magnetic particle method.

These examinations are to be confirmed by the Surveyor; the degree of finishing is to be adequate for the purpose.

At the discretion of ^{Tasneef} ultrasonic examination of the rotor by an approved procedure may be accepted as an alternative to hollow boring.

6.6 Thermal stability test

6.6.1 Solid forged rotors and rotors built by welding two or more forged pieces and intended for turbines having a service temperature exceeding 400°C are to be subjected, after the final heat treatment and in their rough machined condition, to a thermal stability test.

The test is to be performed using procedures and equipment to the satisfaction of ^{Tasneef}

The deflection may be measured with the procedure outlined below, which consists in reading the radial elongation in way of some machined zones distributed along the length of the rotor (in general, there will be two reference machined zones in way, or in proximity, of the supports and

three test machined zones located one at the mid-length and two at the ends of the rotor).

Four markings, 90° apart, are to be stamped for identification on the coupling end of the rotor.

During the test, the rotor is to be rotated very slowly and uniformly in the furnace, while it is heated gradually and evenly, excessive thermal gradients being avoided; the rotor is to be maintained for a sufficient length of time at the specified test temperature, which is to be appropriate to the final heat treatment of the piece, and subsequently slowly and uniformly cooled to a sufficiently low temperature, excessive thermal gradients again being avoided.

In the course of the test, the deflections are to be regularly recorded in each machined zone, at angular intervals of 90°, and the difference in the readings between the cold and hot conditions is not to exceed the specified limits.

In general, the following requirements are to be complied with:

- the furnace is to be large enough to contain the whole length of the rotor, including the end zones in way of the glands; overhung wheels, when present, are also to be enclosed in the furnace
- means are to be provided for continuous recording of the temperature at the surface of the rotor and, if practicable, in a bore at the mid-length of the rotor
- the temperature of the rotor is in no case to exceed the final tempering temperature
- the test temperature is to not be less than the maximum service temperature +28°C but not higher than the temperature mentioned above; the temperature distribution is to be uniform and maintained at a constant level for at least three hours with the readings falling within 0,006 mm in all the machined zones
- the rotor is to be rotated during cooling until the temperature is not more than 100°C
- cold readings are to be taken before and after the test.

The test results are considered satisfactory when the difference between the final readings in the hot conditions and the initial and final cold readings do not exceed 0,025 mm in any zone.

Otherwise, at the request of the Manufacturer and with ^{Tasneef} approval, the test may be repeated; when the results of the second test are also unsatisfactory, proposals for alterations to the rotor are to be approved by ^{Tasneef} before further testing.

7 Forgings for boilers, pressure vessels and systems

7.1 Application

7.1.1 The requirements of this Article apply to weldable forgings made from carbon, carbon-manganese, molybdenum and chromium-molybdenum low alloy steels, intended for the construction of boilers and pressure vessels, plants and piping systems in general, when impact properties at temperature not lower than -20°C are specified.

For forgings not subjected to welding, the requirements of Article [2] apply, as appropriate.

7.1.2 Forgings intended for pressure vessels and piping systems of class 1, as defined in Part C, belong to class 1. Unless otherwise required on a case-by-case basis, the other forgings belong to class 2.

7.1.3 Forgings intended for vessels and systems operating at low temperatures are to comply with the applicable requirements of Article [8] and, in the case of applications involving the storage and transport of liquefied gases, with those specified in Pt E, Ch 1, Sec 14.

7.2 Steel grades

7.2.1 Carbon and carbon-manganese steels are classed into three groups indicating the minimum ultimate tensile strength R_m , in N/mm²: 410, 460 and 510.

Each group may be further subdivided into grades HA, HB and HD, based on conventional levels of quality and impact properties.

7.2.2 Low alloy steels are designated according to the chemical composition in the grades 0,3Mo-1Cr0,5Mo-2,25Cr1Mo.

The figures mean the nominal percentage content of the main alloying elements.

Where it is proposed to use steels other than those dealt with in these Rules, the steel specification relevant to chemical composition, mechanical properties and heat treatment is to be submitted for approval.

7.3 Condition of supply

7.3.1 Forgings are to be supplied in one of the following conditions, as required by the steel specification (see [1.9.2]):

- a) carbon and carbon-manganese steels:
 - normalised
 - normalised and tempered
 - quenched and tempered
- b) alloy steels:
 - normalised and tempered
 - quenched and tempered.

For all types of steel the tempering temperature is to be not lower than 550°C.

7.4 Chemical composition

7.4.1 The chemical composition on ladle analysis is to comply with the limits specified in Tab 5 for carbon and carbon-manganese forgings and Tab 6 for Cr and Cr-Mo alloy steel forgings.

7.5 Mechanical properties

7.5.1 The mechanical properties are specified in Tab 7 for carbon and carbon-manganese steel and in Tab 8 for Cr and Cr-Mo alloy steel forgings.

7.6 Mechanical properties at elevated temperature

7.6.1 The values for the 0,2% proof stress ($R_{p0,2}$) at temperatures of 150°C and higher are given in Tab 9.

The above values are for design purposes only. Their verification is in general not required during the testing, unless figures higher than those shown in Tab 9 and in accordance with recognised standards are proposed by the steel Manufacturer.

In such cases, the verification is required and the procedures detailed in [7.6.2] and [7.6.3] are to be followed.

7.6.2 When $R_{p0,2}$ is required to be verified, at least one tensile test for each cast is to be carried out at the agreed temperature on each forging or batch of forgings.

The test specimen is to be taken near the position of the tensile specimen tested at ambient temperature.

The dimensions of the specimens and the testing procedure are to be in accordance with the requirements of Ch 1, Sec 2, [2.1] and Ch 1, Sec 2, [2.2.5], respectively.

The results of tests are to comply with the specified values.

7.6.3 As an alternative to the systematic verification of the required $R_{p0,2}$ as in [7.6.2], it may be agreed with the individual steelmakers to carry out an adequate program of tests or to adequately check the statistical data of the current production.

7.6.4 The values of the estimated average stress to rupture in 100.000 hours are given, for design purposes only, in Sec 1, Tab 19.

7.7 Mechanical tests

7.7.1 With the exception of drums (see [7.7.2]), at least one set of specimens for mechanical tests (1 tension and unless otherwise required 3 Charpy V-notch specimens for type HB and HD) is to be taken from each forging [1.11.2] or batch [1.11.3]; unless otherwise agreed and when possible, specimens are to be taken in the longitudinal direction.

7.7.2 For drum forgings, one set of specimens for mechanical tests is to be taken from each open end.

When, depending on the manufacturing procedure, the test samples are to be detached before heat treatment, they are to be heat treated with the forging they represent.

The specimens are to be cut in the circumferential direction. Where the tensile test is carried out on specimens taken at both ends of a drum forging, the variation in tensile strength R_m on the two tests is not to exceed 70 N/mm².

7.7.3 For tensile tests at elevated temperatures, the requirements of [7.6.2] apply.

7.8 Non-destructive examination

7.8.1 Unless otherwise required or agreed, at least the following non-destructive examinations are to be carried out:

- all class 1 forgings are to be examined by the magnetic particle method
- all class 1 drum forgings and other similar important forgings having thickness higher than 10 mm are to be examined by ultrasonic method.

8 Ferritic steel forgings for low temperature service

8.1 Application

8.1.1 The requirements of this Article apply to ferritic steel forgings intended for welded structural use as in the construction of structures, vessels, plants and piping systems for low temperature service or when, irrespective of the service conditions, they are required to satisfy specified impact properties at temperatures lower than -20°C.

8.1.2 Unless otherwise agreed, forgings covered by this Article belong to class 1.

8.1.3 In the case of applications involving the storage and transport of liquefied gases or fluids at low temperature in general, the appropriate requirements of Pt E, Ch 1, Sec 14 also apply.

8.2 Steel grades and relevant properties

8.2.1 The requirements apply to carbon, carbon-manganese and nickel alloy steels.

The steel specification relevant to chemical composition, mechanical properties and heat treatment is to be submitted for approval.

Reference can be made to the steel designation, chemical composition and mechanical properties relevant to the rolled materials to which the forgings are intended to be welded, i.e. in particular, for these Rules, to Sec 1, Tab 20 and Sec 1, Tab 22 for carbon and carbon-manganese steels, and to Sec 1, Tab 21 and Sec 1, Tab 23 for nickel alloy steels.

8.3 Condition of supply

8.3.1 Forgings are to be normalised, normalised and tempered or quenched and tempered, depending on the grade of steel, as indicated in Sec 1, [5.4.1] or in the approved specification.

8.4 Mechanical tests

8.4.1 At least one set of specimens for mechanical tests (1 tensile and 3 Charpy V-notch specimens) is to be taken from each forging [1.11.2] or batch [1.11.3]; unless otherwise agreed and when possible, specimens are to be cut in the longitudinal direction.

The impact tests are generally to be carried out at the minimum temperature stated for the type of steel; a higher test temperature may be agreed with *Tasneef* however, depending on the design service temperature of the individual applications.

8.5 Non-destructive examination

8.5.1 Unless otherwise required or agreed, class 1 forgings are to be examined by the magnetic particle method.

When the above forgings have thickness higher than 10mm, they are also to be subjected to ultrasonic examination.

9 Stainless steel forgings

9.1 Application

9.1.1 The requirements of this Article apply to stainless steel forgings intended for construction of cargo and storage tanks, pressure vessels, and piping fittings for chemical and/or low temperature applications.

9.1.2 Unless otherwise specified or agreed, the forgings covered by this Article belong to class 1.

9.1.3 Austenitic stainless steels are suitable for use at both elevated and low temperatures where the design temperature is not lower than -165°C.

When austenitic stainless steels are proposed for use at elevated temperatures, details of chemical composition, mechanical properties and heat treatment are to be submitted for consideration and approval.

9.1.4 Stainless steels may also be used for shafts and machinery applications under Article [3].

9.1.5 In the case of applications involving the storage and transport of liquefied gases or fluids at low temperature in general, the appropriate requirements of Pt E, Ch 1, Sec 14 also apply.

9.2 Steel grades and relevant properties

9.2.1 The requirements apply to austenitic Cr-Ni steels.

The general requirements relevant to designation, chemical composition, mechanical properties and condition of supply are specified in Sec 1, [7] relevant to rolled products.

9.2.2 Other types of stainless steels (ferritic-austenitic or martensitic), complying with international or national specifications, may be accepted for particular applications (e.g. [9.1.4]); their relevant specification is to be submitted for approval.

Table 1 : Chemical composition limits for hull steel forgings

Steel type	C	Si	Mn	P	S	Cr	Mo	Ni	Cu (3)	Total residuals
C, C - Mn	0,23 (1) (2)	0,45	0,30 1,50	0,035	0,035	0,30 (3)	0,15 (3)	0,40 (3)	0,30	0,85
Alloy	(4)	0,45	(4)	0,035	0,035	(4)	(4)	(4)	0,30	

Note 1: Composition in percentage mass by mass maximum unless shown as a range.
Note 2: Rudder stocks and pintles are to be of weldable quality.
Note 3: At the discretion of the Manufacturer or the request of ^{Tasneef} suitable grain refining elements such as aluminium, niobium or vanadium may be added. The content of such elements is to be reported.
(1) The carbon content may be increased above this level provided that the carbon equivalent (Ceq) is not more than 0,41%, calculated using the following formula:

$$Ceq = C + \frac{Mn}{6} + \frac{Cr + Mo + V}{5} + \frac{Ni + Cu}{15} (\%)$$

(2) The carbon content of C and C-Mn steel forgings not intended for welded construction may be 0,65 maximum.
(3) Elements are considered as residual elements.
These elements are not to be intentionally added to the steel and their content is to be reported.
(4) Specification is to be submitted for approval.

9.3 Mechanical tests

9.3.1 Sampling and mechanical tests are to be in compliance with the requirements of [3.6] and [7.7], as appropriate, depending on the application (machinery or pressure systems).

Unless otherwise required, impact tests on the austenitic grades are to be performed for a service temperature lower than -105°C and are to be carried out at -196°C.

The results of the tests are to be in accordance with the requirements of Sec 1, [7.6.1].

9.4 Non-destructive examination

9.4.1 Unless otherwise required or agreed, class 1 forgings are to be examined by the liquid penetrant test and/or by the ultrasonic method, as appropriate, depending on the application.

9.5 Corrosion tests

9.5.1 For forgings intended for chemicals, the corrosion tests, ASTM A262 Practice E (copper- copper sulphate sulphuric) or ASTM A262 Practice C (nitric acid test), as appropriate, may be required to be carried out on one piece per batch.

Tests in accordance with other recognised standards may be accepted subject to the agreement of ^{Tasneef}

Table 2 : Mechanical properties for hull steel forgings

Steel type (1)	Tensile strength (2) R _m min. N/mm ²	Yield stress R _e min. N/m ²	Elongation A ₅ min. %		Reduction of area Z min. %	
			Long.	Tang.	Long.	Tang.
C and C - Mn	400	200	26	19	50	35
	440	220	24	18	50	35
	480	240	22	16	45	30
	520	260	21	15	45	30
	560	280	20	14	40	27
	600	300	18	13	40	27
Alloy	550	350	20	14	50	35
	600	400	18	13	50	35
	650	450	17	12	50	35

(1) For forgings intended for rudder stock and pintles of ships with ICE Class Notation see [2.6.4].
(2) Unless otherwise agreed, the tensile strength is not to exceed the specified value by more than 120 N/mm² for R_m < 600 N/mm² or 160 N/mm² for R_m ≥ 600 N/mm²

Table 5 : Carbon and carbon-manganese steels - Chemical composition

Steel grade	Deoxidation	Chemical composition (%) (1)						
		C max	Mn	Si	P max	S max	Al tot. min. (1)	Ni max
410 HA	killed	0,20	0,60 - 1,40	0,10 - 0,40	0,030	0,030		0,40
410 HB	killed							
410 HD	killed and fine grained						0,020	
460 HA	killed	0,22	0,90 - 1,60	0,10 - 0,50	0,030	0,030		0,40
460 HB	killed							
460 HD	killed and fine grained	0,20					0,020	
510 HA	killed	0,23	1,00 - 1,60	0,10 - 0,50	0,030	0,030		0,40
510 HB	killed							
510 HD	killed and fine grained						0,20	

(1) Nb, V or Ti may be used for grain refining as a complete or partial substitute for Al, in which case the minimum value for Al content does not apply. The grain refining elements are to be specified at the time of approval; in general Nb and V are not to exceed 0,05% and 0,10%, respectively. Additional alloying elements are to be submitted for consideration and approval. Residual elements not intentionally added are not to exceed the following limits: Cu ≤ 0,30%; Cr ≤ 0,25%; Mo ≤ 0,10%. Total: Ni + Cu + Cr + Mo ≤ 0,80%

Table 6 : Low alloy steels - Chemical composition

Steel grade	Deoxidation (2)	Chemical composition (%) (1)						
		C	Mn	Si	P max	S max	Cr	Mo
0,3Mo	Si killed	0,12 - 0,22	0,40 - 0,90	0,10 - 0,40	0,030	0,030	-	0,25 - 0,35
1Cr 0,5Mo	Si killed	≤ 0,18	0,40 - 1,70	0,10 - 0,40	0,030	0,030	0,80 - 1,15	0,40 - 0,65
2,25Cr 1Mo	Si killed	≤ 0,15	0,10 - 0,40	0,10 - 0,40	0,030	0,030	2,00 - 2,50	0,90 - 1,10

(1) Residual elements are not to exceed the following limits: Cu ≤ 0,30%; Ni ≤ 0,30%.
(2) The aluminum total is to be lower than 0,020% for all grades of steel. The aluminum content is to be mentioned on the ladle analysis certificate.

Table 7 : Carbon and carbon-manganese steels - Mechanical properties

Steel grade	Yield stress R _{eH} (N/mm ²) min. for thickness t (mm)		Tensile strength R _m (N/mm ²)	Elongation A ₅ (%) min. for thickness t (mm) (1)				Average impact energy (J) min.				
	t ≤ 100	100 < t ≤ 250		t ≤ 100		100 < t ≤ 250		Test temp (°C)	KVL	KVT		
				L	T	L	T					
410 HA	230	220	410 - 530	24	23	23	21	+ 20	41	27		
410 HB								0			27	22
410 HD								- 20				
460 HA	260	250	460 - 600	23	21	22	20	+ 20	27	22		
460 HB								0				
460 HD								280			260	- 20
510 HA	280	270	510 - 650	21	20	20	19	+ 20	41	27		
510 HB								0				
510 HD								330			310	- 20

(1) L and T stand for longitudinal and tangential specimens, respectively.

Table 8 : Low alloy steels - Mechanical properties

Steel grade	Yield stress R_{eH} (N/mm ²) min. for thickness t (mm) (1)		Tensile strength R_m (N/mm ²)	Elongation A_5 (%) min. (2)		Average impact energy (J) min.		
	$t \leq 100$	$100 < t \leq 250$		L	T	Test temp (°C)	KVL	KVT
0,3Mo	285	270	440 - 570	23	21	+20	50	34
1Cr 0,5Mo	270	255	440 - 590	20	18		44	27
2,25Cr 1Mo	275	275	500 - 650	19	17		60	50
(1) For thickness or diameter greater than 250 mm, values are to be agreed with Tasneef								
(2) L and T stand for longitudinal and tangential specimens, respectively.								

Table 9 : Minimum proof stress ($R_{p0,2}$) values at elevated temperatures

Steel grade	Thickness (mm)	$R_{p0,2}$ (N/mm ²) at a temperature (°C) of							
		150	200	250	300	350	400	450	500
410 HA (1)	≤ 100	190	180	170	150	140	135	135	
410 HB (1)	> 100	175	170	160	150	140	135	135	
410 HD (1)	≤ 100	205	190	170	150	140	135	130	
	> 100	190	175	165	150	140	135	130	
460 HA (1)	≤ 100	215	210	195	175	170	160	155	
460 HB (1)	> 100	200	200	190	-	-	-	-	
460 HD (1)	≤ 100	235	215	200	175	165	155	150	
	> 100	220	200	190	175	-	-	-	
510 HB (1)	≤ 100	235	225	210	190	180	175	170	
	> 100	220	210	200	190	-	-	-	
510 HD (1)	≤ 100	255	235	215	190	180	170	165	
	> 100	240	215	205	190	-	-	-	
0,3Mo			200	185	170	160	150	140	130
1Cr 0,5Mo			210	200	180	170	160	150	140
2,25Cr 1Mo			240	230	220	210	200	190	180
(1) The values at $R_{p0,2}$ for temperatures $\leq 250^\circ\text{C}$ are for guidance only.									

SECTION 4

STEEL CASTINGS

1 General

1.1 Application

1.1.1 General

The requirements of this Section apply to steel castings intended for hull, structural applications, machinery, boilers, pressure vessels and piping systems.

These requirements are applicable only to steel castings where the design and acceptance tests are related to mechanical properties at ambient temperature. For other applications, additional requirements may be necessary, especially when the castings are intended for service at low or elevated temperatures.

This Article specifies the requirements common to all the above-mentioned steel products, while the specific requirements for the various applications are indicated in Articles [2] to [7].

Alternatively, castings which comply with national or proprietary specifications may be accepted provided such specifications give reasonable equivalence to these requirements or are otherwise specially approved or required by ^{Tasneef}

1.1.2 Mass productions

For mass produced small castings, the Manufacturer may adopt particular procedures for testing and inspection subject to the approval of ^{Tasneef}

1.1.3 Special requirements

Special requirements may be specified in the case of applications intended for dangerous substances or for particularly severe service conditions.

In the case of applications involving the storage and transport of liquefied gases or fluids at low temperature in general, the appropriate requirements of Pt E, Ch 1, Sec 14 also apply.

1.2 Classification of castings

1.2.1 For the purposes of this Section, castings are divided into two Classes depending on their service:

- a) class 1 castings are those intended for important applications, such as propellers, components of crankshafts, engine bedplates, cylinder and piston heads, rudder stocks, anchors, other important components of hull and machinery, components under pressure relative to class 1 pressure systems, cargo gear items subjected to severe stresses, etc. The castings indicated in [1.1.3] also pertain to class 1.
- b) class 2 castings are all those subject to testing and not included in class 1.

1.3 Manufacture

1.3.1 Manufacturing process

The steel is to be manufactured as detailed in Sec 1, [1.2.1].

1.3.2 Flame and arc-air shaping

All flame cutting, scarfing or arc-air gouging to remove surplus metal is to be undertaken in accordance with recognised good practice and, unless otherwise accepted, is to be carried out before the final heat treatment. Preheating is to be employed when necessitated by the composition and/or thickness of the casting. For certain components, subsequent machining of all flame cut surfaces may be required.

1.3.3 Welding of castings

When two or more castings are joined by welding to form a composite component, the proposed welding procedure is to be submitted for approval. Welding procedure qualification tests may be required.

1.4 Approval

1.4.1 Class 1 castings are to be made by a Manufacturer approved by ^{Tasneef}

When the approval is not required, the Manufacturers are in any event to be recognised on a case-by-case basis.

Provisions for the approval are given in the "Rules for the approval of Manufacturers of materials".

For certain components including steel casting subjected to surface hardening process, the proposed method of manufacture may require special approval by ^{Tasneef}

1.5 Quality of materials

1.5.1 All castings are to be free from surface or internal defects which would be prejudicial to their proper application in service.

The surface finish is to be in accordance with good practice and with any specific requirements of the approved plans or purchase order.

1.6 Visual and dimensional examination

1.6.1 Visual examination

All castings are to be cleaned and adequately prepared for examination; suitable methods include pickling, caustic cleaning, wire brushing, local grinding, and shot or sand blasting.

The surfaces are not to be hammered or treated in any way which may obscure defects; procedures of this kind may cause rejection of the piece.

All products are to be submitted by the Manufacturer to visual examination; where applicable, this is to include the examination of internal surfaces and bore.

All class 1 castings are also to be presented to the Surveyor for visual examination.

Unless otherwise specified, the visual examination of class 2 castings by the Surveyor is not required.

1.6.2 Verification of dimensions

The verification of dimensions and tolerances is the responsibility of the Manufacturer.

Checks of dimensions for verification of compliance with the approved plans are, in general, required for important castings, to the Surveyor's satisfaction.

1.7 Non-destructive examination

1.7.1 General

When required by the applicable Parts of the Rules, the approved plans, the approved procedures for welded composite components or, in specific cases, the Surveyor, appropriate non-destructive tests are to be carried out and the results reported by the Manufacturer.

All such tests are to be carried out by competent operators qualified according to the requirements of Ch 1, Sec 1, [3.6.4], using reliable and efficiently maintained equipment. The testing procedures, the extent of testing and the acceptance criteria are to be in accordance with the applicable Rules and any specific requirements of the approved plans, to the Surveyor's satisfaction.

IACS Recommendation No. 69 is regarded as an example of an acceptable standard.

The Manufacturer is to provide the Surveyor with a report confirming that the required examinations have been carried out without revealing significant defects; details of the procedure used are also to be indicated in the report.

1.7.2 Magnetic and liquid penetrant examination

A magnetic particle or liquid penetrant examination is to be carried out when the castings are in the finished condition.

Where current flow methods are used for magnetisation, particular care is to be taken to avoid damaging finished machined surfaces by contact burns from the prods.

Unless otherwise agreed, these tests are to be carried out in the presence of the Surveyor.

1.7.3 Radiographic examination

Radiographic examination is to be carried out by the Manufacturer at positions as indicated on the approved plans and, at least for class 1 castings, in areas deemed susceptible to casting defects; welded joints and adjacent zones are also to be checked.

All radiographs are to be submitted to the Surveyor for acceptance.

1.7.4 Ultrasonic examination

Ultrasonic examination is to be carried out following the final heat treatment at positions as indicated in [1.7.3].

Unless otherwise required, this examination is to be carried out by the Manufacturer but Surveyors may request to be present, in particular in order to verify that the examination is carried out in accordance with the agreed procedure.

1.8 Rectification of defects

1.8.1 Where defective steel castings are to be rectified by grinding or other suitable means, with or without subsequent weld repair, the prior approval of ^{Tasneef} is to be obtained.

1.8.2 Rectification of defects by grinding

Defects and unacceptable imperfections may be removed by machining or chipping. Flame-scarfing or arc-air gouging may also be used provided that preheating is employed when necessary and that the surfaces of the resulting depression are subsequently ground smooth.

Complete elimination of the defective material is to be proved by a magnetic particle or liquid penetrant examination.

At the discretion of the Surveyor, the resulting shallow grooves or depressions may be accepted provided that they will cause no appreciable reduction in the strength of the castings and that they are suitably smoothed and contoured by grinding.

Where the presence of surface defects may reasonably raise doubts as to the internal soundness of a casting, additional examinations may be required, at the discretion of the Surveyor, both on the casting itself and, if necessary, on other castings of the same presentation cast with the same procedure.

1.8.3 Rectification of defects by welding

Proposals to repair a defective casting by welding are to be submitted to the Surveyor for approval before this work is commenced.

Such proposals are to include details of the position and extent of all defects, the repair procedure, the heat treatment, if any, and subsequent inspection procedures.

For the purpose of the acceptance of the proposed repairs, due consideration is to be given to the type, class and service conditions of the casting.

When accepted, welding is to be carried out in accordance with an approved welding procedure, as required; see also [1.8.4].

A report (possibly with a sketch) detailing the above information as to the extent and location of all repairs, welding procedure, post-weld heat treatment, non-destructive examinations, results, etc. is to be prepared by the Manufacturer; this report is to be submitted to the Surveyor and attached to the testing documentation.

1.8.4 Welding procedure

In the welding procedure the following features are to be taken into account:

- a) important castings and alloy steel castings are to be given a suitable preliminary heat treatment prior to carrying out weld repairs. A similar heat treatment may also be required for other types of castings where the repair of a major defect is proposed
- b) the excavations are to be suitably shaped to allow good access for welding and, after final preparation for welding, they are to be re-examined by suitable non-destructive

tive testing methods to ensure that all defective material has been eliminated

- c) all castings in alloy steels, other than austenitic and austenitic-ferritic stainless steels and all crankshaft castings, are to be suitably preheated prior to welding. Castings in carbon or carbon-manganese steel may also be required to be pre-heated depending on their chemical composition and the dimensions and position of the weld repairs
- d) welding is to be done under cover in positions free from draughts and adverse weather conditions by qualified welders with adequate supervision. As far as possible, all the weldings are to be carried out in the down-hand (flat) position
- e) the welding consumables used are to be of an appropriate composition giving a weld deposit with mechanical properties similar and in no way inferior to those of the parent castings. The use of low hydrogen type welding consumables is preferred and may be required. Consideration is to be given to the effect of post-weld heat treatment on the mechanical properties of the weld metal.
Welding procedure tests are to be carried out by the Manufacturer to demonstrate that satisfactory mechanical properties can be obtained after heat treatment as detailed in [2.3.1] and [3.3.1]
- f) after welding has been completed, the castings are to be given either a suitable heat treatment in accordance with the requirements in [1.9], or a stress relieving heat treatment at a temperature not lower than 550°C. The type of heat treatment employed will be dependent on the chemical composition of the casting and the dimensions, position and nature of the repairs
- g) special consideration may be given to the omission of post-weld heat treatment or to the acceptance of a local stress relieving heat treatment where the repaired area is small and machining of the casting has reached an advanced stage
- h) on completion of heat treatment, the weld repairs and adjacent material are to be ground smooth and examined by magnetic particle or liquid penetrant testing. Supplementary ultrasonic or radiographic examination may also be required depending on the dimensions and nature of the original defect. Satisfactory results are to be obtained from all forms of non-destructive testing used.

For the rectification of defects on castings for crankshafts, see also [4.7.2].

1.8.5 The Manufacturer is to maintain full records detailing the extent and location of repairs made to each casting and details of weld procedures and heat treatments applied for repairs. These records are to be available to the Surveyor and copies provided on request.

1.9 Condition of supply - heat treatment

1.9.1 Castings are to be suitably heat treated to refine the grain structure and obtain the required mechanical properties.

Heat treatment is to be carried out in suitable furnaces. See Ch 1, Sec 1, [2.3.1].

If a casting is locally reheated or any straightening operation is performed after the final heat treatment, a subsequent stress relieving heat treatment may be required in order to avoid the possibility of harmful residual stresses.

1.9.2 The heat treatment conditions foreseen are indicated in the Articles relevant to the various castings.

When more than one heat treatment condition is specified, the choice of the supply condition, unless otherwise required, is left to the Manufacturer; the condition of supply is always to be mentioned in the testing documentation.

1.10 Pressure test

1.10.1 Castings subject to internal pressure are to be subjected to a hydraulic pressure test in compliance with the conditions laid down in the applicable parts of the Rules.

The test pressure is to be measured by means of a suitable calibrated pressure gauge.

The test is to be performed on the casting in the finished condition and before the application of any coating which may conceal the effect of the test.

Unless otherwise agreed, the test of class 1 castings is to be carried out in the presence of the Surveyor.

A report confirming the satisfactory results of the pressure tests and indicating the relevant testing conditions is to be issued by the Manufacturer.

1.11 Sampling and testing

1.11.1 General

The requirements relevant to the type and number of tests to be carried out are indicated in the Articles relevant to the various applications.

The test samples are to be sufficient for the required tests and for possible re-test purposes, and are to be taken from castings in the supply condition.

The samples are to have a thickness of not less than 30mm.

1.11.2 Individual testing

In the case of individual testing, the sample is to be integral with each casting [1.11.5].

1.11.3 Batch testing

A batch testing procedure may be adopted in the following cases:

- a) small class 1 castings (generally having mass not exceeding 200 kg) of about the same size, made from one cast and heat treated in the same furnace charge; the total mass of the batch is not to exceed 2,5 t
- b) class 2 castings of the same type of steel, of approximately the same size, having mass not exceeding 1000 kg and subjected to the same heat treatment; the total mass of the batch is not to exceed 4 t.

The test samples may be cut from one or more castings [1.11.5] of the batch or, alternatively, separately cast samples may be used. When cast samples are used, they are to

be properly identified and heat treated together with the castings of the batch.

1.11.4 Homogeneity of the batch

Where a batch testing procedure is used, hardness tests may be required, at the discretion of the Surveyor, to check the homogeneity of the batch.

1.11.5 Sampling

In the case of individual testing [1.11.2], each casting is to be provided with at least the following test samples:

- a) 1 test sample for castings of plain design, provided the finished mass does not exceed 10 t
- b) 2 test samples for castings of complex design or where the finished mass exceeds 10 t
- c) 2 or more test samples corresponding to the number of casts involved, in the case of large castings made from two or more casts which are not mixed in a ladle prior to pouring.

When more than one test sample is provided for the same casting, the test samples are to be integrally cast at locations as widely separated as possible.

For castings where the method of manufacture has been specially approved by ^{Tasneef} in accordance with [1.4.1], the number and position of test samples are to be agreed with the Classification Society having regard to the method of manufacture employed.

In the case of batch testing [1.11.3], when the castings in the batch are 20 or less one sample is required to be taken from the casting representative of the batch; where the number of pieces in the batch exceeds 20, two samples are required per batch.

The test samples are not to be detached from the casting until the specified heat treatment has been completed and they have been properly identified.

A set of specimens is to be cut from each sample for the execution of one tensile test.

1.11.6 Preparation of test specimens

For the preparation of test specimens and relevant testing procedure, reference is to be made to the applicable requirements of Ch 1, Sec 2.

1.11.7 Tensile and hardness tests

The results of the tensile test at ambient temperature are to comply with the requirements of the appropriate Tables, or of the relevant approved specification when steels other than those specified in these Rules are accepted.

The Tables give the minimum requirements corresponding to different strength levels but it is not intended that these values should necessarily be regarded as specific rule grades.

The strength levels are given in multiples of 40 N/mm²; where intermediate levels are accepted, the properties may be obtained by interpolation.

For the properties at elevated temperatures and their verification, when required, see [5.5.1].

Hardness tests of Brinell type may be required for specific applications or, in general, as verification of the homogeneity, at the discretion of the Surveyors. See [1.11.4].

The results of hardness tests are to be in agreement with the appropriate values of the steel tested.

1.11.8 Re-test procedures

Samples for possible re-tests are to be taken as near as practicable to the specimens used for the original tests; however, at the discretion of the Surveyors, they may also be taken from other positions or pieces deemed representative of the casting or batch.

Where the result of a tensile test does not comply with the requirements, two additional tests may be taken. If satisfactory results are obtained from both of these additional tests the casting or batch of castings is acceptable. If one or both retests fail the castings or batch of castings is to be rejected.

The additional tests are to be taken, preferably from the same, but alternatively from another test sample representative of the casting or batch of castings.

Re-test procedures are specified in Ch 1, Sec 1, [3.5].

At the discretion of the Manufacturer, when a casting or batch of castings has failed to meet the test requirements, it may be reheat treated and re-submitted for acceptance tests.

1.12 Identification and marking

1.12.1 The Manufacturer is to adopt a system of identification which will enable all finished castings to be traced to the original cast and their manufacturing.

All castings which have been tested and inspected with satisfactory results are to be marked with the following details:

- a) Manufacturer's name or trade mark
- b) Society's brand
- c) identification mark for the grade of steel
- d) cast number or other marking which will enable the history of the fabrication of the casting to be traced
- e) additional, optional marks such as file number and code of the local inspection office, Surveyor's personal brand
- f) test pressure, where applicable.

Modified arrangements for identification and marking may be agreed in the case of small castings manufactured in large numbers.

1.13 Documentation and certification

1.13.1 The testing documentation indicated in Ch 1, Sec 1, [4.2.1] is to be issued and is to include all the information, as appropriate.

The ladle analysis is to include the content of refining and alloying elements as applicable.

Where applicable, details of heat treatment including temperatures and holding times as well as the reports relevant to the non-destructive examination [1.7.1], weld repair [1.8.3] and pressure test [1.10.1] are to be enclosed with the testing documentation.

2 Casting for hull and other welded structures in general

2.1 Application

2.1.1 The requirements of this Article apply to carbon and carbon-manganese steel castings intended for hull and other welded structures in general, where design and acceptance tests are related to mechanical properties at ambient temperature.

2.1.2 Castings intended for use in the construction of stems, sternframes, rudder and propeller shaft supports belong to class1; unless otherwise specified, on a case-by-case basis, other castings belong to class2.

2.2 Steel grades

2.2.1

The steel grades are identified by the letter G, followed by a number indicating the minimum specified tensile strength R_m (in N/mm²).

2.2.2 Limits on the specified minimum tensile strength and grades to be used for hull structures are given in Part B and/or in the relevant approved plans.

In particular, the use of the grades G480 to G600 may be restricted to specific conditions.

2.3 Condition of supply

2.3.1 Castings are to be supplied in one of the following conditions, as required by the steel specification (see [1.9.2]):

- fully annealed
- normalised
- normalised and tempered
- quenched and tempered.

The tempering temperature is to be not less than 550°C.

2.4 Chemical composition

2.4.1 All castings are to be made from killed steel.

Suitable grain refining elements, such as Al, Nb, V, may be used and the content of such elements is to be reported.

The chemical composition is to be appropriate for the type of steel, dimensions and required mechanical properties of the casting.

The chemical composition on ladle analysis is to comply with the limits given in Tab 1.

When alloy steels are proposed, details of chemical composition, heat treatment, mechanical properties, testing inspections and rectification methods are to be submitted for consideration and approval.

2.5 Mechanical properties

2.5.1 The requirements for yield stress, elongation and reduction of area are to comply with the requirements of Tab 2 appropriate to the specified minimum tensile strength or, where applicable, the requirements of the approved specification.

Castings may be supplied at any specified minimum tensile strength selected within the limits detailed in Tab 2 but subject to any additional requirements of the construction Rules relevant to the specific application.

Where it is proposed to use a steel with a specified minimum tensile strength intermediate to those given, corresponding minimum values for the other properties may be obtained by interpolation.

2.6 Mechanical tests

2.6.1 The number of test samples required in the case of individual [1.11.2] or batch [1.11.3] testing is indicated in [1.11.5].

The test specimens for the tensile test are to be taken from each test sample.

2.7 Non-destructive examination

2.7.1 Castings intended for the construction of sternframes, poop structure, rudders and propeller shaft supports are to be non-destructively tested by ultrasonic and magnetic methods.

Other castings are to be examined by non-destructive test methods as required by the approved plans, by the purchase order or, in specific cases, by the Surveyor.

Table 1 : Chemical composition

Steel type	Applications	C (max.)	Si (max.)	Mn	S (max.)	P (max.)	Residual elements (max.)				Total residuals (max.)
							Cu	Cr	Ni	Mo	
C,C-Mn	Castings for non-welded construction	0,40	0,60	0,50 - 1,60	0,040	0,040	0,30	0,30	0,40	0,15	0,80
	Castings for welded construction	0,23	0,60	1,60 max	0,040	0,040	0,30	0,30	0,40	0,15	0,80

Table 2 : Mechanical properties

Specified minimum tensile strength (1) (N/mm ²) min.	Yield stress (N/mm ²) min.	Elongation on 5,65 S ₀ ^{0.5} (%) min.	Reduction of area (%) min.
400	200	25	40
440	220	22	30
480	240	20	27
520	260	18	25
560	300	15	20
600	320	13	20

(1) A tensile strength range of 150 N/mm² may additionally be specified.

3 Castings for machinery and equipment

3.1 Application

3.1.1 The requirements of this Article apply to carbon and carbon-manganese steel castings, intended for use in the construction of machinery, equipment and components not specifically dealt with in the other Articles of this Section.

Provisions for castings for copper alloy and steel propellers and for anchors are given in Ch 4, Sec 2, [1] Ch 4, Sec 2, [1] and Ch 4, Sec 1, [1], respectively.

3.1.2 Castings intended for parts of engine bedplates, cylinder and piston heads, turbine casings, components in general of important machinery, rudders and anchors belong to class 1; unless otherwise specified on a case-by-case basis, other castings belong to class 2.

3.2 Steel grades

3.2.1 Grades are identified by the letter G, followed by a number indicating the minimum specified tensile strength R_m (N/mm²).

When alloy steels are proposed, details of chemical composition, heat treatment, mechanical properties, testing inspections and rectification method are to be submitted for consideration and approval.

3.3 Condition of supply

3.3.1 Castings are to be supplied in one of the following conditions, as required by the steel specification (see [1.9.2]):

- fully annealed
- normalised, or
- normalised and tempered at a temperature not lower than 550°C
- quenched and tempered.

The tempering temperature is to be not less than 550°C.

Castings for components such as engine bedplates, turbines and other castings in general, where dimensional stability and freedom from internal stresses are important, are to be subjected to an additional stress relief heat treatment at a

temperature not lower than 550°C and then cooled in the furnace to 300°C or lower. When the full annealing or the tempering of the normalised and tempered steels is followed by furnace cooling to 300°C or lower, the stress relief treatment is not required.

3.4 Chemical composition

3.4.1 All castings are to be made from killed steel.

Suitable grain refining elements, such as Al, Nb, V, may be used and the content of such elements is to be reported in the ladle analysis.

The chemical composition is to be appropriate for the type of steel, dimensions and required mechanical properties of the castings.

The chemical composition on ladle analysis is to comply with the limits given in Tab 1.

For castings in alloy steel and in other steels accepted on the basis of their approved specification, the full chemical composition (ladle analysis) is to comply with the applicable specification; the ladle analysis is to include all the alloy elements.

3.5 Mechanical properties

3.5.1 The requirements for yield stress, elongation and reduction of area are to comply with the requirements of Tab 2 appropriate to the specified minimum tensile strength or, where applicable, the requirements of the approved specification.

Castings may be supplied at any specified minimum tensile strength selected within the limits detailed in Tab 2 but subject to any additional requirements of the construction Rules relevant to the specific application.

Where it is proposed to use a steel with a specified minimum tensile strength intermediate to those given, corresponding minimum values for the other properties may be obtained by interpolation.

3.6 Mechanical tests

3.6.1 The number of test samples required in the case of individual [1.11.2] or batch [1.11.3] testing is indicated in [1.11.5].

The test specimens for the tensile test is to be taken from each test sample.

3.7 Non-destructive examination

3.7.1 Ultrasonic examination is to be carried out on the following items:

- a) piston crowns and cylinder covers
- b) parts of engine bedplates
- c) turbine casings
- d) rudder components.

3.7.2 A magnetic particle examination is to be carried out for the following items:

- a) piston crowns and cylinder covers for engines having a bore size greater than 400 mm
- b) parts of engine bedplates
- c) turbine casings
- d) rudder components.

The parts to be examined and the test procedures are to be agreed with the Surveyor.

Other castings are to be examined by non-destructive test methods as required by the approved plans, by the purchase order or, in specific cases, by the Surveyor.

4 Castings for crankshafts

4.1 Application

4.1.1 The requirements of this Article apply to carbon and carbon-manganese steel castings intended for the construction of semi-built and fully built crankshafts.

Alloy steel castings are subject to approval; the detailed specification is to be preliminarily submitted.

The general requirements, specified in Article [1], are also to be complied with, as appropriate.

4.1.2 Castings intended for crankshafts belong to class 1.

4.2 Steel grades

4.2.1 As for the chemical composition and mechanical properties, the requirements of [3.2] apply; in the case of particular steels the relevant specification is to be preliminarily submitted for approval.

In connection with the requirements of Pt C, Ch 1, Sec 2, [2.1], the specified minimum tensile strength R_m :

- for non-alloyed steels is not to be higher than 560 N/mm²
- for alloyed steels is not to be higher than 700 N/mm².

4.3 Manufacture

4.3.1 The method of manufacturing is to be approved and approval tests are required to verify the soundness and the properties at significant locations of the castings.

4.4 Condition of supply

4.4.1 Castings are to be supplied in one of the following conditions, as required by the steel specification (see [1.9.2]):

- fully annealed and cooled in the furnace to 300°C or less
- normalised and tempered to a temperature not lower than 550°C, then cooled in the furnace to 300°C or less.

4.5 Chemical and mechanical properties

4.5.1 For carbon and carbon-manganese steel the chemical composition is to comply with the requirements of Tab 1 or the approved specification, as appropriate.

4.5.2 As regards the mechanical properties, the minimum requirements for carbon and carbon-manganese steels are indicated in Tab 2, For steels complying with an approved specification, in particular for alloyed steels, the relevant requirements of such specification apply.

4.6 Mechanical tests

4.6.1 The number and position of the specimens for mechanical tests are specified at the time of approval of the method of manufacture.

4.7 Non-destructive examinations and rectification of defects

4.7.1 Non-destructive examination

Magnetic particle testing is required on all surfaces of the castings in the finished condition.

Where applicable, this test is also to be performed on all flame-cut surfaces not subsequently machined.

Ultrasonic testing is required for all castings.

The directions and procedures for such examinations as well as the evaluation of the relevant indications, complying with the requirements of the engine Manufacturer, are to be previously approved by ^{Tasneef}

4.7.2 Rectification of defects

Surface defects are to be removed by grinding or machining.

Proposals to repair by welding accidental defects which cannot be dealt with as above and which have moderate extension and are not situated in critical locations for the service behaviour, are to be submitted for approval to ^{Tasneef} with any necessary detail. In any case, the conditions provided for in [1.8.3] are to be complied with.

5 Castings for boilers, pressure vessels and systems

5.1 Application

5.1.1 The requirements of this Article apply to steel castings which may be subjected to welding, intended for the construction of boilers, pressure vessels, plants and piping systems in general, operating at temperatures not lower than 0°C.

5.1.2 Castings intended for use in the construction of pressure vessels and piping systems of class 1 as defined in Part C belong to class 1.

5.1.3 Castings intended for vessels and systems operating at temperatures lower than 0°C are to comply with the applicable requirements of Article [6] in the case of applications involving the storage and transport of liquefied gases, also with those specified in Pt E, Ch 1, Sec 14 of the Rules.

5.2 Steel grades

5.2.1 The requirements apply to carbon and carbon-manganese steels and low alloy steels (Mo and Cr-Mo steels).

The C and C-Mn steels are classed into three groups and are identified by the minimum ultimate tensile strength R_m (in N/mm²) 400, 440, 480, followed by the letter P.

Carbon and carbon-manganese steels having a minimum specified tensile strength R_m greater than the above but not exceeding 520 N/mm² may be accepted, at the discretion of T_{asneef} on the basis of their detailed specification.

5.2.2 Low alloy steels are designated according to the chemical composition into the grades 0,3Mo - 1Cr0,5Mo - 2,25Cr1Mo - 0,5Cr0,5Mo0,25V.

The figures mean the nominal percentage content of the main alloying elements.

5.3 Condition of supply

5.3.1 Castings are to be supplied in one of the following conditions, as required by the steel specification (see [1.9.2]):

- fully annealed
- normalised
- normalised and tempered
- quenched and tempered.

The tempering temperature is to be not lower than 550°C.

5.4 Chemical composition and mechanical properties

5.4.1 Chemical composition

For steels in accordance with these Rules, the chemical composition on ladle analysis is to comply with the requirements specified in Tab 3.

In the case of steels accepted as an alternative to the above, the approved specification is applicable.

5.4.2 Mechanical properties

For steels in accordance with these Rules, the mechanical properties are indicated in Tab 4.

In the case of steels accepted as an alternative to the above, the approved specification is applicable.

5.5 Mechanical properties at elevated temperature

5.5.1 The values for the 0,2% proof stress ($R_{p0,2}$), at temperatures of 150°C and higher, are given in Tab 5.

The above values are for design purposes only. Their verification is generally not required at the individual inspection of material.

5.5.2 Where, however, a verification of the properties at elevated temperature (above 200°C) is required, the following procedure applies, unless otherwise agreed:

- a tensile test to verify the yield stress is to be performed at an agreed temperature (in relation to the design temperature) rounded to the nearest multiple of 50°C
- the test is to be carried out on samples properly taken from the castings selected
- the test samples are to be heat treated, as required, together with the casting they represent
- the test procedure is to be in compliance with the relevant requirements of Ch 1, Sec 2, [2.1] and Ch 1, Sec 2, [2.2.5]
- the result of the test is to comply with the $R_{p0,2}$ yield stress value specified at the test temperature concerned.

5.5.3 Where figures higher than those shown in Tab 5 and in accordance with recognised standards are proposed by the steel Manufacturer, their verification is required and procedures similar to those detailed in Sec 1, [4.7.2] are to be followed in agreement with T_{asneef}

5.5.4 The values of the estimated average stress to rupture in 100.000 hours, for design purposes only, are given in Sec 1, Tab 19.

Table 3 : Chemical composition

Steel grade	Chemical composition (%) (1)								
	C	Mn	Si	P max	S max	Cr	Mo	V	Ni max
400 P	≤ 0,23	0,50-1,20	≤ 0,60	0,035	0,035	≤ 0,30	≤ 0,15	-	-
440 P	≤ 0,23	0,50-1,20	≤ 0,60	0,035	0,035	≤ 0,30	≤ 0,15	-	0,40 (1)
480 P	≤ 0,25	0,60-1,60	≤ 0,60	0,035	0,035	≤ 0,30	≤ 0,15	-	0,40 (1)
0,5Mo	0,15-0,23	0,50-1,00	0,30-0,60	0,035	0,035	≤ 0,30	0,40-0,60	-	0,40
1Cr0,5Mo	0,10-0,20	0,50-1,00	0,30-0,60	0,035	0,035	1,00-1,50	0,45-0,65	-	0,40
2,25Cr1Mo	0,13-0,20	0,50-1,00	0,30-0,60	0,035	0,035	2,00-2,50	0,90-1,20	-	0,40
0,5Cr0,5Mo0,25V	0,10-0,18	0,40-0,80	0,30-0,60	0,035	0,035	0,70-1,10	0,40-0,60	0,22-0,30	0,40

(1) With the exception of refining elements, additional alloying elements are to be submitted for consideration and approval. Residual elements are not to exceed the following limits (%):
for C and C-Mn steels: Cu ≤ 0,30 ; total : Ni+Cu+Cr+Mo ≤ 0,80
for alloy steels : Cu ≤ 0,30

Table 4 : Mechanical properties

Steel grade	Yield stress R_{eH} (N/mm ²) min.	Tensile strength (N/mm ²)	Elongation A_5 (%) min.	Reduction of area Z (%) min.	Average impact energy (J) at +20°C
					V- or U-notch
400 P	200	400 - 550	25	40	27
440 P	230	440 - 590	22	38	27
480 P	250	480 - 630	20	30	27
0,5Mo	245	450 - 600	21	35	25
1Cr 0,5Mo	290	480 - 630	18	35	25
2,25Cr 1Mo	280	500 - 650	18	35	25
0,5Cr 0,5Mo 0,25V	310	500 - 650	17	35	16

Table 5 : Minimum proof stress ($R_{p0,2}$) values at elevated temperatures

Steel grade	$R_{p0,2}$ (N/mm ²) at a temperature (°C) of									
	150	200	250	300	350	400	450	500	550	600
400 P 440 P 480 P	210	200	185	160	155	150	135			
0,5Mo	235	225	205	185	175	170	155	145	135	125
1Cr 0,5Mo		200		195		185		160		115
2,25Cr 1Mo	310	305	295	290	280	270	255	240	210	180
0,5Cr 0,5Mo 0,25V		245		300		215		195		145

Note 1: The values at $R_{p0,2}$ for temperatures $\leq 200^\circ\text{C}$ are for guidance only.

5.6 Mechanical tests

5.6.1 The number of test samples required in the case of individual [1.11.2] or batch [1.11.3] testing is indicated in [1.11.5].

The test specimens for 1 tensile and 3 Charpy V- or U-notch impact tests are to be taken from each test sample. Impact tests may be omitted for class 2 castings.

5.7 Non-destructive examination

5.7.1 The castings are to be examined by means of the non-destructive tests required by the applicable Rules or specified in the approved plans or in the purchase order; checks of soundness may also be required in individual cases at the discretion of the Surveyor.

6 Ferritic steel castings for low temperature service

6.1 Application

6.1.1 The requirements of this Article apply to ferritic steel castings intended for welded structural use as in the construction of structures, vessels, plants and piping systems for low temperature service or when, irrespective of the service

conditions, they are required to satisfy specified impact properties at temperatures lower than 0°C.

6.1.2 Unless otherwise agreed, castings covered by this Article belong to class 1.

6.1.3 In the case of applications involving the storage and transport of liquefied gases or fluids at low temperature in general, the appropriate requirements of Pt E, Ch 1, Sec 14 of the Rules also apply.

6.2 Steel grades

6.2.1 The requirements apply to carbon-manganese and nickel alloy steels specified in [6.2.2] [6.2.3].

Steels different from the above may be considered on the basis of the respective specifications relevant to chemical composition, mechanical properties and heat treatment to be submitted individually for approval.

6.2.2 Carbon-manganese steels are classed into three groups indicated by the minimum ultimate tensile strength R_m : 400, 440 or 480 N/mm².

Each group is further subdivided into three grades: LD, LE and LF, based on the impact test temperature specified at -20°C, -40°C and -60°C, respectively.

6.2.3 Ni alloy steels are designated according to the chemical composition into the grades 2,5Ni and 3,5Ni. The figures mean the Ni nominal percentage content.

6.3 Condition of supply

6.3.1 Castings are to be normalised, normalised and tempered or quenched and tempered; see also [1.9.2].

The tempering temperature is to be not lower than 550°C.

6.4 Chemical composition and mechanical properties

6.4.1 Chemical composition

All castings are to be made from killed and fine grained steel.

The chemical composition on ladle analysis is to comply with the limits indicated in Tab 6.

6.4.2 Mechanical properties

The mechanical properties are specified in Tab 7.

6.5 Mechanical tests

6.5.1 The number of tests samples required in the case of individual [1.11.2] or batch [1.11.3] testing is indicated in [1.11.5].

The test specimens for 1 tensile and 3 Charpy V-notch impact tests are to be taken from each test sample.

The impact tests are generally to be carried out at the temperature stated for the type of steel; a higher test temperature may be agreed with *Tasneef* however, depending on the design service temperature of the individual applications.

6.6 Non-destructive examination

6.6.1 The castings are to be examined by means of the non-destructive tests required by the applicable Rules or specified in the approved plans or in the purchase order; checks of soundness may also be required in individual cases at the discretion of the Surveyor.

7 Stainless steel castings

7.1 Application

7.1.1 The requirements of this Article apply to stainless steel castings intended for construction of cargo tanks, pressure vessels and piping fittings for chemicals and/or low temperature applications.

7.1.2 Unless otherwise agreed, the castings covered by this Article belong to class 1.

Table 6 : Chemical composition

Steel grade	Chemical composition (%) (1)							
	C max	Mn	Si	P max	S max	Ni	Al tot	Others
400 LD-LE-LF	0,23	0,50 - 1,20	0,30 - 0,60	0,035	0,035	≤ 0,80	≥ 0,020	Cr ≤ 0,25 Cu ≤ 0,30 Mo ≤ 0,15
440 LD-LE-LF	0,23	0,60 - 1,30	0,30 - 0,60	0,035	0,035	≤ 0,80	≥ 0,020	
480 LD-LE-LF	0,25	0,60 - 1,30	0,30 - 0,60	0,035	0,035	≤ 0,80	≥ 0,020	
2,5Ni	0,16	0,50 - 0,80	0,30 - 0,60	0,035	0,035	2,00 - 3,00	-	
3,5Ni	0,14	0,50 - 0,80	0,30 - 0,60	0,035	0,035	3,00 - 4,00	-	

(1) With the exception of refining elements, additional alloying elements are to be submitted for consideration and approval.

Table 7 : Mechanical properties

Steel grade	Yield stress R_{eH} (N/mm ²) min.	Tensile strength R_m (N/mm ²)	Elongation A_5 (%) min.	Reduction of area Z (%) min.	Average impact energy (J) min.	
					Test temp (°C)	KV
400 LD	200	400 - 550	25	40	- 20	27
400 LE					- 40	
400 LF					- 60	
440 LD	230	440 - 590	22	35	- 20	27
440 LE					- 40	
440 LF					- 60	
480 LD	250	480 - 630	20	30	- 20	27
480 LE					- 40	
480 LF					- 60	
2,5Ni	275	490 - 640	20	35	- 60	35
3,5 Ni	275	490 - 640	20	35	- 80	35

7.1.3 The service conditions of austenitic stainless steel castings may be at both elevated temperatures and low temperatures.

When the castings are for use at elevated temperatures, the specification of the proposed steel relative to chemical composition, heat treatment and mechanical properties is to be submitted for consideration and approval.

7.1.4 In the case of applications involving the storage and transport of liquefied gases or fluids at low temperature in general, the requirements of Pt E, Ch 1, Sec 14 of the Rules also apply as appropriate.

7.2 Steel grades and relevant properties

7.2.1 General

The requirements apply to austenitic Cr-Ni steels.

Note 1: The steels are designated according to the corresponding AISI type.

Austenitic Cr-Ni steels are required to comply with the chemical composition and mechanical properties indicated in Tab 8 and Tab 9, or with recognised standards or specifications submitted for acceptance.

Other types of stainless steels (ferritic-austenitic), complying with international or national specifications, may be considered for particular applications; the relevant specification of the proposed steel is to be submitted for acceptance.

7.2.2 Condition of supply

The castings are to be solution heat treated in accordance with recognised standards or approved specifications.

7.2.3 Chemical composition

Refer to Tab 8.

7.2.4 Mechanical properties

Refer to Tab 9.

7.3 Mechanical tests

7.3.1 The number of test samples required in the case of individual [1.11.2] or batch [1.11.3] testing is indicated in [1.11.5].

A specimen for 1 tensile test is to be taken from each test sample; in cases when the following sentence applies, three specimens for CV notch impact testing are also to be taken.

Unless otherwise required, impact tests on the austenitic grades are to be performed for service temperature below -105°C and are to be carried out at -196°C.

7.4 Non-destructive examination

7.4.1 Unless otherwise agreed, class 1 castings are to be examined by the liquid penetrant and/or ultrasonic methods, as required, depending on the application.

7.5 Corrosion tests

7.5.1 For castings intended for chemicals, the corrosion tests, ASTM A262 Practice E (Copper-copper sulphate sulphuric) or ASTM A262 Practice C (Nitric acid test) as appropriate, may be required to be carried out on one piece per batch.

Tests in accordance with other recognised standards are accepted subject to the agreement of Tasneef

Table 8 : Chemical composition

AISI grade designation	Chemical composition (%)								
	C max	Mn max	Si max	P max	S max	Cr	Ni	Mo	Others
304L	0,030	2,0	1,5	0,040	0,030	17,0-21,0	8,0 - 12,0	-	
304	0,080	2,0	1,5	0,040	0,030	17,0-21,0	8,0 - 12,0	-	
316L	0,030	2,0	1,5	0,040	0,030	17,0-21,0	9,0 - 13,0	2,0 - 3,0	
316	0,080	2,0	1,5	0,040	0,030	17,0-21,0	9,0 - 13,0	2,0 - 3,0	
347	0,080	2,0	1,5	0,040	0,030	17,0-21,0	9,0 - 13,0	-	10xC ≤ Nb ≤ 0,80

Table 9 : Mechanical properties

AISI grade designation	Yield strength R _{p1.0} (N/mm ²) min.	Tensile strength R _m (N/mm ²) min.	Elong. A ₅ (%) min.	Reduction of area Z (%) min.	Average impact energy min. KV at -196°C
304 L	215	430	26	40	41
304	220	480	26	40	41
316L	215	430	26	40	41
316	240	480	26	40	41
347	215	480	22	35	41

SECTION 5

IRON CASTINGS

1 General

1.1 Application

1.1.1 General

The requirements of this Section apply to grey lamellar graphite (GG) and spheroidal graphite (SG) iron castings, to be used for the construction of ship structures, machinery, boilers, pressure vessels and piping systems.

The use of cast iron components and the types of cast iron permitted are either regulated by the Sections of the Rules relevant to the construction of the above-mentioned components, or stipulated in each case.

This Article specifies the requirements common to all the above cast iron products, while the appropriate specific requirements are indicated in Articles [2] and [3].

1.1.2 Mass production

For mass produced small castings, the Manufacturer may adopt modified procedures for testing and inspection subject to the approval of ^{Tasneef}

1.2 Casting designation

1.2.1 The abbreviated designations identifying the cast iron types for the purpose of ^{Tasneef} requirements are constituted as follows:

- a) a first symbol depending on the category:
 - “GG” for grey lamellar graphite
 - “SG” for spheroidal or nodular graphite
- b) a second symbol representing the value of the minimum tensile strength R_m , in N/mm².

1.3 Manufacture

1.3.1 All castings are to be made at foundries where the Manufacturer has demonstrated, to the satisfaction of ^{Tasneef} that the necessary manufacturing and testing facilities are available and are supervised by qualified personnel. In some cases, ^{Tasneef} may request the Surveyor to proceed with a preliminary visit of the manufacturer's works and to ask for preliminary tests of approval.

1.3.2 Suitable mechanical methods are to be employed for the removal of surplus material from castings. Thermal cutting processes (flame cutting, arc-air cutting) are not acceptable, except as a preliminary operation prior to mechanical methods.

1.3.3 In connection with [1.1.2] to have an inspection procedure adapted to this kind of manufacture, the Manufacturer is to carry out any tests necessary to prove the quality of the prototype castings, as well as periodical examinations

to verify the continued efficiency of the manufacturing technique. The Surveyor is to be given the opportunity to witness these tests.

1.4 Quality of castings

1.4.1 Castings are to be free from surface or internal defects which would be prejudicial to their proper application in service.

The surface finish is to be in accordance with good practice and any specific requirements of the approved plans or purchase order.

1.5 Visual, dimensional and non-destructive examination

1.5.1 All castings are to be cleaned and adequately prepared for examination. The surfaces are not to be hammered, peened or treated in any way which may obscure defects.

1.5.2 Before acceptance, all castings are to be visually examined including, where applicable, the examination of internal surfaces.

1.5.3 Dimensions, tolerances and their verification are the responsibility of the Manufacturer.

1.5.4 The non-destructive examination of castings is not required, unless otherwise specified for particular applications or on the approved drawings or when there are grounds for suspecting the soundness of the casting.

Where the above-mentioned check is required, operators are to be qualified according to the requirements of Ch 1, Sec 1, [3.6.4], equipment are to be reliable and the examination procedures are to be approved by the Surveyor.

1.5.5 When requested in the relevant parts of the Rules, castings are to be pressure tested.

These tests are to be carried out in the presence of the Surveyor.

1.6 Repair of defects

1.6.1 At the discretion of the Surveyor, small surface blemishes may be removed by grinding.

1.6.2 Subject to the prior approval of the Surveyor, local porosity may be rectified by impregnation with a suitable plastic filler, provided that the extent of the porosity is such that it does not adversely affect the strength of the casting.

1.6.3 Repairs by welding are generally not permitted. However, in certain circumstances and in particular when

the mechanical strength of the casting is not involved, a repair by welding may be considered.

In such case, all details of the proposed repair together with the welding procedure foreseen are to be submitted to Tasneef for examination and approval before the repair work commences.

1.7 Chemical composition

1.7.1 The chemical composition of the iron used is left to the discretion of the Manufacturer, who is to ensure that it is suitable to obtain the mechanical properties specified for the castings.

1.7.2 When required, the chemical composition of ladle samples is to be reported.

1.8 Condition of supply

1.8.1 Except as required in [1.8.2], castings may be supplied in either the as cast or the heat treated condition.

1.8.2 For certain applications such as elevated temperature service, or where dimensional stability is important, castings may be required to be given a suitable tempering or stress relieving heat treatment. This is to be carried out after any refining heat treatment and before machining.

1.9 Sampling and testing

1.9.1 Test material sufficient for the required tests and possible re-tests is to be provided for each casting or batch of castings.

1.9.2 Where separately cast test samples are used, they are to be cast in moulds made from the same type of material as that used for the castings and are to be taken towards the end of pouring of the castings. The samples are not to be stripped from the moulds until the metal temperature is below 500°C.

1.9.3 Where castings are supplied in the heat treated condition, the test samples are to be heat treated together with the castings which they represent. For cast-on samples, the sample is not to be cut off from the casting until the heat treatment is complete.

1.9.4 All test samples are to be suitably marked to identify them with the castings which they represent.

1.9.5 A batch testing procedure may be adopted for castings with a fettled mass of 1 ton or less. All castings in a batch are to be of similar type and dimensions, and cast from the same ladle of treated metal. One test sample is to be provided for each multiple of 2 tons of fettled castings in each batch.

1.9.6 One test sample is to be provided for each casting or batch of castings.

For large castings where more than one ladle of treated metal is used, additional test samples are to be provided so as to be representative of each ladle used.

1.9.7 Where the results of a tensile or impact test do not comply with the requirements, the re-test procedure indicated in Ch 1, Sec 1, [3.5] may be applied.

1.10 Identification and marking

1.10.1 All castings which have been tested and inspected with satisfactory results are to be marked with the following details:

- a) Manufacturer's name or trade mark
- b) Society's brand
- c) identification mark for material designation, as indicated in [1.2]
- d) cast number or other marking which will enable the history of the fabrication of the casting to be traced
- e) test pressure, where applicable
- f) additional optional marks such as file number and code of the local inspection office, Surveyor's personal brand.

Modified arrangements for identification and marking of small castings manufactured in large numbers may be agreed.

1.11 Documentation and certification

1.11.1 The testing documentation indicated in Ch 1, Sec 1, [4.2.1] is to be issued and is to include all the information, as appropriate.

When required, the chemical analysis of ladle samples is to be reported.

Where applicable, the reports relevant to the non-destructive examination and pressure test are to be enclosed with the testing documentation.

2 Grey iron castings

2.1 Application

2.1.1 The requirements of this Article apply to grey iron castings (GG iron castings).

The general requirements specified in Article [1] are also to be complied with, as appropriate.

2.2 Test material

2.2.1 One test sample is to be provided for each casting or batch of castings and, unless otherwise required, may be either gated to the casting or separately cast.

2.2.2 Separately cast test samples are to be used unless otherwise agreed between the Manufacturer and purchaser and generally are to be in the form of bars 30 mm in diameter and of a suitable length.

They are to be cast from the same ladle as the castings in moulds of the same type of material as the moulds for the castings and are not to be stripped from the moulds until the metal temperature is below 500°C. When two or more test samples are cast simultaneously in a single mould, the bars are to be at least 50 mm apart as shown in Fig 1.

In the case of specific components, test samples of other dimensions may be specially required or agreed.

Figure 1 : Test Sample for grey cast iron

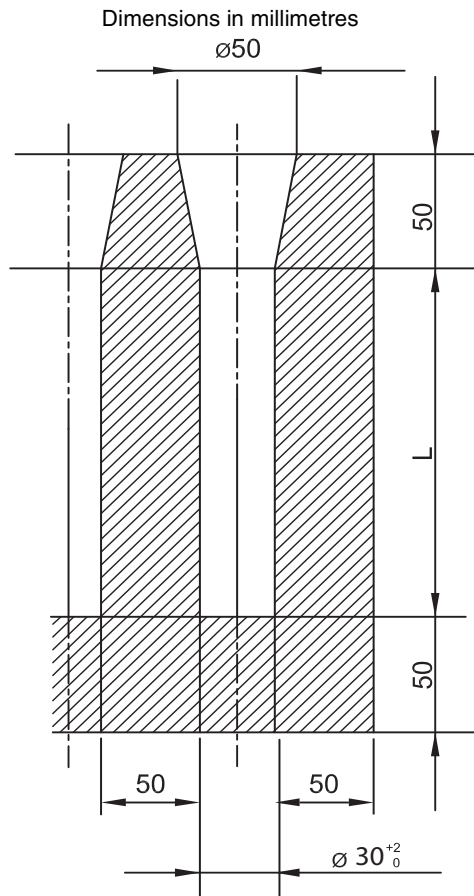

2.2.3 Integrally cast samples may be used when a casting is more than 20 mm thick and its mass exceeds 200 kg, subject to agreement between the Manufacturer and the purchaser. The type and location of the sample are to be selected to provide approximately the same cooling conditions as for the casting it represents.

2.2.4 One tensile test specimen is to be prepared from each test sample. For 30 mm diameter samples, the specimen is to be machined to the dimensions as shown in Ch 1, Sec 2, [2.1.6]. In the case of test samples of other dimensions, the tensile test specimens are to be machined to agreed dimensions.

2.3 Mechanical properties

2.3.1 Only the tensile strength is to be determined and the results obtained from the tests are to comply with the minimum value specified for the castings supplied. The value selected for the specified minimum tensile strength is to be

not lower than 200 N/mm² and not greater than 350 N/mm². In any event it is to be in accordance with any requirements indicated on the approved drawings or in the Rules dealing with the relevant parts.

The fractured surfaces of all tensile test specimens are to be granular, regular and grey in appearance.

2.3.2 Hardness tests may be required in specific cases as a check of homogeneity and are to be performed after the test area has been skinned.

The measured hardness is to be between 160 and 220 Brinell units. Greater hardness may be permissible, however, provided the part remains readily workable.

3 Spheroidal or nodular graphite iron castings

3.1 Application

3.1.1 The requirements of this Article apply to spheroidal or nodular graphite iron castings (SG cast irons) intended for use at ambient temperature.

For other applications, in particular when the castings are intended for service at either low or elevated temperatures, or in the case of severe corrosion, additional requirements and tests may be stipulated.

3.1.2 The general requirements specified in Article [1] are also to be complied with, as appropriate.

3.2 Manufacture and condition of supply

3.2.1 The manufacturing process is to be approved for castings intended for crankshafts.

3.2.2 In addition to the general requirements in [1.8.2], a ferritising heat treatment is to be performed for the special qualities SG 350 and SG 400.

3.3 Test material

3.3.1 The test samples are generally to be one of the standard types detailed in Fig 2, Fig 3 and Fig 4, with a thickness of 25 mm.

However, test samples of other dimensions, as detailed in Fig 2 and Fig 4, may be required in some special cases.

3.3.2 One test sample is to be provided for each casting or batch of castings and, unless otherwise required, may be either gated to the casting or separately cast.

3.3.3 One tensile test specimen is to be prepared from each test sample and machined to the dimensions given in Ch 1, Sec 2.

Figure 2 : Type A test samples (U type)

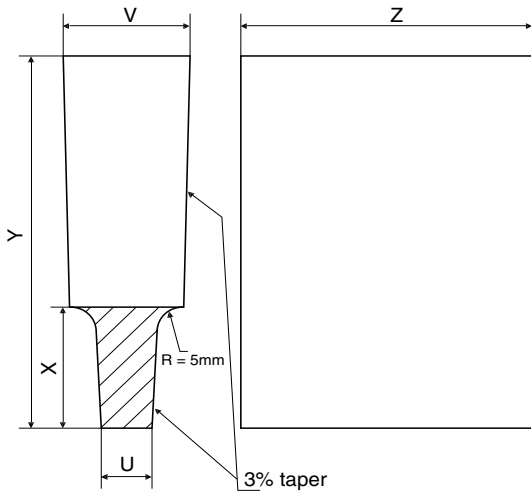

Dimensions:

- u (mm) : 25 (standard sample). 12 or 50 or 75 when specially required
- v (mm) : 55 (standard sample). 40 or 90 or 125 when specially required
- x (mm) : 40 (standard sample). 30 or 60 or 65 when specially required
- y (mm) : 100 (standard sample). 80 or 150 or 165 when specially required
- z : To suit testing machine
- R : Approximately 5 mm.

Figure 3 : Type B test samples (double U type)

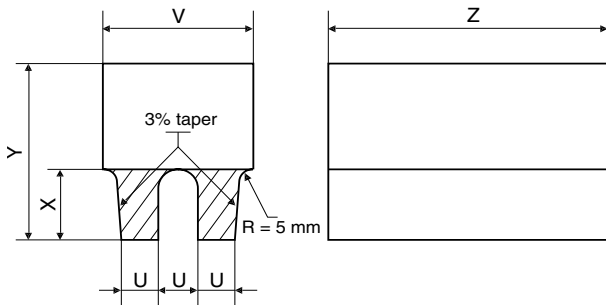

Dimensions:

- u (mm) : 25
- v (mm) : 90
- x (mm) : 40
- y (mm) : 100
- z : To suit testing machine
- R : Approximately 5 mm.

Figure 4 : Type C test samples (Y type)

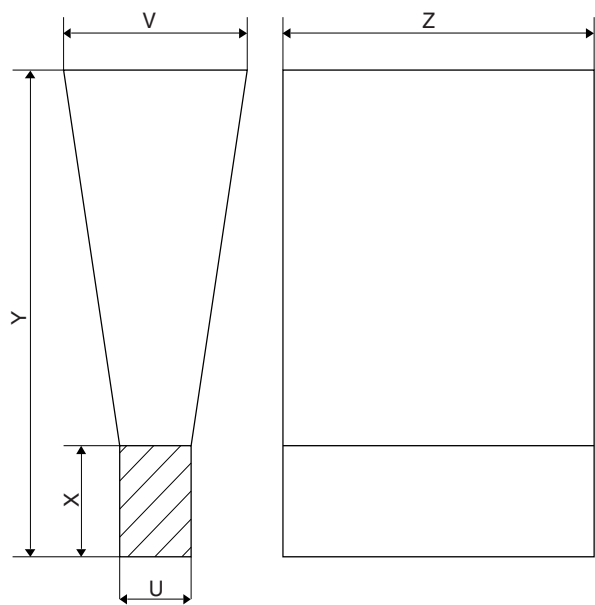

Dimensions:

- u (mm) : 25 (standard sample). 12 or 50 or 75 when specially required
- v (mm) : 55 (standard sample). 40 or 100 or 125 when specially required
- x (mm) : 40 (standard sample). 25 or 50 or 65 when specially required
- y (mm) : 140 (standard sample). 135 or 150 or 175 when specially required
- z,R : To suit testing machine.

3.4 Test and mechanical properties

3.4.1 One tensile test at ambient temperature is to be carried out on each test sample.

If required, a set of three specimens for Charpy V-notch impact tests, is to be prepared from each sample, at ambient temperature.

In particular, the set of impact test specimens is generally to be prepared for castings made in the special qualities SG350S and SG400S spheroidal or nodular.

3.4.2 In the tensile test the ultimate tensile strength and the elongation are to be determined and the results are to comply with the requirements of Tab 1.

Minimum values for the 0,2% yield stress (to be determined only if included in the specification or in the chapter of the Rules related to the concerned part) and typical Brinell hardness values (intended for information only) are also given in Tab 1.

3.5 Metallographic examination

3.5.1 When required for important castings, a representative sample from each ladle of treated metal is to be prepared for metallographic structure examination.

These samples may be taken from the tensile test specimens, or by an alternative procedure agreed with the Surveyor provided they are taken from the ladle they represent towards the end of the casting period.

3.5.2 The metallographic examination is to show that at least 90% of the graphite is in a dispersed or nodular form. Details of typical matrix structures are given in Tab 1 for information purposes only.

3.5.3 The metallographic examination is mandatory for crankshafts.

3.6 Non-destructive examination

3.6.1 In addition to the requirements in [1.5], castings intended for crankshafts are to be submitted to magnetic particle inspection as required at the approval.

Table 1 : Mechanical properties

Qualities	Specified minimum tensile strength R_m (N/mm ²)	Yield strength $R_{p0,2}$ (N/mm ²) min.	Elongation on 5 d (%) (1)	Typical Brinell hardness values	Impact energy		Typical structure of matrix
					Test temp (°C)	KV (J) min (2)	
Ordinary	370	230	17	120 - 180	-	-	Ferrite
	400	250	12	140 - 200	-	-	Ferrite
	500	320	7	170 - 240	-	-	Ferrite/Perlite
	600	370	3	190 - 270	-	-	Ferrite/Perlite
	700	420	2	230 - 300	-	-	Perlite
	800	480	2	250 - 350	-	-	Perlite or Tempered structure
Special	350	220	22 (3)	110 - 170	+20	17 (14)	Ferrite
	400	250	18 (3)	140 - 200	+20	14 (11)	Ferrite

(1) In the case of integrally cast samples, the elongation may be 2 percentage points less.
(2) Average value measured on 3 Charpy V-notch specimens. One result may be below the average value but not lower than the minimum value shown in brackets.
Note 1: For intermediate values of specified minimum tensile strength, the minimum values for 0,2% proof and elongation may be obtained by interpolation.

Part D
Materials and Welding

Chapter 3
NON FERROUS METAL

SECTION 1 COPPER AND COPPER ALLOYS

SECTION 2 ALUMINIUM ALLOYS

SECTION 1

COPPER AND COPPER ALLOYS

1 General

1.1 Application

1.1.1 The requirements of this Section apply in addition to those of Chapter 1 and Chapter 2 to copper or copper alloy tubes and castings.

The requirements for propeller and propeller blade castings are given in Ch 4, Sec 2.

1.1.2 Copper alloys and products other than those indicated in this Section complying with national or international standards or proprietary specifications deemed equivalent to these requirements may be accepted subject to the approval of ^{Tasneef}

1.1.3 Where welding is envisaged, procedures and preparations for the welded joints are to be submitted for approval.

1.2 Manufacture

1.2.1 The manufacturing procedure and heat treatments suitable to obtain products having the required properties are, in principle, left to the discretion of the Manufacturer.

1.2.2 The manufacturing process is to ensure that copper or copper alloy products are free from internal or surface defects which may impair their proper workability and use.

1.3 Testing

1.3.1 Tensile tests required in this Section are to be carried out on cylindrical test specimens of the type defined in Ch 1, Sec 2, [2.1.3] with a gauge length equal to:

$$L_0 = 5,65 \sqrt{S_0} = 5d \text{ (specimen A)}$$

1.4 Documentation and certification

1.4.1 The testing documentation is to contain the information required in Ch 1, Sec 1, [4.2.1].

2 Copper alloy castings

2.1 Application

2.1.1 The requirements of this Article apply to copper alloy castings intended for various uses, with the exception of castings intended for propeller and propeller blades.

2.2 Manufacture

2.2.1 The approval of the manufacturing procedure may be required by ^{Tasneef} on a case-by-case basis for products intended for important uses.

2.3 Condition of supply

2.3.1 Copper alloy castings may be supplied, at the discretion of the Manufacturer, in either the as cast or heat treated condition unless otherwise specified.

2.3.2 When castings are supplied in the heat treated condition, the Manufacturer is to provide the Surveyor with the details of the heat treatment used on the casting.

2.4 Chemical composition

2.4.1 The chemical compositions are to comply with the requirements given in Tab 1.

2.4.2 The Manufacturer is to issue a cast certificate. When castings are made from ingots for which an analysis is already available, and provided that no alloy additions are made, the certified analysis made by the maker of the ingots may be accepted subject to occasional checks as requested by the Surveyor.

2.5 Mechanical properties

2.5.1 Mechanical properties are to comply with the appropriate requirements specified in Tab 2.

2.6 Mechanical tests

2.6.1 Test material sufficient for the required tests and possible re-tests is to be provided for each copper alloy casting.

2.6.2 The batch is to be made by castings from the same heat, and treated in the same furnace charge if delivered in the heat treated condition.

2.6.3 In the case of heat treated material, test samples are to be treated in the same way and, in general, together with the material they represent.

2.6.4 For each test sample, a tensile test specimen is prepared, machined at the dimensions specified in [1.3].

Table 1 : Castings - Chemical composition (%)

Name of alloy	Cu	Sn	Pb	Zn	Fe	Ni	Al	Mn	Si	P	Others
High tensile brass	57/65	≤ 1,0	≤ 0,5	remain- der	0,5/2,0	≤ 3,0	0,5/2,5	0,1/3,0	≤ 0,10		Sb+P+As ≤ 0,40
Leaded bronze	80/87 (1)	4,0/6,0	8,0/11	≤ 2,0	≤ 0,25	≤ 2,0	≤ 0,01	≤ 0,2	≤ 0,01	≤ 0,10	S ≤ 0,10
Phosphor bronze	86/89,5 (1)	9,5/12	≤ 0,5	≤ 0,5	≤ 0,10	≤ 0,2	≤ 0,01	--	≤ 0,02	0,15/1,5	
Bronze Cu Sn10 Zn2 (Gunmetal)	86/89	9,0/11	≤ 1,5	1,0/3,0	≤ 0,25	≤ 2,0	≤ 0,01	≤ 0,2	≤ 0,01	0,05	S ≤ 0,10 Sb ≤ 0,30
Bronze Cu Pb5 Sn5 Zn5 (leaded Gunmetal)	84/86 (1)	4,0/6,0	4,0/6,0	4,0/6,0	≤ 0,30	≤ 2,5	≤ 0,01	--	≤ 0,01	0,05	
Copper- aluminium	88/92 (1)	≤ 0,30	≤ 0,02 (2)	≤ 0,40	2,0/5,0	≤ 3,0	8,5/11	≤ 1,0	≤ 0,20		
Nickel copper aluminium	> 76	≤ 0,20	≤ 0,02 (2)	≤ 0,50	3,5/5,5	3,5/6,5	8,0/11 (4)	≤ 3,0	≤ 0,10		Cu+Fe+Ni+ Al+Mn≥99,2
Copper-nickel 90 / 10	remain- der	--	≤ 0,02 (2)	≤ 0,50 (2)	1,0/1,8	9,0/11	--	0,5/1,0	--	0,20	S ≤ 0,20 (3) C ≤ 0,05
Copper-nickel 70 / 30	remain- der	--	≤ 0,02 (2)	≤ 0,50 (2)	0,4/1,0	29/32	--	0,5/1,5	--	0,20	S ≤ 0,20 C ≤ 0,05

(1) Nickel included.
(2) When no welding is to be done on the pieces, Pb content may be in the range from 0,1% to 0,3%, Zn content may be up to 1,0% and there are no requirements for C, S and P.
(3) Cu + Fe + Mn + Ni +Pb ≥ 99,5%
(4) If this nickel copper aluminium is to withstand sea corrosion, it is necessary that Al ≤ 8,2 + Ni/2

Table 2 : Castings - Mechanical characteristics

Name of Alloy	R _m (N/mm ²)	R _e at 0,2% (N/mm ²) (1)	A (%) on 5d (or 5,65 √S ₀)
High tensile brass	≥ 450	≥ 170	≥ 20
Leaded bronze	≥ 230	≥ 130	≥ 9
Phosphor bronze	≥ 220	≥ 130	≥ 6
Bronze (Gunmetal) Cu Sn10 Zn2	≥ 240	≥ 120	≥ 12
Bronze Cu Pb5 Sn5 Zn5 (leaded Gunmetal)	≥ 200	≥ 90	≥ 13
Copper-aluminium	≥ 450	≥ 160	≥ 15
Nickel copper aluminium	≥ 600	≥ 250	≥ 12
Copper-nickel 90 / 10	≥ 320	≥ 160	≥ 20
Copper-nickel 70 / 30	≥ 420	≥ 220	≥ 20

(1) Values of yield stress at 0,2% offset are indicated for guidance only and, unless specially requested, are not required to be checked during the tensile test.

2.7 Visual and non-destructive examination

2.7.1 All castings are to be cleaned and adequately prepared for inspection.

2.7.2 The Manufacturer is responsible for compliance with dimensions and tolerances.

2.7.3 Before acceptance, all castings are to be presented for visual examination. This is to include the examination of the external and internal surfaces of each casting of the batch and, if necessary, the dye-penetrant test for copper-aluminium and copper-nickel castings.

In addition, for certain copper alloy castings submitted to heavy stresses, the Surveyor may require radiographic and ultrasonic testing.

2.7.4 Unless otherwise indicated in these Rules, copper alloy castings submitted to pressure are to undergo a hydrostatic test at a pressure equal to twice the service pressure.

The Manufacturer is to issue a certificate for these tests and the Surveyor may ask to attend all or part of such tests.

2.8 Rectification of defective castings

2.8.1 The evaluation of defects, where present, and the necessity and the acceptance of the means of rectification are left to the discretion of the Surveyor; to this end, additional checks may be required.

2.8.2 The Surveyor may accept that castings containing local porosities are rectified by impregnation with a suitable plastic filler, provided that the porosities do not adversely affect the mechanical strength of the casting.

2.8.3 Welded repairs are not acceptable, as a rule, unless expressly authorised by the Surveyor.

Any proposal to repair a defective casting by welding is to be previously submitted to the Surveyor, who may require that tests are performed to qualify the proposed welding procedure.

2.9 Identification and marking

2.9.1 The Manufacturer is to adopt a system of identification which will enable all finished castings to be traced to the original cast.

In addition to the indications required in Ch 1, Sec 1, [4.1.3], all castings which have been tested and inspected with satisfactory results are to be marked with the following details:

- a) Manufacturer's name or trade mark
- b) identification number, cast number or other markings which will enable the full history of the casting to be traced
- c) test pressure, where applicable.

2.9.2 Modified arrangements for identification and marking of small castings manufactured in large numbers may be agreed with the Surveyor.

3 Copper alloy pipes

3.1 Application

3.1.1 The requirements of this Article apply to copper alloy pipes intended for condensers, heat exchangers and pressure lines.

3.2 Condition of supply

3.2.1 Copper and copper alloy pipes are to be delivered annealed (recrystallised with fine grain). Copper pipes may also be delivered hard drawn.

3.2.2 Aluminium brass pipes may additionally be required to be given a suitable stress relieving heat treatment when subjected to a cold straightening operation after annealing.

3.3 Chemical composition

3.3.1 The chemical composition of copper alloys used for the manufacture of pipes is to comply with the requirements given in Tab 3 and a corresponding heat certificate is to be issued by the Manufacturer.

3.4 Mechanical properties

3.4.1 The mechanical properties are to comply with the appropriate requirements given in Tab 4.

3.5 Mechanical tests

3.5.1 One series of tests is to be conducted on each batch of 200 pipes coming from the same fabrication and same heat, and having the same size and delivery condition (heat treatment).

3.5.2 At least one length is to be selected at random from each batch for the following tests:

- one tensile test
- one flattening test
- one drift expanding test.

The procedures for mechanical tests and the dimensions of the test specimens are to be in accordance with Ch 1, Sec 2, with the additions and/or modifications as per the present item.

3.5.3 A tensile test is to be carried out on a specimen consisting of a pipe length of full section, or of a strip cut longitudinally in the pipe and of the same thickness as the pipe.

3.5.4 The flattening test consists of slowly flattening a section of pipe 50 mm long by one stroke of a press.

After flattening to a distance between platens equal to three times the thickness of the pipe, no cracking, rupture or defects are to be visible to the unaided eye on the external surface of the pipe.

Table 3 : Pipes - Chemical composition (%)

Name of Alloys	Cu (1)	Sn	Al	Ni (1)	Pb	Fe	Zn	Mn	As	Residual elements
Copper-phosphorus (arsenical or non arsenical)	≥ 99,85								0,30/0,50	P=0,013/0,050 deoxidised
Tin Brass (naval)	70/73	0,9/1,2			≤ 0,07	≤ 0,06	remain- der		0,02/0,06	total impurities +Pb+Fe ≤ 0,3
Aluminium Brass	76/79		1,8/2,5		≤ 0,07	≤ 0,06	remain- der		0,02/0,06	total impurities +Pb+Fe ≤ 0,3
Copper-nickel 90/10 (2)	remain- der			9,0/11	≤ 0,02	1,0/2,0	≤ 0,5	0,3/1,0		C ≤ 0,05-S+P ≤ 0,02 total others ≤ 0,1
Copper-nickel 70/30 (2)	remain- der			29/33	≤ 0,02	0,4/1,0	≤ 0,5	0,5/1,5		C ≤ 0,05-S+P ≤ 0,02 total others ≤ 0,1
Special copper-nickel 70/30 (2)	remain- der	Sn+Pb ≤ 0,05		29/32	≤ 0,02	1,5/2,0	≤ 0,5	1,5/2,0		C ≤ 0,05-S+P ≤ 0,02 total others ≤ 0,1
Copper-Alu 6	≥ 93,0	0,15/0,5	5,0/6,5		≤ 0,02	≤ 1,0	≤ 0,3			total impurities ≤ 0,5

(1) Silver is considered as copper; cobalt as nickel.
(2) When no welding is to be done on copper-nickel pipes, there are no requirements regarding P, S and C, and the Zn content may be up to 1%, the Pb content up to 0,05%.

Table 4 : Pipes - Mechanical properties

Name of Alloy	R _m (N/mm ²)	R _{e0,2} (N/mm ²)	A (%) on 5,65 √S ₀
Copper-phosphorus (arsenical or non arsenical) (1)	≥ 220 ≥ 230 ≥ 270	≥ 100 ≥ 155 for guidance	≥ 35 (annealed) ≥ 20 (quarter-hard temper) ≥ 10 (half-hard temper)
Tin Brass	≥ 310	≥ 105	≥ 35
Aluminium Brass	≥ 345	≥ 125	≥ 35
Copper-nickel 90/10	≥ 290	≥ 105	≥ 30
Copper-nickel 70/30	≥ 360	≥ 125	≥ 30
Special copper-nickel 70/30	≥ 420	≥ 125	≥ 30
Copper-Alu 6	≥ 345	≥ 130	≥ 40

(1) In the case of copper-phosphorus, the tensile test may be replaced by the HV hardness test when this is specified in certain national standards.

3.5.5 The drift expanding test consists of expanding a section of pipe between 30 mm and 50 mm in length until the external diameter is increased by 20% (15% for halfhard pipes), at ambient temperature, by means of a tapered pin having a 45° included angle.

No cracking or rupture is to be visible to the unaided eye after completion of tests.

3.6 Stress corrosion cracking test

3.6.1 The stress corrosion test (Hg-nitrate test) is designed to reveal the presence of residual stresses which could lead to stress corrosion cracks.

The test consists of immersing for 30 minutes a 150 mm specimen in a water solution with the required Hg-nitrate concentration after proper cleaning.

The water solution is to contain 10gr of mercurous nitrate and 10 cm³ of nitric acid (specific gravity 1,41) per litre of solution. The specimen is then to be immediately washed, rinsed and inspected.

No signs of cracking are to appear within eight days following the immersion.

3.6.2 The test may be carried out in accordance with an acceptable national standard using a mercurous nitrate solution.

3.6.3 Should any specimen fail to meet the requirements of this test, then all tubes represented by that specimen are to be rejected but may be resubmitted after a stress relieving treatment.

3.7 Hydrostatic test - Eddy current test

3.7.1 All pipes are to be tested to a pressure equal to 1,5 times their design service pressure without exceeding 6,90 MPa, unless otherwise specified.

3.7.2 If the service pressure is unknown at the time of the hydrostatic test, a test pressure calculated according to the following formula may be applied :

$$P = \frac{0,5 \cdot t \cdot R_m}{D}$$

P : Test pressure, in MPa

t : Nominal wall thickness, in mm

D : Nominal outside diameter, in mm

R_m : Minimum guaranteed tensile strength, in N/mm², according to Tab 4.

3.7.3 The test pressure is to be maintained for sufficient time to permit proof and inspection. There is to be no evidence of leakage or sweating.

3.7.4 An Eddy current test may be accepted in lieu of the hydrostatic test.

3.7.5 The Eddy current testing facilities are to be submitted to special approval with particular attention to the calibrating conditions of the equipment used; it is to be demonstrated that testing with Eddy currents as proposed is at least as rigorous as the hydrostatic test.

3.7.6 The Surveyor may need to check that the equipment used is calibrated.

3.7.7 Unless otherwise agreed, the Manufacturer's certificate of satisfactory hydraulic or Eddy current testing will be accepted.

3.8 Visual and non-destructive examination

3.8.1 The Manufacturer is to prepare a report relative to the inspection and verification of dimensions of all of the tubes presented.

The dimensional tolerances (diameter, thickness) are to comply with applicable national standards.

3.8.2 The Surveyor may require that all pipes are presented for visual examination and verification of dimensions.

Internal and external surfaces of pipes are to have a clean and smooth finish, and be free from harmful defects.

The Manufacturer is to provide adequate equipment to enable an internal and external examination of the pipes to be carried out

3.9 Rectification of defects

3.9.1 Small surface imperfections may be removed by grinding provided that the thickness of the pipe after grinding and dressing is not less than the required minimum thickness. The dressed areas are to be blended into the contour of the tube with very large radius fillets.

3.9.2 Repair of defects by welding is not permitted; thus any defects which cannot be removed by grinding will necessarily lead to the rejection of the pipe.

3.10 Identification and marking

3.10.1 All pipes and tubes are to be identified and marked in conformity with the requirements of Ch 1, Sec 1, [4.1.3]. The following additional details are to be shown on all materials which have been accepted:

- a) Manufacturer's name or trade mark
- b) grade of material or designation code.

3.10.2 Identification is to be by rubber stamp or stencils. Hard stamping is not permitted.

SECTION 2

ALUMINIUM ALLOYS

1 General

1.1 Application

1.1.1 General

The requirements of this Section apply to wrought aluminium alloys, rivets, transition joints and cast aluminium alloys.

1.1.2 Other standards

Alloys and tempers other than those defined in Articles [2], [3], [4] and [5], and which comply with national or international standards or proprietary specifications deemed equivalent to these requirements, may be accepted with the agreement of ^{Tasneef}

1.1.3 Weldability

Except for rivets, aluminium products in accordance with these Rules are weldable using suitable welding processes and, where appropriate, subject to any conditions stated at the time of approval.

1.2 Manufacture

1.2.1 Manufacturing process

Manufacturing processes and heat treatments suitable to obtain products having the specified quality and properties are, in principle, left to the discretion of the Manufacturer.

Heat treatment is to be carried out in suitable furnaces fitted with the necessary equipment, in accordance with appropriate procedures, to the satisfaction of the Surveyor.

1.2.2 Approval

The manufacturing and treatment processes and the control systems are to be approved by ^{Tasneef} for individual Manufacturers. To this end, detailed information is to be submitted to ^{Tasneef} and, as a rule, checks and tests are required depending on the importance of the product and its intended use.

1.2.3 Quality of material

All products are to have a workmanlike finish and be free from defects, surface or internal imperfections, segregation and non-metallic inclusions which may impair their proper workability and use.

1.2.4 Identification

The Manufacturer is to adopt a system of identification which will ensure that all finished material in a batch presented for testing is of the same nominal chemical composition.

1.2.5 Marking

Products are to be clearly marked by the Manufacturer in accordance with the requirements of Chapter 1.

The following details are to be shown on all materials which have been accepted:

- Manufacturer's mark
- grade of alloy and temper conditions
- number of the manufacturing batch enabling the manufacturing process to be traced
- Classification Society's brand.

When extruded products are bundled together or packed in crates for delivery, the marking is to be affixed by a securely fastened tag or label.

1.2.6 Certification and documentation

Each test certificate or shipping statement is to include the following particulars:

- purchaser's name and order number
- description and dimensions
- specification or grade of alloy
- details of heat treatment, where applicable
- identification mark which will enable the full history of the item to be traced
- chemical composition
- mechanical test results (not required on shipping statement).

Where the alloy is not produced at the works at which it is wrought, a certificate is to be supplied by the Manufacturer of the alloy stating the cast number and chemical composition. The works at which the alloy was produced is to be approved by ^{Tasneef}

2 Wrought aluminium alloy products (plates, bars, sections and tubes)

2.1 Application

2.1.1 The requirements of this Article apply to wrought aluminium alloys used in the construction of hulls and other marine structures, and for cryogenic applications.

2.1.2 These requirements are applicable to wrought aluminium products within a thickness range between 3 mm and 50 mm inclusive.

2.1.3 The application of these provisions to aluminium alloy products outside this thickness range requires the prior agreement of ^{Tasneef}

The general requirements specified in Article [1] are also to be complied with, as appropriate.

2.1.4 In the case of ships carrying liquefied gas in bulk, the International Code for the Construction and Equipment of Ships Carrying Liquefied Gases in Bulk also applies.

Materials intended for the construction of cargo tanks or storage tanks for liquefied gases and for other low temperature applications are to be manufactured in 5083 alloy in the annealed condition.

2.2 Aluminium grades

2.2.1 Designation

The numerical designation (grade) of aluminium alloys and their temper designation are in accordance with the "Registration Record of International Alloy Designation".

Temper conditions (delivery heat treatment) are defined in EN 515 or ANSI H35.1.

2.2.2 Rolled products (sheets, strips and plates)

The following aluminium alloys are covered by these requirements:

- 5083
- 5059
- 5086
- 5383
- 5456
- 5754

with the following temper conditions:

- O/H111/H112
- H116
- H321

2.2.3 Extruded products (sections, shapes, bars and closed profiles)

The following aluminium alloys are covered by these requirements:

- 5083
- 5059
- 5086
- 5383

with the following temper conditions:

- O/H111/H112

and

- 6005A
- 6061
- 6082

with the following temper conditions:

- T5 or T6

The alloy grades 6005A and 6061 of the 6000 series are not to be used in direct contact with sea water unless protected by anodes and/or a paint system.

2.3 Manufacture

2.3.1 Approval

All materials, including semi-finished products, are to be manufactured at works which are approved by ^{Tasneef} for the grades of aluminium alloy supplied ([1.2.2]).

Plates are to be formed by rolling and may be hot or cold finished.

Bars and sections may be formed by extrusion, rolling or drawing.

2.3.2 Quality of materials

It is the producer's responsibility to check the quality of the materials as well as conformity with dimensional tolerances.

2.3.3 Repairs

Slight surface imperfections may be removed by grinding or machining provided the thickness of the material remains everywhere within acceptable tolerances.

The repair of defects by welding is not accepted.

2.3.4 Dimensional tolerances

The under thickness tolerances for rolled products given in Tab 1 are minimum requirements.

The underthickness tolerances for extruded products are to be in accordance with the requirements of recognised international or national standards.

Dimensional tolerances other than under thickness tolerances are to comply with a recognised national or international standard.

2.3.5 Non-destructive examination

In general, the non-destructive examination of material is not required for acceptance purposes.

Table 1 : Under thickness tolerances for rolled products

Nominal thickness (mm)	Thickness tolerances for nominal width (mm)		
	up to 1500	from 1500 to 2000	from 2000 to 3500
from 3 to 4	0,10	0,15	0,15
from 4 to 8	0,20	0,20	0,25
from 8 to 12	0,25	0,25	0,25
from 12 to 20	0,35	0,40	0,50
from 20 to 50	0,45	0,50	0,65

2.4 Chemical composition

2.4.1 The Manufacturer is to determine the chemical composition of each cast.

2.4.2 The chemical composition of aluminium alloys is to comply with the requirements given in Tab 2.

The Manufacturer's declared analysis is accepted subject to occasional checking if required by the Surveyor; in particular, product analysis may be required where the final product chemistry is not well represented by the analysis from the cast.

2.4.3 When the aluminium alloys are not cast in the same works in which they are manufactured into semi-finished products, the Surveyor is to be given a certificate issued by the works in question indicating the reference numbers and chemical composition of the heats.

2.5 Corrosion testing

2.5.1 Rolled 5xxx-alloys of type 5083, 5383, 5059, 5086 and 5456 in the H116 and H321 tempers intended for use in marine hull construction or in marine applications where frequent direct contact with seawater is expected are to be corrosion tested with respect to exfoliation and intergranular corrosion resistance.

2.5.2 The Manufacturers are to establish the relationship between microstructure and resistance to corrosion when the alloys as per [2.5.1] are approved. A reference photomicrograph taken at 500x, is to be established for each of the alloy-tempers and thickness ranges relevant. The reference photographs are to be taken from samples which have exhibited no evidence of exfoliation corrosion and a pitting rating of PB or better, when subjected to the test described in ASTM G66 (ASSET). The samples are also to have exhibited resistance to intergranular corrosion at a mass loss no greater than 15mg/cm², when subjected to the test described in ASTM G67. Upon satisfactory establishment of the relationship between microstructure and resistance to corrosion, the master photomicrographs and the results of the corrosion tests are to be approved by Tasneef Production practices are not to be changed after approval of the reference micrographs.

Other test methods may also be accepted at the discretion of Tasneef

2.5.3 For batch acceptance of 5xxx-alloys in the H116 and H321 tempers, metallographic examination of one sample selected from mid width at one end of a coil or random sheet or plate is to be carried out. The microstructure of the

sample is to be compared to the reference photomicrograph of acceptable material in the presence of the Surveyor. A longitudinal section perpendicular to the rolled surface is to be prepared for metallographic examination. If the microstructure shows evidence of continuous grain boundary network of aluminium-magnesium precipitate in excess of the reference photomicrographs of acceptable material, the batch is either to be rejected or tested for exfoliation-corrosion resistance and intergranular corrosion resistance subject to the agreement of the Surveyor. The corrosion tests are to be in accordance with ASTM G66 and G67 or equivalent standards. If the results from testing satisfy the acceptance criteria stated in 2.5.2 the batch is accepted, otherwise, it is to be rejected.

As an alternative to metallographic examination, each batch may be tested for exfoliation corrosion resistance and intergranular corrosion resistance, in accordance with ASTM G66 and G67 or equivalent standards.

2.5.4 Tempers that are corrosion tested are to be marked "M" after the temper condition, e.g. 5083 H321M.

2.6 Mechanical properties

2.6.1 Mechanical properties are specified in Tab 3 and Tab 4.

2.7 Mechanical tests

2.7.1 General

Test specimens for mechanical tests and procedures are to be selected in accordance with Chapter 1 or national or international requirements relative to the wrought aluminium alloy materials concerned.

The Manufacturer is to demonstrate by macro-section tests or drift expansion tests of closed profiles performed on each batch of closed profiles that there is no lack of fusion at the press welds.

Once cut and machined, test materials are not to be submitted to any heat or mechanical treatment.

2.7.2 Batch composition

Each batch is made of products:

- a) of the same alloy grade and from the same cast
- b) of the same product form and of similar dimensions (for plates: same thickness)
- c) manufactured by the same process
- d) having been submitted simultaneously to the same temper condition.

2.7.3 Sampling

Tests samples are to be taken:

- at one third of the width from a longitudinal edge of rolled products
- in the range from 1/3 to 1/2 of the distance from the edge to the centre of the thickest part of extruded products.

Test samples are to be taken so that the orientation of test specimens is as follows:

- Rolled products (plates, sheets)

Normally, tests in the transverse direction are required. If the width is insufficient to obtain trans-

verse test specimens, or in the case of strain hardening alloys, tests in the longitudinal direction may be permitted.

- Extruded products

Extruded products or extruded drawn materials (pipes, bars, miscellaneous sections) are tested in the longitudinal direction.

After removal of test samples, each test specimen is to be marked so that its original identity, location and orientation are maintained.

Table 2 : Chemical composition

Grade	Chemical composition (%) (1)									
	Si	Fe	Cu	Mn	Mg	Cr	Zn	Ti	Other elements (2)	
									Each	Total
5083	0,40	0,40	0,10	0,40-1,0	4,0-4,9	0,05-0,25	0,25	0,15	0,05	0,15
5383	0,25	0,25	0,20	0,7-1,0	4,0-5,2	0,25	0,40	0,15	0,05 (5)	0,15 (5)
5059	0,45	0,50	0,25	0,6-1,2	5,0-6,0	0,25	0,40-0,90	0,20	0,05 (6)	0,15 (6)
5086	0,40	0,50	0,10	0,20- 0,7	3,5-4,5	0,05-0,25	0,25	0,15	0,05	0,15
5754	0,40	0,40	0,10	0,50 (3)	2,6-3,6	0,30 (3)	0,20	0,15	0,05	0,15
5456	0,25	0,40	0,10	0,50-1,0	4,7-5,5	0,05-0,20	0,25	0,20	0,05	0,15
6005A	0,50-0,9	0,35	0,30	0,50 (4)	0,40-0,7	0,30 (4)	0,20	0,10	0,05	0,15
6061	0,40-0,8	0,7	0,15-0,40	0,15	0,8-1,2	0,04-0,35	0,25	0,15	0,05	0,15
6082	0,7-1,3	0,50	0,10	0,40-1,0	0,6-1,2	0,25	0,20	0,10	0,05	0,15

(1) Chemical composition in percentage mass by mass maximum unless shown as a range or as a minimum.
(2) Includes Ni, Ga, V and listed elements for which no specific limit is shown. Regular analysis need not be made.
(3) Mn + Cr: 0,10-0,60
(4) Mn + Cr: 0,12-0,50
(5) Zr: maximum 0,20. The total for other elements does not include Zirconium.
(6) Zr: 0,05-0,25. The total for other elements does not include Zirconium.

Table 3 : Mechanical properties for rolled products, 3 mm ≤ t ≤ 50 mm

Grade	Temper condition	Thickness, t	Yield Strength $R_{p0,2}$ min. or range (N/mm ²)	Tensile Strength R_m min or range (N/mm ²)	Elongation, % min. (1)	
					A ₅₀ mm	A _{5d}
5083	0	3 ≤ t ≤ 50 mm	125	275-350	16	15
	H111	3 ≤ t ≤ 50 mm	125	275 - 350	16	15
	H112	3 ≤ t ≤ 50 mm	125	275	12	10
	H116	3 ≤ t ≤ 50 mm	215	305	12	10
	H321	3 ≤ t ≤ 50 mm	215 - 295	305 - 385	12 (2)	10
5383	0	3 ≤ t ≤ 50 mm	145	290		17
	H111	3 ≤ t ≤ 50 mm	145	290		17
	H116	3 ≤ t ≤ 50 mm	220	305	12 (2)	10
	H321	3 ≤ t ≤ 50 mm	220	305	10	10
5059	0	3 ≤ t ≤ 50 mm	160	330		24
	H111	3 ≤ t ≤ 50 mm	160	330		24
	H116	3 ≤ t ≤ 20 mm	270	370	10	10
		20 ≤ t ≤ 50 mm	260	360	10	10
	H321	3 ≤ t ≤ 20 mm	270	370	10	10
		20 ≤ t ≤ 50 mm	260	360	10	10
5086	0	3 ≤ t ≤ 50 mm	95	240-305	16	14
	H111	3 ≤ t ≤ 50 mm	100	240 - 310	17 (3)	16
	H112	3 ≤ t ≤ 12,5 mm	125	250	8	
		12,5 ≤ t ≤ 50 mm	105	240		9
	H116	3 ≤ t ≤ 50 mm	195	275	10 (4)	9
	H321	3 ≤ t ≤ 50 mm	185	275 - 335	10 (4)	9
5754	0	3 ≤ t ≤ 50 mm	80	190-240	18	17
	H111	3 ≤ t ≤ 50 mm	80	190-240	18	17
5456	0	3 ≤ t ≤ 6,3 mm	130 - 205	290 - 365	16	
		6,3 ≤ t ≤ 50 mm	125 - 205	285 - 360	16	14
	H116	3 ≤ t ≤ 30 mm	230	315	10	10
		30 ≤ t ≤ 40 mm	215	305		10
		40 ≤ t ≤ 50 mm	200	285		10
	H321	3 ≤ t ≤ 12,5 mm	230 - 315	315 - 405	12	
		12,5 ≤ t ≤ 40 mm	215 - 305	305 - 385		10
		40 ≤ t ≤ 50 mm	200 - 295	285 - 370		10

(1) Elongation in 50 mm applies for thicknesses up to and including 12,5 mm and in 5d for thicknesses over 12,5 mm.
(2) 10 % for thicknesses up to and including 6,0 mm.
(3) 15 % for thicknesses up to and including 6,0 mm.
(4) 8 % for thicknesses up to and including 6,0 mm.

2.7.4 Type and location of tensile test specimen

A flat tensile test specimen is to be used for specified thicknesses up to and including 12,5mm.

The tensile test specimen is to be prepared so that both rolled surfaces are maintained.

For thicknesses exceeding 12,5mm, a round tensile test specimen is to be used.

For thicknesses up to and including 40mm, the longitudinal axis of the round tensile test specimen is to be located at a distance from the surface equal to half of the thickness.

For thicknesses over 40mm, the longitudinal axis of the round tensile test specimen is to be located at a distance from one of the surfaces equal to one quarter of the thickness.

For pipes equal to or less than 40mm in diameter: the test specimen consists of a section of the tube itself.

For pipes more than 40mm in diameter: the test specimen consists of a part of the tube sectional area only.

Table 4 : Mechanical properties for extruded products, $3 \text{ mm} \leq t \leq 50 \text{ mm}$

Grade	Temper condition	Thickness, t	Yield Strength $R_{p0,2}$ min. or range (N/mm ²)	Tensile Strength R_m min or range (N/mm ²)	Elongation, % min. (1) (2)	
					$A_{50 \text{ mm}}$	A_{5d}
5083	0	$3 \leq t \leq 50 \text{ mm}$	110	270 - 350	14	12
	H111	$3 \leq t \leq 50 \text{ mm}$	165	275	12	10
	H112	$3 \leq t \leq 50 \text{ mm}$	125	270	12	10
5383	0	$3 \leq t \leq 50 \text{ mm}$	145	290	17	17
	H111	$3 \leq t \leq 50 \text{ mm}$	145	290	17	17
	H112	$3 \leq t \leq 50 \text{ mm}$	190	310		13
5059	H112	$3 \leq t \leq 50 \text{ mm}$	200	330		10
5086	0	$3 \leq t \leq 50 \text{ mm}$	95	240 - 320	18	15
	H111	$3 \leq t \leq 50 \text{ mm}$	145	250	12	10
	H112	$3 \leq t \leq 50 \text{ mm}$	95	240	12	10
6005A	T5	$3 \leq t \leq 50 \text{ mm}$	215	260	9	8
	T6	$3 \leq t \leq 10 \text{ mm}$	215	260	8	6
		$10 < t \leq 50 \text{ mm}$	200	260	8	6
6061	T6	$3 \leq t \leq 50 \text{ mm}$	240	260	10	8
6082	T5	$3 \leq t \leq 50 \text{ mm}$	230	270	8	6
	T6	$3 \leq t \leq 5 \text{ mm}$	250	290	8	
		$5 < t \leq 50 \text{ mm}$	260	310	10	8

(1) The values are also applicable for longitudinal and transverse tensile test specimens.

(2) Elongation in 50 mm applies for thicknesses up to and including 12,5 mm and in 5d for thicknesses over 12,5 mm.

2.8 Testing

2.8.1 Tensile test

a) Rolled products

One tensile test specimen is to be taken from each batch of the product. If the weight of one batch exceeds 2000 kg, one extra tensile test specimen is to be taken from every 2000 kg of the product or fraction thereof, in each batch.

For single plates or for coils weighing more than 2000kg each, one tensile test specimen per plate or coil only is to be taken.

For plates to be used in the construction of cargo tanks, secondary barriers and process pressure vessels with design temperatures below -55°C, a tensile test is required from each plate.

b) Extruded products

For products with a nominal weight of less than 1kg/m, one tensile test specimen is to be taken from each 1000 kg, or fraction thereof, in each batch. For nominal weights between 1 and 5 kg/m, one tensile test is to be taken from each 2000 kg or fraction thereof, in each batch. If the nominal weight exceeds 5kg/m, one tensile test specimen is to be taken for each 3000 kg of the product or fraction thereof, in each batch.

For pipes, one test sample from each batch is to be taken.

Batches are to be made up of no more than 50 tubes of the same diameter and wall thickness, manufactured from the same cast with the same final condition or heat treatment.

At the discretion of the Surveyor, tubes having slightly different diameters and/or thicknesses may be included in the same batch.

2.8.2 Verification of proper fusion of press welds

For press welded closed profiles, verification of proper fusion of press welds by macro section or drift expansion tests is to be performed on each batch.

2.8.3 Drift expansion tests

- a) Every fifth profile is to be sampled after final heat treatment. For batches of five profiles or less, one profile is to be sampled. Profiles with lengths exceeding 6 m are to be sampled every profile at the start of the production. The number of tests may be reduced to every fifth profile if the results from the first 3-5 profiles are found to be acceptable.
- b) Each profile sampled is to have two samples cut from the front and back end of the production profile.
- c) The test specimens are to be cut with the ends perpendicular to the axis of the profile. The edges of the end may be rounded by filing.
- d) The length of the specimen is to be in accordance with Ch 1, Sec 2, [7.2].
- e) Testing is to be carried out at ambient temperature and is to consist of expanding the end of the profile by

means of a hardened conical steel mandrel having an included angle of at least 60°.

- f) The sample is considered to be unacceptable if it fails with a clean split along the weld line which confirms lack of fusion.

2.8.4 Corrosion tests

For rolled plates of grade 5083, 5383, 5059, 5086 and 5456 delivered in the tempers H116 or H321, one sample is to be tested per batch.

2.9 Re-test procedures

2.9.1 When the tensile test from the first piece selected in accordance with [2.8.1] fails to meet the requirements, two further tensile tests may be made from the same piece. If both of these additional tests are satisfactory, this piece and the remaining pieces from the same batch may be accepted.

2.9.2 If one or both of the additional tests referred to in [2.9.1] is/are unsatisfactory, the piece is to be rejected, but the remaining material from the same batch may be accepted, provided that two of the remaining pieces in the batch selected in the same way are tested with satisfactory results.

If unsatisfactory results are obtained from either of these two pieces, then the batch of material is rejected.

2.9.3 In the event of any material bearing Tasneef brand failing to comply with the test requirements, the brand is to be unmistakably defaced by the Manufacturer.

2.10 Hydrostatic test

2.10.1 Pipes intended for pressure parts are to be subjected to hydrostatic testing.

Unless otherwise required, the test pressure is to be at least 1,5 times the maximum working pressure.

2.11 Visual and non-destructive examination

2.11.1 Surface inspection and verification of dimensions are the responsibility of the Manufacturer.

Unless otherwise agreed, the following products are to be submitted to the Surveyor for visual examination:

- plates for the construction of cargo tanks, secondary barriers and process pressure vessels
- pressure pipes.

2.11.2 In general non-destructive tests of materials are not required for acceptance purposes. However, such tests may be required for specific applications, or by the Surveyor as an additional check.

3 Rivets

3.1 Application

3.1.1 Generality

The requirements of this Article apply to aluminium alloy rivets intended for use in the construction of marine structures.

3.2 Chemical composition and heat treatment

3.2.1 For rivets or rivet bars which are made up of magnesium alloys, the magnesium content is not to exceed a maximum of 3,9%.

In particular, the chemical composition of bars used for the manufacture of rivets is to comply with the requirements of Tab 5.

Table 5 : Chemical composition, percentage

Element	5154A	6082
Copper	0,10 max	0,10 max
Magnesium	3,10 - 3,90	0,60 - 1,20
Silicon	0,50 max	0,70 - 1,30
Iron	0,50 max	0,50 max
Manganese	0,10 - 0,50	0,40 - 1,00
Zinc	0,20 max	0,20 max
Chromium	0,25 max	0,25 max
Titanium	0,20 max	0,10 max
Other elements: each	0,05 max	0,05 max
total	0,15 max	0,15 max
Aluminium	remainder	remainder

3.3 Heat treatment

3.3.1 Rivets are to be supplied in the following conditions:

5154A - annealed

6082 - solution treated.

3.4 Test material

3.4.1 Bars intended for the manufacture of rivets are to be presented for testing in batches of no more than 250 kg.

The material in each batch is to be of the same alloy, manufacturing process and final heat treatment and have the same or a comparable diameter. One test sample is to be taken from each batch and, prior to testing, heat treated in full cross-section and in a manner simulating the heat treatment applied to the finished rivets.

3.5 Mechanical tests

3.5.1 At least one tensile specimen and one flattening test specimen are to be prepared from each test sample.

3.5.2 The tensile test specimen is to be a short length of bar having the original diameter of the product.

3.5.3 The flattening test consists of compressing the specimen between two rigid and parallel flat plates in a direction perpendicular to its longitudinal axis; the plates are to cover the whole specimen after flattening.

The flattening test specimen is to consist of a full section of bar having the original diameter of the product and a length of 1,5 times the diameter cut from the bar.

The test is to be continued until the distance between the two plates, measured under load, reaches a value corresponding to one half of the original length of the specimen.

The test is to be performed at ambient temperature.

The result of the test is satisfactory if, after compression, the specimen is free from cracks.

3.5.4 The results of tensile tests are to comply with the appropriate requirements of Tab 6.

Table 6 : Mechanical properties

Mechanical properties	5154A	6082
0,2% proof stress (N/mm ²) min	90	120
Tensile strength (N/mm ²) min	220	190
Elongation (%) on 5, 65 $\sqrt{S_0}$ min	18	16

3.5.5 At least three samples are to be selected from each consignment of manufactured rivets. Flattening tests as detailed in [3.5.3] are to be carried out on each sample.

3.6 Identification

3.6.1 Each package of manufactured rivets is to be identified with attached labels giving the following details:

- Manufacturer's name or trade mark
- alloy grade
- rivet size.

3.7 Certification

3.7.1 The test certificate for each consignment of manufactured rivets is to include the following particulars:

- purchaser's name and order number
- description and dimensions
- specification of the alloy.

4 Transition joints

4.1 General

4.1.1 The requirements of this Article apply to explosion bonded composite aluminium/steel transition joints used for the connection of aluminium structures to steel plating.

4.2 Manufacture

4.2.1 Transition joints are to be manufactured at works which are approved by Tasneef. The specification of the Manufacturer is to be submitted for approval. The maximum temperature allowable at the interface during welding is to be indicated; approval tests are required.

4.2.2 The aluminium material is to comply with the requirements of [2] and the steel is to be of an appropriate grade complying with the requirements of Ch 2, Sec 1.

4.3 Visual and non-destructive examination

4.3.1 Each composite plate is to be subjected to 100% visual and ultrasonic examination in accordance with a relevant national standard to determine the extent of any unbonded areas. The latter are unacceptable and any such area plus 25 mm of surrounding sound material is to be discarded.

4.4 Inspection

4.4.1 The series of tests includes, from each end of one plate in a batch of three plates:

- one through thickness tensile test
- one shear test
- one bend test.

4.4.2 Tests are made on specimens equivalent to those specified at the approval.

The results of these tests are to comply with the requirements of the manufacturing specification.

5 Aluminium alloy castings

5.1 General

5.1.1 The requirements of this Article apply to aluminium alloy castings used in the construction of hulls and other marine structures, and for cryogenic applications where the design temperature is not lower than -165°C.

5.2 Aluminium grades

5.2.1 Alloy castings may be manufactured with magnesium, silicon or magnesium-silicon alloys as follows:

- a) magnesium alloys: Al-Mg 3 and Al-Mg 6
- b) silicon alloys: Al-Si 12
- c) magnesium-silicon alloys: Al-Si 7 Mg 0,3; Al-Si 7 Mg 0,6; Al-Si 10 Mg; and possibly: Al-Si 2 Mg.

5.2.2 Alloys Al-Mg 3, Al-Mg 6 and Al-Si 12 are not generally submitted to heat treatment after casting; this is not the case for magnesium-silicon alloys which may undergo such treatment.

5.2.3 The use of other alloys or of alloys which have been submitted to a specific heat treatment is subject to Tasneef agreement.

5.3 Manufacture

5.3.1 Approval

Alloy castings are to be manufactured at works which are approved by Tasneef for the grade of aluminium alloy supplied.

5.3.2 Quality of castings

All castings are to be free from surface or internal defects which would be prejudicial to their proper application in service.

5.3.3 Visual examination

All castings are to be cleaned and adequately prepared for inspection.

The visual examination and verification of dimensions are the responsibility of the Manufacturer, unless otherwise agreed.

Before acceptance, all castings are to be presented to the Surveyor for visual examination, unless otherwise agreed with him.

5.3.4 Non-destructive tests

If non-destructive tests are required, the procedures are to be examined by Tasneef

5.3.5 Repairs

At the discretion of the Surveyor, small surface defects may be removed by grinding.

Where repairs by welding are necessary, the welding procedure is to be preliminarily approved by Tasneef which will state the tests and checks deemed necessary.

The agreed repairs are then to be surveyed as required.

5.3.6 Pressure testing

Where required by the relevant construction Rules, casting are to be pressure tested before final acceptance.

Unless otherwise agreed, these tests are to be carried out in the presence and to the satisfaction of the Surveyor.

5.4 Chemical composition

5.4.1 The chemical composition of aluminium alloys used to manufacture castings is given in Tab 7 and the relevant certificate is to be provided by the producer.

5.5 Mechanical properties

5.5.1 The mechanical properties are given in Tab 8.

5.5.2 The mechanical properties given in Tab 8 correspond to the non-heat treated condition. However, the test pieces may be heat-treated.

In the case of heat treatment, test samples are to be treated in the same way and, as a rule, together with the material they represent.

Generally, only tensile strength and elongation values are rule requirements; the values of yield stress are given for information.

5.6 Mechanical tests

5.6.1 At least one tensile specimen is to be tested from each batch.

Batches are to have a total mass not exceeding 500kg and be made up of pieces having the same or comparable shape and dimensions, manufactured from the same cast with the same condition of heat treatment.

The number of pieces in each batch is not to exceed 25 in the case of castings for pistons and for pressure parts or

pieces of considerable importance; a greater number may be accepted for small pieces, to the Surveyor's satisfaction.

The homogeneity of batches of aluminium alloy castings may be checked by means of a Brinell type hardness test when small castings manufactured in large quantities are concerned.

5.6.2 The test samples are to be separately cast in moulds made from the same type of material as used for the castings. These moulds are to conform to national standards, as appropriate.

5.6.3 The method and procedures for the identification of the test specimens, and the casting they represent, are to be agreed with the Surveyor. The identification marks are to be maintained during the preparation of test specimens.

5.6.4 Where the results of a test do not comply with the requirements, the re-test procedure detailed in Chapter 1 is to be applied. When castings are to be used in the heat treated condition, the re-test sample is also to be heat treated together with the castings it represents.

Table 7 : Aluminium alloy castings - Chemical composition (see Note 1)

Designation ISO		Si (%)	Fe (%)	Cu (%)	Mn (%)	Mg (%)	Ni (%)	Zn (%)	Pb (%)	Sn (%)	Ti (%)	Others (%) each total	
Al-Mg 3	Mini	0,50	0,50	0,10	0,50	2,50	0,05	0,20	0,05	0,05	0,05	0,05	0,15
	Maxi					3,50					0,25		
Al-Mg 6 (1)	Mini	0,40	0,50	0,10	0,50	5,00	0,05	0,20	0,05	0,05	0,20	0,05	0,15
	Maxi					7,00							
Al-Si 2 Mg	Mini	1,60	0,60	0,10	0,30	0,45	0,05	0,10	0,05	0,05	0,05	0,05	0,15
	Maxi	2,40			0,50	0,65					0,20		
Al-Si 7 Mg (2)	Mini	6,50	0,55	0,15	0,50	0,20	0,05	0,10	0,05	0,05	0,05	0,05	0,15
	Maxi	7,50				0,40					0,25		
Al Si 7 Mg 0,3 (2)	Mini	6,50	0,20	0,10	0,10	0,25	0,05	0,10	0,05	0,05	0,08	0,03	0,10
	Maxi	7,50				0,40					0,25		
Al Si 7 Mg 0,6 (2)	Mini	6,50	0,20	0,10	0,10	0,45	0,05	0,10	0,05	0,05	0,08	0,03	0,10
	Maxi	7,50				0,70					0,25		
Al Si 10 Mg (2)	Mini	9,00	0,60	0,10	0,50	0,17	0,05	0,10	0,05	0,05	0,20	0,05	0,15
	Maxi	11,00				0,40							
Al Si 12 (2)	Mini	11,00	0,70	0,10	0,50	0,10	0,05	0,15	0,05	0,05	0,15	0,05	0,15
	Maxi	13,50											

(1) This alloy may contain less than 0,04% of beryllium, which is not to be considered as an impurity.
(2) These alloys may contain elements necessary to the eutectic modification with contents of less than 0,20%, which are not to be considered as impurities.
Note 1: Small variations in the contents of some elements in comparison to the values mentioned in this Table are possible in agreement with Tasneef

Table 8 : Aluminium alloy casting - Mechanical characteristics

Designation ISO (3)	Guaranteed minimum values			
	Minimum tensile strength R (N/mm ²)	Minimum yield stress R _{e 0,2} (N/mm ²) (1)	Elongation A (%) on 5,65 √S ₀	Brinell Hardness HB (2)
Al Mg 3-F	170	70	7,0	60
Al Mg 6-F	180	100	4,0	65
Al Si 2 Mg-F	170	70	5,0	50
Al Si 7 Mg-F	170	80	4,0	55
Al Si 7 Mg 0,3-T6	250	180	4,0	75
Al Si 7 Mg 0,6-T6	290	210	4,0	90
Al Si 10 Mg-F	170	90	4,0	55
Al Si 10 Mg-T6	250	180	1,5	80
Al Si 12-F	170	75	5,0	55

(1) For information only.
(2) Minimum hardness which can be specified for heat treated elements.
(3) F = as cast.
T6 = quenched and tempered.

Part D
Materials and Welding

Chapter 4

MISCELLANEOUS EQUIPMENT

SECTION 1 EQUIPMENT

SECTION 2 VARIOUS FINISHED PRODUCTS

SECTION 1 EQUIPMENT

1 Anchors and associated equipment

1.1

1.1.1 Anchors and associated components (heads, shanks and shackles) , studless chains, ropes and associated equipment are to be in compliance with the following standards:

EN 13573,
EN 15051,
EN 15271,
EN 15272,
EN 14310,
EN 14606,
EN14874.

SECTION 2

VARIOUS FINISHED PRODUCTS

1 Cast copper alloy propellers and propellers blades

1.1 Application

1.1.1 The requirements of this Article are applicable to the moulding, casting, inspection and repair procedures of new cast copper alloy propellers, blades and bosses.

1.1.2 These requirements may also be applied for the repair and inspection of propellers which become damaged during service.

1.2 Manufacture

1.2.1 All castings are to be manufactured at foundries approved by ^{Tasneef}

1.2.2 These castings are to be manufactured and tested in accordance with the appropriate requirements of Chapter 1 and Chapter 2 and the specific requirements of this Article.

1.3 Quality of castings

1.3.1 All castings are to be free from surface or internal defects liable to impair their use. Minor casting defects which may still be visible after machining, such as small cold shots and scabs, are to be trimmed off by the Manufacturer.

1.4 Condition of supply

1.4.1 At the option of the Manufacturer, castings may be supplied in the "as cast" or heat treated condition.

1.5 Chemical composition

1.5.1 Typical copper propeller alloys are grouped into the four types CU1, CU2, CU3, and CU4 depending on their chemical composition as given in Tab 1. Copper alloys whose chemical composition deviates from the typical values of Tab 1 are to be specially approved by ^{Tasneef}

1.5.2 The Manufacturer is to maintain records of the chemical analyses of the production casts, which are to be

made available to the Surveyor so that he can satisfy himself that the chemical composition of each casting is within the specified limits.

1.5.3 For copper-based alloys CU1 and CU2, in order to ensure adequate cold ductility and corrosion fatigue resistance, the proportion of beta phase is to be kept low. For this purpose, the zinc equivalent defined by the following formula is not to exceed a value of 45 %:

$$\text{Zinc equivalent (\%)} = 100 - (100 \cdot \%Cu / 100 + A)$$

in which A is the algebraic sum of the following values :

$$\begin{aligned} &1 \cdot \%Sn \\ &5 \cdot \%Al \\ &-0,5 \cdot \%Mn \\ &-0,1 \cdot \%Fe \\ &-2,3 \cdot \%Ni \end{aligned}$$

Note 1: The negative sign in front of the element Mn, Fe and Ni signifies that these elements tend to reduce the proportion of beta phase.

1.5.4 In addition to [1.5.3], the CU1 and CU2 type alloys are to contain an alpha phase component of at least 25%; this is to be checked on a test bar by the Manufacturer.

1.6 Mechanical properties

1.6.1 The requirements relevant to the mechanical properties are shown in Tab 2.

The values given in Tab 2 are applicable to test specimens taken from separately cast samples in accordance with Fig 1, or with any other recognised national standard.

It is to be noted that these properties are generally not representative of the mechanical properties of the propeller casting itself, which may be lower than that of a separately cast test coupon.

For integrally cast test specimens, the requirements are to be specially agreed with ^{Tasneef} wherever possible, the test samples are to be located on the blades in an area lying between 0,5 to 0,6 R, where R is the radius of the propeller. The test sample material is to be removed from the casting by non-thermal procedures.

Table 1 : Typical chemical composition of propeller and propeller blade castings

Alloy Type	CHEMICAL COMPOSITION (%)							
	Cu	Sn	Zn	Pb	Ni	Fe	Al	Mn
CU1	52 - 62	0,1 - 1,5	35 - 40	max. 0,5	max. 1,0	0,5 - 2,5	0,5 - 3,0	0,5 - 4,0
CU2	50 - 57	max. 0,15	33 - 38	max 0,5	3,0 - 8,0	0,5 - 2,5	0,5 - 2,0	1,0 - 4,0
CU3	77 - 82	max. 0,1	max. 1,0	max 0,03	3,0 - 6,0	2,0 - 6,0	7,0 - 11,0	0,5 - 4,0
CU4	70 - 80	max. 1,0	max. 6,0	max 0,05	1,5 - 3,0	2,0 - 5,0	6,5 - 9,0	8,0 - 20,0

Table 2 : Mechanical properties of cast copper alloys for propellers and propeller blade castings

Alloy type	Proof stress $R_{p0.2}$ (N/mm ²) min.	Tensile strength R_m (N/mm ²) min.	Elongation A5 (%) min.
CU1	175	440	20
CU2	175	440	20
CU3	245	590	16
CU4	275	630	18

Note 1:The values shown are related to specimens taken from separately cast samples as per Fig 1 or recognised national standards.

Note 2:The 0,2% proof stress values are to be determined for all keyless type propeller castings. For other types of propeller casting, these values are given for information purposes only and, unless expressly required, their determination may be omitted during testing.

The mechanical properties of alloys not meeting the limiting values of Tab 2 are to comply with the requirements of the relevant specification to be approved by Tasneef

1.7 Sampling and testing

1.7.1 Test samples are to be provided from each cast used for the manufacture of propeller blade casting.

1.7.2 The test samples are to be of keel block type, in accordance with the dimensions in Fig 1, and are to be cast in moulds made from the same type of materials as used for the castings.

1.7.3 Where castings are supplied in the heat treated condition, the test samples are to be heat treated together with the casting which they represent.

Figure 1 : Keel block test sample casting

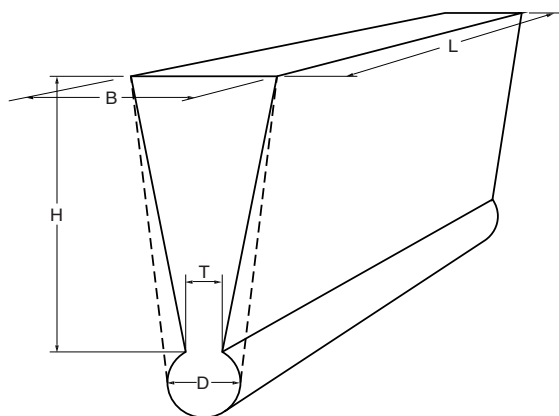

H=100mm ; B=50mm ; L>150mm ; T=15mm ; D=25mm

1.7.4 At least one tensile test specimen is to be taken from each ladle.

1.7.5 The results of all tensile tests are to comply with the requirements given in Tab 2.

1.7.6 Metallographic examination of alloy types CU1 and CU2 is to be verified by determining the proportion of alpha phase. For this purpose, at least one specimen is to be taken from each heat. The proportion of alpha phase is to be determined as the average value of 5 counts. The requirements of [1.5.4] are to be fulfilled.

1.8 Visual and dimensional examination

1.8.1 Propeller castings are to be visually inspected during the various stages of manufacture.

1.8.2 All finished castings are to be presented for examination by the Surveyor, and this is to include the bore and the examination of internal surfaces where applicable.

1.8.3 The dimensions, the dimensional and geometrical tolerances and their verification are the responsibility of the Manufacturer. The report on the relevant examinations is to be submitted to the Surveyor, who may require checks to be made in his presence.

1.8.4 Static balancing is to be carried out on all propellers. Dynamic balancing is required for propellers running above 500 rpm.

1.9 Inspection - Severity zones Non-destructive examinations

1.9.1 Propeller castings are to be cleaned and adequately prepared for inspection.

1.9.2 All finished propellers are to be presented for a comprehensive visual inspection by the Surveyor.

1.9.3 The skew of a propeller is defined as follows:

The maximum skew angle of a propeller blade is defined as the angle, in the projected view of the blade, between a line drawn through the blade tip and the shaft centreline and a second line through the shaft centreline which acts as a tangent to the locus of the mid-points of the helical blade section; see Fig 2.

High skew propellers have a skew angle greater than 25°, low skew propellers a skew angle of up to 25°.

1.9.4 For the purpose of the requirements of this Section, propellers and propeller blades are divided in order of importance into three zones, A, B and C, as shown in :

- Fig 3 for integrally cast low skew propeller
- Fig 4 for blades with skew angles greater than 25°
- Fig 5 for controllable pitch propeller boss
- Fig 6 for controllable pitch and built-up propeller.

Figure 2 : Definition of skew angle

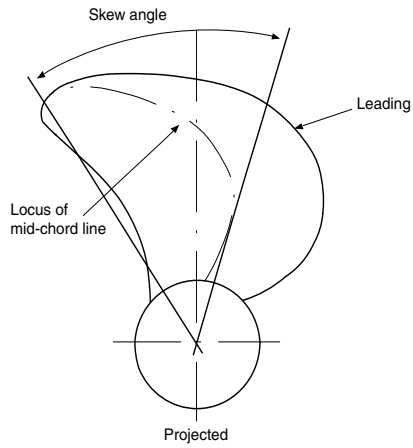

Figure 3 : Severity zones for integrally cast low skew propellers

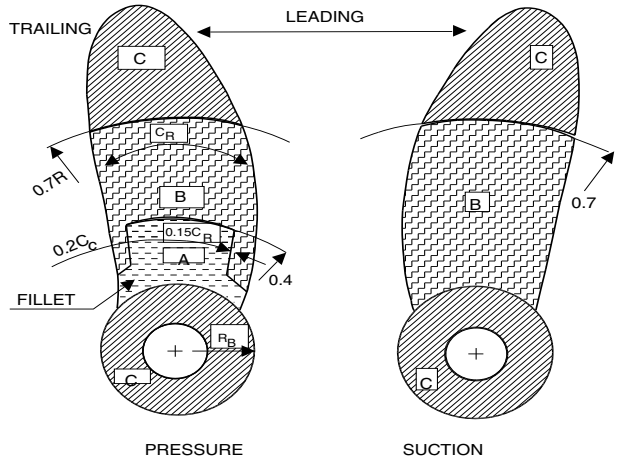

Figure 4 : Severity zones in blades with skew angles > 25°

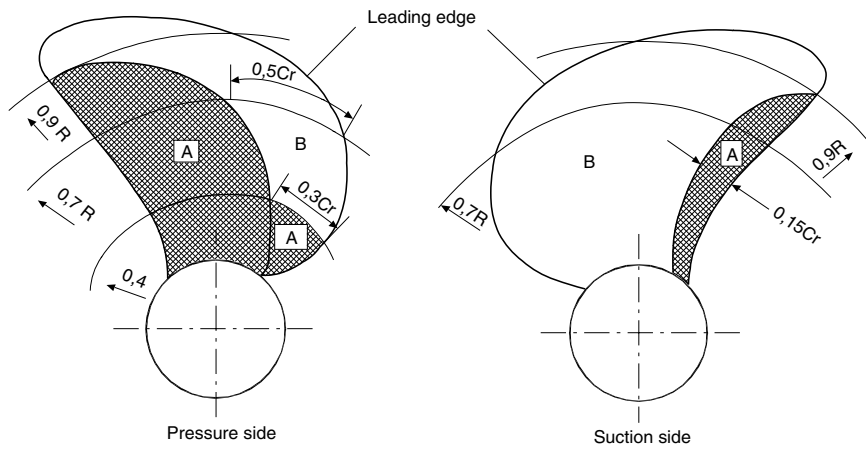
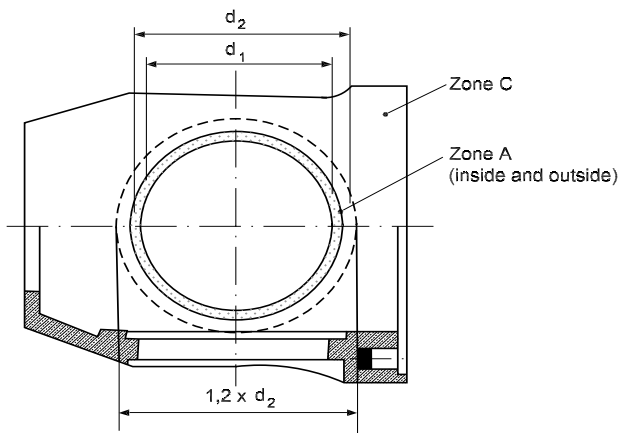
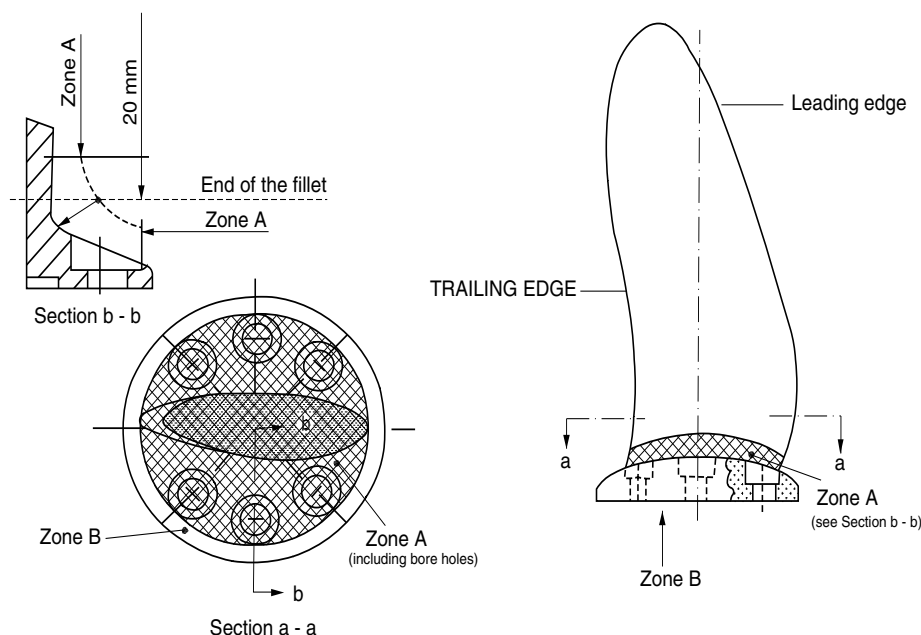

Figure 5 : Severity zones for controllable pitch propeller boss



**Figure 6 : Severity zones
for controllable pitch and built-up propeller**



1.10 Dye penetrant examination

1.10.1 Propeller castings are to be cleaned and adequately prepared. The dye penetrant examination is to be carried out in accordance with a recognised standard or an approved procedure.

1.10.2 The severity zones A as defined above are to be subjected to a dye penetrant examination in the presence of the Surveyor. In zones B and C the dye penetrant examination is to be performed by the Manufacturer and may be witnessed by the Surveyor upon his request.

If repairs have been made either by grinding or by welding, the repaired areas are additionally to be subjected to the dye penetrant examination irrespective of their location and/or severity zone.

1.10.3 In the dye penetrant examination an indication is the presence of detectable bleed-out of the penetrant liquid from the material discontinuities appearing at least 10 minutes after the developer has been applied.

A distinction is made between circular, linear and aligned indications; see Fig 7.

The reference area is defined as an area of 100 cm² which may be square or rectangular with the major dimension not exceeding 250 mm.

1.10.4 The surface is to be divided into reference areas of 100 cm² as given in [1.10.3]. The indications detected are, with respect to their size and number, not to exceed the values given in Tab 3. The area is to be taken in the most unfavourable location relative to the indication being evaluated.

1.10.5 In addition to the above acceptance criteria, small defects, such as pores less than 1 mm in diameter, may generally be disregarded except where they occur in closely spaced groups.

1.11 Radiographic and ultrasonic examination

1.11.1 When serious doubts arise suggesting that the casting is not free from internal defects, further non-destructive inspections, e.g. radiographic and/or ultrasonic tests, are to be carried out upon request of the Surveyor. The acceptance criteria are to be agreed between the Manufacturer and Tasneef in accordance with a recognised standard.

Figure 7 : Shape of indications

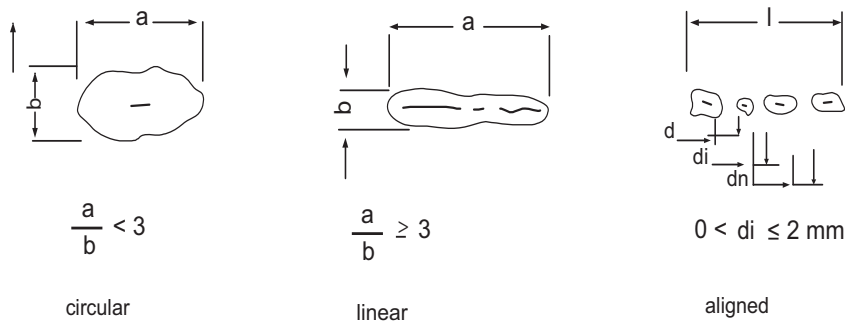

Table 3 : Allowable number and size of indications in a reference area of 100 cm² depending on severity zones

Severity zones	Max. total number of indications	Type of indication	Max. number of each type (1) (2)	Max. acceptable value for "a" or "l" of indications, in mm
A	7	Circular	5	4
		Linear	2	3
		Aligned	2	3
B	14	Circular	10	6
		Linear	4	6
		Aligned	4	6
C	20	Circular	14	8
		Linear	6	6
		Aligned	6	6

- (1) Singular circular indications less than 2 mm for zone A and less than 3 mm for the other zones may be disregarded.
 (2) The total number of circular indications may be increased to the maximum total number, or part thereof, represented by the absence of linear/aligned indications.

1.12 Repair procedures

1.12.1 Indications exceeding the acceptance standard of items [1.10.4] and [1.10.5], cracks, shrinkage cavities, sand, slag and other non-metallic inclusions, blow holes and other discontinuities which may impair the safe service of the propeller are defined as defects and are to be repaired.

1.12.2 In general the repairs are to be carried out by mechanical means, e.g. by grinding, chipping or milling. Welding may be applied, subject to the agreement of Tasneef if the relevant requirements detailed hereafter are satisfied.

1.12.3 After milling or chipping, grinding is to be applied for such defects which are not to be welded. Grinding is to be carried out in such a manner that the contour of the ground depression is as smooth as possible. Complete elimination of the defective material is to be verified by dye penetrant examination.

1.12.4 Localised pores on the end face or bore of a propeller boss, which themselves do not affect the strength of the casting, can be filled with a suitable plastic filler after the appropriate preparation of the defective area. The foundry is

to keep records and details of all castings which have been rectified.

1.12.5 In zone A, repair welding will generally not be allowed unless specially approved by Tasneef

Grinding can be carried out to an extent which maintains the blade thickness of the approved drawings.

The possible repair of defects which are deeper than those referred to above will be specially considered by Tasneef

1.12.6 In zone B, defects that are not deeper than $d_B = (t/40)$, in mm (where t is the minimum local thickness in mm according to the Rules) or 2 mm, whichever is the greater, are to be removed by grinding. Those defects that are deeper than allowable for removal by grinding may be repaired by welding.

1.12.7 In zone C, repair welds are generally permitted.

1.12.8 All weld repairs are to be documented by means of sketches or photographs showing the location and major dimensions of the grooves prepared for welding. Weld repairs are to be undertaken only when they are considered to be necessary and with the prior agreement of the Sur-

veyor. Welding of areas less than 5 cm² and depths of less than 2 mm is to be avoided.

1.12.9 Before welding is started, the company concerned is to prepare and submit to ^{Tasneef} a detailed welding procedure specification covering the weld preparation, welding position, welding parameter, welding consumables, pre-heating and post-weld heat treatment and inspection procedures.

1.12.10 Areas which are prepared for welding are to be subjected to dye penetrant examination and, irrespective of their location, they are always to be assessed in accordance with criteria for zone A.

1.12.11 Welding is preferably to be carried out in the downhand (flat) position. Adequate preheating is to be carried out with care to avoid local overheating.

1.12.12 All weld repairs are to be made by qualified welders following qualified procedures.

1.12.13 The area of any single repair and the maximum total area in any zone or region are generally to be kept within the following limits, where *S*, in cm², is the blade area surface or, for zones outside the blades, the area of the relevant zone (here after "other zones"):

- Zone A: no repairs
- Zone B and C, single: 0,006*S* or 60cm², whichever is the greater
- Zone B (leading edge), total: 0,008*S* or 100cm², whichever is the greater
- Zone B+C, total: 0,02*S* or 200cm², whichever is the greater
- Other zone, single area: 0,015*S* or 20cm², whichever is the greater
- Other zones, total for each zone: 0,05*S* or 50cm², whichever is the greater. Other zones means in particular the following surfaces:
 - a) for integrally cast propellers:
 - within the bore
 - outer surfaces of the boss to the start of the fillet radius
 - forward and aft end faces of the boss
 - b) for separately cast propeller blades:
 - surfaces of the flange to the start of the fillet radius.

Where repairs exceeding the above limits are proposed, their type, procedure and extent are to be individually examined by ^{Tasneef} before commencement of the repair, and any conditions will be specified.

1.12.14 All welding work is to be carried out in a shop free from draughts and adverse weather.

1.12.15 Metal arc welding with electrodes or filler wire used in the qualification procedure tests is to be employed. The welding consumables are to be stored and handled in accordance with the Manufacturer's recommendations. The grooves prepared for welding are to be ground smooth and complete elimination of the defective material is to be veri-

fied by dye penetrant examination. Slag, undercuts and other imperfections are to be removed before depositing the next run.

1.12.16 With the exception of alloy type Cu 3 castings, all weld repairs are to be stress relief heat treated. However, stress relief heat treatment of alloy type Cu 3 castings is required after major repairs in zone B (and zone A when specially approved) or if a welding consumable depositing a metal susceptible to stress corrosion cracking is used (e.g. with chemical composition of alloy type Cu 4).

1.12.17 Stress relief heat treatment is to be within the following temperature range:

- Cu 1: 350°C - 500°C
- Cu 2: 350°C - 550°C
- Cu 3: 450°C - 500°C
- Cu 4: 450°C - 600°C

Soaking times are to be in accordance with Tab 4. The heating and cooling are to be suitably controlled to minimise residual stresses. The cooling rate after any stress relieving heat treatment is not to exceed 50°C/h until a temperature of 200°C is reached.

1.12.18 When welding operations, including stress relief heat treatment, are completed, welded areas in finished machined and/or grinded condition are to be subjected to visual inspection and dye penetrant examination and assessed in accordance with criteria for zone A.

1.12.19 The foundry is to keep full records detailing the welding procedure, heat treatment and extent and location of repairs made on each casting. These records are to be available for review by the Surveyor and copies are to be handed over to the Surveyor upon his request.

1.13 Straightening

1.13.1 For hot and cold straightening purposes, static loading only is to be used.

1.13.2 Hot straightening of a bent propeller blade or a pitch modification is to be carried out after heating the bent region and approximately 500 mm wide zone on either side of it to the following suggested temperature range:

- alloy grade Cu 1: 500°C - 800°C
- alloy grade Cu 2: 500°C - 800°C
- alloy grade Cu 3: 700°C - 900°C
- alloy grade Cu 4: 700°C - 850°C.

The heating is to be slow and uniform and concentrated flames, such as oxyacetylene and oxy-propane, are not to be used. Sufficient time is to be allowed for the temperature to become fairly uniform through the full thickness of the blade section. The temperature is to be maintained within the suggested range throughout the straightening operation. A thermocouple instrument or temperature indicating crayons is/are to be used for measuring the temperature.

1.13.3 Cold straightening is to be used for minor repairs of tips and edges only. Cold straightening on castings made of

alloy type Cu 1, Cu 2 and Cu 4 are always to be followed by a stress relief heat treatment; see Tab 4.

1.14 Identification and marking

1.14.1 The Manufacturer is to adopt a system of identification which will enable all castings to be traced back to their heats.

1.14.2 In addition to the indications required in Ch 1, Sec 1, [4.1.1], all castings which have been tested and inspected with satisfactory results are to be marked with the following details:

- Manufacturer's mark
- grade of cast material
- heat number, casting number or another mark enabling the manufacturing process to be traced back
- number of Tasneef certificate
- skew angle if in excess of 25°; see [1.9.3].

1.14.3 The Manufacturer is to supply the Surveyor with a certificate containing the following details:

- purchaser and order number
- shipbuilding project number, if known
- description of casting with drawing number
- diameter, number of blades, pitch, direction of turning
- grade of alloy and chemical composition of each heat
- heat or casting number
- final weight
- results of non-destructive tests and details of test procedure, where applicable

- portion of alpha-structure for CU1 and CU2 alloys
- results of the mechanical tests
- casting identification number
- skew angle for high skew propellers; see [1.9.3].

2 Pressure bottles

2.1 Application

2.1.1 General

The requirements of this Article apply to seamless pressure bottles in carbon, carbon manganese and alloy steels, and to welded bottles in carbon and carbon manganese steels.

Seamless bottles are mainly used for carbon dioxide systems and welded bottles for portable fire extinguishers.

Steel grades to be used for the manufacture are to comply with those specified in Chapter 2 as applicable or with recognised standards.

The steel is to be killed and for certain applications, for example low temperature applications, fine grained steel is to be used.

2.1.2 Mass production

In the case of small bottles mass produced by Manufactures who have been approved by Tasneef for this purpose, alternative testing procedures to those indicated in [2.3.1] may be accepted.

2.1.3 Materials other than steel

The requirements relevant to bottles in material other than steel are to be considered on a case-by-case basis, with criteria and procedures as similar as possible to those specified in this Article.

Table 4 : Soaking times for stress relief heat treatment of copper alloy propellers

Stress relief temperature (°C)	Alloy Grade Cu 1 and Cu 2		Alloy Grade Cu 3 and Cu 4	
	Hours per 25 mm of thickness	Maximum recommended total hours	Hours per 25 mm of thickness	Maximum recommended total hours
350	5	15	-	-
400	1	5	-	-
450	1/2	2	5	15
500	1/4	1	1	5
550	1/4	1/2	1/2 (1)	2 (1)
600	-	-	1/4 (1)	1 (1)

(1) 550°C and 600°C applicable to Cu 4 alloys only.

2.2 Manufacture

2.2.1 Bottles are to be manufactured according to approved plans.

The manufacturing process of seamless bottles is to be approved for the individual Manufacturers.

The approval of the manufacturing process is also required for welded bottles intended for portable fire extinguishers having thickness of the cylindrical shell less than 3 mm.

Provisions for approval are given in the document, "Guide for Approval of Manufacturers".

The materials used in the bottle manufacture are to be tested or provided with a Manufacturer's certificate of conformity.

2.3 Inspection and tests

2.3.1 General

The following inspections and tests are to be performed:

- a) sectioning of one bottle from each batch formed of 200 pieces or fraction thereof, homogeneous as regards dimensions, manufacturing process and heat treatment for the execution of :
 - thickness measurements of the shell on three transverse sections in way of neck, middle and bottom end
 - 1 tensile test on longitudinal test specimen, 2 bending tests to be performed along the curvature and, for thicknesses ≥ 5 mm, 3 Charpy V-notch impact tests on longitudinal specimens, to be performed at -20°C . For low temperature applications, the test temperature is to be specified in the individual cases.
- b) hardness tests to be performed on bottles of quenched and tempered steel and, at the discretion of the Surveyor, also in other cases
- c) external and internal visual examination (direct examination or, in the case of insufficient size of openings, examination by auxiliary means), dimensional check, determination of tare and capacity (such examinations are to be performed by the Manufacturer with checks at the Surveyor's discretion)
- d) hydrostatic test on each bottle; test pressure as required by the relevant Rules or by the particular requirements applicable in the individual cases
- e) non-destructive checks as indicated on the plans at the time of the approval of the manufacturing process
- f) for welded bottles, additional tests on welded joints as specified at the time of the approval of the manufacturing process or indicated on the approved plans.

2.3.2 Tensile test

In the tensile test, the values of the yield strength R_{eH} and $R_{p0,2}$, the tensile strength R_m and the elongation A (%) are to

comply with the values specified for the corresponding steel.

The value of A (%) min, for thicknesses equal to or greater than 3 mm, is to be not less than the value calculated with the following formula, and in no case less than 14% :

$$A \geq \frac{2500}{0,224 \cdot R_m}$$

where R_m is the value, in N/mm^2 , of the tensile strength determined by the tensile test.

This requirement for A (%) min may be reduced by 15% for thicknesses less than 3 mm down to 2 mm, and by 30% for thicknesses less than 2 mm.

2.3.3 Bend test

In the bending test, the angle to which the specimen is to be bent without showing defects is 180° ; a mandrel having a diameter not exceeding "n" times the thickness of the specimen, depending on the minimum specified tensile strength R_m for the steel, as specified in Tab 5, is to be used.

Table 5 : Coef. n for determination of the max. allowed mandrel diameter in bend test

R_m (N/mm^2)	n
≤ 430	2
431 - 510	3
511 - 590	4
591 - 690	5
691 - 790	6
791 - 890	7
> 890	8

2.3.4 Impact test

In the Charpy V-notch impact test, the value of the absorbed energy, determined as an average of three tests, is to be not less than the value indicated in Tab 6 depending on the minimum tensile strength of the steel.

Table 6 : Impact test - requirements

Steel types	Tensile strength (N/mm^2)	Average impact energy at -20°C min. KV (J/cm^2)
Carbon and carbon- manganese	≤ 510	34
Alloy steels quenched and tempered	> 510	49

2.4 Identification, marking and certification

2.4.1 The Manufacturer is to adopt a system of identification which will enable all finished bottles to be traced to the original materials and their manufacturing.

All bottles which have been tested and inspected with satisfactory results are to be marked with the following details:

- a) Manufacturer's name or trade mark
- b) Society's brand
- c) place and date of testing
- d) production number or other marking enabling the traceability
- e) test pressure
- f) additional optional marks such as file number and code of the local inspection office, Surveyor's personal stamp.

Special marking and certification procedures may be agreed upon for supplies by Manufacturers granted the use of an alternative testing procedure.

2.4.2 The testing documentation indicated in Ch 1, Sec 1, [4.2.1] is required and is to include all the information, as appropriate.

The testing or works' certificate of the material used is to be enclosed with the testing documentation.

Where applicable, the reports relevant to the non-destructive examination, pressure test and heat treatment are to be enclosed with the testing documentation.

2.4.3 Before signing Tasneef inspection certificate, the Surveyor is to be provided by the Manufacturer with a written declaration stating that the bottles have been manufactured by a process approved by Tasneef they comply with the applicable requirements and they have been satisfactorily tested in accordance with Tasneef Rules.

3 Cast steel propellers and propeller blades

3.1 Application

3.1.1 The requirements of this Article are applicable to the moulding, casting, inspection and repair procedure of cast steel propellers, blades and bosses.

3.1.2 Where the use of alternative alloys is proposed, particulars of chemical composition, mechanical properties and heat treatment are to be submitted for approval.

3.1.3 These requirements may also be used for the repair and inspection of propellers which become damaged during service, subject to prior agreement with Tasneef

3.2 Manufacture

3.2.1 All propellers, blades and bosses are to be manufactured at foundries approved by Tasneef The scope of the procedure tests involved in the approval is to be agreed.

3.2.2 These castings are to be manufactured and tested in accordance with the appropriate requirements of Chapter 1 and Chapter 2 and the specific requirements of this Article.

3.3 Quality of castings

3.3.1 All castings are to be free from surface and internal defects liable to impair their in-service performance.

3.4 Condition of supply

3.4.1 Martensitic castings are to be supplied in the austenitized and tempered condition. Austenitic castings are to be solution treated.

3.5 Chemical composition

3.5.1 Typical cast steel propeller alloys are grouped into four types depending on their chemical composition as given in Tab 7.

Table 7 : Typical chemical composition of steel propeller castings

Alloy type	C Max. (%)	Mn Max. (%)	Cr (%)	Mo (1) Max. (%)	Ni (%)
Martensitic (12Cr 1Ni)	0,15	2,0	11,5-17,0	0,5	Max. 2,0
Martensitic (13Cr 4Ni)	0,06	2,0	11,5-17,0	1,0	3,5-5,0
Martensitic (16Cr 5Ni)	0,06	2,0	15,0-17,5	1,5	3,5-6,0
Austenitic (19Cr 11Ni)	0,12	1,6	16,0-21,0	4,0	8,0-13,0
(1) Minimum values are to be in accordance with recognised national or international standards					

3.6 Mechanical properties

3.6.1 The requirements relevant to the mechanical properties are shown in Tab 8. These values refer to the test specimens machined from integrally cast test bars attached to the hub or on the blade.

Where possible, the test bars attached on the blades are to be located in an area lying between 0,5 to 0,6R, where R is the radius of the propeller.

The test bars are not to be detached from the castings until the final heat treatment has been carried out. Removal is to be by non-thermal procedures.

Table 8 : Mechanical Properties for steel propeller castings

Alloy type	Proof stress $R_{p0.2}$ min. (N/mm ²)	Tensile strength R_m min. (N/mm ²)	Elongation A_5 min. (%)	Red. of area Z min. (%)	Charpy V-notch (1) Energy min. (J)
12Cr 1Ni	440	590	15	30	20
13Cr 4Ni	550	750	15	35	30
16Cr 5Ni	540	760	15	35	30
19Cr 11Ni	180 (2)	440	30	40	-
(1) Tests to be made at -10°C for Ice Class Notations IAS, IA and IB only					
(2) $R_{p1.0}$ value is 205 N/mm ²					

3.6.2 Separately cast test bars may be used subject to the prior approval of ^{Tasneef} The test bars are to be cast from the same heat as the castings represented and heat treated with the castings which they represent.

3.7 Sampling

3.7.1 At least one set of mechanical tests according to Ch 1, Sec 2, [2.1.3] is to be made on material representing each casting.

3.7.2 As an alternative to [3.7.1], where a number of small propellers of about the same size, and less than 1m in diameter, are made from one cast and heat treated in the same furnace charge, a batch testing procedure may be adopted using separately cast test samples of suitable dimensions. At least one set of mechanical tests is to be provided for each multiple of five castings in the batch.

3.8 Visual and dimensional examination

3.8.1 All finished castings are to be 100% visually inspected by the Surveyor. The Surveyor may require areas to be etched for the purpose of investigating weld repairs.

3.8.2 The castings are to be free from cracks, hot tears or other imperfections which, due to their nature, degree or extent, will interfere with the use of the castings.

3.8.3 The dimensions, the dimensional and geometrical tolerances and their verification are the responsibility of the Manufacturer. The report on the relevant examinations is to be submitted to the Surveyor, who may require checks to be made in his presence.

3.8.4 Static balancing is to be carried out on all propellers in accordance with the approved drawings. Dynamic balancing may be necessary for propellers running above 500 rpm.

3.9 Non-destructive examinations - Severity Zones

3.9.1 All finished castings are to be submitted to non-destructive testing in accordance with the requirements given in [3.9.2] to [3.9.9].

3.9.2 In order to relate the degree of non-destructive testing to the criticality of imperfections, propeller blades are divided into three Severity Zones designated A, B and

C. In addition, a distinction is made between low skew and high skew propellers. See [1.9].

3.9.3 For all propellers, separately cast blades and hub, the surface covered by severity Zones A, B and C are to be dye penetrant tested. Testing of Zone A is to be undertaken in the presence of the Surveyor. In Zones B and C the dye penetrant inspection is to be performed by the Manufacturer and may be witnessed by the Surveyor at his request.

3.9.4 If repairs have been made by grinding or by welding, the repaired areas are additionally to be subjected to dye penetrant testing irrespective of their location and/or severity zone. Weld repairs are, irrespective of their location, always to be assessed according to Zone A.

3.9.5 Where serious doubts arise that the casting is not free from internal defects, further non-destructive inspections, e.g. radiographic and/or ultrasonic tests, are to be carried out. The acceptance criteria are to be agreed between the Manufacturer and ^{Tasneef}

3.9.6 In the dye penetrant inspection an indication is the presence of detectable bleed-out of the penetrant liquid from the material discontinuities appearing at least 10 minutes after the developer has been applied. The following definitions apply:

- Linear indication: an indication in which the length is at least three times the width;
- Nonlinear indication: an indication of circular or elliptical shape with a length less than three times the width;
- Aligned indications: three or more indications in a line, separated by 2 mm or less edge-to-edge;
- Open indication: an indication that can be detected by use of contrast dye penetrant;
- Non-open indication: an indication that cannot be detected by the use of contrast dye penetrant;
- Relevant indication: an indication that is caused by a condition or type of discontinuity that requires an evaluation. Only indications which have any dimension greater than 1.5mm are to be considered relevant.

3.9.7 For the purpose of evaluating indications, the surface is to be divided into reference areas of 100 cm², which may be square or rectangular with the major dimension not exceeding 250 mm. The area is to be taken in the most unfavorable location relative to the indication being evaluated.

3.9.8 With respect to their size and number, the indications detected are not to exceed the values given in Tab 9.

3.9.9 The foundry is to keep records of inspections traceable to each casting. These records are to be reviewed by the Surveyor. The foundry is also to provide the Surveyor with a statement confirming that non-destructive tests have been carried out with satisfactory results.

3.10 Repair procedures

3.10.1 Defective castings are to be repaired in accordance with the requirements given in [3.10.2] to [3.10.7] and, where applicable, the requirements given in [3.10.8] to [3.10.14].

3.10.2 In general the repairs are to be carried out by mechanical means, e.g. by grinding or milling. The resulting grooves are to be blended into the surrounding surface so as to avoid any sharp contours. The local surface is to be

subsequently subjected to dye penetrant examination to ensure that the defects have been completely eliminated.

3.10.3 Weld repairs are to be carried out only where deemed necessary and accepted by the Surveyor. All weld repairs are to be documented by means of sketches or photographs showing the location and major dimensions of the grooves prepared for welding. The documentation is to be presented to the Surveyor prior to repair welding.

3.10.4 The weld grooves are to be suitably shaped to allow good access for welding and ground smooth, and complete elimination of the defective material is to be verified by liquid penetrant testing. Welds having an area less than 5 cm² are to be avoided.

3.10.5 Repair by grinding in Severity Zone A is allowed to an extent to maintain the required thickness of the blade.

In Zone A, repairs by welding are in general not permitted unless specially considered by Tasneef

Therefore where such a repair is proposed, the extent and procedure are to be submitted in detail for acceptance.

3.10.6 Defects in severity Zone B that are not deeper than $t/40$ ("t" is the minimum local thickness according to the Rules) or 2 mm, whichever is the greater, are to be removed by grinding. Defects that are deeper may be repaired by welding subject to the prior approval of Tasneef

3.10.7 Repair by welding is generally permitted in Severity Zone C.

3.10.8 Before welding is started, a detailed welding procedure specification is to be submitted covering the weld preparation, welding positions, welding parameters, welding consumables, preheating, post-weld heat treatment and inspection procedures.

3.10.9 All weld repairs are to be made by qualified welders using qualified procedures. The requirements for welding procedure qualification tests are given in Ch 5, Sec 4.

Table 9 : Allowable number and size of indications depending on severity zones

Severity zone	Max. total number of indications	Indication type	Max. number for each type (1) (2)	Max. dimension of indication (mm)
A	7	Non - linear	5	4
		Linear	2	3
		Aligned	2	3
B	14	Non - linear	10	6
		Linear	4	6
		Aligned	4	6
C	20	Non - linear	14	8
		Linear	6	6
		Aligned	6	6

(1) Single non-linear indications less than 2mm in Zone A and less than 3mm in other zones may be disregarded.
 (2) The total number of non-linear indications may be increased to the maximum total number, or part thereof, represented by the absence of linear or aligned indications.

3.10.10 The metal welding electrode or filler wire used in the procedure tests is to be used. The welding consumables are to be stored and handled in accordance with the Manufacturer's recommendations.

3.10.11 All welding work is to be carried out in a shop free from draughts and influence of the weather.

3.10.12 The martensitic steels are to be furnace re-tempered after weld repair. Subject to prior approval, however, local stress relieving may be considered for minor repairs.

3.10.13 On completion of heat treatment the weld and the adjacent material are to be ground smooth. All weld repairs are to be submitted to liquid penetrant examination.

3.10.14 The foundry is to keep full records detailing the weld procedure, heat treatment, inspection and extent and

location of repairs made to each casting. These records are to be reviewed by the Surveyor.

3.11 Identification

3.11.1 The Manufacturer is to adopt a system of identification which will be able to suitably identify, prior to the final inspection by the Surveyor, each individual casting as follows:

- a) Manufacturer's mark
- b) grade of cast material
- c) heat number, casting number or another mark enabling the full history of the casting to be traced back
- d) number of Tasneef certificate
- e) ice class symbol where applicable
- f) skew angle for high skew propellers.

3.11.2 When the casting has been accepted ^{Tasneef} stamp is to be put on with the date of the final inspection of the casting.

3.12 Certification

3.12.1 The Manufacturer is to supply the Surveyor with an inspection certificate containing the following details:

- a) Purchaser and heat number
- b) shipbuilding or ship identification, if known
- c) description of the casting with drawing number
- d) diameter, number of blades, pitch, direction of turning
- e) type of alloy, heat or casting number and chemical composition
- f) final mass
- g) skew angle for high skew propellers
- h) details of time and temperature of heat treatment
- i) results of mechanical tests.

3.12.2 The Manufacturer is to provide a statement of the results of non-destructive tests and details of test procedures and, where applicable, records of weld repairs as required by [3.10.14].

Part D
Materials and Welding

Chapter 5
WELDING

- SECTION 1 GENERAL REQUIREMENTS**
- SECTION 2 APPROVAL OF WELDING CONSUMABLES**
- SECTION 3 APPROVAL OF OVER WELDABLE SHOP PRIMERS**
- SECTION 4 APPROVAL OF WELDING PROCEDURES**
- SECTION 5 APPROVAL OF CO₂ LASER WELDING PROCEDURES**

SECTION 1

GENERAL REQUIREMENTS

1 Application

1.1 General

1.1.1 This Section specifies the general requirements for fabrication by welding, and the other Sections of the Chapter concern the requirements for approval of welding consumables (Sec 2), over weldable shop primers (Sec 3) and welding procedures (Sec 4 and Sec 5).

1.1.2 The requirements are essentially intended for the welding of weldable steels and aluminium alloy grades covered by the applicable Articles of this Part D.

1.1.3 Different materials, applications and procedures, as well as other standards and specifications, may be considered by ^{Tasneef} on a case-by-case basis.

2 Fabrication by welding

2.1 General

2.1.1 Fabrication by welding is to be carried out in compliance with the applicable Society Rules and according to normal good practice, general or specific to the individual processes, to the Surveyor's satisfaction; in particular the conditions stated at the time of approval and authorisation for the use of individual processes are to be complied with.

The welded structures, the relevant details and the size of welds are to comply with the applicable requirements; any other requirements indicated on the approved plans or specified during survey of construction are also to be complied with.

2.2 Approval

2.2.1 Plans

The constructional plans are to be submitted for approval when required by the Rules or in individual cases and are to contain the necessary data relevant to the fabrication by welding of the structures and items represented. In particular, material types, welding details, welding processes and weld size are to be indicated; any details not represented in the plans are, in any case, to comply with the applicable requirements.

2.2.2 Welding procedures and consumables

Welding to be used in hull construction, machinery, pressure systems and equipment subject to the inspection of ^{Tasneef} is to be carried out with approved welding consumables and in accordance with approved welding procedures.

2.2.3 Welders

Welders for manual welding and for semiautomatic welding processes are to be properly trained and are to be certified by ^{Tasneef} as required in the individual applications.

Welders are certified according to standards recognised by ^{Tasneef} EN 287 and ISO 9606 are standards recognised by ^{Tasneef} the acceptance of other standards is subject to preliminary examination by ^{Tasneef}

The certification is to be in due course of validity.

The recognition of certificates issued by other certification bodies will be evaluated on a case by case basis and verification of welders qualification will be required as deemed necessary.

2.2.4 Welding operators

Personnel manning fully automatic welding machines are to be competent and sufficiently trained.

Record of training is to be maintained and submitted to ^{Tasneef} on demand.

2.2.5 Welding supervision

Welders are to be supervised and assisted, in the course of the welding operation, by an adequate number of competent supervisors, such as to ensure efficient control of the welding production.

In the Rules for the certification of welding inspectors, the duties of the personnel who perform specific inspection activities on the production by welding are listed in detail, according to levels of competence.

Certification of the welding inspectors is not compulsory and is left to the discretion of the Manufacturer, except in particular cases where it may be required by ^{Tasneef}

2.2.6 NDT operators

Non-destructive tests are to be carried out by personnel, qualified according to the requirements of Ch 1, Sec 1, [3.6.4].

The qualifications are to be appropriate to the particular application.

2.3 Welding procedures

2.3.1 Approval of consumables

Consumables are to be approved in accordance with the provisions of Sec 2.

Requirements for approval of welding processes, where non-approved welding consumables are allowed to be used, are given in Sec 4.

2.3.2 Choice of consumables

Requirements regarding the use of the various grades of approved consumables are indicated in the parts of the

Rules concerning the application or at the time of plan approval.

In particular, for consumables intended for welding hull and structural C and C-Mn steels, the requirements given in Pt B, Ch 12, Sec 1 apply.

In the case of consumables approved for Mo and Cr-Mo weldable steels, the choice of the grade of the consumables is to be made such that the nominal chemical composition of the deposited metal corresponds to that of the base material; where electrodes are used, they are to be of the basic covered low hydrogen type.

In the case of consumables approved for C, C-Mn and Ni ferritic steels intended for low temperature service, the choice of the grade of consumable is to be made such that the strength of the weld metal is appropriate to the base metal to be welded and the temperature at which the consumables satisfy the required impact strength properties is as required in the individual applications; where electrodes are used, they are to be of the basic covered low hydrogen type.

In the case of consumables approved for welding stainless steels, the selection of consumables and base metals which can be welded is indicated in Sec 4, [3].

In the case of consumables approved for welding aluminium alloys, the selection is to be made on the basis of corrosion resistance and strength as indicated in Sec 4, [6].

2.3.3 Approval of welding procedures

Welding procedures are to be approved in accordance with the provisions of Sec 4.

For specific applications relevant to ships intended to carry liquefied gases, the relevant requirements of Pt E, Ch 1, Sec 14 apply.

2.4 Type of joints, edge preparations and size

2.4.1 General

The types of joints and the edge preparations are to be appropriate to the welding processes adopted, to the particular structures and to the stresses to which they are subjected, to the satisfaction of ^{Tasneef}

Size and design are to be in accordance with requirements given in the Rules relevant to the applications, approved plans, and specific provisions stipulated for hulls in Part B and for pressure systems and machinery in Part C.

2.5 Welding execution and control

2.5.1 Edge preparation, surface conditions, assembly pre- and post-weld heating, welding sequences and inspections of the welded structures are to be in accordance with good practice and, where applicable, are to comply with the requirements given in the Rules relevant to the applications (Part B for hulls and Part C for pressure systems and machinery).

SECTION 2

APPROVAL OF WELDING CONSUMABLES

1 General

1.1 Application

1.1.1 The requirements of this Section apply to the approval and periodical control tests of consumables for welding carbon and carbon manganese steels, high strength quenched and tempered steels, chromium and chromium-molybdenum steels, nickel steels for low temperature applications, austenitic and austenitic-ferritic stainless steels, and aluminium alloys.

This Article specifies the requirements common to all the above-mentioned welding consumables, while the appropriate specific requirements are indicated in Articles [2] to [14].

The following categories of welding consumables are considered:

- covered electrodes for manual and gravity welding
- wire/flux combinations for submerged arc welding
- solid wire/gas combinations for continuous wire arc welding
- flux cored wires for continuous wire arc welding with or without shielding gas
- consumables for electrogas and electroslag welding.

1.2 Grading and designation

1.2.1 General

Consumables are classified depending on the mechanical and chemical properties of the filler metal; different grades or type of consumables may be considered for specific applications or materials on a case-by-case basis.

1.2.2 Consumables for C and C-Mn steels and for Q-T steels

Welding consumables intended for welding C and C-Mn steels are divided into groups related to the strength level (minimum specified yield strength) of the steel; each group is subdivided into grades depending on the impact test temperatures, as indicated in Tab 1.

1.2.3 Consumables for Mo and Cr- Mo steels

Consumables intended for welding Mo and Cr-Mo steels are designated by a symbol indicating the nominal Mo and Cr percentage content of the deposited weld metal, as follows:

- M for Mo = 0,5
- C1M for Cr = 1,25 and Mo = 0,5
- C2M1 for Cr = 2,25 and Mo = 1

1.2.4 Consumables for Ni steels for low temperature applications

Consumables intended for welding nickel steels are designated by a symbol indicating the type of nickel steel for which the consumables are intended, as follows:

- N15 for steels with Ni = 1,30 - 1,70 (%)
- N35 for steels with Ni = 3,25 - 3,75 (%)
- N50 for steels with Ni = 4,75 - 5,25 (%)
- N90 for steels with Ni = 8,50 - 10 (%)

1.2.5 Consumables for austenitic and austenitic-ferritic (duplex) stainless steels

Consumables intended for welding austenitic steels are designated by a symbol corresponding to the AWS designation of the weld deposit, as follows: 308, 308L, 316, 316L, 316LN, 317, 317L, 309L, 309, 309Mo, 310, 310Mo, 347.

Consumables intended for welding austenitic-ferritic steels are designated by a symbol indicating the nominal percentage content of Cr and Ni in the deposited metal (e.g. 2205 means 22% Cr and 5% Ni).

Table 1 : Consumable grades for C-Mn steels

Steel strength level	Consumable grades based on impact test temperature at (°C)				
	+ 20	0	-20	-40	-60
Normal strength	1	2	3	4	-
Higher strength steels (1) - ≥ 315 , < 360 N/mm ² - ≥ 360 , < 400 N/mm ²	1Y (2)	2Y 2Y40	3Y 3Y40	4Y 4Y40	5Y 5Y40
High strength quenched and tempered steels (1)			3Y42-46-50-55-62-69	4Y42-46-50-55-62-69	5Y42-46-50-55-62-69
(1) The symbol Y, which indicates the high strength steel groups is followed, for steels having the minimum specified yield strength equal to or higher than 355N/mm ² , by a number related to the minimum specified yield strength value of the weld metal (e.g. 42 for a minimum yield strength of 420 N/mm ²).					
(2) Grade not applicable to covered electrodes.					

1.2.6 Consumables for aluminium alloys

Consumables intended for welding aluminium alloys are designated by the initial letter W or R for wire or rod products, respectively, and by the letters A, B, C, D depending on the alloy type and strength level used for the approval tests.

1.2.7 Additional symbols

Further symbols may be added, as appropriate, to the grading details, as follows:

- a) H or H15, HH or H10, H5 for controlled hydrogen content of weld metal as per Tab 8
- b) T, M, U or TM for automatic process with two run (T), multi-run (M), one side (U) or both (TM) welding techniques
- c) S for semiautomatic welding process
- d) D when mechanical properties on weld metal have also been verified in the stress relieved condition
- e) A or B when hot cracking tests have been performed on steels of specific composition.

1.3 Approval procedure

1.3.1 Request for approval

The request for approval is to be submitted to Tasneef by the Manufacturer, together with the specific information indicated in the Articles relevant to the various consumables.

1.3.2 Quality of manufacturing

The Manufacturer's plant, method of production and quality control of welding consumables are to be such as to ensure reasonable uniformity in manufacture.

The Manufacturer is to ascertain this uniformity by means of analysis and systematic testing on each production batch.

In general, the consumables are to maintain the specified characteristics for a period of time of at least six months after the date of delivery, when properly stored in a dry atmosphere and kept in the original packaging.

The consumables are to be supplied so packaged as to ensure compliance with the above requirement; the packaging is to be sufficiently strong to resist the usual transportation and handling operations.

The Manufacturer is to stamp on each container or bag, as applicable, the markings which are necessary to trace back each production.

1.3.3 Approval tests

The welding consumables are approved subject to a satisfactory inspection of the Manufacturer's works by the Surveyor and to satisfactory results of approval tests.

The approval tests required are to be performed on samples of consumables representative of the production.

Sampling procedures are to be agreed with the Surveyor.

In general, the approval tests consist of the following checks:

- a) check of the operational characteristics of the consumable and its ability to produce substantially sound welds

- b) check of the mechanical properties of the deposited metal and welded joints and of the chemical composition of the deposited metal

- c) check of the hydrogen contents, where required

- d) check, at the request of the interested parties, of freedom from hot cracks, under specific test conditions.

Welding and inspection of the test samples and mechanical tests are to be carried out in the presence of the Surveyor.

The tests are to be carried out in laboratories and test rooms recognised by Tasneef

Unless otherwise specified, test specimens and procedures are to be in accordance with the applicable Society requirements or standards recognised by Tasneef

1.3.4 Certification

Upon satisfactory completion of the approval tests, a certificate of approval, stating the grade under which the consumable has been approved and the terms of validity of the approval, is issued by Tasneef to the Manufacturer.

The approved welding consumables and relevant grades are entered in the special lists of consumables approved by Tasneef

1.3.5 Annual inspections and tests

The workshops where approved materials are manufactured are subject to annual inspections by the Surveyor.

During the inspection, samples of the approved consumables are selected by the Surveyor and subjected to the tests detailed in the Articles relevant to the various products. These tests are to be repeated annually so as to provide an average of at least one test per year.

At Tasneef discretion, the consumables to be used in the above tests may be obtained, instead of from the Manufacturer as stated above, from users or dealers; the consumables are to be recently produced (in general less than 6 months).

Alternative procedures based on quality control and quality assurance systems may be considered and accepted subject to special approval by Tasneef which will state the relevant acceptance conditions on a case-by-case basis.

1.3.6 Manufacturer's responsibilities

After the approval has been obtained, and irrespective of the periodical tests carried out by Tasneef the Manufacturer is fully responsible for the quality of the finished product and compliance with the specified requirements, as verified in the approval and periodical control tests.

The Manufacturer is to keep up-to-date records of the manufacture of the approved consumables, including details of the history of the single productions and results of associated tests. Tasneef is to have free access to these records at all times.

The Manufacturer is responsible for reporting to Tasneef any major modifications introduced in the production procedure subsequent to its approval.

Full compliance on the part of the Manufacturer with all the requirements stated by Tasneef in connection with the approval of consumables is an essential condition for granting and renewing such approval.

1.3.7 Firms with several workshops or dealers

When consumables of the same brand are manufactured in different workshops belonging to the same Manufacturer, the complete series of tests is generally performed in one workshop only. In the other workshops, a reduced test program, as deemed appropriate in each case, is permitted if the Manufacturer certifies that the material used and the fabrication process are identical to those used in the main works.

The same applies to the approval and control tests of consumables already approved for one Manufacturer, when the consumables are transferred to another company for sale under a different brand name under the conditions specified by Tasneef

1.3.8 Changes in grading

Changes in grading of welding consumables are to be considered only at the Manufacturer's request, in general at the time of annual testing. For upgrading, tests from butt weld assemblies are generally required as a minimum in addition to normal annual tests, as specified here below.

For upgrading referring to impact properties, Charpy V-notch impact tests are to be performed at the upgrade temperature on the respective butt weld assemblies required for approval.

For upgrading referring to higher strength steels, all butt weld tests required for the approval are to be effected using higher strength steel as parent metal.

For upgrading referring to hydrogen content, tests according to [2.5] are to be carried out as appropriate.

Downgrading or withdrawal of the approval occurs when the prescribed tests and re-tests fail to meet the requirements.

1.3.9 Additional tests

Tasneef may, in some specific cases, request additional tests or requirements as deemed necessary.

1.4 Preparation and welding of test assemblies

1.4.1 Base material

The base material used for the test assemblies is to be of the steel grade appropriate to the consumable grade as specified in the various Articles.

For the preparation of all weld metal test assemblies, any grade of structural steel may be used. When the chemical composition of welded metal is substantially different from the base material, an overlay of side walls and backing strip may be carried out, as deemed necessary.

For the preparation of butt welded assemblies, steel grades are to be chosen depending on the grade of consumables.

When a welded joint is performed, the edges of the plates are to be bevelled either by mechanical machining or by oxygen cutting; in the latter case, a descaling of the bevelled edges is necessary.

1.4.2 Welding conditions and type of current

Welding conditions used, such as amperage, voltage, travel speed etc., are to be within the range recommended by the Manufacturer for normal good welding practice.

Where it is stated that a filler metal is suitable for both alternating current (a.c.) and direct current (d.c.), alternating current is to be used for welding the test assemblies for mechanical tests. When samples for checking the operating characteristics are required, both types of current are generally to be used. When samples for hot cracking tests are required, direct current is to be used.

Direct current is identified in the approval documentation with the symbols:

- CC+ or DCEP for positive electrode
- CC- or DCEN for negative electrode.

1.4.3 Post-weld heat treatment

Post-weld heat treatment of the welded assemblies is not allowed where the consumables are to be approved for the as welded condition only.

1.5 Mechanical tests

1.5.1 General

The test specimens for mechanical tests are to be taken from the welded assemblies as indicated in the various Articles; specimen preparation and test results are to comply with the requirements from [1.5.2] to [1.5.6].

The requirements relevant to the calibration of the equipment, preparation of test specimens and testing procedure, detailed in Ch 1, Sec 2, are also to be complied with, as appropriate.

1.5.2 Tensile tests

Round test specimens for longitudinal tensile tests and flat test specimens for transverse tensile tests are to be taken as described below:

a) round specimen:

The longitudinal axis is to coincide with the centre of the weld and mid-thickness of the weld in the all weld metal assemblies and second run in the two run welded assemblies. The diameter is to be 10 mm and other dimensions according to Ch 1, Sec 2, Fig 3; the specimen may be heated to a temperature not exceeding 250°C for a period not exceeding 16 hours, for hydrogen removal prior to testing.

The yield stress, tensile strength and elongation are to be determined and are to comply with the requirements specified for the various consumables; the reduction of area is to be determined and reported for information.

b) flat tensile specimen:

The test specimen is to be machined perpendicularly to the welded bead to the dimensions shown in Fig 1. The upper and lower surfaces of the weld are to be filed, ground or machined flush with the surface of the plate.

The tensile strength is to be determined together with the fracture position and is to comply with the requirements specified for the various consumables.

Figure 1 : Flat tensile test specimen

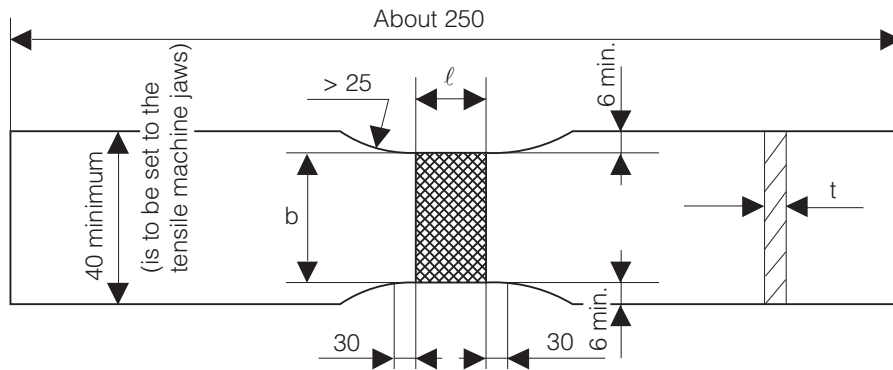

b = 12 mm for $t \leq 2$ mm
 b = 25 mm for $t > 2$ mm

1.5.3 Transverse bend tests

Face and root bend test specimens having 30 mm width and full plate thickness are to be machined transverse to the welded joint. The upper and lower surfaces of the weld are to be filed, ground or machined flush with the surface of the plate and the corners in tension rounded to a radius not exceeding 2 mm.

Two bend specimens are required; one specimen is to be tested with the face of the weld in tension and the other with the root of the weld in tension.

If the plate thickness exceeds 25 mm, it may be reduced to this size by machining on the compression side of the test specimen.

Alternatively, two side bend specimens may be taken in lieu of root and face bend specimens; side bend specimens may also be required in addition to or in lieu of root and face bend specimens for specific applications [1.5.4].

Bend test specimens are to be bent without fracture or cracks through an angle of 120°, unless a different angle is specified over a former having diameter as indicated in the various Articles; however superficial cracks or open defects not exceeding 3 mm may be disregarded.

1.5.4 Side bend tests

Side bend test specimens, having full plate thickness and width 10 mm, are generally required in addition to the root and bend tests for the approval of wire/gas combinations, and are required in lieu of the root and bend tests for electroslag or electroslag assemblies.

1.5.5 Longitudinal bend tests

When longitudinal face or root bend tests are required, test specimens in accordance with an appropriate standard are accepted.

1.5.6 Impact tests

Charpy V-notch impact specimens are to be cut with their longitudinal axis transverse to the weld joint and positioned as follows:

- a) for deposited metal and butt weld test assemblies with multi-run technique: at mid-thickness of the weld
- b) for two run welded test assemblies: on the second run side, 2mm below the surface

- c) for electroslag and electrogas welded test assemblies: 2 mm below the surface
- d) for one side automatic welding processes: 2 mm below the face side and 2 mm below the root side of the test assemblies; for thicknesses ≥ 30 mm, specimens at mid-thickness are also to be taken.

The notch is to be cut in the face of the specimen perpendicular to the surface of the plate and to be positioned in the centre of the weld. For electrogas and electroslag welding, an additional set with the notch at 2 mm from the fusion line in the weld metal is to be taken.

A set of three specimens is to be prepared and tested. The average impact energy is to comply with the values specified for the various consumables and only one individual value may be lower than the average required, provided it is not lower than 70% of it.

1.6 Test samples for checking the chemical composition of deposited weld metal

1.6.1 For some products (see [11], [12] [13]), the chemical composition of weld metal deposited with electrodes is required to be verified on samples welded for this purpose.

1.6.2 The test samples consist of a test plate of the specified steel having minimum sides 80x80 mm² and 15mm thickness.

On the above test plate, whose surface is to be cleaned by grinding to remove any trace of oxide, grease and paint, a weld pad is deposited in layers by welding in the flat position, each layer being formed by flanked beads. The minimum dimensions of the pad are to be as indicated in Tab 2.

Table 2 : Pad dimensions

Diameter of tested electrode (mm)	Minimum length and width of the pad (mm)	Minimum thickness of the pad (mm)
2,5	30 x 30	13
3,25 - max.	40 x 40	16

The width of each bead of each layer is to be 1,5 to 2,5 times the diameter of the electrode. It is recommended

that each layer should be deposited in a direction perpendicular to the previous one.

The current adopted for welding the test samples is to be within the range recommended by the Manufacturer; in the case of electrodes for use both with a.c. and d.c. current, the welding is to be carried out with alternating current.

After each layer has been deposited, the pad may be cooled to room temperature by immersion in water for 30 seconds.

The surface of each layer is to be free from slag inclusions and blow holes.

1.6.3 After the welding is completed, the top surface of the pad is to be removed by mechanical means and discarded.

Shavings sufficient for checking the chemical composition are then to be taken in such a manner that no metal is removed closer to the surface of the base plate than the distance indicated in Tab 3.

The use of lubricating oils during the mechanical machining for taking out the shavings is to be avoided.

Table 3 : Sampling method

Diameter of tested electrode (mm)	Minimum distance from the base plate for taking out the shavings (mm)
2,5	6
3,25 - max.	8

1.7 Re-test procedures

1.7.1 General

When for one or more test samples the execution of the weld, the external examination, the radiographic examination or the fracture produce results which are not considered satisfactory in some respects, and when the respective causes may be traced back to the operator or operating conditions, the test samples may be allowed to be repeated, in duplicate if deemed necessary, with the same procedure. In other cases, as well as when cracks are detected, the consumable will not be approved.

The operating conditions for the re-test samples are to be agreed with the Surveyor, as deemed appropriate.

For the approval of the consumable, or for the continuation of the testing program, the re-test samples are to produce satisfactory results.

1.7.2 Tensile and bend tests

Where the result of a tensile or bend test does not comply with the requirements, duplicate test specimens of the same type are to be prepared from the same sample and satisfactorily tested. Where insufficient original welded assembly is available, a new assembly is to be prepared using welding consumables of the same batch. If the new assembly is made with the same procedure (in particular the same number of runs) as the original assembly, only the duplicate re-test specimens need to be prepared and tested. Otherwise, all test specimens are to be prepared for re-testing.

1.7.3 Charpy V-notch impact test

For re-test procedures, reference is to be made to Ch 1, Sec 1, [3.5].

Further re-tests may be carried out at the Surveyor's discretion, but these are to be performed on a new welded assembly and are to include all the tests required for the original assembly, including those which were previously satisfactory.

2 Covered electrodes for manual metal arc welding of C and C-Mn steels

2.1 Application

2.1.1 General

The requirements of this Article apply to covered electrodes for manual metal arc welding of hull structural steels, of the corresponding grades of steel forgings and castings and of comparable steels intended for other structural applications or pressure systems.

2.1.2 Grading

Electrodes are divided, for the various strength levels, into the following grades:

- 1, 2, 3, 4 for normal strength steels
- 2Y, 3Y, 4Y, 5Y for high strength steels with specified minimum yield strength up to 355 N/mm²
- 2Y40, 3Y40, 4Y40, 5Y40 for high strength steels with specified minimum yield strength up to 390 N/mm².

Depending on the hydrogen content of the weld metal, the symbol H15 or H, H10 or HH, H5 is added to the grade mark as in [1.2.7].

The symbols H15, H10, H5 indicate the hydrogen content determined with the mercury method.

2.1.3 Information and documentation to be submitted

The following information and supporting documentation, as appropriate, are generally to be submitted together with the request for approval:

- trade name of the electrode
- range of diameters and other significant dimensions
- type of covering
- grades for which the application is made, including additional symbols
- typical chemical composition of the deposited metal
- weld metal recovery (efficiency) according to ISO 2401
- welding technique and type of current
- proposed range of application and operating characteristics
- marking and packing
- Manufacturer's workshop, manufacturing facilities, manufacturing and treatment cycles, methods and procedures of Manufacturer's quality controls
- instructions for use
- previous approvals granted to the electrodes with the necessary references.

Table 4 : Test samples for checking the operating characteristics

Type of test samples	Tee fillet joint		Circumferential butt-joint of pipe with horizontal axis
Welding position	Horizontal - vertical	Overhead	Fixed pipe
Operating conditions for welding the test samples			
Type of current for approval with both d.c. and a.c. (1)	a.c. for basic covered electrodes; d.c. for other types of electrodes		Both a.c. and d.c.
Welding technique	N.A.	N.A.	Upward (2)
Size of fillet weld (mm ²)	9 x 9		N.A.
Number of test samples and electrode diameters for approval in all welding positions (3)			
Number of test samples	1	1 (5)	1
Electrode maximum diameter for the 1st pass (mm)	4	4 (4)	2,5
Electrode diameter for remaining passes (mm)			3,25
<p>(1) For electrodes to be approved for use with d.c. or a.c. only, the test samples are to be welded with the current for which the approval has been requested.</p> <p>(2) For electrodes to be approved also for downward technique, the test sample is to be welded also with such technique.</p> <p>(3) For electrodes to be approved in one welding position only, the test samples are to be welded in the position for which the approval has been requested.</p> <p>(4) In the case of high efficiency (≥ 130) electrodes, electrodes having diameter 3,25 mm instead of 4 are to be used.</p> <p>(5) For electrodes to be approved only in flat and vertical positions, the sample is to be welded in vertical position.</p>			

Table 5 : Test assemblies and mechanical tests required

Test assembly						Tests required (1)
Type	Welding position (2)	Electrode diameter (mm) (3)	Number of samples	Thickness (mm)	Dimensions	
Deposited metal	Flat	4	1 (4)	20	Fig 4	1TL-3KV
		max.	1			
Butt weld	Flat	First run: 4 - Intermediate: 5 Last two layers: max	1 (5)	15 - 20	Fig 5	1TT-1RB-1FB-3KV
	Vertical upward	First run: 3,25 Remaining runs: 4	1			1TT-1RB-1FB-3KV
	Horizontal (6)	First run: 4 Remaining runs: 5	1			1TT-1RB-1FB-3KV
	Overhead	First run: 3,25 Remaining runs: 4	1			1TT-1RB-1FB
Fillet (7)		First side: min. diam.	1	15 - 20	Fig 7, Fig 8	Macro- Fracture- Hardness
		Second side: max.diam.				
<p>(1) Abbreviations: TL: longitudinal tensile test; TT: transverse tensile test; RB: root bend test; FB: face bend test; KV: Charpy V-notch impact test.</p> <p>(2) When the approval is requested only for one or more specified welding positions, the butt test samples are to be welded in such positions.</p> <p>(3) In the case of high efficiency (≥ 130) electrodes, electrodes having diameter 3,25 mm and 4 mm are to be used instead of 4 mm and 5 mm, respectively.</p> <p>(4) If only one diameter is to be approved, only one test assembly is required.</p> <p>(5) For electrodes to be approved in flat position only, an additional test sample is to be welded using electrodes having diameter 4 mm for the first pass, 5 mm for the second pass and the maximum diameter to be approved for the following passes.</p> <p>(6) The test sample in the horizontal position is not required when the same test sample is welded in flat and vertical positions.</p> <p>(7) See [2.6].</p>						

2.2 Approval tests

2.2.1 General

The approval tests specified in [1.3.3] are to be performed as indicated in [2.3] to [2.7] and summarised in Tab 4 and Tab 5.

2.3 Tests for checking the operating characteristics

2.3.1 General

The tests indicated in Tab 4 are required to be performed, at the discretion of T_{asneef} depending on the application and information submitted under [2.1.3].

The butt-joint tests of pipes are to be performed, in the specified position, only for electrodes which are considered as suitable for welding pipes.

2.3.2 Tee fillet joint

These test samples are required to verify that the electrode concerned, under the actual operational conditions and in the various welding positions for which the approval is requested, is capable of producing a sufficient weld penetration and a substantially sound weld.

The Tee-joint sample is to be welded with a single fillet, on two plates arranged and having the dimensions as shown in Fig 2.

For electrodes having diameter greater than 6 mm (5 mm, in the case of high efficiency electrodes), the test sample is to be 500 mm long and its plates 20 mm thick.

The vertical plate is to be perpendicular to the horizontal plate and a proper contact is to be obtained between the facing surfaces.

A single pass test fillet is to be deposited in one of the corners of the Tee; the fillet is to have dimensions $9 \times 9 \text{ mm}^2$.

It is recommended that the sample for the fracture test is completed by depositing two additional beads along the edges of the fillet, so as to force the fracture to occur in the throat section of the fillet (see Fig 2).

The fracture of the sample is to be obtained by suitable means aimed at closing the angle of the Tee where the fillet

weld has been deposited, so as to induce a tensile stress at the root of the fillet.

The examination of the surface of the fracture is to reveal a weld of sufficient penetration which is substantially sound, i.e. practically free of cracks or gas pockets; defects of operational nature, such as lack of fusion or slag inclusions, may be tolerated if they are on a small scale.

Possible defects located within 10 mm from the ends of the weld are disregarded.

2.3.3 Pipe butt-joint

The pipe butt-joint sample is made of two conferred lengths of pipe arranged and having the dimensions as shown in Fig 3. The two lengths of pipe are tack welded together and stiffened by means of two tack welded angles; the latter are to be scalloped in way of the pipe joint.

Upon completion of the tack welds, the maximum misalignment of the two pipes is not to exceed 1 mm.

As shown in Fig 3, the included angle of the bevel is to be 75° , with a root shoulder of about 1,5 mm; the bevels are to be machined.

All samples are to be welded with their axes in horizontal fixed position. However, depending on the welding positions and techniques for which the approval is requested, the samples may be welded in horizontal rotating position. The welding is to be performed with the usual technique, as appropriate in each case. The end craters of each pass and the tack welds at the bottom of the bevel may be eliminated by grinding.

After welding, the sample is to be subjected to radiographic examination.

The radiographic examination is to be performed after the removal of the internal stiffeners. The examination is to be effected with two elliptical radiographic pictures at 90° to each other, or another suitable method to the satisfaction of T_{asneef} .

The welded joint is to be without cracks; inclusions and porosities may be disregarded, provided they are on a small scale; local lack of penetration will be tolerated when the total length does not exceed 15 mm.

Figure 2 : Fillet weld assembly

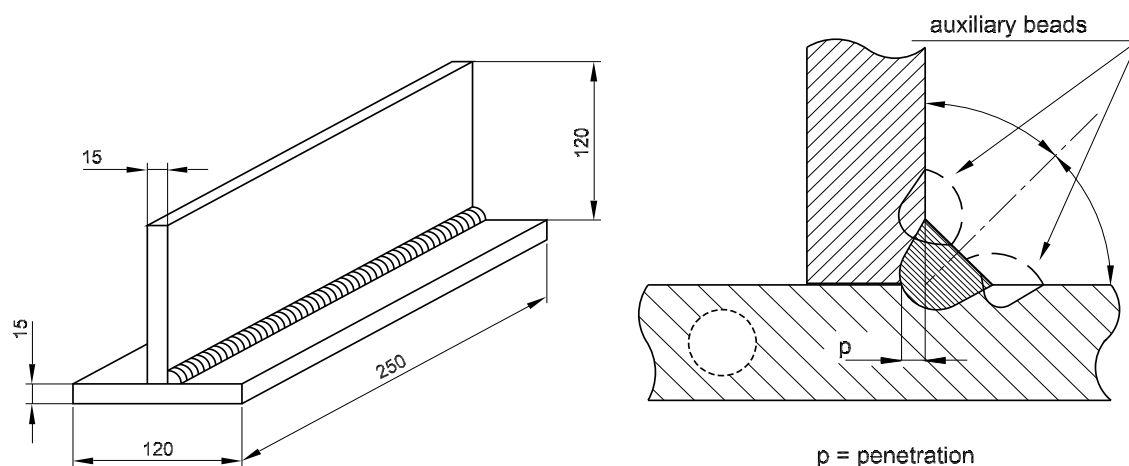
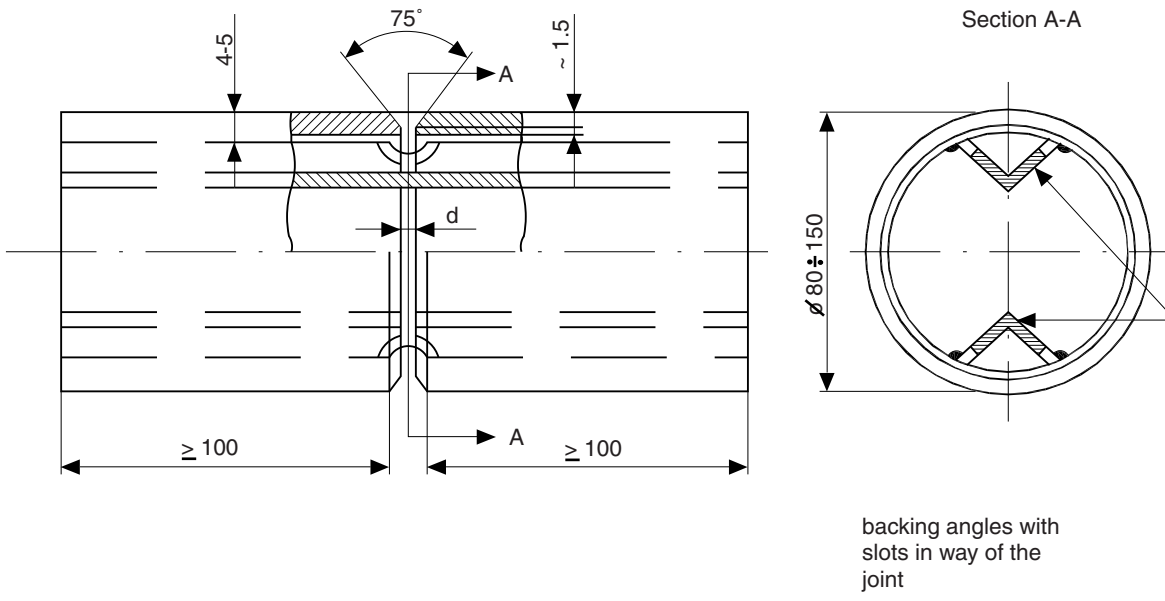
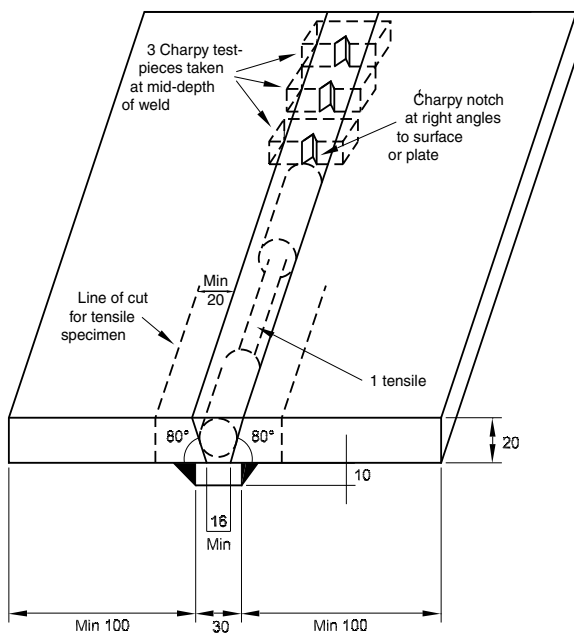

Figure 3 : Pipe assembly



d : electrode diameter for upward technique, in mm, equal to half the electrode diameter for downward technique.

Figure 4 : Deposited metal test assembly



All the dimensions are in mm, unless otherwise indicated.

2.4 Tests for checking the mechanical properties

2.4.1 General

The following tests indicated in Tab 5 are to be performed.

2.4.2 Deposited metal test assemblies

Two deposited metal test assemblies are to be welded in the flat position as shown in Fig 4, one with 4 mm diameter electrodes and the other with the largest size manufactured. If an electrode is available in one diameter only, one test

assembly is sufficient. Any grade of ship structural steel may be used for the preparation of the test assembly.

The weld metal is to be deposited in a single or multi-run layers according to normal practice, and the direction of deposition of each layer is generally to alternate from each end of the plate, each run of weld metal being not less than 2 mm and not more than 4 mm thick. Between each run the assembly is to be left in still air until it has cooled to less than 250°C but not below 100°C, the temperature being taken in the centre of the weld on the surface of the seam. After being welded, the test assemblies are not to be subjected to any heat treatment, except where approval has been requested also in the stress relieved condition [2.4.5]. In such case the symbol D is to be added to the grade designation.

The specimens shown in Fig 4 are to be taken for the following tests:

- one longitudinal tensile test
- three Charpy V-notch impact tests.

The results of the tests are to comply with the requirements of Tab 7, as appropriate.

The chemical analysis of the deposited weld metal in each test assembly is to be supplied by the Manufacturer and is to include the content of all significant alloying elements, if any.

2.4.3 Butt weld tests

Butt weld test assemblies as shown in Fig 5 are to be welded as indicated from a) to e).

- Flat position
 - one test sample welded using 4 mm electrodes for the first pass, 5 mm electrodes for the intermediate passes, and electrodes of the maximum diameter to be approved for the last two passes

- one test sample welded using 4 mm electrodes for the first pass, 5 mm electrodes for the second pass, and electrodes of the maximum diameter to be approved for the remaining passes. This additional test sample is required in the case of electrodes to be approved for the flat position only.

Figure 5 : Butt weld test assembly

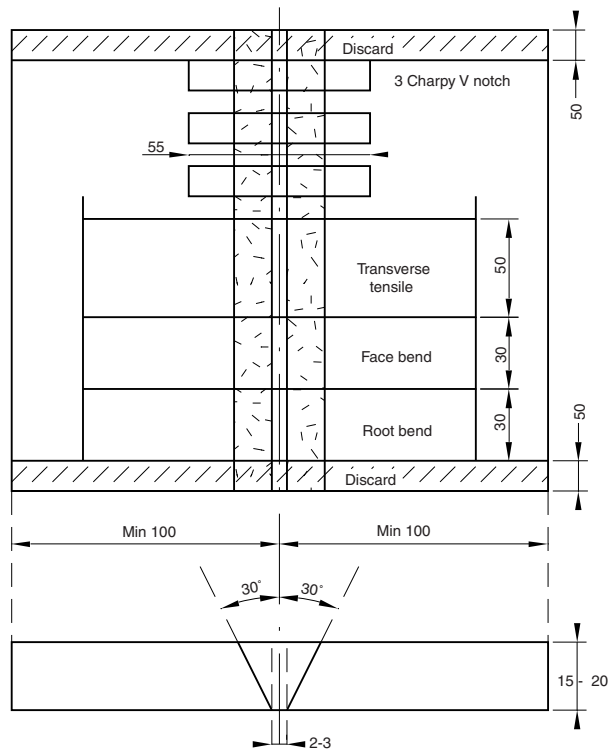

All the dimensions are in mm, unless otherwise indicated.

- Vertical position upward technique
 - one test sample welded using 3,25 mm electrodes for the first pass and 4 mm electrodes for the remaining passes, or 5 mm if this is recommended by the Manufacturer for welding in vertical position
- Vertical position downward technique
 - one test sample welded using electrode diameters recommended by the Manufacturer, when the approval with the downward technique has been requested
- Overhead position
 - one test sample welded using 3,25 mm electrodes for the first pass and 4 mm electrodes (or possibly 5 mm if this is recommended by the Manufacturer) for the remaining passes
- Horizontal position
 - one test sample welded using 4 mm electrodes for the first pass and 5 mm electrodes for the remaining passes. This test sample need not be welded in the

case of electrodes for which the execution of the same test sample in flat and vertical positions is required.

The grade of steel to be used for the preparation of the test assemblies is related to the grade of the electrodes as indicated in Tab 6.

For electrodes to be approved under grades 4 and 5, in lieu of the hull steels specified in Tab 6, C-Mn steels for pressure vessels of grades L40 and L60, respectively, and strength appropriate to the electrode strength may be used.

The use of other type of steel is to be agreed with Tasneef on a case-by-case basis.

Table 6 : Grade of steel used for test assemblies

Electrode grade	Steel grade (1)
1	A
2	A, B, D
3 - 4	A, B, D, E
2Y	AH32-36, DH32-36
3Y	AH32-36, DH32-36, EH32-36
4Y- 5Y	AH32-36, DH32-36, EH32-36, FH32-36
2Y40	AH40, DH40
3Y40	AH40, DH40, EH40
4Y40 - 5Y40	AH40, DH40, EH40, FH40
(1) The tensile strength of grades AH32 to FH32 is to be greater than 490 N/mm ² .	

The welding is to be performed with the usual technique in compliance with the requirements specified in [2.4.2] for the deposited metal test, as applicable. For all assemblies, the back sealing run is to be made with 4 mm diameter electrodes, in the welding position appropriate to each test sample, after back gouging to sound metal. For electrodes suitable for downhand welding only, the test assemblies may be turned over to carry out the backing seal.

After being welded, the test assemblies are not to be subjected to any heat treatment except where approval has been requested also in the stress relieved condition [2.4.5]. In such case the symbol D is to be added to the grade designation.

It is recommended and may be required that the welded assemblies should be subjected to a radiographic examination to ascertain if there are any defects in the weld prior to the preparation of test specimens.

The test specimens shown in Fig 5 are to be taken for the following tests:

- one transverse tensile test
- three Charpy V-notch impact tests
- one root and one bend test specimen.

Table 7 : Mechanical properties

Grade	Longitudinal tensile test on deposited metal			Tensile test on butt weld	Charpy V-notch impact test Minimum average energy (J)		
	Yield stress R_{eH} (N/mm ²) min.	Tensile strength R_m (N/mm ²)	Elong A_5 (%) min.	Tensile strength R_m (N/mm ²) min.	Test temp. (C°)	Flat, Horizontal, Overhead	Vertical
1	305	400 - 560	22	400	+ 20	47	34
2					0		
3					- 20		
4					- 40		
2Y	375	490 - 660	22	490	0	47	34
3Y					- 20		
4Y					- 40		
5Y					- 60		
2Y40	400	510 - 690	22	510	0	47	39
3Y40					- 20		
4Y40					- 40		
5Y40					- 60		41

2.4.4 Test requirements

The required results of tensile and impact tests on deposited metal and butt weld tests are indicated in Tab 7.

Bend tests are to be performed on a mandrel having a diameter equal to three times the thickness of the specimen; the results are to comply with requirements in [1.5.3].

2.4.5 Approval in the stress relieved condition

When the approval of the electrode is required with the additional symbol D, relevant to the checking of the mechanical properties in the stress relieved condition, the following additional tests are to be performed on samples submitted to stress relieving in the furnace for 1 hour at 600-650°C:

- one longitudinal tensile test and 3 Charpy V-notch impact tests on the deposited metal test assembly welded with the maximum diameter to be approved
- alternatively or in addition, at the Surveyor's discretion, 3 Charpy V-notch impact tests on the butt weld test welded in flat and vertical position.

The impact tests are to be carried out at the temperature specified for the respective grades of electrodes.

2.5 Tests for checking the hydrogen content

2.5.1 General

When electrodes are to be approved with symbol H or H15, HH or H10, H5, tests are to be carried out to determine the hydrogen content of the weld metal.

Low hydrogen electrodes are to be subjected to a hydrogen test.

The hydrogen content is to be checked with the mercury method according to ISO standard 3690-1977 or another comparable method with Tasneef consent. The use of the

glycerine method described in [2.5.2] may be admitted by Tasneef for symbols H and HH. For the assignment of the designation HHH, the hydrogen content is, in any case, to be checked with the mercury method according to the above ISO standard.

2.5.2 Glycerine method

Four test samples are to be prepared measuring 12 x 25 mm² in cross-section by about 125 mm in length. The parent metal may be any grade of structural steel and, before welding, the samples are to be weighed to the nearest 0,1 gram. On the 25 mm width surface of each specimen, a single bead of welding is to be deposited by a 4 mm electrode burning a length of about 150 mm of the electrode. The welding is to be carried out with an arc as short as possible and with current of about 150 amp. Alternating current a.c. is to be used when the electrode is proposed for approval with both a.c. and d.c. Before welding, the electrodes may be submitted to the normal drying process recommended by the Manufacturer.

The procedure for determining the hydrogen content is as follows:

- within 30 seconds after the completion of the weld, the slag is to be removed and the samples quenched in water at approximately 20°C
- after 30 seconds in water, the samples are to be cleaned and deposited in an apparatus suitable for the collection of the hydrogen by the displacement of glycerin (or paraffin). During the test, the glycerin is to be maintained at 45°C. All four samples are to be welded and subjected to the hydrogen test within 30 minutes.
- the samples are to be kept soaking in glycerin for 48 hours; after being removed from the machine, the samples are to be cleaned by means of water and alcohol,

dried and weighed to the nearest 0,1 gram in order to determine the amount of deposited metal

- d) the amount of gas developed is to be measured to the nearest 0,05 cm³ and corrected for temperature and pressure to 20°C and 760 mm Hg, respectively;
- e) the individual and average diffusible hydrogen content of the four specimens is to be reported and the average value in cm³, per 100 grams of deposited metal, is not to exceed the values specified for the symbol of the electrode concerned.

2.5.3 Hydrogen test requirements

The hydrogen content determined with the mercury or glycerine test is not to exceed the values given in Tab 8.

Table 8 : Diffusible hydrogen content of weld metal

Symbol	Mercury method	Glycerine method
H15 (H)	15	10
H10 (HH)	10	5
H5	5	(1)
(1) Glycerine method is not allowed		

2.6 Fillet weld test assemblies

2.6.1 Fillet weld test assemblies are required for electrodes submitted for approval for fillet welding only and may be required, during the first approval tests at the Surveyor’s discretion, for electrodes submitted for approval for both butt and fillet welding. In the latter case, only one sample in horizontal-vertical position is generally to be welded.

When the electrode is proposed for fillet welding only, fillet weld assemblies for each welding position (horizontal-vertical, vertical upward, vertical downward or overhead) recommended by the Manufacturer and deposited weld metal test as indicated in [2.4.2] are to be welded. The test assemblies, as shown in Fig 6, are to have a length L sufficient to allow at least the deposition of the entire length of the electrode being tested.

Plates in normal hull structural steel having thickness 15-20 mm are used.

Figure 6 : Fillet weld test assembly

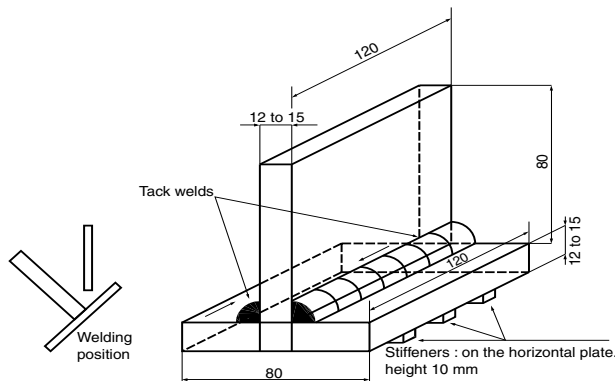

2.6.2 The test sample is to be welded on both sides; the first side is to be welded with the maximum diameter and

the second side with the minimum diameter. The sizes of the beads are about 9x9 and 6x6 mm² for the first and second beads, respectively.

2.6.3 After visual examination and assessment, three sections for macrographic examination are to be taken from each test sample as indicated in Fig 7 (one in the middle and one at each end). These are to be examined for root penetration, satisfactory profile, freedom from cracking and reasonable freedom from porosity and slag inclusions.

Figure 7 : Sections for micrographic examination

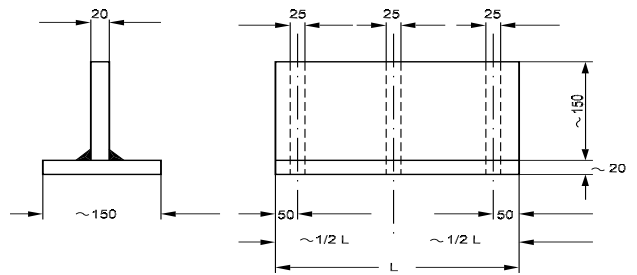

Vickers hardness measurements are to be carried out to the Surveyor’s satisfaction on the above sections in the positions indicated in Fig 8.

Figure 8 : Hardness readings

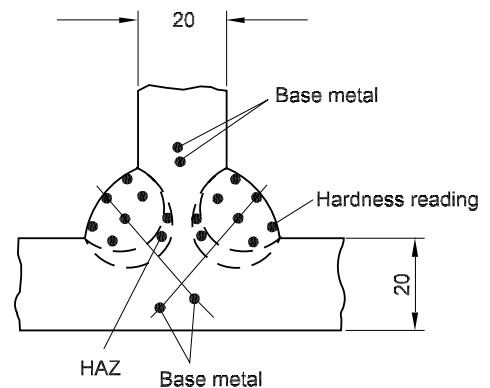

The dimensions are in mm.

The hardness of the weld metal obtained is to be:

- ≥ 120 HV for normal strength level
- ≥ 150 HV for high strength level up to R_{eH}=355 N/mm²
- ≥ 170 HV for high strength level up to R_{eH}=390 N/mm².

The hardness of both heat affected zone H.A.Z. and base metal is also to be determined and is to be reported for information.

2.6.4 The two parts obtained upon sectioning the sample are to be subjected to fracture as in [2.3.2] after having previously removed the welding bead from one side (on one part the first and on the other the second deposited beads).

The fractured surfaces are to be examined for root penetration, satisfactory profile, freedom from cracks and reasonable freedom from porosity.

2.6.5 These tests may partially replace the T fillet joints when required in [2.3.2].

2.7 Annual control tests

2.7.1 The annual tests are to include at least the following:

- a) two deposited metal test assemblies are to be prepared in accordance with [2.4.2] and the required tests (one longitudinal tensile test and 3 Charpy V-notch impact tests) are to be conducted. For electrodes approved for fillet weld only, and not suitable for butt-joints, only one deposited metal test with the maximum diameter is to be carried out.
- b) at the discretion of *Tasneef* a butt weld test to be welded in vertical position may be required in lieu of the deposited metal test with electrodes of 4 mm
- c) the check of the hydrogen content may be required for electrodes approved with symbol HH or H10 and H5.
- d) the chemical composition may be required to be checked under conditions corresponding to those of the approval tests

The welding and test procedures, the type of current, the materials, the test results and the re-test procedures, where applicable, are regulated by the requirements relative to the approval tests.

3 Covered electrodes for gravity or contact welding

3.1 Application

3.1.1 The requirements of this Article apply to covered electrodes when submitted for approval for use in gravity welding, using automatic gravity or similar welding devices.

3.2 Approval tests

3.2.1 Where the electrode is submitted for approval for the gravity welding technique only, deposited metal tests [2.4.2], fillet weld tests [2.6] and, where appropriate, butt weld tests [2.4.3] similar to those for manual electrodes are to be carried out with such technique.

3.2.2 Where the electrode is submitted for approval for the gravity welding technique in addition to normal manual welding, fillet weld tests and, where appropriate, butt weld tests are to be carried out with the gravity process, in addition to the normal approval tests.

3.2.3 The fillet weld test is to be gravity welded using the longest size of electrode manufactured. The Manufacturer's recommended current range is to be reported for each electrode size.

The results of the tests are to comply with the requirements specified in [2.6.3] and [2.6.4].

3.3 Annual control tests

3.3.1 Where the electrode is approved only for gravity welding, the annual test is to consist of at least one deposited weld metal test assembly using such process. If the

electrode is approved also for manual arc welding, the annual test is to be performed as indicated in [2.7.1].

4 Covered electrodes for deep penetration manual welding of C and C-Mn steels

4.1 Application

4.1.1 The requirements of this Article apply to deep penetration electrodes to be used for downhand butt and fillet welding and horizontal-vertical fillet welding.

Deep penetration electrodes may be approved as grade 1 electrodes only and are to be given the additional symbol D.P.

Approvals limited to butt-joints only may be considered. In these cases, the test sample specified in [4.2.2] is not required.

4.1.2 The welding of butt-joints in flat position is to be performed on square groove edges.

When the Manufacturer requires that the approval is extended to cover butt-welded joints having a single Vee edge preparation, all the tests required in [2] for normal type electrodes used in flat position are to be carried out, in addition to the tests required in this Article.

4.1.3 Test samples relative to the approval of deep penetration electrodes are to be welded with the type and the intensity of current recommended by the Manufacturer.

When it is intended that the approval is valid for use with both d.c. and a.c. currents, the test samples are to be welded with a.c. current.

4.1.4 As regards the procedure for the approval, the preparation and welding of samples, the specimens and testing, the requirements specified in [2] for ordinary electrodes are to be complied with, in so far as applicable.

4.2 Approval tests

4.2.1 Butt weld test assembly

The following test sample in grade A structural steel or equivalent steel to the Surveyor's satisfaction is to be welded:

- one butt-welded sample, with square groove edges, made of two plates having width ≥ 100 mm and a thickness equal to twice the diameter of the core of the electrode plus 2 mm; such sample is to be welded in flat position with the maximum electrode diameter for which the approval has been requested, with a single pass on each side (see Fig 9).

The edges are to be accurately cut and in good contact (not more than 0,25 mm between edges for the full length of the joint).

The specimens for the following tests are to be taken after having discarded a length of 35 mm from each end:

- two transverse tensile tests
- one face and one root bend

- three Charpy V-notch impact tests
- two macrographic examinations.

Figure 9 : Deep penetration butt weld test assembly

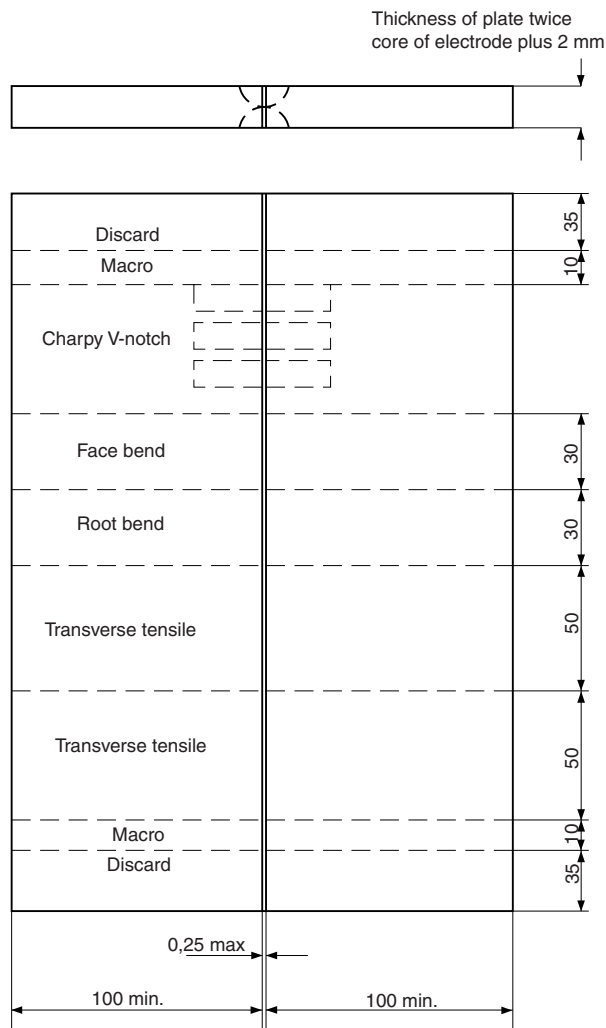

All the dimensions are in mm.

4.2.2 Fillet weld test assembly

The following test sample in grade A structural steel or equivalent steel to the Surveyor's satisfaction is to be welded:

- one Tee-joint sample having length ≥ 160 mm and thickness about 12-15 mm, to be welded in horizontal position with a 4 mm electrode on one side and with an electrode of the maximum diameter to be approved on the other side.

The edges are to be accurately cut and the gap between the plates is to be not more than 0,25 mm for the full length of the joint as shown in Fig 10.

Two cross-sections are to be obtained from the sample at about 35 mm from each end; the two cross-sections are to be subjected to a macrographic examination (see Fig 10).

Figure 10 : Deep penetration fillet weld test assembly

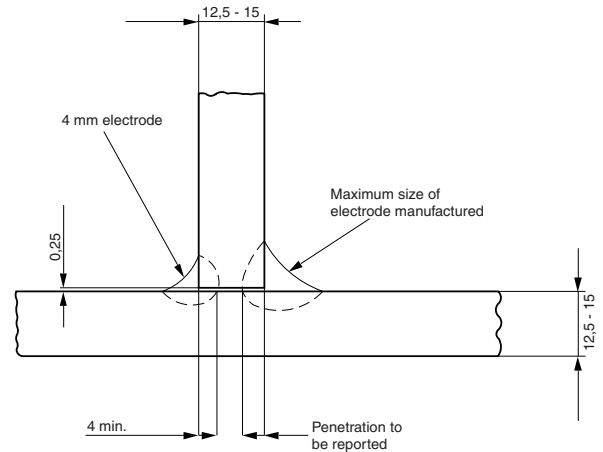

4.2.3 Test requirements

The results required for the tests mentioned in [4.2.1] and [4.2.2] are specified in the following items a) and b):

a) Butt weld test assembly:

- bend tests on a mandrel having diameter equal to three times the thickness of the sample: bend angle $\alpha \geq 120^\circ$
- transverse tensile test: $R_m \geq 410$ N/mm²
- impact tests at about +20°C; minimum absorbed energy (average value of three tests): KV ≥ 47
- the macrographic examinations are to show a complete compenetration of the welds on the two sides.

b) Fillet weld test assembly:

- the fillet deposited with the 4 mm electrode is to show a penetration not less than 4 mm (see Fig 10)
- the penetration obtained by the fillet deposited with the maximum diameter of electrode on the other side is to be measured and reported for information purposes only.

4.2.4 Maximum thickness which can be welded

Upon satisfactory completion of the tests mentioned in the above paragraphs, the Manufacturer is to prepare and submit to Tasneef a table showing the maximum thickness which can be welded, with square groove edges, with each diameter of electrode included in the approval and with the intensity of current necessary for the relevant electrode.

The table, which forms an integral and essential part of the approval documentation, is to substantially conform to the maximum thickness value verified in the test in [4.2.1].

Table 9 : Wire chemical composition

Type of wire	Chemical composition									
	C max.	Mn	Si max.	P max.	S max.	Al max.	Cr max.	Ni max.	Cu max.	Mo
1	0,13	0,40 - 0,65	0,15 (2)	0,03	0,03	0,03	0,15	0,25	0,30	(3)
2	0,15	0,80 - 1,20								
3	0,15	1,30 - 1,70								
4	0,15	1,80 - 2,20 (1)								
5	0,16	2,30 - 2,70								

(1) A content lower by not more than 0,05% is acceptable.
(2) Wires having chemical composition 1 may be of rimmed steel; the other wires may be of Si and/or Al killed or semi-killed steels. Approval may be granted to wires having Si content up to 0,40%, depending on the type of wire concerned.
(3) For all wires Mo may be included in the proposed composition in the range 0,45-0,60 %; the content is to be stated by the Manufacturer at the time of the request for approval of the wire-flux combination.

4.3 Annual control tests

4.3.1 One test sample, as illustrated in Fig 9 or Fig 10 as applicable, is required; such sample is to be welded with electrodes having the maximum approved diameter.

The required tests and the relevant requirements are those indicated in [4.2.1], [4.2.2] and [4.2.3]; however, only one transverse tensile test is required.

For electrodes approved for both normal and deep penetration welding in the downhand position, a deep penetration weld test, as above, is to be carried out in addition to the deposited weld metal tests required for normal penetration.

5 Flux-wire combination for submerged arc welding of C and C-Mn steels

5.1 Application

5.1.1 General

The requirements of this Article apply to wire flux combination for submerged arc welding of hull structural steels, of the corresponding grades of steel forgings and castings and of comparable steels intended for other structural applications or pressure systems.

Approvals granted in accordance with these requirements are valid for standard single wire welding.

Other techniques, such as tandem or multi-wire welding, and one side welding on flux or backing, are to be submitted to separate approval tests. These tests are generally to be carried out in accordance with the requirements of this Article and are detailed, on a case-by-case basis, depending on the welding procedure proposed.

5.1.2 Type of wires

Types of wires identified by the chemical composition shown in Tab 9 are generally to be used.

The flux Manufacturer is to submit to Tasneef for consideration, wires having chemical composition other than those given in Tab 9 .

The wire Manufacturer is jointly responsible with the flux Manufacturer for the compliance of the wire with the chemical composition specified at the time of approval.

5.1.3 Grading

Wire flux combinations are divided, for the various strength levels, into the following grades:

- 1, 2, 3, 4 for normal strength steels
- 1Y, 2Y, 3Y, 4Y, 5Y for high strength steels with specified minimum yield strength up to 355N/mm²
- 2Y40, 3Y40, 4Y40, 5Y40 for high strength steels with specified minimum yield strength up to 390N/mm².

Depending on the welding technique, the following symbols are added:

- T for use with two-run technique
- M for use with multi-run technique
- TM for use with both techniques
- U for one side technique.

5.1.4 Information and documentation to be submitted

The following information and supporting documentation, as applicable, are generally to be submitted together with the request for approval:

- commercial name of the flux, for which the approval is requested; type of flux (fused or conglomerate), typical analysis, type and size of granules (for fused fluxes)
- commercial name of the associated wire, limits of chemical composition and diameters to be approved; producer, supplier, conditions under which it is supplied (surface protection, diameters and weight of the standard coils)
- welding technique and grading under which the approval is requested; type of current and maximum current values for which the approval is requested
- typical chemical composition of the deposited metal, with particular reference to the contents of Mn, Si and

- alloying elements, which are to be specified in all cases; conditions to which the chemical composition refers
- indications, where applicable, regarding the range of the welding parameters (current, voltage and welding speed)
 - information regarding the efficiency of the wire-flux combination submitted for approval
 - recommended preparation for butt-joints of various thicknesses; recommendations and limitations on wire stick out if any
 - packaging and labelling (marking)
 - Manufacturer's workshop, manufacturing facilities, manufacturing and treatment cycles, methods and procedures of Manufacturer's quality controls
 - instructions and recommendations before using the flux (backing), as applicable
 - previous approvals granted to the proposed wire-flux combination.

5.2 Approval tests

5.2.1 General

The test assemblies required for approval are specified in [5.2.2] to [5.2.7] and summarised in Tab 10, depending on the welding technique to be approved.

A few preliminary samples may be required by the Surveyor to be welded, in order to check the operating characteristics and set up the welding parameters.

5.2.2 Multi-run technique (M)

Where approval for use with multi-run technique is requested, deposited weld metal and butt weld tests are to be carried out as indicated in [5.2.3] and [5.2.4], respectively.

5.2.3 Deposited metal test

One deposited metal test is to be welded, as shown in Fig 11, in general with a wire having diameter of 4 mm.

Any grade of ship structural steel may be used for the preparation of the test assembly.

The welding conditions (amperage, voltage and travel speed) are to be in accordance with the recommendations of the Manufacturer and are to conform with normal good welding practice.

Figure 11 : Deposited metal test

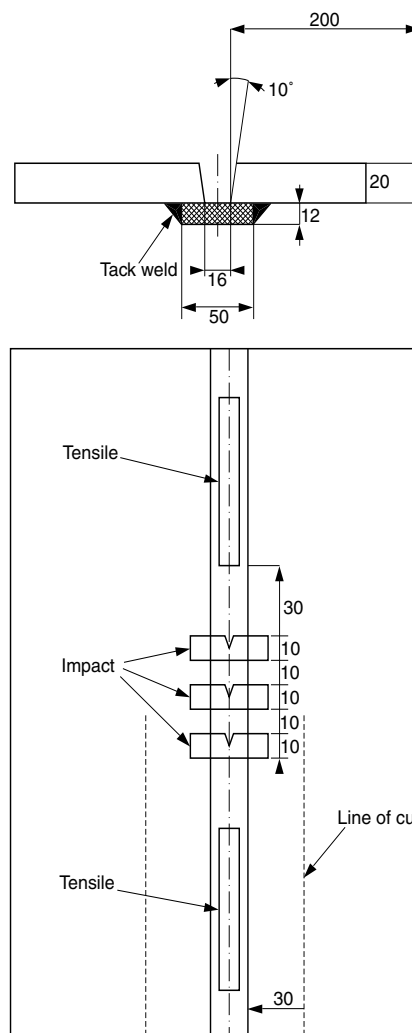

All the dimensions are in mm, unless otherwise indicated.

Table 10 : Test assemblies and mechanical tests required

Welding technique	Test assembly				Tests required (1)
	Type	Number	Thickness (mm)	Dimensions	
M	Deposited metal test	1	20	Fig 11	2TL - 3KV
	Butt weld test	1	20 - 25	Fig 12	2TT - 2RB - 2FB - 3KV
T	Butt weld test	1	12 - 15	Fig 14	2TT - 1RB - 1FB - 3KV
	Butt weld test	1	20 - 25	Fig 14	1TL - 2TT - 1RB - 1FB - 3KV
	Butt weld test	1	30 - 35	Fig 14	1TL - 2TT - 1RB - 1FB - 3KV
TM	(2)	(2)	(2)	(2)	(2)

(1) Abbreviations: TL = longitudinal tensile test; TT = transverse tensile test; RB = root bend test; FB = face bend test; KV = Charpy V-notch impact test.

(2) Test assembly and tests for both techniques are required; only one longitudinal tensile test is required on the deposited metal test.

The weld metal is deposited in multi-run layers and the direction of deposition of each layer is in general to alternate from each end of the plate. After completion of each run, the flux and welding slag are to be removed. Between each run, the assembly is to be left in still air until it has cooled to less than 250°C but not below 100°C, the temperature being taken in the centre of the weld on the surface of the seam. The thickness of each layer is to be neither less than the diameter of the wire nor less than 4mm. After being welded, the test assemblies are not to be subjected to any heat treatment, except where approval has also been requested in the stress relieved condition. In such case the symbol D is to be added to the grade designation.

The specimens shown in Fig 11 are to be taken for the following tests:

- a) two longitudinal tensile tests
- b) three Charpy V-notch impact tests.

The results of the tests are to comply with the requirements of Tab 13, as appropriate.

The chemical analysis of the deposited weld metal of the test assembly is to be supplied by the Manufacturer and is to include the content of all significant alloying elements, if any.

Figure 12 : Butt weld test assembly

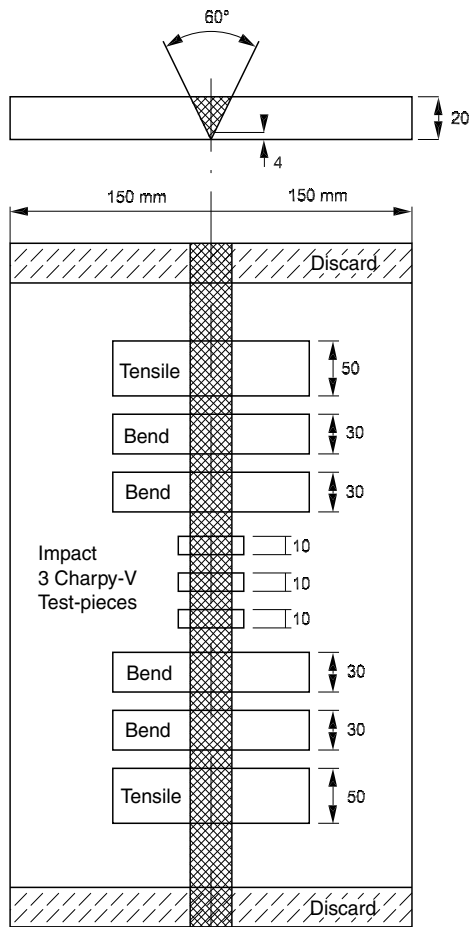

All the dimensions are in mm, unless otherwise indicated.

5.2.4 Butt weld tests for multi-run technique

One butt weld test assembly is to be welded as shown in Fig 12 in general with a wire having diameter of 4 mm.

The grade of steel to be used for the preparation of the test assemblies is related to the grade of the wire-flux combination as indicated in Tab 11.

Table 11 : Grade of steel used for test assemblies

Wire flux combination grade	Steel grade (1)
1	A
2	A, B, D
3 - 4	A, B, D, E
1Y	AH 32-36
2Y	AH 32-36, DH 32-36
3Y	AH32-36, DH32-36, EH32-36
4Y - 5Y	AH32-36, DH32-36, EH32-36, FH32-36
2Y40	AH40, DH40
3Y40	AH40, DH40, EH40
4Y40 - 5Y40	AH40, DH40, EH40, FH40

(1) The tensile strength of grades AH32 to FH32 is to be greater than 490 N/mm² .

At the discretion of Tasneef approval of multi-run welding of both normal and higher strength steel may be obtained by making a butt weld on higher tensile steel only.

For flux to be approved under grades 4 and 5, in lieu of the hull steels specified in Tab 11, C-Mn steels for pressure vessels of grades L40 and L60, respectively, and strength appropriate to the wire flux combination strength may be used .

The use of other types of steel is to be agreed with Tasneef on a case-by-case basis.

The welding is to be performed by the multi-run technique and the welding conditions are to be the same as those adopted for the deposit weld metal assembly. The back sealing run is to be made with the welding parameters used for the filling pass, after back gouging to sound metal.

After being welded, the test assemblies are not to be subjected to any heat treatment except where approval has also been requested in the stress relieved condition [5.2.7]. In such case the symbol D is to be added to the grade designation.

It is recommended that the welded assemblies should be subjected to a radiographic examination to ascertain if there are any defects in the weld prior to the preparation of test specimens.

The test specimens, shown in Fig 12, are to be taken for the following tests:

- a) two transverse tensile tests
- b) three Charpy V-notch impact tests
- c) two root and two bend tests.

The results of the tests are to comply with the requirements of [5.2.6], as appropriate.

Table 12 : Two-run technique butt weld test assemblies

Grade	Plate thickness (mm)	Recommended preparation (2)	Maximum diameter of wire (mm)
1 - 1Y	12 - 15	Fig 13 (a)	5
	20 - 25	Fig 13 (b)	6
2, 3, 4, 2Y, 3Y, 4Y, 5Y, 2Y40, 3Y40, 4Y40, 5Y40	20 - 25 (1)	Fig 13 (b)	6
	30 - 35 (1)	Fig 13 (c)	7

(1) A limitation of the approval to the lower and medium thickness range (up to the maximum welded plate thickness) may be agreed to by *Tasneef* and the test pieces are then to be welded from plates of thickness 12-15 mm and 20-25 mm, irrespective of the quality grade.

(2) Minor deviations in the weld preparation are admissible; the root gap is to be practically constant and generally is not to exceed 0,7 mm.

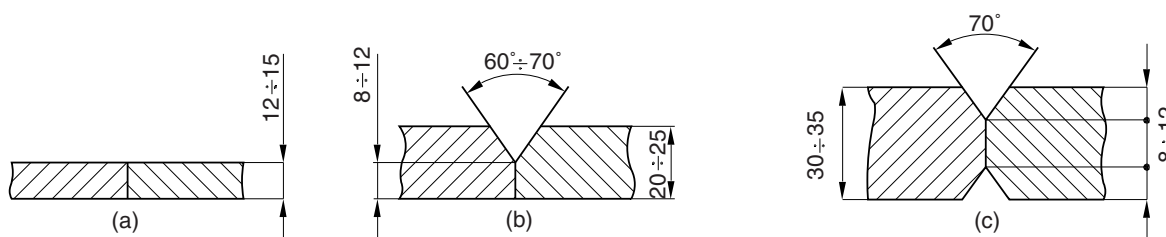
Figure 13 : Recommended edge preparation for two-run technique

5.2.5 Two-run technique (T)

Where approval for use with two-run technique only is requested, two butt weld test assemblies are to be carried out as indicated in Tab 12 and no deposited metal test is requested.

The grade of steel to be used for the preparation of the test assemblies is related to the grade of the wire flux combination as indicated in Tab 11.

Each strength level requires separate approval.

For flux to be approved under grades 4 and 5, in lieu of the hull steels specified in Tab 11, C-Mn steels for pressure vessels of grades L40 and L60, respectively, and strength appropriate to the wire flux combination strength may be used.

The use of other types of steel is to be agreed with *Tasneef* on a case-by-case basis.

The welding is to be performed in two runs, one from each side, using voltage and travel speed in accordance with the recommendation of the Manufacturer and normal good welding practice. In general, the following values of current parameters are to be complied with for welding the second run:

- 700-800 A for samples having thickness 12-15 mm
- 900-1000 A for samples having thickness 20-25 mm
- 1100-1200 A for samples having thickness 30-35 mm.

After the completion of the first run, the flux and welding slag are to be removed and the assembly left in still air until it has cooled to 100°C, the temperature being taken in the centre of the weld, on the surface of the seam.

After being welded, the test assemblies are not to be subjected to any heat treatment except where approval has also been requested in the stress relieved condition. In such case the symbol D is to be added to the grade designation.

The test assemblies are to be subjected to radiographic examination to ascertain freedom from lack of penetration or other defects in the weld, prior to the preparation of test specimens.

The test specimens, shown in Fig 14, are to be taken for the following tests:

- two transverse tensile tests
- three Charpy V-notch impact tests
- one root and one bend test.

Where the approval is required for two-run technique only, one longitudinal tensile specimen is to be taken from the thicker plate, as shown in Fig 14.

The results of the tests are to comply with the requirements of [5.2.6], as appropriate.

The chemical analysis of the weld metal of the second run in each test assembly is to be supplied by the Manufacturer and is to include the content of all significant alloying elements, if any.

5.2.6 Tests requirements

The required results of tensile and impact tests on deposited metal and butt weld tests are indicated in Tab 13.

Bend tests are to be performed on a mandrel having a diameter equal to three times the thickness of the specimen; the results are to comply with requirements in [1.5.3].

Table 13 : Required mechanical properties

Grade	Longitudinal tensile test on deposited metal			Tensile test on butt weld	Charpy V-notch impact test	
	Yield stress R_{eH} (N/mm ²) min.	Tensile strength R_m (N/mm ²)	Elong. A_5 (%) min.	Tensile strength R_m (N/mm ²) min.	Test temp. (°C)	Minimum average energy (J)
1	305	400 - 560	22	400	+ 20	34
2					0	
3					- 20	
4					- 40	
1Y	375	490 - 660	22	490	+ 20	34
2Y					0	
3Y					- 20	
4Y					- 40	
5Y					- 60	
2Y40	400	510 - 690	22	510	0	39
3Y40					- 20	
4Y40					- 40	
5Y40					- 60	41

Figure 14 : Butt weld test assembly for two-run technique

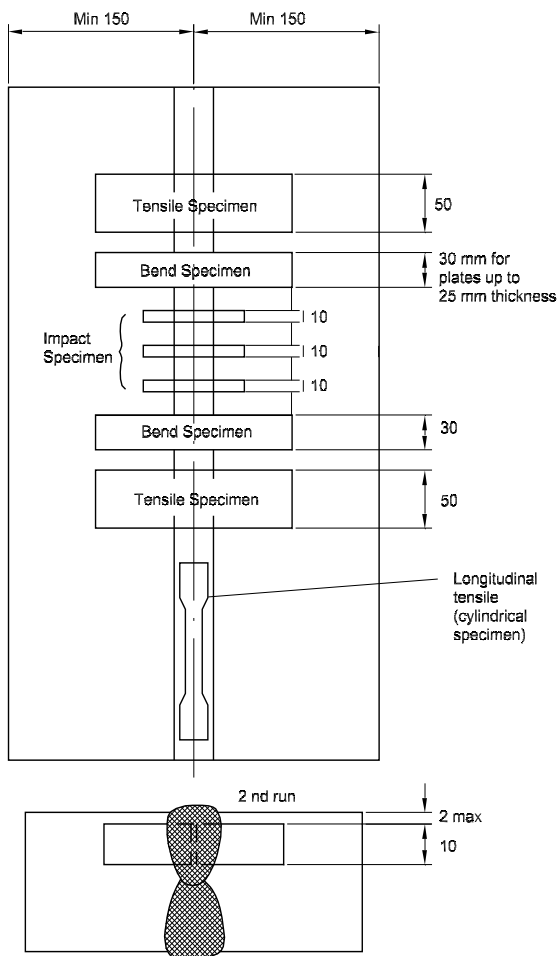

All the dimensions are in mm.

5.2.7 Approval in the stress relieved condition

When the approval of the wire flux combination is required with the additional symbol D, relevant to the checking of the mechanical properties in the stress relieved condition, the following additional tests are to be carried out on samples submitted to stress relieving in the furnace for one hour at 600-650°C:

- a) Two-run technique (T)
 - one longitudinal and one transverse tensile test, three Charpy V-notch impact tests on the face and root side of the butt welded assembly having the maximum thickness.
- b) Multi-run technique (M)
 - one longitudinal tensile test on the deposited metal test and one transverse tensile test on the butt weld test
 - three Charpy V-notch impact tests on deposited metal and butt weld tests.

5.3 Annual control tests

5.3.1 The periodical control tests are to include at least the following:

- a) Two-run technique (T)
 - one butt weld test assembly with plate thickness 20-25 mm from which one transverse tensile, two bend tests (one root and one face bend) and three impact tests are to be taken. One longitudinal tensile test is also to be prepared for wire flux combinations approved solely for the two-run technique.
- b) Multi-run technique (M)
 - one deposited metal test assembly from which one all weld metal longitudinal tensile test and three Charpy V-notch impact tests are to be taken.

c) T and M techniques (TM)

- the test assemblies and relevant tests required for T and M techniques are to be carried out. The longitudinal tensile test specified in a) for T technique is not required.

5.3.2 The weld and test procedures, the type of current, the materials, the test results and the re-test procedures, where applicable, are regulated by the requirements relative to the approval tests.

Where a wire flux combination is approved for welding both normal strength and higher strength steels, the steels of the highest strength approved are to be used for the preparation of the butt weld assembly required by the T technique, in order to also cover the lower strength levels.

6 Flux-wire combinations for one side submerged arc welding of butt-joints of C and C-Mn steels

6.1 Application

6.1.1 The requirements of this Article apply to flux-wire combinations for submerged-arc welding processes with high current, used for one side welding (U welding technique) of butt-joints with one or more layers (in general not more than two layers).

The welding machine may have one or more welding heads. A suitable backing support, for example a flux layer and support equipment, may be adopted.

The requirements of Article [5] are also to be complied with, as applicable, unless otherwise stated in this Article.

6.2 Approval tests

6.2.1 The edge preparation of the various samples and the welding parameters to be used are those proposed by the Manufacturer and they are to be reported in the approval certificate; they are to be appropriate to ensure complete fusion and satisfactory surface appearance.

The specimens which are required to be obtained from the samples are the same as indicated in [5.2.5] except for impact test specimens, which are to be taken as follows (see Fig 15):

- for samples of thickness $s = 12-15$ mm: three specimens at mid-thickness
- for samples of thickness $s = 20-25$ mm: six specimens, three near each surface
- for samples of thickness $s = 30-35$ mm: nine specimens, three near each surface and three at mid-thickness.

Figure 15 : Position of Charpy V-notch impact test for one side automatic welding

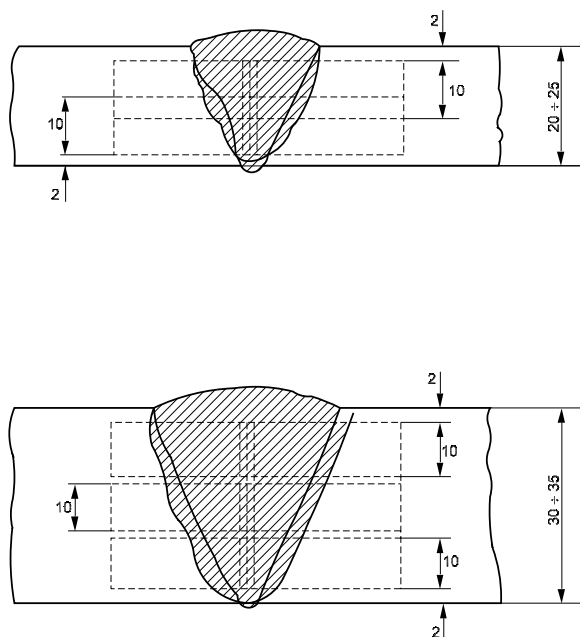

6.3 Annual control tests

6.3.1 The periodical control tests are to include at least one butt weld test assembly with plate thickness 20-25 mm from which one transverse tensile, two bend tests (one root and one face bend) and six impact tests are to be taken. One longitudinal tensile test is also to be prepared for wire flux combinations approved solely for the one side technique.

6.3.2 The weld and test procedures, the type of current, the materials, the test results and the re-test procedures, where applicable, are regulated by the requirements relative to the approval tests.

Where a wire flux combination is approved for welding both normal strength and higher strength steels, the steels of the highest strength approved are to be used for the preparation of the butt weld assembly, in order to also cover the lower strength levels.

7 Wires and wire-gas combination for semiautomatic welding of C and C-Mn steels

7.1 Application

7.1.1 The requirements of this Article apply to bare wire gas combinations and flux cored or flux coated wires with or without shielding gases, to be used for semiautomatic welding of hull structural steels, of the corresponding grades of steel forgings and castings and of comparable steels intended for other structural applications or pressure systems.

The term semiautomatic is used to describe processes in which the weld is made manually by a welder holding a gun through which the wire is continuously feed. For the

purpose of the approval designation, this technique is identified by the symbol S.

7.2 Type of wires

7.2.1 The chemical composition of bare wires normally used is shown in Tab 15.

Types G3Si1 and G4Si1 are particularly intended for welding processes under CO₂ shielding gas and the other types for welding processes where mixtures of shielding gases are used.

The Manufacturers are to submit to ^{Tasneef} for consideration, wires having chemical composition other than those given in Tab 15.

Table 14 : Composition of gas mixtures for continuous wire welding process

Group symbol	Composition of gas mixtures in volume (%)			
	Ar (1)	H ₂	CO ₂	O ₂
C 1			100	-
C2			70 - 99	1 - 30
M11	90 - 98	1 - 5	1 - 5	-
M12	95 - 99		1 - 5	-
M13	97 - 99	-	-	1 - 3
M14	92 - 98	-	1 - 5	1 - 3
M21	75 - 94	-	6 - 25	-
M22	90 - 96	-	-	4 - 10
M23	67 - 93	-	6 - 25	1 - 8
M31	50 - 74	-	26 - 50	-
M32	85 - 89	-	-	11 - 15
M33	35 - 85	-	6 - 50	9 - 15
(1) Argon may be replaced by Helium up to 95% of the argon content.				

7.3 Shielding gases

7.3.1 Where applicable, the composition of the welding gas is to be reported.

For the purpose of the approval, the type of gas and mixture of gas are grouped as indicated in Tab 14.

Unless otherwise required for specific applications, gas mixtures in the same group are considered equivalent for approval purposes.

7.4 Grading

7.4.1 Wire gas combinations are divided, for the various strength levels, into the following grades:

- 1, 2, 3, 4 for normal strength steels
- 1Y, 2Y, 3Y, 4Y, 5Y for high strength steels with specified minimum yield strength up to 355 N/mm²
- 2Y40, 3Y40, 4Y40, 5Y40 for high strength steels with specified minimum yield strength up to 390 N/mm².

Depending on the welding technique, the symbol S is added to indicate semiautomatic welding technique.

7.4.2 Flux cored or flux coated wires may be required to be submitted to the hydrogen test as detailed in [2.5], using the Manufacturer's recommended welding conditions and adjusting the deposition rate to give a weight of weld deposit per sample similar to that deposited when using manual electrodes.

On the basis of the test results, the welding consumables may be given one of the symbols H or H15, HH or H10, H5 as appropriate.

7.5 Information and documentation to be submitted

7.5.1 The following information and supporting documentation, as appropriate, are generally to be submitted together with the request for approval:

- commercial name, type of wire, limits of chemical composition in the case of bare wires and information on additives in the case of flux cored or coated wires and range of wire diameters to be approved; producer, supplier, conditions under which it is supplied (surface protection, diameters and weight of the standard coils)
- welding technique and grading under which the approval is requested; type of current, welding positions and range of current for which the approval is requested
- properties, composition and requirements relevant to the shielding gas or gas mixture; commercial brand and Manufacturer, in the case of gas mixtures of special types
- typical chemical composition of the deposited metal, with particular reference to the contents of Mn, Si and alloying elements, which are to be specified in all cases; conditions to which the chemical composition refers
- main operating characteristics and welding techniques (such as spray arc, short arc or dip transfer), associated recommendations and limitations
- packaging and labelling (marking)
- Manufacturer's workshop, manufacturing facilities, manufacturing and treatment cycles, methods and procedures of Manufacturer's quality controls
- recommendations for storing and preservation of flux cored and coated wires
- previous approvals granted to the proposed gas wire combination.

7.6 Approval tests

7.6.1 General

Deposited metal and butt weld tests are to be performed as indicated in [7.6.2] and [7.6.3], and summarised in Tab 16.

A few preliminary samples may be required by the Surveyor to be welded, in order to check the operating characteristics and set up the welding parameters. These tests may be limited to the fillet test assemblies required in [7.6.7].

7.6.2 Deposited metal test

Two deposited metal test assemblies are to be welded in the flat position as shown in Fig 4, one using a wire of 1,2mm or the smallest size to be approved and the other using a wire of 2,4mm or the largest size to be approved. If only one diameter is available, one test assembly is sufficient. Any grade of hull structural steel may be used for the preparation of the test assembly.

The preparation is to be in accordance with Fig 4; however, the angle of the bevel and the gap at the root may be modified depending on the welding process.

The weld metal is to be deposited in multi-run layers according to the normal practice (with wide beads extending for the full width of the bevel), as far as this is correctly feasible, regardless of the diameter of the wire; the direction

of deposition of each layer is in general to alternate from each end of the plate, each run of weld metal having thickness in the range 2 mm to 6 mm (compensation included). Between each run the assembly is to be left in still air until it has cooled to less than 250°C but not below 100°C, the temperature being taken in the centre of the weld on the surface of the seam. After being welded, the test assemblies are not to be subjected to any heat treatment except where approval has also been requested in the stress relieved condition. In such case the symbol D is to be added to the grade designation.

The specimens shown in Fig 4 are to be taken for the following tests:

- one longitudinal tensile test
- three Charpy V-notch impact tests.

Table 15 : Solid wire chemical composition

Type of wire	Chemical composition (%) (2)								
	C max	Mn	Si	P max	S max	Cr max	Ni max	Cu max (1)	Mo
G2Si	0,14	0,90 - 1,30	0,50 - 0,80	0,025	0,025	0,15	0,15	0,35	-
G3Si1	0,14	1,30 - 1,60	0,70 - 1,00						
G4Si1	0,14	1,60 - 1,90	0,80 - 1,20						
G4Mo	0,14	1,70 - 2,10	0,50 - 0,80						
G4Si	0,14	1,60 - 1,90	0,80 - 1,20						-

(1) Including surface lining
(2) Al, Ti, Zr may be added by the Manufacturer and the values are to be submitted to ^{Tasneef} for consideration at the time of the request for the approval; reference may be made to the limits of EN 440.

Table 16 : Test assemblies and mechanical tests required

Test assembly						Tests required (1)
Type	Welding position (2)	Wire diameter (mm)	Number of samples	Thickness (mm)	Dimensions	
Deposited metal	Flat	Max.	1 (3)	20	Fig 4	1 TL - 3KV
		1,2 or min.	1			
Butt weld	Flat	First run: 1,2 or min.	1 (4)	15 - 20	Fig 16	1TT - 1RB - 1FB - 3KV
	Vertical upward	Remaining run: max	1			1TT - 1RB - 1FB - 3SB - 3KV
	Vertical downward		1			1TT-1RB-1FB- 3SB-3KV
	Horizontal		1			1TT-1RB-1FB- 3SB-3KV
	Overhead		1			1TT-1RB-1FB- 3SB-3KV
Fillet	(5)	First side: min. diam	1	15 - 20	Fig 6 Fig 7 Fig 8	Macro-Fracture-Hardness
		Second side: max. diameter				

(1) Abbreviations: TL = longitudinal tensile test; TT = transverse tensile test; RB = root bend test; FB = face bend test; SB = side bend test; KV = Charpy V-notch impact test.
(2) When the approval is requested only for one or more specified welding positions, the butt test samples are to be welded in such positions.
(3) If only one diameter is to be approved, only one test assembly is required.
(4) When the approval is requested in flat position only, two test samples are to be welded - the first sample with the maximum wire diameter and the second with increasing diameter from the first to the last pass.
(5) Fillet weld samples are to be welded in the position required for approval.

The chemical analysis of the deposited weld metal in each test assembly is to be supplied by the Manufacturer and is to include the content of all significant alloying elements, if any.

In general the chemical composition (C, Mn, Si) is determined near the surface of the final pass and is to be reported for information.

Figure 16 : Butt weld test assembly

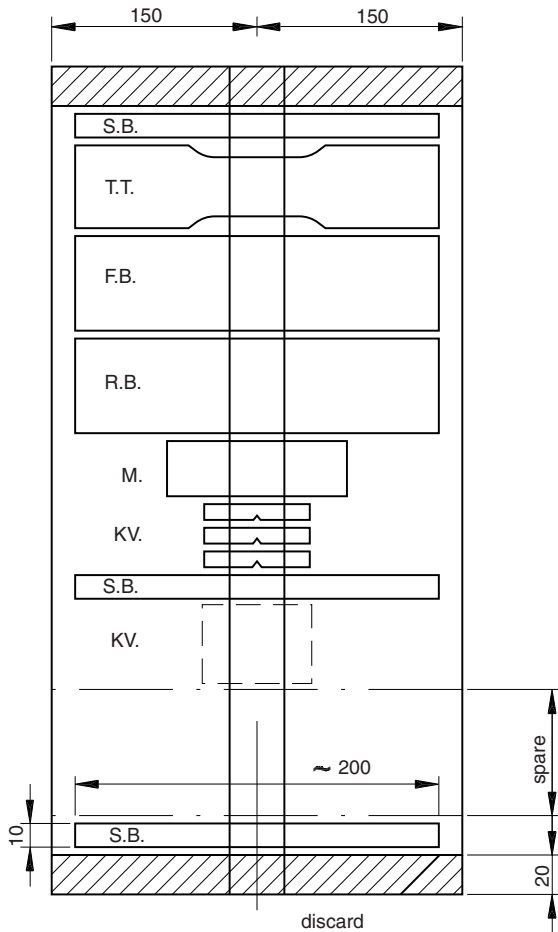

All the dimensions are in mm.

7.6.3 Butt weld tests

Butt weld test assemblies as shown in Fig 16 are to be welded for each welding position (flat, horizontal, vertical

upwards and downwards and overhead) for which the wire gas combination is to be approved.

One test sample is to be welded in downhand position using, for the first run, a wire of 1,2 mm or the smallest diameter to be approved and, for the remaining runs, wires of the maximum diameter to be approved.

Where wires are intended for flat position only, one additional test sample is to be welded, if possible using wires of different diameters from those required above.

The other test assemblies are to be welded in the vertical upwards, downwards, horizontal and overhead positions, using for the first run a wire of 1,2 mm or the smallest diameter to be approved, and for the remaining runs the largest diameter to be approved for the position concerned.

The grade of steel to be used for the preparation of the test assemblies is related to the grade of the electrodes as indicated in Tab 6.

For the electrodes to be approved under grades 4 and 5, in lieu of the hull steels specified in Tab 6, C-Mn steels for pressure vessels of grades L40 and L60, respectively, and strength appropriate to the electrode strength may be used.

The use of other types of steel is to be agreed with Tasneef on a case-by-case basis.

The welding is to be performed with the usual technique in compliance with requirements specified in [7.6.2] for the deposited metal test, as applicable. For all assemblies, the back sealing run is to be made with the same diameter of wire or with the largest diameter of wire used for the weld on the other side.

After being welded, the test assemblies are not to be subjected to any heat treatment except where approval has also been requested in the stress relieved condition. In such case the symbol D is to be added to the grade designation.

It is recommended and may be required that the welded assemblies should be subjected to a radiographic examination to ascertain if there are any defects in the weld prior to the preparation of test specimens.

The specimens shown in Fig 16 are to be taken for the following tests:

- a) one transverse tensile test
- b) three Charpy V-notch impact tests
- c) one face and one root bend tests.

Three additional side bend tests [1.5.4] may be required by the Surveyor to be carried out for samples welded in vertical, horizontal and overhead positions.

Table 17 : Mechanical properties

Grade	Longitudinal tensile test on deposited metal			Tensile test on butt weld	Charpy V-notch impact test Minimum average energy (J)		
	Yield stress R_{eH} (N/mm ²) min.	Tensile strength R_m (N/mm ²)	Elong A_5 (%) min.	Tensile strength R_m (N/mm ²) min.	Test temp. (C°)	Flat, Horizontal, Overhead	Vertical
1	305	400 - 560	22	400	+ 20	47	34
2					0		
3					- 20		
4					- 40		
1Y	375	490 - 660	22	490	+ 20	47	34
2Y					0		
3Y					- 20		
4Y					- 40		
5Y					- 60		
2Y40	400	510 - 690	22	510	0	47	39
3Y40					- 20		
4Y40					- 40		
5Y40					- 60		41

7.6.4 Test requirements

The required results of tensile and impact tests on deposited metal and butt weld tests are indicated in Tab 17.

Bend tests are to be performed on a mandrel having a diameter equal to three times the thickness of the specimen; the results are to comply with the requirements in [1.5.3].

7.6.5 Approval in the stress relieved condition

The requirements set forth in [2.4.5] apply.

7.6.6 Tests for checking the hydrogen content

When the additional symbols H10 (or HH) or H5 are required, the provisions under [2.5] apply.

7.6.7 Fillet weld test assemblies

Fillet weld test assemblies are generally required in addition to the butt weld test and are to be welded in each of the positions applied for approval (horizontal-vertical, vertical, overhead). The requirements set forth in [2.6] apply, as appropriate.

7.7 Annual control tests

7.7.1 The annual tests are to include at least the following assemblies and tests:

- One deposited metal test assembly is to be welded in accordance with [7.6.2] with wire having minimum or maximum diameter, and the required tests (one longitudinal tensile test and three Charpy V-notch impact tests) are to be conducted.
- At the discretion of ^{Tasneef} a butt weld test, to be welded in vertical position, may also be required and three side

bend tests and three Charpy V-notch impact tests are to be performed.

- For flux cored wire electrodes approved with symbol H10 (or HH) or H5, the hydrogen content may be required to be checked with the same procedure used in the approval tests.
- The chemical composition may be required to be checked under conditions corresponding to those of the approval tests.

The weld and test procedures, the type of current, the materials, the test results and the re-test procedures, where applicable, are regulated by the requirements relative to the approval tests.

8 Wires and wire-gas combinations for automatic welding of C and C-Mn steels

8.1 Application

8.1.1 General

The requirements of this Article apply to bare wire-gas combinations and flux cored or flux coated wires with or without shielding gases to be used for automatic welding processes with multi-run technique (M) and two-run technique (T).

As regards preliminary information and requirements not expressly stated in this Article, reference may be made as far as applicable to the corresponding requirements of Article [7].

8.2 Approval tests

8.2.1 General

Test samples for the approval are to be carried out using the welding technique for which approval is requested (multi-run M or two-run T technique).

In the case of the multi-run welding technique using wire diameters approved with the semiautomatic process, the tests are not to be repeated with the automatic process.

8.2.2 Multi-run technique

Where approval for use with the multi-run technique (M) is requested, deposited weld metal and butt weld tests are to be carried out as indicated in [8.2.3] and [8.2.4], respectively.

8.2.3 Deposited metal test

One deposited metal test is to be welded as shown in Fig 11; The base metal, the preparation of the test assembly welding, the checks and the number of tests required are to be as indicated in [5.2.3], except that the thickness of each layer is to be not less than 3 mm.

The wire diameter, type of current and welding parameters are to be in accordance with the recommendation of the Manufacturer.

The results of the tests are to comply with the requirements of Tab 18.

8.2.4 Butt weld tests for multi-run technique

One butt weld assembly is to be welded as shown in Fig 12 for each position to be approved; the base metal, the preparation of the test assembly welding, the checks and the

number of test specimens required are to be as indicated in [5.2.4].

The diameter of the wire, type of current and welding parameters are to be in accordance with the recommendation of the Manufacturer.

The results of the tests are to comply with the requirements of Tab 18.

8.2.5 Two-run technique

Where approval for use with the two-run technique only (T) is requested, two butt weld test assemblies are to be carried out and no deposited metal test is requested.

The indications in [5.2.5] generally apply if not modified below, except that one test assembly is to be 12-15 mm thick and the other is to be 20 mm thick.

The bevel preparation of the test assemblies is to be as shown in Fig 17. Small deviations in the edge preparation may be allowed according to the Manufacturer's recommendations.

If approval is requested for welding plates thicker than 20 mm, one assembly is to be prepared with plates 20 mm thick and the other with the maximum thickness for which the approval is requested. For assemblies using plates over 25 mm in thickness, the edge preparation used is to be reported for information.

The base metal, checks and number of test specimens required are to be as indicated in [5.2.5].

The diameter of the wire, type of current and welding parameters are to be in accordance with the recommendation of the Manufacturer.

The results of the tests are to comply with the requirements of Tab 18.

Table 18 : Mechanical properties

Grade	Longitudinal tensile test on deposited material			Tensile test on butt weld	Charpy V-notch impact test	
	Yield stress R_{eH} (N/mm ²) min.	Tensile strength R_m (N/mm ²)	Elong. A_5 (%) min.	Tensile strength R_m (N/mm ²) min.	Test temp. (°C)	Minimum average energy (J)
1	305	400 - 560	22	400	+ 20	34
2					0	
3					- 20	
2Y	375	490 - 660	22	490	0	34
3Y					- 20	
4Y					- 40	
5Y					- 60	
2Y40	400	510 - 690	22	510	0	39
3Y40					- 20	
4Y40					- 40	
5Y40					- 60	41

Figure 17 : Recommended edge preparation for two-run butt weld test assemblies

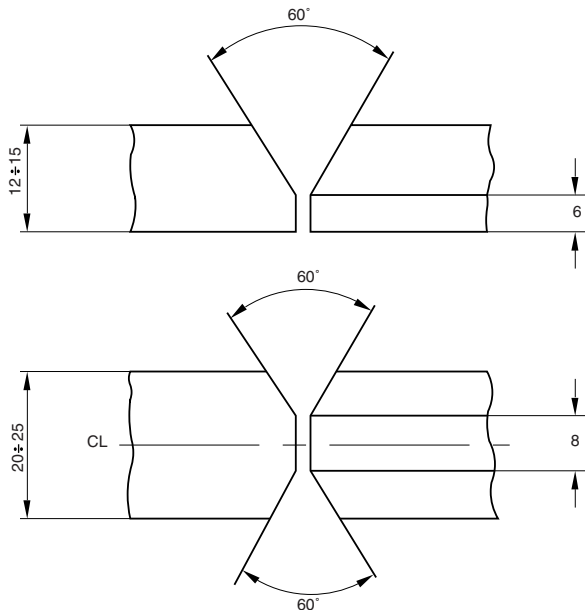

8.3 Annual control tests

8.3.1 Multi-run technique

The annual tests are to include at least the following:

- One deposited metal test assembly is to be welded in accordance with [8.2.3] with wires having minimum or maximum diameter, and the required tests (one longitudinal tensile test and three Charpy-V notch impact tests) are to be conducted.
- The chemical composition may be required to be checked under conditions corresponding to those of the approval tests.

8.3.2 Two-run technique

The annual tests are to include at least the following:

- One butt weld test assembly is to be welded in accordance with [8.2.5] with wires having minimum or maximum diameter, and the required tests (one longitudinal tensile test, three Charpy V-notch impact tests and two bend tests) are to be performed. One longitudinal tensile test is also required when the wire is approved for the two-run technique only.
- The chemical composition may be required to be checked under conditions corresponding to those of the approval tests.

8.3.3 Test requirements

The weld and test procedures, the type of current, the materials, the test results and the re-test procedures, where applicable, are regulated by the requirements relative to the approval tests.

For flux cored wire electrodes approved with symbol H10 (or HH) or H5, the hydrogen content may be required to be checked with the same procedure used in the approval tests.

9 Consumables for welding C and C-Mn steels with electrogas or electroslag process

9.1 Application

9.1.1 General

The requirements of this Article apply to wire gas combinations and flux cored or flux coated wires for electrogas (EG) and electroslag (ES) vertical welding with or without consumable nozzles of hull structural steels, of the corresponding grades of steel forgings and castings and of comparable steels intended for other structural applications.

9.1.2 Type of wires

The wires are to be of the type recommended by the Manufacturer, obtained from original packages and of known chemical composition.

For electrogas processes, wires having the chemical composition specified in Tab 15 may be used. Other wires of different chemical composition are to be submitted for consideration.

9.1.3 Shielding gases

The requirements specified in [7.3.1] apply.

9.1.4 Grading

The consumables are divided, for the various strength levels, into the following grades:

- 1, 2, 3 for normal strength steels
- 2Y, 3Y, 4Y for high strength steels with specified minimum yield strength up to 355N/mm²
- 2Y40, 3Y40, 4Y40 for high strength steels with specified minimum yield strength up to 390N/mm².

For high strength steels, the approval may be restricted for use with steels of specific composition. This applies, in particular, in relation to the content of grain refining elements, and if general approval is required, a Niobium treated steel is to be used for approval tests.

9.2 Information and documentation to be submitted

9.2.1 Information and documentation to be submitted

The following information and supporting documentation are to be submitted together with the request for approval:

- commercial name, type of wire, limits of chemical composition in the case of bare wires and information on additives in the case of flux cored or coated wires and range of wire diameters to be approved; producer, supplier, conditions under which it is supplied (surface protection, diameters and weight of the standard coils)
- welding technique and grading under which the approval is requested
- properties, composition and requirements relevant to the shielding gas or gas mixture; commercial brand and Manufacturer, in the case of gas mixtures of special types

- d) type of flux, consumable insert when used
- e) type of current, range of current for which the approval is requested
- f) main characteristics of the welding equipment
- g) typical chemical composition of the deposited metal
- h) main operating characteristics and welding techniques, associated recommendations and limitations in general and in particular as regards edge preparation and welding parameters
- i) Manufacturer's workshop, manufacturing facilities, manufacturing and treatment cycles, methods and procedures of Manufacturer's quality controls
- j) packaging and marking
- k) recommendations for storing and preservation of wires and fluxes
- l) previous approvals already granted to the proposed consumables.

9.3 Approval tests

9.3.1 Two butt weld test assemblies are to be prepared: one with plates 20/25 mm thick, the other with plates 35/40 mm thick or more.

The grade of steel to be used for each of these assemblies is to be selected according to the requirements given in Tab 12 for two-run submerged arc welding.

The chemical composition of the plate, including the content of grain refining elements, is to be reported.

The welding conditions and the edge preparation adopted are to be in accordance with the recommendation of the Manufacturer and are to be reported.

The Manufacturer's maximum recommended gap between plates is to be used in making the test assemblies.

The test assemblies are to be submitted to radiographic and or ultrasonic examination to ascertain the absence of defects prior to the preparation of test specimens.

Figure 18 : Butt weld test assembly for electro-gas and electro-slag welding

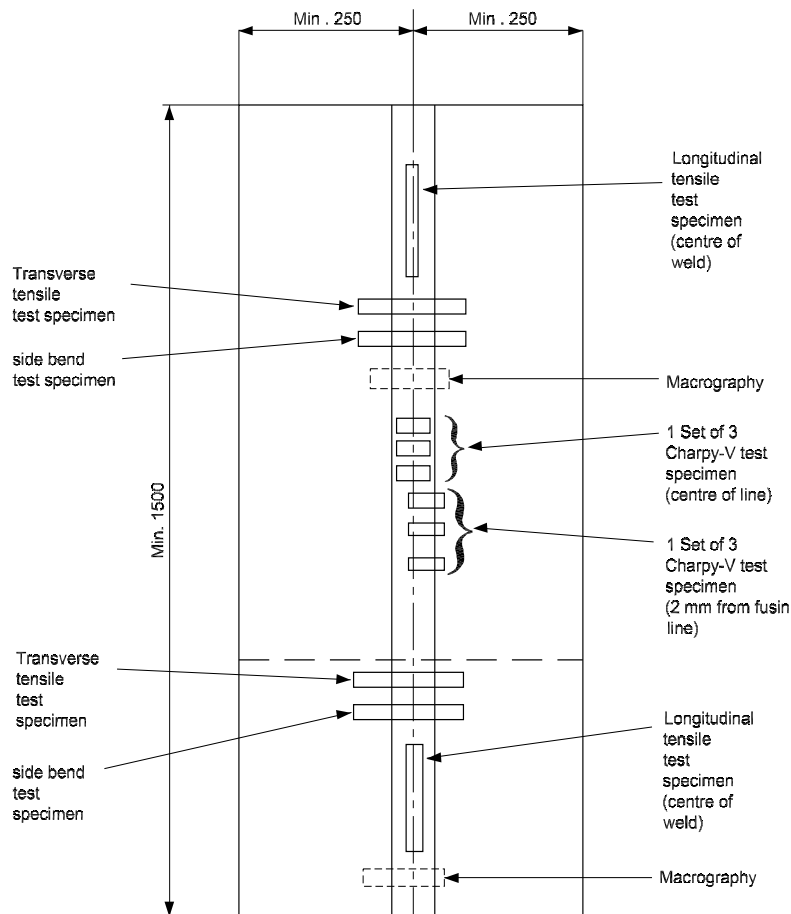
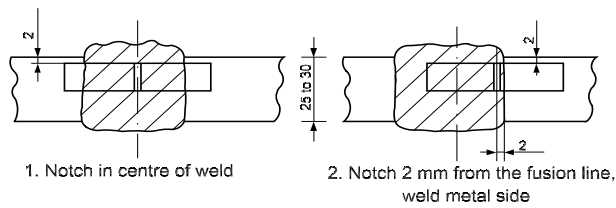

Figure 19 : Position of Charpy V-notch impact test specimens



All the dimensions are in mm.

The specimens shown in Fig 18 are to be taken for the following tests:

- two longitudinal tensile tests
- two transverse tensile tests
- two side bend tests
- two sets of three Charpy V-notch impact tests with notch located as shown in Fig 19 (i.e. one set with the notch located in the centre of the weld and one set with the notch located at 2 mm from the fusion line in the weld metal)
- two macro sections (in the middle of the sample and towards the end) and, if required, Vickers hardness checks.

The chemical analysis of the deposited weld metal is to be supplied by the Manufacturer and is to include the content of all significant alloying elements, if any.

9.3.2 The results of tensile and impact tests on deposited metal and butt weld tests are to comply with the requirements specified in Tab 18 , as appropriate.

Side bend tests [1.5.4] are to be performed on a mandrel having a diameter equal to three times the thickness of the specimen; the results are to comply with requirements in [1.5.3].

The Vickers hardness values, when verification is required, are to be $HV \leq 270$.

9.4 Annual control tests

9.4.1 The annual tests are to include at least a butt weld test assembly having thickness 20/25 mm. The non-destructive examinations required for the approval are to be carried out on this sample and the following test specimens are to be taken:

- one longitudinal tensile test specimen
- one transverse tensile test specimen
- two side bend test specimens
- one set of three Charpy V-notch impact tests with the notch in the weld at 2 mm from the fusion line
- one set of three Charpy V-notch impact tests with the notch in the centre of the weld
- one section for macrographic examination.

The chemical composition may be required to be checked under conditions corresponding to those of the approval tests.

The weld and test procedures, the type of current, the materials, the test results and the re-test procedures, where applicable, are regulated by the requirements relative to the approval tests.

10 Consumables for welding high strength quenched and tempered steels

10.1 Application

10.1.1 General

The requirements of this Article apply to consumables used for weldable high strength quenched and tempered steels with minimum specified yield strength from 420 N/mm² to 690 N/mm².

Unless otherwise stated in this Article, the requirements relevant to the procedure, tests samples and welding conditions are generally to be in accordance with those of the previous Articles relevant to the approval of consumables for welding carbon and carbon-manganese steels, as follows:

- Article [2]: Covered electrodes for manual metal arc welding
- Article [5]: Flux-wire combination for submerged arc welding
- Article [7]: Wires and wire-gas combination for semi-automatic welding processes employing continuous wire
- Article [8]: Wires and wire-gas combination for automatic welding processes employing continuous wire.

10.1.2 Grading

For every resistance level of the "Q&T" steels, the welding consumables are divided into the following grades: 3Y, 4Y, 5Y.

The symbol Y is followed by a number related to the minimum specified yield strength of the weld metal (e.g. 42 for 420 N/mm²).

10.2 Approval tests

10.2.1 The same samples are required as for C and C-Mn steel welding consumables approval .

The deposited metal and the butt weld test samples are to be prepared using high strength steel having mechanical properties corresponding, as appropriate, to those of the welding consumable to be approved.

However, at the request of the Manufacturer, the all deposited metal samples may be allowed to be prepared using any C or C-Mn steels, provided that the bevels are duly butted with the welding consumable to be approved.

10.2.2 The checking of the chemical composition is to be carried out on shavings taken from the deposited material samples.

The checking of C, Mn, Si, S, P, Cr, Cu, Ni, Mo, N and of other alloying elements stated by the Manufacturer is to be carried out on all the samples.

10.2.3 Welding consumables other than solid wire-gas combinations are to be subjected to a hydrogen test in accordance with [2.5] or recognised standards, as applicable.

The above consumables are to satisfy the hydrogen test requirement at least for the symbol H10 or H5 for steels having specified yield strength levels, respectively, not higher or higher than 500 N/mm².

10.2.4 Unless special requests are made by the Manufacturer, the samples are not to be post-weld heat treated.

10.3 Test requirements

10.3.1 In the tests for checking the operating conditions, the requirements specified under Articles [2], [5] and [7] for electrodes, submerged arc fluxes and wires for continuous wire processes, respectively, are to be met.

In the tests for checking the chemical composition, the limits in percentage specified and guaranteed by the Manufacturer are to be satisfied.

In the tests for checking the mechanical properties, the requirements specified in Tab 19 are to be met.

The results of the bend tests are to comply with the requirements in [1.5.3].

Where the required bending angle is not achieved, the specimen may be considered as fulfilling the requirements if the bending elongation L₀ on a gauge length equal to L₅+t (L₀ being the width of the weld and t the specimen thickness) fulfils the minimum elongation requirements specified for the deposited metal tensile test.

10.4 Annual control tests

10.4.1 For the periodical control tests, the samples and tests for checking the mechanical properties are to be carried out as required for C and C-Mn steel welding consumables.

Table 19 : Mechanical properties

Grade		Tensile test on deposited metal			Tensile test on butt weld	Charpy V-notch impact test		Bend ratio and angle
		Yield stress R _{eH} (N/mm ²) min.	Tensile strength R _m (N/mm ²)	Elong. A ₅ (%) min.	Tensile strength R _m (N/mm ²) min.	Test temp. (°C)	Minimum average energy (J)	D/t (1) α ≥ 120°
3	Y42	420	530 - 680	20	530	- 20	47	4
4						- 40		
5						- 60		
3	Y46	460	570 - 720	20	570	- 20	47	4
4						- 40		
5						- 60		
3	Y50	500	610 - 770	18	610	- 20	50	5
4						- 40		
5						- 60		
3	Y55	550	670 - 830	18	670	- 20	55	5
4						- 40		
5						- 60		
3	Y62	620	720 - 890	18	720	- 20	62	5
4						- 40		
5						- 60		
3	Y69	690	770 - 940	17	770	- 20	69	5
4						- 40		
5						- 60		

The tensile strength of the weld metal may be up to 10% below the requirements, provided the results obtained with the transverse tensile tests on the butt weld are satisfactory.

(1) D = mandrel diameter, t = specimen thickness

11 Consumables for welding Mo and Cr-Mo steels

11.1 Application

11.1.1 General

The requirements of this Article apply to consumables used for welding Mo and Cr-Mo steels.

Unless otherwise stated in this Article, the requirements relevant to the procedure, tests samples and welding conditions are generally to be in accordance with those of the previous Articles relevant to the approval of consumables for welding carbon and carbon-manganese steels, as follows:

- Article [2]: Covered electrodes for manual metal arc welding
- Article [5]: Flux-wire combination for submerged arc welding
- Article [7]: Wires and wire-gas combination for semiautomatic welding processes employing continuous wire
- Article [8]: Wires and wire-gas combination for automatic welding processes employing continuous wire.

11.1.2 Grading

Consumables are divided into the following grades, designated by a symbol indicating the nominal percentage Mo and Cr content of the deposited weld metal, as follows:

- M for Mo = 0,5
- C1M for Cr = 1,25 and Mo = 0,5
- C2M1 for Cr = 2,25 and Mo = 1

11.2 Approval tests

11.2.1 The same samples as for the C and C-Mn steel welding consumables approval are required.

The butt weld test samples are to be prepared using the corresponding grade of Mo or Cr-Mo steels.

Instead of the above-mentioned Mo and Cr-Mo steels, at the request of the Manufacturer, grades 460 and 510 C-Mn steels for boilers and pressure vessels may be used.

11.2.2 When the approval is required for two types of the same consumable, one with normal C content and the other with "low C" content, i.e. with C content not higher than 0,05%, and if the Manufacturer certifies that the only difference is the C content, for the approval of "low C" welding consumables the tests for checking the mechanical properties of the deposited material and the chemical composition only are to be carried out.

11.2.3 With the exception of those for the hydrogen content checking, the test samples are to be welded in the preheating condition and are to be post-weld heat treated, as

indicated in Tab 20, depending on the grade of the consumable.

Table 20 : Pre- and post-weld heating

Consumable grade	M	C1M	C2M1
Preheating:			
Temperature (°C)	-	100 - 150	200 - 280
Post-weld heat treatment:			
Temperature T (°C)	620 ± 10	660 ± 10	710 ± 10
Soaking time at T (minutes)	30	30	60
Cooling rate down to 500°C (°C/h) in furnace (1)	150 - 250	150 - 250	100 - 200
(1) When 500°C is reached, the cooling may be continued either in the furnace or in still air.			

11.2.4 In the case of covered electrodes for manual welding, the checking of the chemical composition is to be carried out, as a rule, on samples of deposited metal described in [1.6].

Two samples are required with two different electrode diameters.

In the case of other types of welding consumables, the checking is to be carried out on shavings taken from the deposited metal samples.

The checking of C, Cr and Mo contents is to be carried out on all the samples and, additionally, the checking of Mn, Si, Cu, Ni, S and P contents and that of other alloy elements is to be carried out on one sample.

11.2.5 Consumables may be submitted, at the Manufacturer's request, to hydrogen tests and have the additional symbol H10 (or HH) or H5 added to the grade designation according to the hydrogen content.

11.3 Test requirements

11.3.1 In the tests for checking the operating characteristics, the requirements specified in Articles [2] [5], [7] and [8] for electrodes, submerged arc fluxes and wires for continuous wire processes, respectively, are to be met.

In the tests for checking the mechanical properties, the requirements specified in Tab 21 are to be met.

As a rule, transverse tensile tests on the welded joint are not required.

11.3.2 In the tests for checking the chemical composition, the limits in percentage of chemical composition specified in Tab 22 are to be met.

Table 21 : Mechanical properties

Grade	Tensile test on deposited metal (1)		Bend ratio and angle (2)
	Tensile strength R_m (N/mm ²)	Elong. A_5 (%) min.	D/t $\alpha \geq 120^\circ$
M	490 - 640	20	3
C1M	490 - 690	20	3
C2M1	540 - 785	18	4
(1) The values of the minimum yield strength R_{eH} and reduction of area are also to be recorded, for information purposes.			
(2) D = mandrel diameter, t = specimen thickness.			

11.4 Periodical control tests

11.4.1 For the periodical control tests, to be carried out as a rule every year, in addition to the samples and tests for checking the mechanical properties, as required for the consumables for welding C and C-Mn steels, the samples for checking the chemical composition, requested for the approval, are to be effected.

11.4.2 For the "low C" welding consumables described in [11.2.2], the control tests are limited to one sample of deposited metal [1.6] and to the checking of the chemical composition.

12 Consumables for welding Ni steels for low temperature applications

12.1 Application

12.1.1 General

The requirements of this Article apply to consumables used for welding Ni steels for low temperature applications.

Unless otherwise stated in this Article, the requirements relevant to the procedure, tests samples and welding conditions are generally to be in accordance with those in the previous Articles relevant to the approval of consumables

for welding carbon and carbon-manganese steels, as follows:

- Article [2]: Covered electrodes for manual metal arc welding
- Article [5]: Flux-wire combination for submerged arc welding
- Article [7]: Wires and wire-gas combination for semi-automatic welding processes employing continuous wire
- Article [8]: Wires and wire-gas combination for automatic welding processes employing continuous wire.

12.1.2 Grading

Consumables are divided into the following grades designated by a symbol indicating the type of nickel steel for which the consumables are intended, as follows:

- N15 for steels with Ni = 1,30 - 1,70 (%)
- N35 for steels with Ni = 3,25 - 3,75 (%)
- N50 for steels with Ni = 4,75 - 5,25 (%)
- N90 for steels with Ni = 8,50 - 10 (%)

12.2 Approval tests

12.2.1 The same samples as for the C and C-Mn steel welding consumables approval are required.

The butt weld test samples are to be prepared using the corresponding grade of Ni steel.

Instead of the above-mentioned Ni steel, at the request of the Manufacturer, steels with lower Ni content but having suitable mechanical properties for the tests to be carried out may be used. In such case, if deemed necessary by the Manufacturer, the bevels may be duly buttered with the welding consumable to be approved.

In the case of use of plates with buttered bevels and where the mechanical properties of the welding consumable are significantly lower than those of the base material, longitudinal instead of transverse specimens may be allowed to be taken for face and root bend tests. In this case the length of the sample is to be such as to allow the taking of these specimens.

Table 22 : Chemical composition

Grade	Chemical composition (%)								
	C	Cr	Mo	Mn	Si max.	S max.	P max.	Cu max.	Ni max.
M	0,12 (1)	0,15	0,40 - 0,65	0,50 - 0,90 (2)	0,60 (2)	0,040	0,040	0,20	0,30
C1M	0,12 (1)	1,0 - 1,5	0,40 - 0,65						
C2M1	0,10 (1)	2,0 - 2,5	0,90 - 1,20						
(1) In the case of electrodes to be certified as "low carbon " the carbon content is not to exceed 0,05%.									
(2) The actual values of Mn and Si contents, guaranteed by the Manufacturer, within the limits specified in the table, are to be stated at the time of the approval of single electrodes.									

12.2.2 In the case of covered electrodes for manual welding, the checking of the chemical composition is to be carried out, as a rule, on samples of deposited metal described in [1.6].

Two samples are required with two different electrode diameters.

In the case of other types of welding consumables, the checking is to be carried out on shavings taken from the deposited metal samples.

The checking of C, Ni, Mn and Si contents is to be carried out on all the samples and, additionally, the checking of Cu, Cr, S, P and other alloy elements is to be carried out on one sample.

12.2.3 Consumables may be submitted, at the Manufacturer's request, to hydrogen tests and have the additional symbol H10 (or HH) or H5 added to the grade designation according to the hydrogen content.

12.2.4 Unless special requests are made by the Manufacturer, the samples are not to be post-weld heat treated.

12.3 Tests requirements

12.3.1 In the tests for checking the operating characteristics, the requirements specified in Articles [2], [5], [7], [8] for electrodes, submerged arc fluxes and wires for continuous wire processes, respectively, are to be met.

In the tests for checking the mechanical properties, the requirements specified in Tab 23 are to be met.

As a rule, transverse tensile tests on the welded joint are not required.

12.3.2 In the tests for checking the chemical composition, the limits in percentage of chemical composition specified and guaranteed by the Manufacturer are to be met.

12.4 Annual control tests

12.4.1 For the periodical control tests, in addition to the samples and tests for checking the mechanical properties as required for the consumables for welding C and C-Mn

steels, the samples for checking the chemical composition, requested for the approval, are to be effected.

13 Consumables for welding Cr-Ni austenitic and austenitic-ferritic stainless steels

13.1 Application

13.1.1 General

The requirements of this Article apply to consumables used for welding Cr-Ni austenitic and austenitic-ferritic stainless steels.

Unless otherwise stated in this Article, the requirements relevant to the procedure, tests samples and welding conditions are, in general, to be in accordance with those in the previous Articles relevant to the approval of consumables for welding carbon and carbon-manganese steels, as follows:

- Article [2]: Covered electrodes for manual metal arc welding
- Article [5]: Flux-wire combination for submerged arc welding
- Article [7]: Wires and wire-gas combination for semiautomatic welding processes employing continuous wire
- Article [8]: Wires and wire-gas combination for automatic welding processes employing continuous wire.

13.1.2 Grading

Consumables intended for welding austenitic steels are divided into the following grades designated by a symbol corresponding to the AWS designation of the weld metal, as follows: 308, 308L, 316, 316L, 316LN, 317, 317L, 309, 309L, 309Mo, 310, 310Mo, 347.

The additional symbol BT is added when the requirements on impact test energy are satisfied at the temperature of -196°C.

Consumables intended for welding austenitic-ferritic steels are designated by a symbol indicating the nominal percentage content of Cr and Ni in the deposited metal (e.g. 2205 means 22% Cr and 5% Ni).

Table 23 : Mechanical properties

Grade	Tensile test on deposited metal			Tensile test on butt weld	Charpy V-notch impact test		Bend ratio and angle
	Yield stress R_{eH} (N/mm ²) min.	Tensile strength R_m (N/mm ²) min.	Elong. A_5 (%) min.	Tensile strength R_m (N/mm ²) min.	Test temp. (°C)	Minimum average energy (J)	D/t (1) $\alpha \geq 120^\circ$
N 15	355	470	22	490	- 80	34	3
N 35	355	470	22	490	- 100	34	3
N 50	380	520	22	540	- 120	34	4
N 90	480	670	22	690	- 196	34	4

(1) D = mandrel diameter, t = specimen thickness

13.2 Approval tests

13.2.1 The same samples as for the C and C-Mn steel welding consumables approval are required, with the exception of samples for hydrogen content checking.

The all deposited metal and the butt weld test samples are to be prepared using the corresponding grade of stainless steel.

However, at the request of the Manufacturer, the all deposited metal may be allowed to be prepared using C and C-Mn steels, provided that the bevels are duly buttered with the welding consumable to be approved.

13.2.2 When the approval is required for two types of the same welding consumable, one with normal C content and one with "low C" content, for the approval of "low C" welding consumables the tests for checking the mechanical properties of the deposited material and the chemical composition only are to be carried out.

13.2.3 In the case of covered electrodes for manual welding, the checking of the chemical composition is to be carried out, as a rule, on samples of deposited metal and described in [1.6].

One sample is required for each electrode diameter to be approved.

In the case of other types of welding consumables, the checking is to be carried out on shavings taken from the deposited metal samples.

The checking of C, Cr, Ni contents is to be carried out on all the samples, in addition to Mo, Nb and N contents where such elements characterise the welding consumable being tested. For only one of the diameters tested, the chemical analysis of the remaining elements listed in Tab 25 is also to be carried out.

13.2.4 For consumables for welding austenitic-ferritic steels, the ratio ferrite/austenite is also to be determined in the all deposited material.

13.2.5 Corrosion tests according to ASTM A262 Practice E, ASTM G48 Method A or equivalent recognised standards may be required, on a case-by-case basis, for austenitic and duplex stainless steel consumables.

13.2.6 Unless special requests are made by the Manufacturer, the samples are not to be post-weld heat treated.

Table 24 : Required mechanical properties

Grade	Tensile test on deposited metal			Tensile test on butt weld	Charpy V-notch impact test		Bend ratio and angle
	Yield stress $R_{p0.2}$ (N/mm ²) min.	Tensile strength R_m (N/mm ²) min.	Elong. A_5 (%) min.	Tensile strength R_m (N/mm ²) min.	Test temp. (°C)	Minimum average energy (J)	D/t (1) $\alpha \geq 120^\circ$
Austenitic							
308	290	540	25	515	-20 (2)	27	3
308L	275	490	25	485			
316	290	540	25	515			
316L	275	490	25	485			
316LN	290	540	25	515			
317	290	540	25	515			
317L	275	490	25	515			
309	290	540	22	515			
309L	275	490	22	515			
309Mo	290	540	22	515			
310	290	540	25	515			
310Mo	290	540	25	515			
347	290	540	25	515			
Austenitic-ferritic							
-	480	680	25	680	-20	27	3
(1) D = mandrel diameter, t = specimen thickness							
(2) The impact test temperature is -20°C, except when the additional symbol BT is required, in which case the test is to be carried out at -196°C.							

Table 25 : Chemical composition

Grade	Chemical composition (%)					
	C	Mn	Cr	Ni	Mo	Others
308	≤ 0,08	0,5 - 2,5	18 - 21	8 - 11	≤ 0,75	
308L	≤ 0,04	0,5 - 2,5	18 - 21	8 - 11	≤ 0,75	
316	≤ 0,08	0,5 - 2,5	17 - 20	11 - 14	2 - 3	
316L	≤ 0,04	0,5 - 2,5	17 - 20	11 - 14	2 - 3	
316LN	≤ 0,04	0,5 - 2,5	17 - 20	10 - 14	2 - 3	0,15 ≤ N ≤ 0,20
317	≤ 0,08	0,5 - 2,5	17 - 21	11 - 14	2,5 - 4	
317L	≤ 0,04	0,5 - 2,5	17 - 21	11 - 14	2,5 - 4	
309	≤ 0,15	0,5 - 2,5	22 - 26	11 - 15	≤ 0,75	
309L	≤ 0,04	0,5 - 2,5	22 - 26	11 - 15	≤ 0,75	
309Mo	≤ 0,12	0,5 - 2,5	22 - 26	11 - 15	2 - 3	
310	0,08 - 0,20	1,0 - 2,5	25 - 28	20 - 22,5	≤ 0,75	
310Mo	≤ 0,12	1,0 - 2,5	25 - 28	20 - 22	2 - 3	
347	≤ 0,08	0,5 - 2,5	18 - 21	9 - 11	≤ 0,75	8xC ≤ Nb+Ta ≤ 1

13.3 Test requirements

13.3.1 In the tests for checking the operating characteristics, the requirements specified in Articles [2], [5], [7], [8] for electrodes, submerged arc fluxes and wires for continuous wire processes, respectively, are to be met.

In the tests for checking the mechanical properties, the requirements specified in Tab 24 are to be met.

For consumables intended for welding Cr-Ni austenitic steels for which the approval is required with the additional symbol BT, the requirements on adsorbed energy in the impact test specified in the table are to be satisfied at the temperature of -196°C.

13.3.2 In the tests for checking the chemical composition of welding consumables intended for Cr-Ni austenitic steels, the limits in percentage specified in Tab 25 are to be satisfied.

In the tests for checking the chemical composition of welding consumables intended for austenitic-ferritic steels, the limits in percentage specified and guaranteed by the Manufacturer are to be satisfied.

13.4 Annual control tests

13.4.1 For the periodical control tests, in addition to the samples and tests for checking the mechanical properties as required for the consumables for welding C and C-Mn steels, the samples for checking the chemical composition are also to be effected.

13.4.2 For the "low C" welding consumables described in [13.2.2], the control tests are limited to one sample of deposited metal and to the checking of the chemical composition.

14 Consumables for welding aluminium alloys

14.1 Application

14.1.1 General

The requirements of this Article apply to wire or rod-gas combinations to be used for welding the Al-Mg and Al-Si aluminium alloys specified in Ch 3, Sec 2.

(Unless otherwise stated in this Article, the requirements relevant to the procedure, tests samples and welding conditions are generally to be in accordance with those in Articles [7] and [8] relevant to the approval of consumables for welding with continuous wire process).

The welding consumables preferably to be used for the aluminium alloys concerned are divided into two categories, as follows:

- W = wire electrode and wire gas combination for metal-arc inert gas welding (MIG), tungsten inert gas welding (TIG) or plasma arc welding (PAW)
- R = rod-gas combinations for tungsten inert gas welding (TIG) or plasma arc welding (PAW).

Note 1: For aluminium welding consumables, there is no unique relationship between the products (wire electrode, wire or rod) and the welding process used (TIG, MIG, PAW). Therefore the wire electrodes, wire or rods, in combination with the relevant shielding gas, will be approved on the basis of the above products form W and R and may be used, as appropriate, for one or more of the above processes.

14.1.2 Grading

The consumables are graded as specified in Tab 26 in accordance with the alloy type and strength level of the base materials used for the approval tests.

Table 26 : Consumable grades and base materials for the approval tests

Grade	Base material for the tests and alloy designation	
	Numerical	Chemical symbol
RA/ WA	5754	AlMg3
RB/ WB	5086	AlMg4
RC/ WC	5083	AlMg4,5Mn0,7
	5383	AlMg4,5Mn0,9
	5456	AlMg5
	5059	-
RD/ WD	6082	AlSiMgMn
	6005A	AlSiMg(A)
	6061	AlMg1SiCu

Note 1: Approval on higher strength AlMg base materials also covers the lower strength AlMg grades and their combination with AlSi grades.

14.1.3 Shielding gases

For the purpose of the approval, the type of gas and mixture of gas are grouped as indicated in Tab 27.

Unless otherwise required for specific applications, gas mixtures in the same group are considered equivalent for approval purposes.

Special gases in terms of composition or purity are to be designated with the group "S".

14.2 Approval tests

14.2.1 Deposited weld metal

For the testing of the chemical composition of the deposited weld metal, a test piece according to Fig 20 is to be prepared. The size depends on the type of the welding consumable (and on the process used) and is to give a sufficient amount of pure metal for chemical analysis. The base metal is to be compatible with the weld metal in respect of chemical composition.

The checking of chemical composition may also be carried out on shavings taken from samples of test assembly in Fig 20.

The results of the analysis are not to exceed the limit values specified by the Manufacturer.

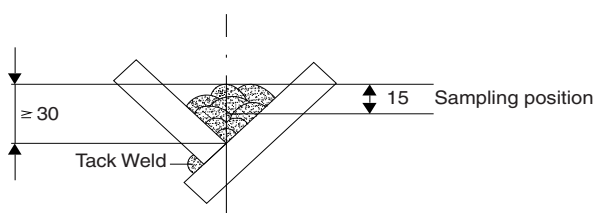
Figure 20 : Deposited weld metal test assembly

14.2.2 Butt weld test assembly

Butt weld test assemblies, in the material specified in Tab 26 and having thickness 10-12 mm, are to be prepared for each welding position (downhand, horizontal, vertical-upward and overhead) for which the consumable is recommended by the Manufacturer (see Fig 21); see also [14.2.3]. Subject to the agreement of Tasneef consumables satisfying the requirements for the downhand and vertical-upward position will also be considered as complying with the requirements for the horizontal position.

14.2.3 Additional butt weld test assembly

One additional test assembly, having 20-25 mm, is to be welded in the downhand position (see Fig 22).

14.2.4 Post-weld condition

On completion of welding, the assemblies are to be allowed to cool naturally to ambient temperature. Welded test assemblies and test specimens are not to be subjected to any heat treatment. Grade D assemblies are to be allowed to naturally ageing for a minimum period of 72 hours from the completion of the welding and a maximum of one week, before testing is carried out.

Table 27 : Composition of shielding gases

Group symbol	Gas composition in volume (%) (1)	
	Argon	Helium
I-1	100	-
I-2	-	100
I-3 (2)	Balance	> 0 to 33
I-3 (2)	Balance	> 33 to 66
I-3 (2)	Balance	> 66 to 95
S	Special gas composition to be specified	

(1) Gases of other chemical composition (mixed gases) may be considered as special gases and are to be covered by separate tests

(2) Gas mixture to be used for the tests is as follows:

- Group I-3(1): approx. 15% He
- Group I-3(2): approx. 50% He
- Group I-3(3): approx. 75% He

14.3 Test requirements

14.3.1 It is recommended that the weld assemblies are subjected to radiographic examination to ascertain if there are any defects in the welds prior to the preparation of the test specimens.

In the tests for checking the operating characteristics, the requirements specified in Article [7] for wires for continuous wire processes are to be met.

The macro specimen is to be examined for defects such as cracks, lack of fusion, cavities, inclusions and pores. Cracks, lack of fusion or incomplete penetration are not allowed.

In the tests for checking the mechanical properties, the requirements specified in Tab 28 are to be met.

It is recommended that the bending test is performed with the “wrap around bending method” instead of the “free” bend test (see Fig 23).

14.4 Annual control tests

14.4.1 For the periodical control tests, the butt weld test assembly in Fig 21 is to be carried out in downhand position using the wire having the maximum approved diameter. Moreover the deposited weld metal test assembly (see Fig 20) is to be carried out.

Figure 21 : Butt weld test assembly for positional welding

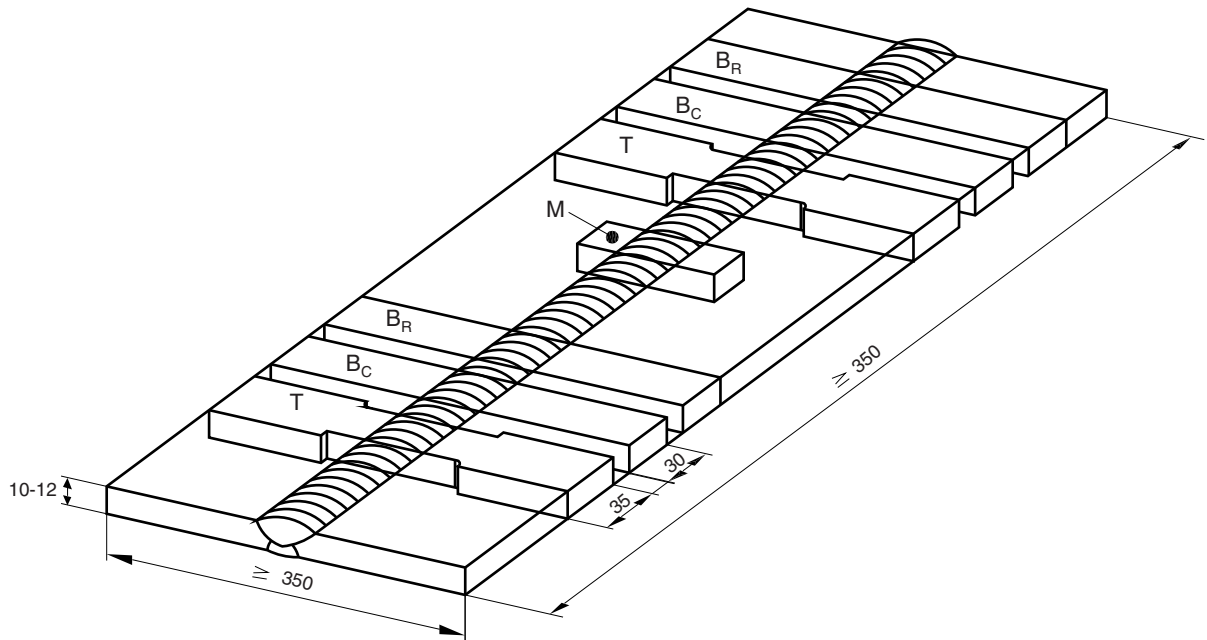

T = flat tensile test specimen; B_c = face bend test specimen; B_r = root bend test specimen; M = macrographic section

Figure 22 : Additional butt weld test assembly in downhand position

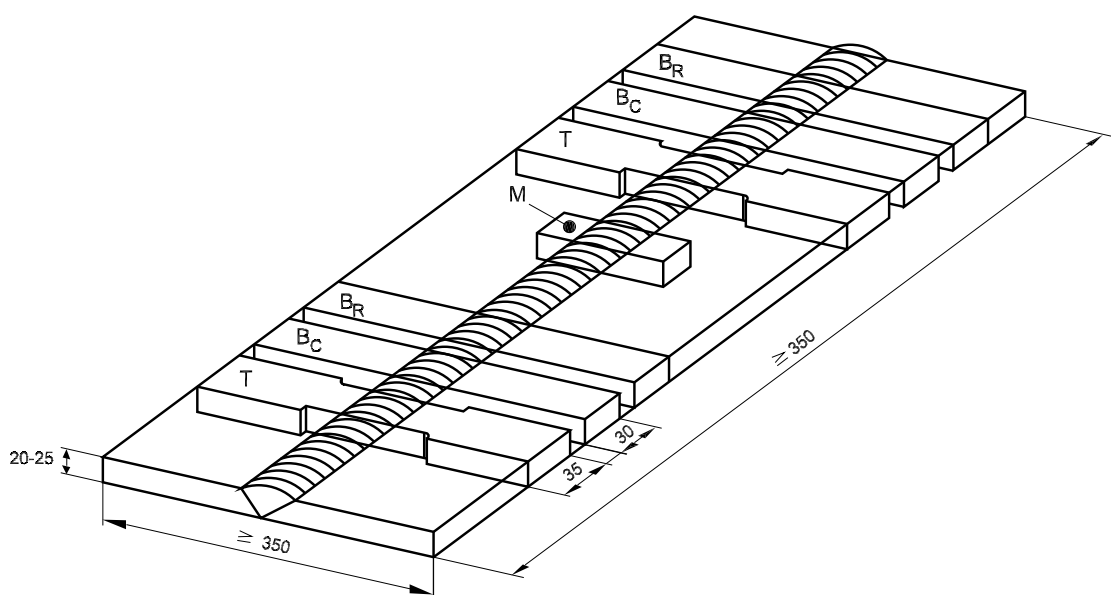

T = flat tensile test specimen; B_c = face bend test specimen; B_r = root bend test specimen; M = macrographic section

Figure 23 : Wrap around bend test

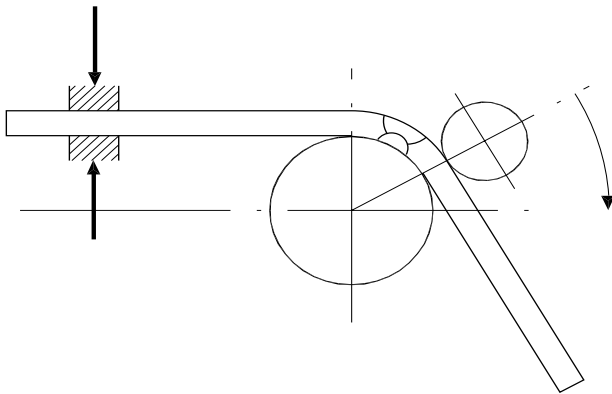

The fixed edge of the test specimen is to be clamped to avoid sliding. The whole welded zone (weld and heat affected zone), in the case of transverse bending, is to be entirely positioned in the bent zone.

Table 28 : Required mechanical properties

Grade	Base material used for the tests	Transverse tensile test	
		Tensile strength R_m (N/mm ²) min.	Bend ratio and angle D/ t (1) $\alpha = 180^\circ$
RA/ WA	5754	190	3
RB/ WB	5086	240	6
RC/ WC (2)	5083	275	6
	5383 or 5456	290	6
	5059	330	6
RD/ WD	6061, 6005A or 6082	170	6

(1) D = mandrel diameter, t = specimen thickness;
bending elongation on gauge length = 2 x width of weld (to be reported for information).

(2) The minimum tensile strength is to be reported on the approval certificate.

SECTION 3

APPROVAL OF OVER WELDABLE SHOP PRIMERS

1 Application

1.1 General

1.1.1 Shop primers applied to plates and sections to be welded are to be submitted to tests to verify their suitability for welding in respect of their tendency towards porosity in fillet welds.

1.1.2 The requirements of this Article apply to the procedure for approval and periodical control tests of over weldable shop primers.

The approval is intended to be limited to the following welding processes:

- manual metal arc welding
- automatic gravity welding
- semiautomatic bare wire or flux cored arc welding.

The acceptance of primers for use with welding processes in addition to those above will be specially considered in connection with the approval of the welding procedure at the user's works.

2 Information and documentation to be submitted

2.1 General

2.1.1 The application for the approval is to be sent to ^{Tasneef} by the primer Manufacturer or authorised supplier.

2.1.2 The following information and supporting documentation, as applicable, are to be submitted:

- Manufacturer
- trade name
- components of the primer, type of diluent and mixture ratio
- instructions (preparation of surfaces, method of application, drying time, recommended dry coat thicknesses, etc.)
- specified resistance to marine atmosphere
- documentation relevant to previous tests and approvals.

3 Approval tests

3.1 General

3.1.1 Approval tests are generally intended to verify the suitability of primers to obtain welds whose defects are within the usual tolerance limits.

Primer samples for approval are to be taken from a sufficiently representative quantity of primer. Sampling procedures are to be to the Surveyor's satisfaction.

Tests may be carried out at the Manufacturer's workshop, at the user's workshop or in an adequately equipped and staffed laboratory chosen in agreement with ^{Tasneef}

Welding machines, welding procedures normally employed in shipyards and certified welders are to be used for the tests.

The primer is to be applied and measured on the test pieces in compliance with the Manufacturer's specification.

Thickness measurements are to be made using proper and calibrated equipment.

Thickness measurements of the primer applied to the samples, welding and fracture tests are to be performed in the presence of the Surveyor.

3.2 Base material

3.2.1 Normal strength hull steels or equivalent grades are to be used for the test specimens.

3.3 Filler metal

3.3.1 Approved filler metals are to be used.

3.3.2 Basic covered electrodes are to be used for manual metal arc welding while acid or rutile electrodes are to be used for gravity welding.

Filler metal for tests is chosen at the discretion of ^{Tasneef} among those usually employed in shipbuilding.

3.4 Type and dimension of test samples

3.4.1 Test samples consist of double fillet welded T-joints formed by plates of the following dimensions:

- 300mm x 120mm x 15mm for manual welding and semiautomatic bare wire and flux cored arc welding with gas shielding
- 700mm x 120mm x 15mm for automatic gravity welding.

3.5 Number of samples required

3.5.1 Different commercial brands of filler metals are to be used for the tests as follows:

- a) 4 electrodes for manual welding
- b) 1 bare wire for semiautomatic welding
- c) 2 cored wires for semiautomatic flux cored arc welding
- d) 2 electrodes for gravity welding, at least one of which is to be high efficiency.

For each brand in a), b) and c) above, two samples are required to be welded, one in horizontal position and one in vertical position, using electrodes of diameter 4 mm and wire with diameter 1,2 mm.

For each brand in d), one sample is required to be welded in horizontal position using electrodes with diameter 5 mm.

3.6 Operational procedures

3.6.1 The primer thickness (measure made on dry coat) of the test samples is to be at least 30% greater than the maximum foreseen in normal use.

The pieces are to be tack welded such as to form a T with adherent contact between the surfaces.

On one side of the T sample a fillet weld of leg size 9 mm is to be deposited.

The test fillet is to be deposited on the other side in the horizontal and vertical position as specified in [3.5] with one bead having dimensions not exceeding 7x7 mm.

Following visual examination, two auxiliary beads are to be welded along the edges of the test fillet so as to provoke fracture of its throat.

After having previously removed the first fillet, the sample is to be fractured by suitable means aiming at closing the angle of the T so as to induce a tensile stress at the root of the weld.

3.7 Test requirements

3.7.1 Visual examination is to be carried out consisting of checking the external and fractured surface to determine weld penetration and presence of worm-holes, pores and other defects.

Possible defects located within 10 mm from the ends of the weld are disregarded.

Lack of penetration having total length not exceeding 1/4 of the weld length is accepted.

Wormholes and pores having diameter not exceeding 3mm are generally acceptable where the total area of porosity is not higher than 5% of the fracture section area.

3.8 Re-tests

3.8.1 Where a maximum of two samples for each manual and semiautomatic continuous wire welding process and a maximum of one sample for the gravity welding process give negative results, re-tests on two samples for each of those which originally failed are admitted.

Both the samples of each re-test are to provide satisfactory results. Failing this, the primer is not approved.

4 Certification

4.1

4.1.1 Subject to the satisfactory outcome of the required checks and tests, *Tasneef* will issue to the Manufacturer or supplier concerned the approval certificate for the primer authorizing its use on surfaces of rolled steel product to be welded.

5 Periodical control tests

5.1

5.1.1 The approval has three-year validity and may be renewed subject to the satisfactory outcome of the periodical tests below.

The samples required, of the T type like those for approval tests, are to be welded with at least the following filler metal:

- a) 2 electrodes for manual welding
- b) 1 bare wire for semiautomatic welding
- c) 1 cored wire for semiautomatic flux cored arc welding
- d) 1 electrode for gravity welding.

For each electrode in a) above, two samples are required to be welded, one in horizontal position and one in vertical position.

For the other materials in b), c) and d), one sample is required to be welded in horizontal position.

For sampling and test procedures, materials to be employed, test requirements and re-tests, where applicable, the provisions relevant to initial type approval apply.

Re-tests, in duplicate, are accepted only where a maximum of one sample for each welding process gives negative results.

Failing this, the approval of the primer is not confirmed.

Subject to the satisfactory outcome of the required checks and tests, a new approval certificate is issued with three-year validity.

SECTION 4

APPROVAL OF WELDING PROCEDURES

1 General

1.1 Application

1.1.1 General

This Section specifies in Articles [2], [3] and [4] the requirements for the approval of welding procedures for steel materials, and in Article [6] those for aluminium alloys.

The requirements relevant to materials not covered herein are defined on a case-by-case basis following, as far as applicable, the criteria specified in this Section.

Provisions for approval of laser welding procedures of hull structural steels are given in Sec 5.

1.1.2 Special requirements

In the case of applications involving the storage and transport of liquefied gases, the requirements of Pt E, Ch 1, Sec 14 apply.

1.2 Welding procedure

1.2.1 Welding processes

The approval of the welding processes is, as a rule, required for the processes indicated below together with their relevant numbering according to ISO 4063:

- metal arc welding with covered electrode: 111
- submerged arc welding with wire electrode: 121
- flux-cored wire metal arc welding without gas shield: 114
- metal arc inert gas welding (MIG welding): 131
- metal arc active gas welding (MAG welding): 135
- flux-cored wire metal arc welding with active gas shield: 136
- flux-cored wire metal arc welding with inert gas shield: 137
- tungsten inert gas arc welding (TIG welding): 141
- plasma arc welding: 15.

1.2.2 Welding consumables

Consumables approved in accordance with the requirements of Sec 2 are to be used within the limits of their approval.

When non-approved welding consumables are used, the requirements relevant to the qualification of the welding procedures are established on a case-by-case basis.

In any event, tests on a deposited metal sample are required.

Requirements relevant to the grade of welding consumables to be used are given in Sec 2 and, in particular for welding of hull structural steels, in Part B, Chapter 1, Sez 4.

1.2.3 Welding procedure specification

A welding procedure specification is to be prepared by the Manufacturer and proposed for approval; this document is also referred to as preliminary welding specification (pWPS) and may be modified and amended during the procedure tests as deemed necessary.

In its final version, the welding procedure specification (WPS) is to include all the parameters characterising the welding process; in particular, as applicable:

- a) type of welding process and equipment, as appropriate
- b) type of joint, preparation and backing material, if any
- c) base metal and thickness range
- d) filler metal
- e) welding position
- f) minimum preheat and maximum interpass temperature
- g) post-weld heat treatment if applicable
- h) shielding gas as applicable
- i) welding parameters
- j) other information relevant to the welding techniques as applicable.

1.2.4 Welding procedure approval

Welding procedure tests, according to the proposed pWPS, are to be carried out for the approval of the welding procedure.

The test pieces are to be chosen so as to cover all the production welds in accordance with the approval range of parameters given in [2.6].

The tests for approval of the welding procedure (welding and testing) are to be witnessed by the Surveyor.

The actual parameters used for welding the approval test pieces and the results of the inspections and tests carried out are to be recorded in the WPQR (welding procedure qualification record).

The WPQR is generally prepared by the shipyard or welding shops and is to be signed for validation by the Surveyor.

1.2.5 Certificate of approval of the welding procedure

Upon the satisfactory completion of the approval tests, a certificate of approval of the welding procedure is generally issued by ^{Tasneef} to the individual users, stating the conditions of the approval of the WPS such as thickness range, positions, steel grades and additional conditions for the application of the process, as deemed necessary, on the basis of the indications already given in the WPS.

1.2.6 Inspections

Inspections and control tests may be periodically and randomly required as deemed necessary by ^{Tasneef} and are to

yield satisfactory results in order to maintain the validity of the approval.

The results of any suitable control performed during production may be accepted, to the Surveyor's satisfaction.

1.2.7 Responsibilities of the users

Irrespective of the inspections carried out by the Surveyor, the user is responsible for the use of the approved procedures, within the limits of the range qualified and the conditions stated at the time of the approval.

Compliance with the above is essential for the validity of the approval.

2 Welding procedures for C and C-Mn steels

2.1 Butt weld on plates

2.1.1 Assembly

Test pieces are to be of sufficient size to ensure a reasonable heat distribution during welding and to provide for the required test specimens, after sufficient discard at the ends.

The edge preparation and fit up are to be in accordance with the pWPS.

If tack welds are to be fused into the production joint, they are to be included in the test pieces.

The test assembly is to have the following dimensions, in mm (see Fig 1):

- a) manual or semiautomatic welding:
length $L = 350$ min.; width $W = 300$ min.
- b) automatic welding:
length $L = 1000$ min.; width $W = 400$ min.

2.1.2 Welding

Welding is to be carried out in accordance with the pWPS and under the general conditions of production welding which they represent.

The weld direction is to be perpendicular to the rolling direction of the plate and is to be marked on the test piece.

However, where impact tests are prescribed for the base metal in the transverse direction, the weld direction is to be parallel to the rolling direction of the plate.

2.1.3 Examinations and tests

Non-destructive examinations and destructive tests are to be in accordance with the requirements of Tab 1, while the

location of the test specimens is to be in accordance with Fig 2.

2.1.4 Non-destructive examinations

Non-destructive examinations are to be carried out after any required post-weld heat treatment and prior to the cutting of test specimens.

For non-post-weld treated material susceptible to hydrogen cold cracking, the non-destructive examinations are to be delayed, as appropriate.

Imperfections are to be within the specified limits of level B in ISO 5817, except for the following imperfection types for which level C applies:

- excess weld metal or convexity,
- excess throat thickness, and
- excess of penetration.

More stringent requirements may be stipulated in the applicable parts of the Rules or in individual cases as necessary.

Figure 1 : Plate butt weld test assembly

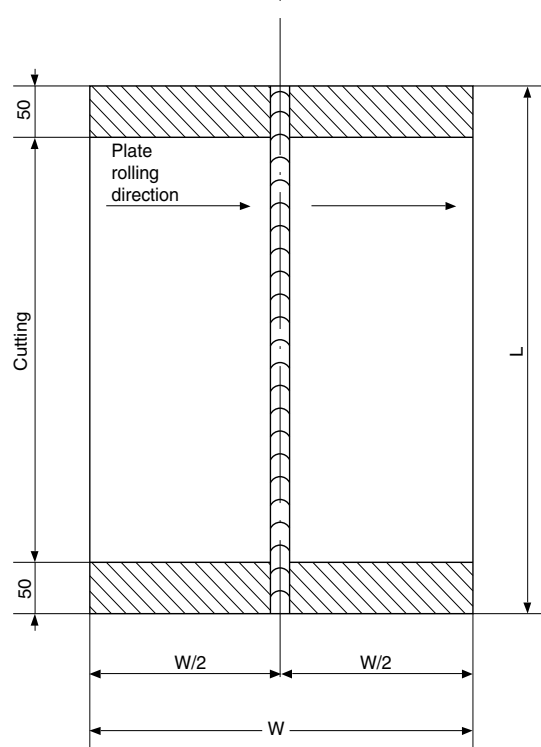

Figure 2 : Location of test specimens

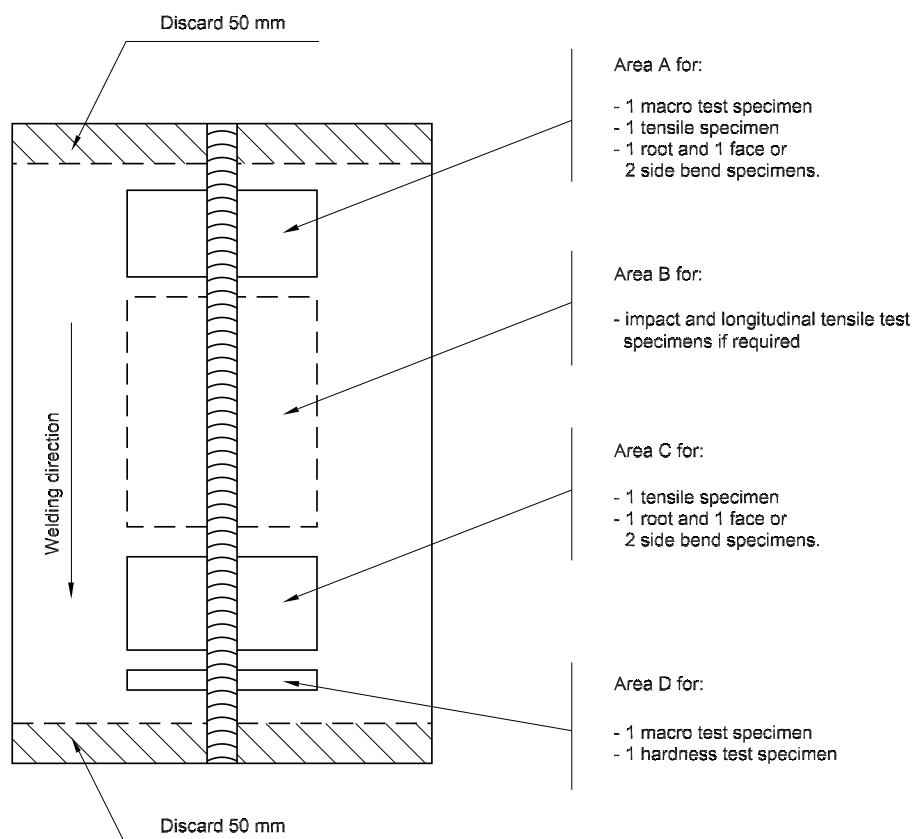

Table 1 : Examinations and tests

Type of examination or test	Extent of examination or test
Visual examination	100%
Radiographic or ultrasonic examination	100%
Surface crack detection (1)	100%
Transverse tensile test	2 specimens
Transverse bend tests (2)	2 root and 2 face specimens
Impact tests (3)	3 sets
Macro examination	2 sections
Hardness test (4)	on 1 section
Longitudinal tensile test (5)	1 specimen
<p>(1) Dye penetrant according to ISO 3452 (or equivalent accepted standard) or magnetic particle testing; for non-magnetic materials, dye penetrant only.</p> <p>(2) For $t \geq 12\text{mm}$, the face and root bends are preferably to be replaced by 4 side bends.</p> <p>(3) 3 sets each of 3 specimens as per [2.1.8].</p> <p>(4) Only required for high strength steels.</p> <p>(5) Required only when the use of non-approved filler metal has been accepted (see [1.2.2]).</p>	

2.1.5 Transverse tensile tests

Specimens for transverse tensile tests are to be in accordance with Sec 2, Fig 1.

The thickness of the test specimen is to be equal to the thickness of the parent metal near the welded joint. When the testing machine capacity does not allow testing of specimens of full thickness, multiple test specimens are to be taken to cover the full thickness of the joint and the location of the tests specimen in the welded joint thickness is to be identified.

When multiple specimens are used in lieu of full thickness specimens, each set is to represent a single tension test of the full plate thickness. Collectively, all of the specimens required to represent the full thickness of the weld at one location will comprise a set.

The tensile strength is to be not lower than the specified minimum tensile strength of the base metal; the location of the fracture is to be reported.

For joints of steels having different mechanical strength, the tensile strength is to comply with the requirement of the lower strength.

2.1.6 Tensile tests on cylindrical specimens

When required (see Tab 1), a round tensile specimen is to be cut along the weld axis to the dimension given in Ch 1, Sec 2, Fig 3, in the all weld metal.

Where the size of the deposited metal is too small, a 6 mm diameter specimen may be taken or a deposited weld metal

test is to be carried out in accordance with the requirements of Sec 2.

Where more than one welding process or type of consumable has been used to make the test weld, test specimens are to be taken from the area of the weld where each was used with the exception of those processes or consumables used to make the first weld run or root deposit.

The results of the test (yield stress R_{eH} , tensile strength R_m and elongation A_5) are to be determined and to comply with the requirements given for the approval of consumables.

2.1.7 Bend tests

Transverse root bend, face bend and side bend specimens are to be machined to the dimensions given in Sec 2, [1.5.3].

For dissimilar or heterogeneous butt-joints, one longitudinal bend test may be used instead of transverse bend tests.

The test specimens are to be bent on a mandrel having a diameter 4 times the thickness of the specimen; the bending angle is to be 180°.

During the testing, the test specimens are not to reveal any open defect, in any direction, greater than 3 mm. Defects appearing at the corner of the test specimen may be disregarded.

2.1.8 Impact tests

Charpy V-notch impact test specimens are to be taken from 1 to 2 mm below the surface of the sample (on the side containing the last run) and machined to the dimensions indicated in Ch 1, Sec 2.

Three sets of Charpy V-notch specimens (each set including 3 specimens) are to be taken as indicated in Fig 3 and Fig 4.

Test temperature and absorbed energy are to be in accordance with Table 2.

Only one individual value may be lower than the average required, provided it is not lower than 70% of it.

For joints of steels differing in impact properties, the test temperature and the impact energy are to comply with the requirements of the lower steel grade.

Unless otherwise required, the test temperature and absorbed energy of steels not covered by these requirements are to be in accordance with the specification of the parent metal.

Where more than one welding process or consumable has been used to make the test weld, impact test specimens are to be taken from the respective areas where each was employed. This is not to apply to the process or consumables used solely to make the first weld run or root deposit.

Requirements for reduced Charpy V specimens are given in Ch 1, Sec 2, [4.2.2].

Figure 3 : Locations of V-notch for butt weld of normal heat input (heat input ≤ 50 kJ/cm)

a) $t \leq 50$ mm (1)

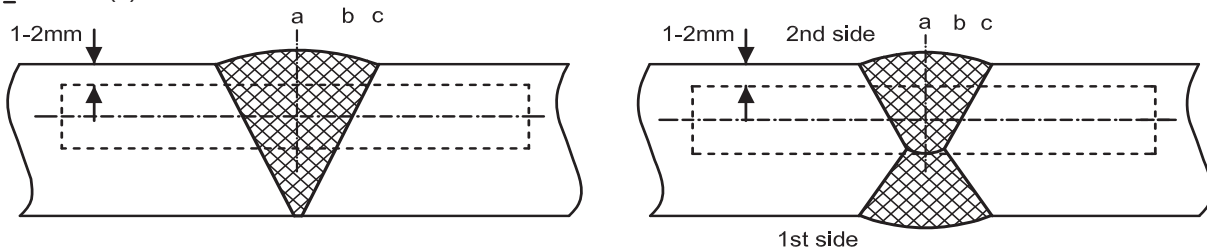

Note (1) : For one side single run welding over 20mm notch location "a" is to be added on rootside.

b) $t > 50$ mm

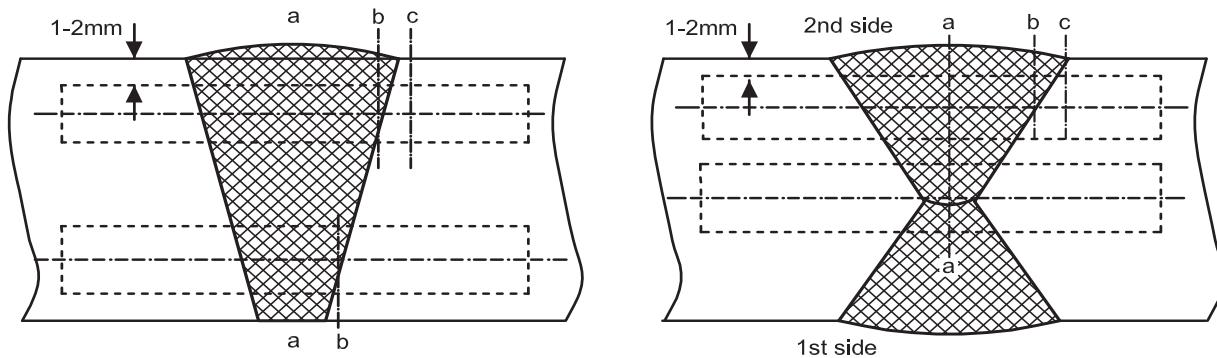

Notch locations:

- a: centre of weld "WM"
- b: on fusion line "FL"
- c: in HAZ, 2 mm from fusion line

2.1.9 Macro examinations

The test specimens are to be prepared and etched on one side to clearly reveal the fusion line, the HAZ, the build up of the runs and the unaffected parent metal.

The acceptance levels are given in [2.1.4].

2.1.10 Hardness tests

The hardness measurements are to be carried out on the macro section; normally the Vickers method HV10 is to be used.

The indentations are to be made in the weld, heat affected zones, and the parent metal with the object of measuring and recording the range of values in the weld joint. This will

include rows of indentations, one of which is to be 2mm maximum below the surface.

For each row of indentations, a minimum of 3 individual indentations is required in the weld, both sides of the HAZ and the parent metal.

For the HAZ, the first indentation is to be placed as close as possible to the fusion line.

The distance between the indentations may vary from 1 to 2 mm depending on the zone tested.

Typical example of hardness indentations are given in Fig 5.

The results of hardness tests are, as a rule, not to exceed 350 HV.

Table 2 : Impact test requirements for butt joints (t = 50 mm) (1) (2)

Grade of steel	Test temperature (°C)	Value of minimum average absorbed energy (J)		
		For manually or semi-automatically welded joints		For automatically welded joints
		Downhand, Horizontal, Overhead	Vertical upward, Vertical downward	
A (3)	20	47	34	34
B (3), D	0			
E	- 20			
A32, A36	20			
D32, D36	0			
E32, E36	- 20			
F32, F36	- 40	39	39	39
A40	20			
D40	0			
E40	- 20			
F40	- 40			

(1) For thickness above 50 mm, impact test requirements are to be agreed by Tasneef

(2) These requirements are to apply to test pieces where the butt weld is perpendicular to the rolling direction of the plates.

(3) For Grade A and B steels, average absorbed energy on the fusion line and in the heat-affected zone is to be minimum 27 J.

Figure 4 : Locations of V-notch for butt weld of high heat input (heat input > 50kJ/cm)

a) $t \leq 50$ mm (1)

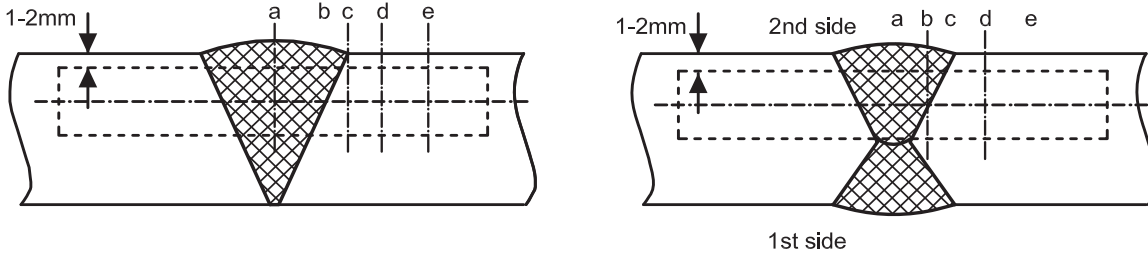

Note (1): For one side welding with thickness over 20 mm notch locations "a", "b" and "c" are to be added on root side.

b) $t > 50$ mm

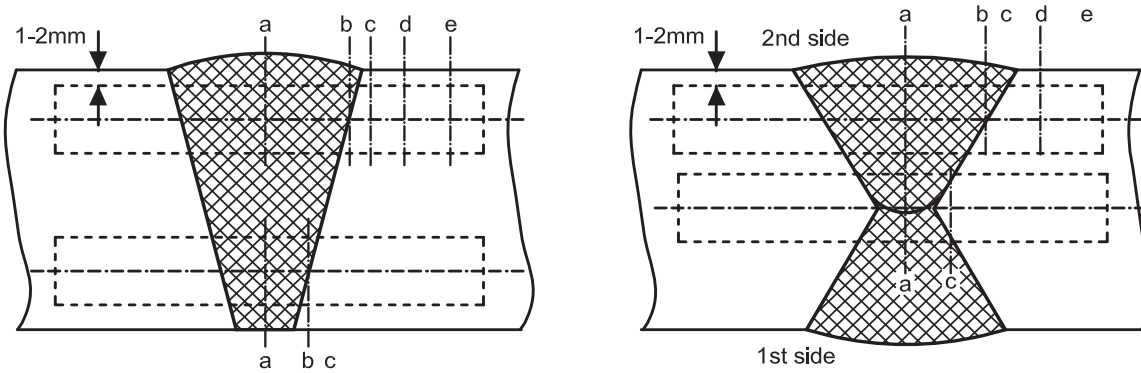

Notch locations:

- a: centre of weld "WM"
- b: on fusion line "FL"
- c: in HAZ, 2 mm from fusion line
- d: in HAZ, 5 mm from fusion line
- e: in HAZ, 10 mm from fusion line

Figure 5 : Examples of hardness indentations

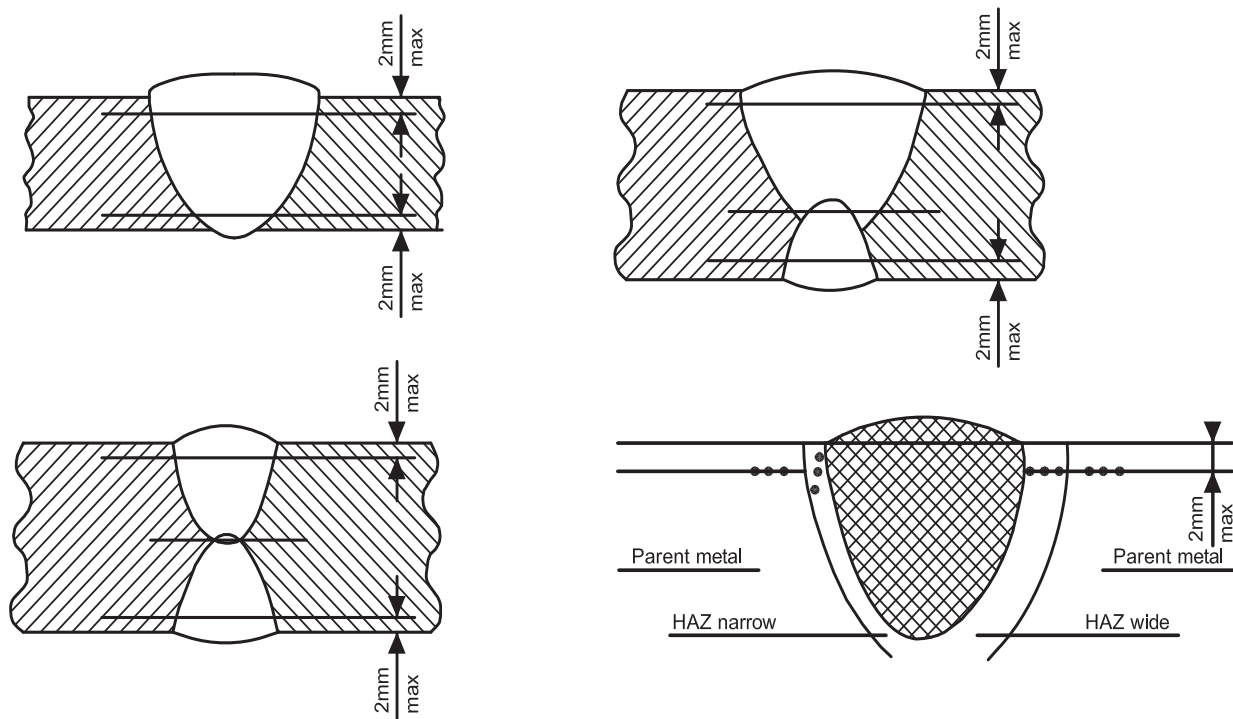

2.2 T butt-joint on plates

2.2.1 Assembly and welding

The test assembly is to be in accordance with Fig 6.

The edge preparation, fit-up and welding are to be in accordance with the pWPS.

If tack welds are to be fused into the production joint, they are to be included in the test piece.

The dimensions of the test piece are to be such as to provide for the tests in Tab 3; the minimum size of the assembly is to be:

W = 350 mm; L = 350 mm.

Figure 6 : T butt joint on plates

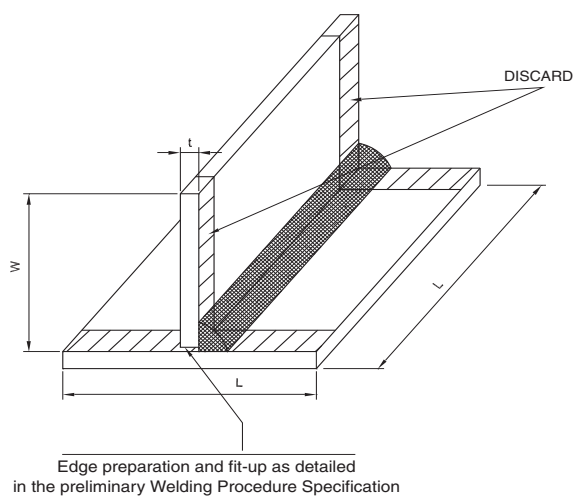

2.2.2 Examinations and tests

Non-destructive examinations and destructive tests are to be in accordance with the requirements of Tab 3; a discard of 50mm from both edges is permitted.

Additional tests for the verification of the mechanical properties of the joint should be considered when not covered by other WPS.

Table 3 : Examination and tests

Type of examination or test	Extent of examination or test
Visual examination	100%
Surface crack detection (1)	100%
Ultrasonic (2)	100%
Macro examination	2 sections
Hardness test (3)	on 1section
(1) Dye penetrant according to ISO 3452 (or equivalent accepted standard) or magnetic particle testing; for non-magnetic materials, dye penetrant only. (2) Only applicable for $t \geq 12\text{mm}$ (3) Only required for high strength steels	

2.2.3 Visual examination and surface crack detection

The requirements specified in [2.1.4] are to be complied with.

2.2.4 Macro examinations and hardness tests

The requirements specified in [2.1.9] and [2.1.10] are to be complied with as appropriate.

Typical examples of hardness indentations are given in Fig 7.

Figure 7 : Examples of hardness indentations

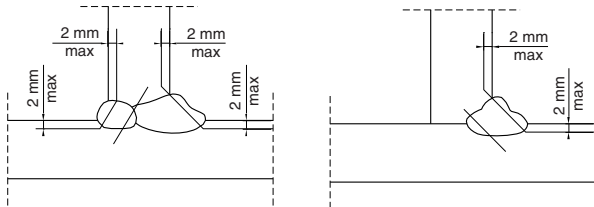

2.3 T fillet joint

2.3.1 Assembly and welding

The minimum size of test assembly is to be as follows (see Fig 8):

- a) manual or semiautomatic welding:
length L = 350 mm; width W = 150 mm
- b) automatic welding:
length L = 1000 mm; width W = 150 mm.

The two plates are to be positioned and tack welded edge-wise so as to constitute a T assembly without clearance.

Figure 8 : T fillet joint on plate

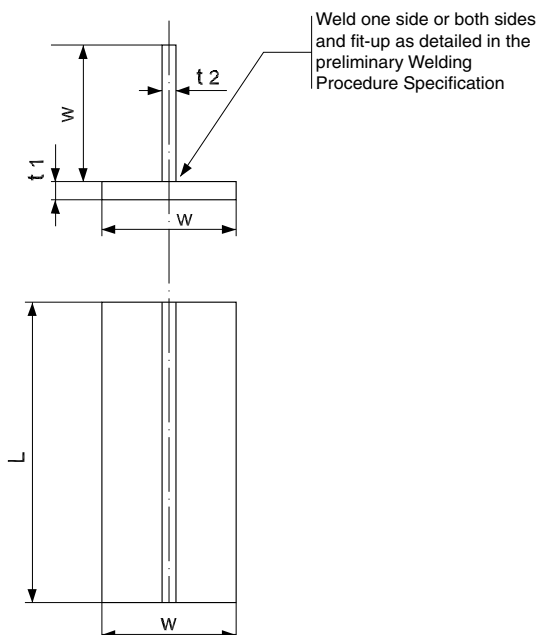

Welding on one or both sides and fit up are to be as detailed in the pWPS.

For manual and semiautomatic welding, a stop/restart position is to be included in the first run and is to be clearly marked for subsequent examination.

2.3.2 Examinations and tests

Non-destructive examinations and destructive tests are to be in accordance with the requirements of Tab 4; a discard of 50 mm from both edges is permitted.

Table 4 : Examinations and tests

Type of examination or test	Extent of examination or test
Visual examination	100%
Surface crack detection (1)	100%
Macro examination (2)	2 sections
Hardness test (3)	on 1 section
Fracture test	100%

(1) Dye penetrant according to ISO 3452 (or equivalent accepted standard) or magnetic particle testing; for non-magnetic materials, dye penetrant only.
 (2) One of the macro sections is to be taken at the position of the stop/restart; see [2.3.1].
 (3) Only required for high strength steels

2.3.3 Visual examination and surface crack detection

The requirements specified in [2.1.4] are to be complied with.

2.3.4 Macro examinations and fracture tests

The fracture of the sample is to be obtained by suitable means aimed at closing the angle of the Tee where the fillet weld has been deposited, so as to induce a tensile stress at the root of the fillet.

The result of the fracture test as well of the macro examination is to show the absence of defects, in particular lack of root penetration; when the reduction of the weld size, in association with the specific welding process, is required (see Pt B, Ch 1, Sez 4), the tests and examinations are to prove that the root penetration is not less than the applicable required value.

The dimensions of leg size, throat and penetration are to be reported. The penetration is measured by the distance 'x' in the bisector plane as indicated in Fig 9.

2.3.5 Hardness test

The indentations are to be in accordance with Fig 9 and the requirements specified in [2.1.10] are to be complied with, as appropriate.

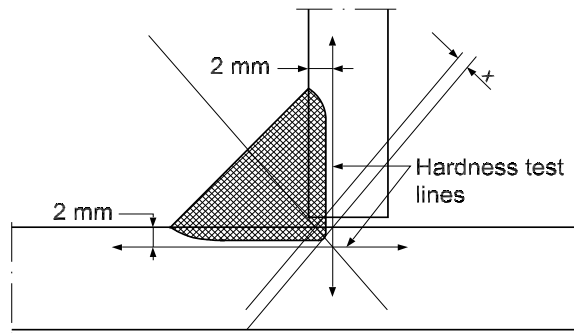
Figure 9 : Macro and hardness indentations

2.4 Butt weld on pipes

2.4.1 Assembly and welding

The test assembly is to be in accordance with Fig 10.

The edge preparation and fit-up are to be in accordance with the pWPS. The pipe diameter is to be sufficient to obtain the required specimens or, in the case of small pipe diameters, several test pieces may be necessary.

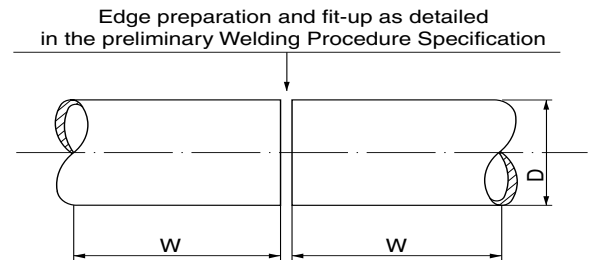
Figure 10 : Pipe weld test assembly

W : minimum value = 150 mm; D = outside diameter

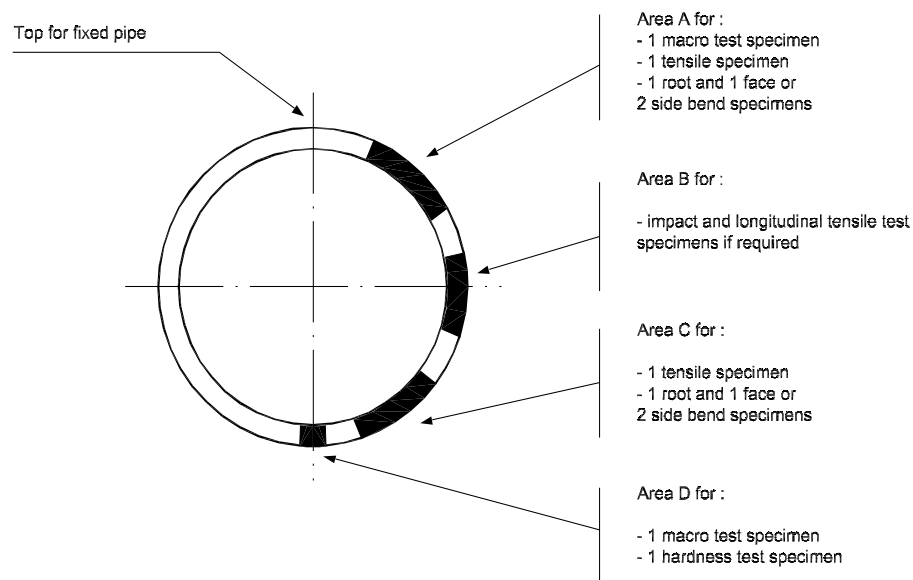
Figure 11 : Location of the test specimens

2.4.2 Examinations and tests

Non-destructive examinations and destructive tests are to be in accordance with the requirements of Tab 1, while the location of the test specimens is to be in accordance with Fig 11.

2.4.3 Results

The results are to comply with the requirements for butt tests on plates in [2.1].

2.5 Re-testing

2.5.1 If the qualification assembly fails to comply with any of the requirements for visual examination or NDE, one

extra assembly is to be welded and subjected to the same examination.

If this additional assembly does not comply with the relevant requirements, the welding process is not approved and the pWPS is to be modified before further consideration is given to a new test assembly for qualification.

2.5.2 When a destructive test (other than Charpy V for which the requirements in Sec 2, [1.7.3] apply) does not meet the requirements due to geometric welding imperfections of the specimens, two additional specimens are to be obtained for each one that failed. These tests may be taken from the same assembly if there is sufficient material, or from a new qualification test. For acceptance, both tests are to give satisfactory results.

2.5.3 If there is a single hardness value above the maximum values allowed, additional hardness tests are to be carried out (on the reverse of the specimen or after sufficient grinding of the tested surface). None of the additional hardness values is to exceed the maximum hardness values required.

2.6 Range of approval

2.6.1 General

The approval of a WPS obtained by a yard or Manufacturer is valid for all its workshops under the same technical and quality control, to Tasneef satisfaction.

Due to the influence of shop primers on quality of fillet welds, welding procedure qualification with shop primer will qualify those without but not vice versa.

The welding procedure is to be used within the range of the parameters indicated below; changes outside the range specified of one or more of these parameters require a new welding procedure test.

2.6.2 Parent metal

For each strength level, welding procedures are considered applicable to the same toughness grade as that tested and lower grades.

For each toughness grade, welding procedures are considered applicable to the same strength level as that tested and two lower strength levels.

For high heat input processes above 50kJ/cm, e.g. the two-run technique with either submerged arc or gas shielded metal arc welding, electro slag and electro gas welding, the welding procedure is applicable to that toughness grade tested and one strength level below.

Where steels used for construction are supplied in different delivery conditions from those tested, Tasneef may require additional tests.

2.6.3 Thickness

The qualification of a WPS carried out on a test assembly of thickness t is valid for the thickness range given in Tab 5.

In addition to the requirements of Tab 5, the range of approval of throat thickness "a" for fillet welds is to be as follows:

- Single run ; "0,75 a" to "1,5 a"
- Multi-run ; as for butt welds with multi-run (i.e. a=t)

For the vertical-down welding, the test piece thickness "t" is always taken as the upper limit of the range of application.

For unequal plate thickness of butt welds, the lesser thickness is ruling dimension.

Notwithstanding the above, the approval of maximum thickness of base metal for any technique is to be restricted to the thickness of the test assembly if three of the hardness

values in the heat-affected zone are found to be within 25 HV of the maximum permitted, as stated in [2.1.10].

2.6.4 Pipe diameter

Approval of a WPS carried out on a pipe of diameter D is valid for diameters in the range given in Tab 6.

2.6.5 Welding position

Unless otherwise specified on a case-by-case basis, qualification obtained for one position is extended to all the welding positions, provided that neither impact tests nor hardness tests are required.

When impact and/or hardness requirements are specified, impact tests and hardness tests are to be performed from the highest and the lowest heat input position, respectively, in order to obtain qualification for all positions.

2.6.6 Type of joint

The range of approval of the type of joints is given in Tab 7.

A new approval may also be required by the Surveyor when changes occur in the geometry of the bevel which significantly affect the penetration or fusion.

Table 5 : Approved thickness range

Thickness t of the test piece (mm) (1)	Range of approval	
	Single run or single run from both sides of butt welds and T butt-joints	Multi-run welding of butt and T butt welds and all fillet welds (2)
t ≤ 12	0,7 t to 1,1 t	3mm to 2 t (4)
12 < t ≤ 100	0,7 t to 1,1 t (3)	0,5 t to 2 t (max.150mm)
(1) For multi-process procedures, the recorded thickness contribution of each process is to be used as a basis for the range of approval for the individual welding process. (2) For fillet welds, the range of approval is to be applied to both base metals. (3) For high heat input processes over 50kJ/cm, the upper limit of range of approval is to be 1,0 t. (4) For thickness of the test piece less than 3 mm, the minimum thickness approved is the thickness welded.		

Table 6 : Approved diameter range

Diameter of the test piece (mm)	Range of approval (1)
D < 168,3	0,5 D to 2 D
D ≥ 168,3	≥ 0,5 D and plates
(1) Qualification given for plates also covers pipes with outside diameter > 500 mm.	

Table 7 : Range of approval for type of joint

Type of joint in the approval test piece			Range of approval						
			Butt welds on plate				T butt joints on plate		Fillet welds on plate and pipe
			Welded from one side		Welded from bothsides		Welded from one side	Welded from both sides	
			With backing	No backing	With gouging	No gouging			
Butt weld on plate	One side (1)	With backing	◇	-	x	x	x (2)	x	x
		No backing	x	◇	-	x	x	x	x
	Both sides	With gouging	-	-	◇	-	-	x	x
		No gouging	-	-	x	◇	-	x	x
T butt weld on plate	One side	-	-	-	-	◇	x	x	
	Both sides	-	-	-	-	-	◇	x	
Fillet weld	Plate	-	-	-	-	-	-	◇	

Note 1:
◇ indicates the type of assembly which is qualified in the approval test.
x indicates those welds for which the WPS is also approved.
- indicates those welds for which the WPS is not approved.
(1) Butt welds on a plate welded from one side approve butt welds on pipes having diameter > 500mm within the limitations of the table.
(2) with backing

2.6.7 Welding process

Changes in the welding process and/or type of current (a.c., d.c., pulsed) require a new welding procedure approval.

It is not permitted to change from a multi-run to a single run. For multi-process procedures the welding procedure approval may be carried out with separate welding procedure tests for each welding process. It is also possible to conduct the welding procedure test as a multi-process procedure test. The approval of such a test is only valid for the process sequence carried out during the multi-process procedure test.

2.6.8 Welding consumables

Changes in the type and/or trade name of filler metal require a new welding procedure approval.

Reduction of applicable tests may be considered in the case of 111, 141, 131 and 135 processes.

2.6.9 Submerged arc welding (12)

In the submerged arc process, the approval obtained is restricted to the wire system used in the approval test (e.g. single wire or multi-wire) and relevant welding technique (T, M, U).

2.6.10 Gas metal arc welding (131, 135, 136)

The approval obtained for face and/or back shielding gas is restricted to the type of gas (nominal composition) used during the procedure test.

The approval is restricted to the wire system used in the approval test (e.g. single wire or multi-wire) and, in the case of automatic welding, to the relevant welding technique.

2.6.11 Manual metal arc welding (111) and semiautomatic welding process with flux cored wire without gas shield (114)

The approval obtained is valid for the diameter of the electrode used in the welding procedure test plus or minus one electrode diameter size for each run, except for the root run of the one side welded assembly without backing strip, for which no size change is allowed.

2.6.12 Heat input

When impact requirements apply, the upper limit of heat input qualified is 25% greater than that used during the welding procedure test or 55kJ/cm, whichever is the lesser, except that the upper limit is 10% greater than that for high heat input processes over 50kJ/cm.

When hardness requirements apply, the lower limit of heat input qualified is 25% lower than that used during the welding procedure test.

2.6.13 Preheat and interpass temperature

The lower limit of approval is the nominal preheat at the start of the welding procedure test.

The upper limit of approval is the nominal interpass temperature reached in the welding procedure test.

2.6.14 Post-weld heat treatment

The addition or deletion of a post-weld heat treatment requires a new welding procedure approval.

Holding time may be adjusted as a function of thickness.

3 Welding procedures for Cr-Ni austenitic and austenitic-ferritic stainless steels for application with chemicals

3.1 General

3.1.1 Test pieces, tests and requirements for the approval of the welding procedures are stated on a case-by-case basis, according to criteria analogous to those specified in [2.1] to [2.6].

3.1.2 Checks of the chemical composition of the welded zone may be required and, in the case of austenitic-ferritic steels, the examination of the metallographic structure for the determination of the ferrite content is generally to be performed (value required according to ASTM E 562: 25-70%).

Impact tests are not required in the case of austenitic steels and are to be performed at -20°C in the case of austenitic-ferritic steels; the average value for the absorbed energy is to be not lower than 27 J.

Corrosion tests according to recognised standards may be required depending on the type of steel.

3.1.3 Indications relevant to the approval class of consumables and parent metal which can be welded are given in Tab 8.

4 Approval of welding procedures for high strength quenched and tempered steels

4.1 General

4.1.1 Test pieces, tests and requirements for the approval of the welding procedures are stated on a case-by-case basis, according to criteria analogous to those specified in [2.1] to [2.6], unless otherwise specified in this Article.

4.1.2 The bend specimens are to be bent on a mandrel having diameter 5 times the specimen thickness in the case of steel types B420, B460 and B500, and 6 times the specimen thickness in the case of steel types B550, B620 and B690.

The Vickers hardness values HV10 are, as a rule, to be not higher than 420 HV.

4.1.3 Mechanical tests on all weld metal may be required on a case-by-case basis.

4.1.4 The approval of the procedures is generally restricted to the individual specification of the steel used in the approval tests.

5 Approval of welding procedures for forgings and castings

5.1 General

5.1.1 Test pieces, tests and requirements for the approval of the welding procedures are stated on a case-by-case

basis, according to criteria similar to those specified in [2.1] to [2.6], unless otherwise specified in this Article.

5.1.2 For base metal with specified impact values, test temperature and absorbed energy are to be in accordance with the requirements of the base metal to be welded.

5.1.3 Welding procedures are considered applicable to the same strength level as that tested and to lower strength levels.

5.1.4 The approval of quenched and tempered hull steel products does not qualify other delivery conditions and vice versa.

6 Approval of welding procedures for aluminium alloys

6.1 Butt weld on plates

6.1.1 Assembly and welding

The requirements of [2.1.1] and [2.1.2] apply.

The cleaning of the parts to be welded is to be carried out with appropriate procedures which are then to be followed in the construction.

Welding consumables are to be approved by ^{Tasneef} in accordance with Sec 2, [14].

6.1.2 Examinations and tests

Non-destructive examinations and destructive tests are to be in accordance with the requirements of Tab 9, while the location of the test specimens is to be in accordance with Fig 2.

6.1.3 Non-destructive examinations

Non-destructive examinations are to be carried out after any required post-weld heat treatment and natural or artificial aging, and prior to the cutting of test specimens.

Welds are to be reasonably free from defects. In particular, cracks are not allowed; inclusion of oxides may be permitted where of limited extent and widely scattered (single porosity having diameter between 0,5 and 1,5 mm may be accepted as well as short lengths of weld with in-line porosity or small $\leq 0,5$ mm scattered porosity).

For the evaluation of the results of the radiographic examination, it should be borne in mind that in-line porosity is frequently associated with widespread inclusions of oxides; in such cases it may be advisable to require fracture test specimens obtained in the way of the in-line porosities.

Defects are to be within the specified limits of level B in ISO/DIS10042.2, except for the following imperfection types, for which level C applies: excess weld metal or convexity, excess throat thickness and excess penetration.

More stringent requirements may be stipulated in the applicable parts of the Rules or required on a case-by-case basis.

Table 8 : Selection of consumable approval grades suitable for welding Cr-Ni austenitic steels

Consumable approval grade	Steels which can be welded
308	304
308L	304 - 304L
316	304 - 316
316L	304 - 304L - 316 - 316L
316LN	304 - 304L - 316 - 316L - 316LN - 316Ti - 316Nb
317	304 - 316 - 317
317L	304 - 304L - 316 - 316L - 317 - 317L
309	309 (1)
309L	309 - 309L (1)
309 Mo	309 - 309Mo - 316 (1)
310	310 (1)
310Mo	310 - 310Mo (1)
347	321 - 347
(1) Also heterogeneous joints between ferritic and austenitic steels	

6.1.4 Transverse tensile tests

Specimens for transverse tensile tests are to be in accordance with Fig 12.

The weld is to be made flush maintaining the thickness of the assembly.

Table 9 : Examinations and tests

Type of examination or test	Extent of examination or test
Visual examination	100%
Radiographic or ultrasonic examination	100%
Dye penetrant test	100%
Transverse tensile tests	2 specimens
Transverse bend tests (1)	2 root and 2 face specimens
Macro examination	1 section
Check of Mg content (2)	weld metal
(1) The face and root bends are preferably to be replaced by 4 side bends for $t \geq 12$ mm.	
(2) In the case of non-approved filler metal, the check of Mg content and other checks, as appropriate, are generally required.	

Figure 12 : Transverse tensile specimen

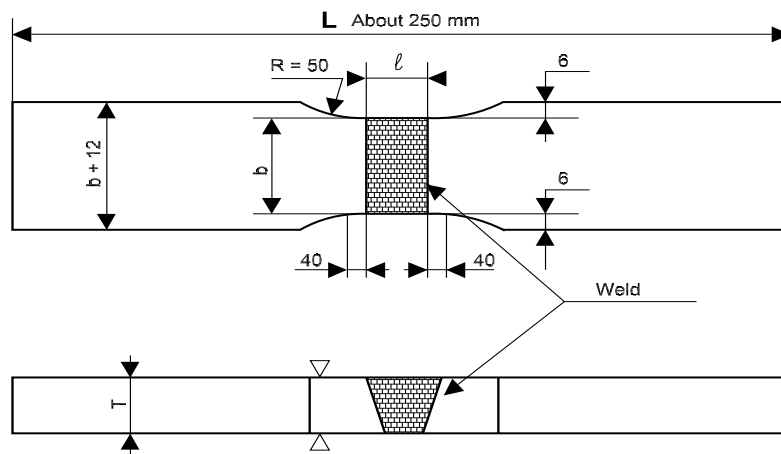

l = widest part of the weld line
 $b = 38 \pm 0,25$ mm, if $t \leq 25$ mm
 $b = 25 \pm 0,25$ mm, if $t > 25$ mm.

Table 10 : Specified mechanical properties for series 6000 extruded products

Alloy	Temper	Yield strength $R_{p0.2}$ min. (N/mm ²)	Tensile strength R_m min. (N/mm ²)	Tensile strength after welding R_m min. (N/mm ²)
6005 A	T5, T6	215	260	150
6005 A (closed sections)	T5, T6	215	250	150
6061	T4, T5, T6	240	260	150
6061 (closed sections)	T4, T5, T6	205	245	150
6082 (sections)	T4, T5, T6	260	310	165
6082 (closed sections)	T4, T5, T6	240	290	165

For series 5000 alloys, the tensile strength of the test specimen is to be not lower than the specified minimum tensile strength of the parent metal in the soft condition: 0 or H111 (see Ch 3, Sec 2).

For series 6000 alloys, the tensile strength of the test specimen is to be not lower than the specified minimum value of the parent metal after welding given in Tab 10.

6.1.5 Bend tests

Transverse root bend, face bend and side bend specimens are to be machined to the dimensions given in Sec 2, [1.5.3].

For dissimilar or heterogeneous butt joints, one longitudinal bend test may be used instead of transverse bend tests.

The test is to be carried out on a mandrel having diameter 6t for series 5000 alloys (except alloy 5754) or 7t for series 6000 alloys, t being the thickness of the specimen; for alloy 5754, the mandrel diameter is to be 4t. The bending angle is to be 180°.

The “wrap around bending method” is the recommended bending procedure in lieu of the usual “free” bend test (see Fig 13).

During the testing, the test specimens are not to reveal any open defect, in any direction, greater than 3 mm. Defects appearing at the corner of the test specimen are disregarded.

6.1.6 Macro examination

The test specimens are to be prepared and etched on one side to clearly reveal the fusion line, the HAZ, the build up of the runs and the unaffected parent metal. The examination is to reveal a regular weld profile, thorough fusion between adjacent layers of weld and base metal, and the absence of defects such as cracks and lack of fusion.

The acceptance levels of other imperfections are given in [6.1.3].

6.2 T fillet joint

6.2.1 Assembly and welding

The requirements of [2.3.1] apply.

The plate thickness is to be close to the average value of proposed range of thickness; the throat thickness of the weld is to be appropriate to the thickness of the web of the T.

The cleaning of the parts to be welded is to be carried out with the same procedure to be used in the construction.

6.2.2 Examinations and tests

Non-destructive examinations and destructive tests are to be in accordance with the requirements of Tab 11; a discard of 50 mm from both edges is allowed.

Table 11 : Examinations and tests

Type of examination or test	Extent of examination or test
Visual examination	100%
Dye penetrant test	100%
Macro examination (1)	2 specimens
Fracture test	2 specimens
(1) One of the macro sections is to be taken at the position of the stop/restart (see [2.3.1]).	

6.2.3 Visual examination and surface crack detection

The requirements specified in [6.1.3] are to be complied with.

6.2.4 Macro examination and fracture test

The result of the fracture test as well as the macro examination are to show the absence of defects, in particular lack of root penetration.

Defects such as blowholes or inclusions are not to exceed 6% of the fracture section examined.

The dimensions of leg size, throat and penetration are generally to be reported.

6.3 Range of approval

6.3.1 General

Unless otherwise specified in this Article, reference may be made to the requirements in [2.6].

6.3.2 Parent metal

A welding procedure test is generally required for each grade of aluminium alloy.

6.3.3 Welding positions

The test pieces are to be welded in the most unfavourable of the welding positions used in construction (vertical and overhead positions, as applicable).

Figure 13 : Wrap around bend test

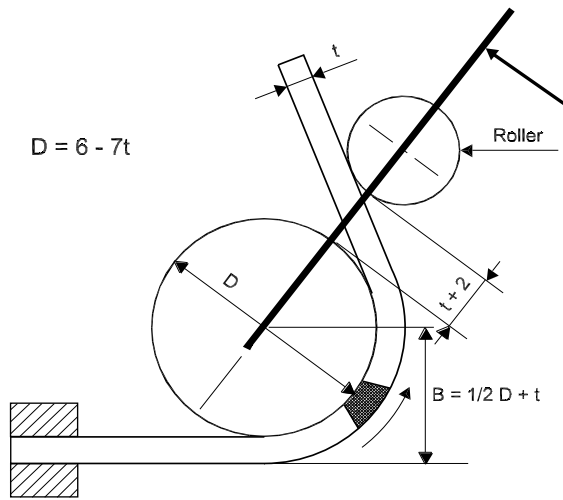

The fixed edge of the test specimen is to be clamped to avoid sliding. The whole welded zone (weld and heat affected zone), in the case of transverse bending, is to be entirely positioned in the bent zone.

7 Approval of welding procedures for repair of propellers

7.1 General

7.1.1 The provisions of this Article apply to the approval of welding procedures to be used for repair by welding of cast copper alloy or cast steel propellers or propeller blades, as applicable.

7.1.2 The welding of the procedure qualification test sample is to be carried out in accordance with the pWPS prepared by the company wishing to carry out welding work and under the general conditions of production welding which they represent. Filler metal, preheating and stress relieving heat treatment are to be the same as adopted in the repair work.

7.2 Assembly and welding

7.2.1 A butt weld test sample of minimum 30mm thickness is to be welded in the flat position. Dimensions of test samples and types and dimensions of the test specimens to be prepared are shown in Fig 14 and Fig 15 for cast copper alloy propellers and cast steel propellers, respectively.

Figure 14 : Test sample for cost copper alloy propellers

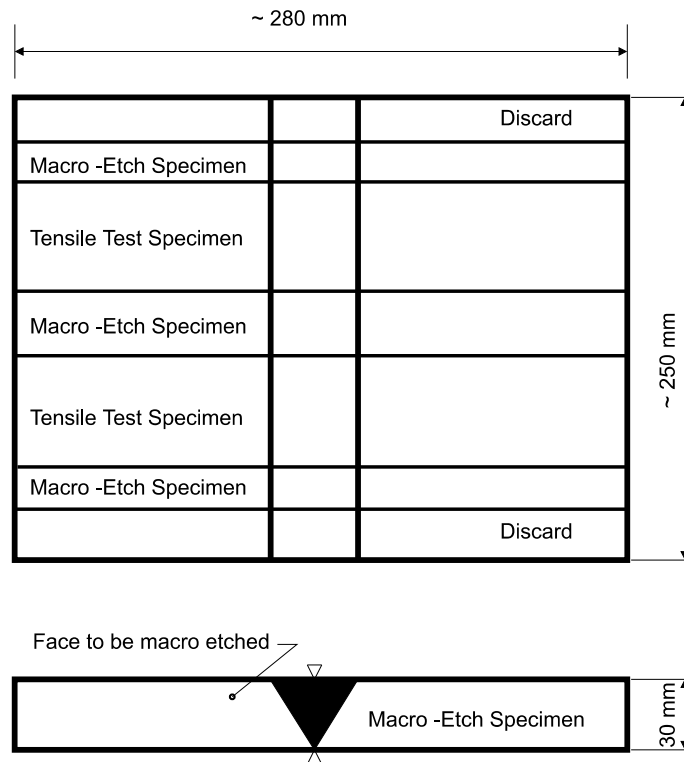
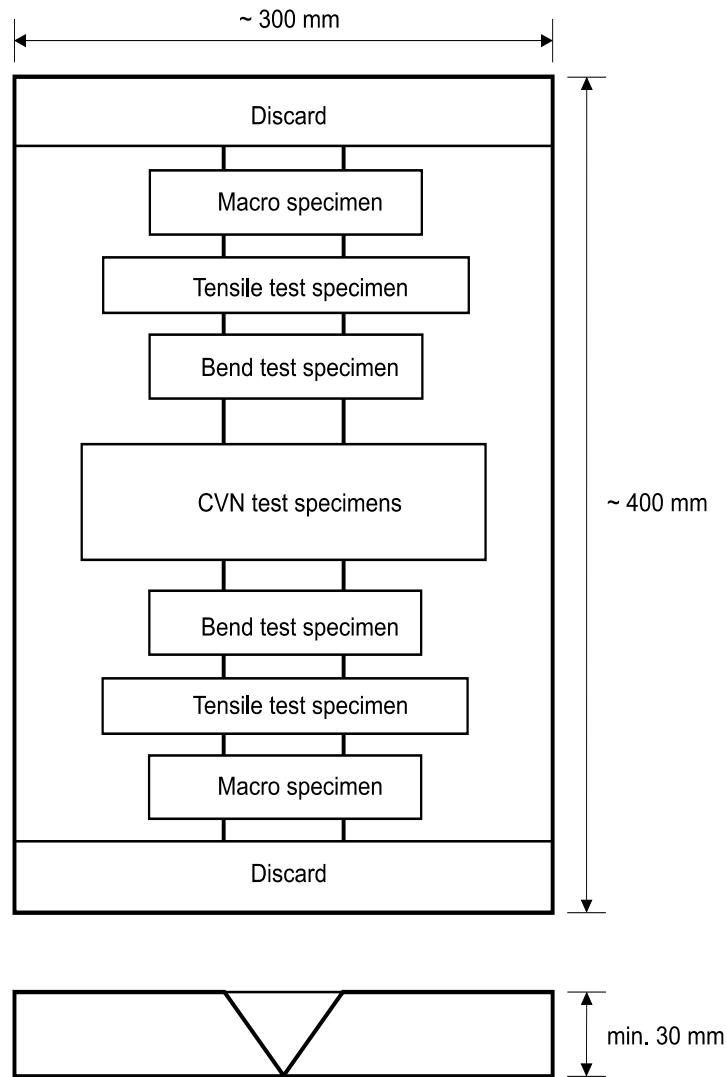

Figure 15 : Test sample for cast steel propellers



7.2.2 The cleaning of the parts to be welded is to be carried out with appropriate procedures which are to be followed in the repair work.

7.3 Examination and tests

7.3.1 Non-destructive examination

Prior to sectioning, the test assembly is to be visually inspected and 100% tested by liquid penetrant examination. The evaluation of the imperfection is to be in accordance with Ch 4, Sec 2, [1.10].

7.3.2 Macro examination

The test specimens are to be prepared and etched on one side to clearly reveal the weld metal, the fusion line, the HAZ, the build up of the runs and the unaffected parent metal. The sections are to be examined by eye (aided by low power hand lens if necessary) for any imperfections present in the weld metal and the HAZ. Cracks or crack-like imperfections, slag inclusions and pores greater than 3 mm are not permitted.

7.3.3 Transverse tensile test

Two flat transverse tensile test specimens are to be prepared in accordance with Sec 2, Fig 1. The tensile strength is to be not lower than:

- for cast steel propellers: the specified minimum value of the base material;
- for cast copper alloy propellers: the values specified in Tab 12.

The location of the fracture is to be reported.

Table 12 : Required tensile strength values for cast copper alloy propellers

ALLOY TYPE	TENSILE STRENGTH, N/mm ² (minimum)
CU 1	370
CU 2	410
CU 3	500
CU 4	550

7.4 Additional test for cast steel propellers

7.4.1 Bend tests

Two side bend test specimens are to be prepared in accordance with Sec 2, [1.5.4]. The former diameter is to be 4 x thickness except for austenitic steels, in which case the former is to be 3 x thickness. When visually inspected after bending, the test specimens are to show no surface imperfections greater than 2mm in length.

7.4.2 Impact tests

Impact tests are not required, except where the base material is impact tested. Two sets of Charpy V- notch test specimens, one set with the notch positioned in the centre of the

weld and one set positioned in the fusion line, are to be prepared in accordance with Ch 1, Sec 2.

The test temperature and the impact energy are to comply with the requirement specified for the base material.

7.4.3 Hardness tests

One of the macro sections is to be used for HV5 hardness testing. A row of indentations is to be made 2 mm below the surface. At least three individual indentations are to be made in the weld metal, both sides of the HAZ and both sides of the base material. The values are to be reported for information.

SECTION 5

APPROVAL OF CO₂ LASER WELDING PROCEDURES

1 General

1.1 Application

1.1.1 The requirements of this Section apply to the approval of CO₂ laser welding procedures for butt- and T-joints in hull construction. Stake welding is not covered by these requirements.

1.2 General requirements

1.2.1 The user's workshop is to furnish proof, by means of a weld procedure approval test and examination of the first production welds, that the welds produced under the normal conditions are sound and have the required mechanical properties.

1.2.2 The approval is granted for a defined range of applications (materials, plate thicknesses, seam preparation, tolerances, etc.) and for specific characteristic welding parameters (laser power, welding speed, welding consumables, etc.), in accordance with the samples welded during the procedure qualification tests.

Normally, changes in essential variables outside the approved range (see Article [7]) require supplementary tests or complete re-qualification.

1.3 Welding personnel

1.3.1 The personnel operating laser welding systems are to have been trained as appropriate and to be capable of making all required adjustments in accordance with the welding specification.

The personnel are also to be in a position to identify any problems in the welding equipment or process and to initiate adequate remedial actions. Proof of this is to be furnished within the scope of the procedure approval tests.

1.4 Welding procedure specification

1.4.1 A welding procedure specification is to be prepared by the Manufacturer and proposed for approval; this document is also referred to as preliminary welding procedure specification (pWPS) and is to be modified and amended during the procedure tests as deemed necessary.

In its final version, the welding procedure specification (WPS) is to include all the welding parameters and main data affecting the quality of welded joints and is to be used as a basis for the laser production welds.

1.5 Parent metal

1.5.1 In addition to the structural steels defined in Ch 2, Sec 1, [2], two new grades of steel have been defined with a

narrower range of chemical composition (thus allowing wider flexibility of laser welding parameters).

These grades, designated L24 (normal steel) and L36 (higher strength steel), have the chemical composition indicated in Tab 1; for elements not indicated in this Table, the limits are those of the standard steels defined in Ch 2, Sec 1, Tab 2. The steels are to comply with the requirements in Ch 2, Sec 1, [2].

1.5.2 Steels having chemical composition different from that indicated in Tab 1 may be used provided that satisfactory results are obtained in the approval tests and production welds.

In particular, the following deviation from the standard composition given in Tab 1 may be specially considered subject to an adequate limitation of the welding speed, e.g. 0,6m / 1' for a thickness of 12 mm or 2m / 1' for a thickness less than or equal to 6 mm:

- C ≤ 0,15% subject to a reduction in welding speed and/or increase in applied energy in respect of the values found adequate for the maximum level of C 0,12%,
- S ≤ 0,010% and P ≤ 0,015% for a material thickness less than or equal to 12 mm, or
- S ≤ 0,017% and P ≤ 0,018% for a material thickness less than or equal to 6 mm.

Table 1 : L24 and L36 steel chemical composition

Elements	Ladle analysis (%)
C	≤ 0,12
Mn	0,90 - 1,60 (1)
Si	0,10 - 0,50
S	≤ 0,005
P	≤ 0,010
C _{EQ} (2)	≤ 0,38
P _{cm} (3)	≤ 0,22
(1) Manganese may be reduced to 0,70% for L24 grade consistent with the lowest values used in the weld procedure test.	
(2) $C_{EQ} = C + \frac{Mn}{6} + \frac{Cr + Mo + V}{5} + \frac{Ni + Cu}{15}$ %	
(3) $P_{cm} = C + \frac{Si}{30} + \frac{Mn}{20} + \frac{Cu}{20} + \frac{Ni}{60} + \frac{Cr}{20} + \frac{Mo}{15} + \frac{V}{10} + 5B$ %	

1.6 Welding consumables

1.6.1 Welding consumables and auxiliary materials are to be approved by Tasneef and are to be clearly defined in the WPS.

2 Welding procedure

2.1 General

2.1.1 Prior to fabrication, welding procedure tests are to be carried out under *Tasneef* supervision at the user's workshop under fabrication conditions.

2.1.2 Prior to the welding of the procedure tests, a test program is to be submitted to *Tasneef* for examination and approval.

2.1.3 The application of the welding procedure is subject to the acceptance of the first production welds.

2.2 Assembly and welding

2.2.1 Butt-joint test assemblies and/or T-joint test assemblies are to be welded in the procedure test in accordance with the range of application applied for approval.

2.2.2 Test assemblies are to be of a sufficient size to ensure reasonable heat distribution during welding and to provide for the required test specimens, after sufficient discard at the ends.

Unless otherwise agreed, the dimensions are to be in accordance with [4.1.2] and [5.1.1].

2.2.3 Welding is to be carried out in accordance with the WPS and under the general conditions of production welding which they represent.

2.2.4 The type of joint preparation including tolerances is to be representative of the fabrication welds. Maximum and minimum values of tolerances are to be incorporated in the weld procedure test.

Where gaps are required, the minimum and the maximum values are to be verified on two procedure tests.

2.2.5 The plates are to be held in place by clamps, or other suitable holding devices, or by tack welds as provided for fabrication welding. If tack welds are to be used in the fabrication, they are to be included in the test pieces.

2.2.6 The welding parameters are to be recorded and are to be in accordance with the WPS. Each test piece is to contain at least one sudden stop/restart of the welding process.

3 Non-destructive examinations

3.1 General

3.1.1 Prior to the cutting of the test specimens, non-destructive examinations are to be carried out over the entire length of the weld.

3.1.2 Where automatic non-destructive examinations are used in fabrication (e.g. ultrasonic), the test piece is to be subjected to such examinations.

3.2 Visual examination

3.2.1 Visual examination is to be performed on all butt- and T-joints for external imperfections (cracks, porosity, lack of penetration, undercuts, excess weld metal, excessive penetration or root reinforcement, linear misalignment, sagging, incomplete filled groove, root concavity shrinkage groove, etc.) in accordance with prEN 1419/ISO DIS 13919 "Electron and laser beam welded joints in steel". Imperfections are to be within the limits specified for quality level C (intermediate).

3.3 Radiographic examination

3.3.1 Radiographic examination is to be performed on all butt-joints in accordance with prEN 1435/ISO 1106 using X rays and fine grain films (type C according to prEN 584) with lead screens. Imperfections (cracks, including crater cracks, porosity and gas pores, shrinkage cavities, solid inclusions, lack of fusion, lack of penetration, etc.) are to be evaluated in accordance with prEN 1419/ISO DIS 13919, mentioned in [3.2.1], and are to be within the limits specified for quality level C (intermediate).

Any linear indications on the film originating from solidification imperfections are considered as cracks and are not acceptable.

3.4 Ultrasonic examination

3.4.1 Ultrasonic examination is to be performed on all full penetration T-joints in accordance with prEN 1714 using straight probes (from the face plate side) and angle probes (from the web side).

Ultrasonic examination of butt-joints may also be required by *Tasneef*. The test methods (calibration, sensitivity, setting, testing direction, angle of incidence, etc.) are to be specified depending on the material thickness to be joined and are to be submitted to *Tasneef* for approval. Additional samples for macro examination are to be taken from areas showing significant indications.

3.5 Magnetic particle

3.5.1 Magnetic particle examination is to be performed on all butt- and T- joints in accordance with prEN 1290 for surface imperfections such as cracks, including crater cracks, and lack of fusion and/or penetration. Where necessary (in the case of doubt), the weld reinforcement of butt welds is to be ground flush with the surface after visual, radiographic and ultrasonic examination. Linear indications are not acceptable.

4 Butt weld procedure test

4.1 Assembly

4.1.1 The weld direction is to be perpendicular to the rolling direction of the plate and is to be marked on the test piece.

Where impact tests are prescribed for the base metal in the transverse direction, the weld direction is to be parallel to the rolling direction of the plate (see Fig 1).

Figure 1 : Butt weld test assembly with Charpy impact test

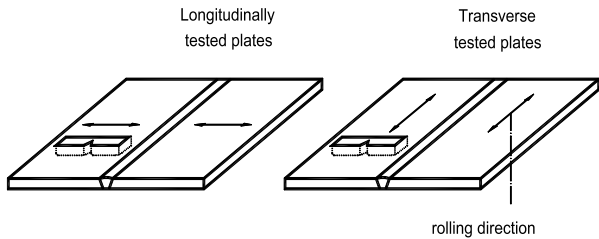

4.1.2 The dimension of the butt weld test assembly is to be in accordance with Fig 2.

The dimensions in Fig 2 are as follows:

- W min. = 1000 mm
- L min. = 1500 mm
- D max. = 50 mm.

4.2 Examinations and tests

4.2.1 General

Non-destructive examinations and destructive tests are to be in accordance with the requirements of Tab 2, while the location of the test specimens is to be in accordance with Fig 2.

4.2.2 Non-destructive examinations

The requirements in Article [3] are to be complied with. Special attention is to be paid to the stop/restart positions with respect to profile, proper fusion and absence of cracks and porosity.

4.3 Tensile tests

4.3.1 Transverse tensile test specimens are to be in accordance with Sec 2, Fig 1; the testing method is to be in accordance with Ch 1, Sec 2.

4.3.2 The tensile strength is to be not lower than the specified minimum tensile strength of the parent material. The location of the fracture is to be reported, i.e. weld metal, HAZ, parent metal.

Table 2 : Examinations and tests

Type of examination or test	Extent of examination or test
Visual examination	100%
Radiographic examination	100%
Magnetic particle examination	100%
Transverse tensile test	2 specimens
Transverse bend tests (1)	2 root and 2 face specimens
Longitudinal bend test	1 face specimen
Impact tests (2)	3 sets
Macro examination	3 sections
Hardness test	2 sections
(1) The face and root bends are preferably to be replaced by 4 side bends for $t \geq 12$ mm.	
(2) 3 sets of 3 specimens as per [4.5.1].	

4.4 Bend tests

4.4.1 Bend test

Transverse, side and longitudinal bend specimens are to be machined to the dimensions given in Sec 2, [1.5].

The test specimens are to be bent on a mandrel having a diameter 3,5 times the thickness of the specimen; the bending angle is to be 180°.

Figure 2 : Butt weld test assembly

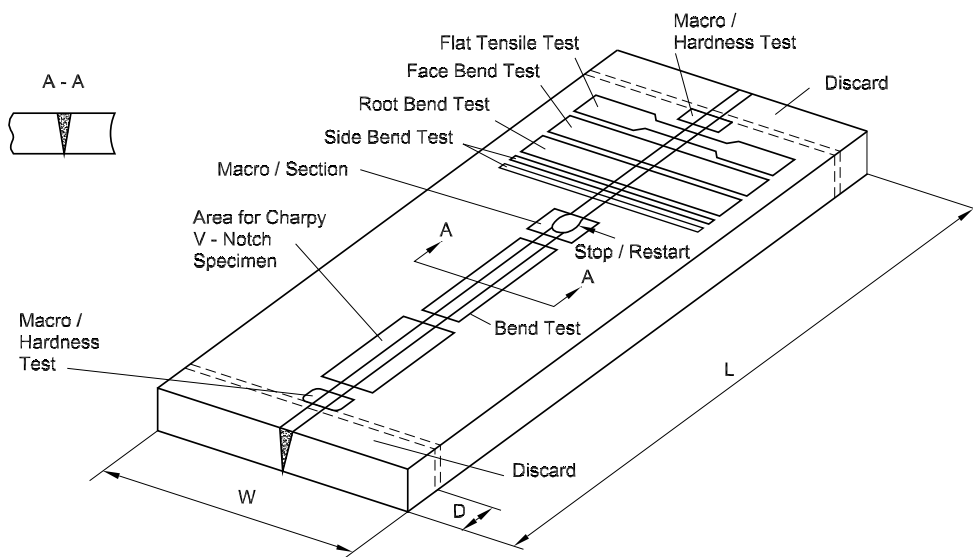

4.4.2 During the test, the specimens are not to reveal any open imperfection, in any direction, greater than 2 mm. Defects appearing at the corner of the test specimen are disregarded.

4.5 Impact tests

4.5.1 Charpy V-notch impact tests are to be taken 1 mm below the surface of the sample transverse to the weld and with the notch perpendicular to the material surface; they are to be machined to the dimensions indicated in Ch 1, Sec 2, [4.2.1].

Three sets of Charpy V-notch specimens, each set including 3 specimens, are to be taken as follows:

- one set with the notch along the weld metal centre line with tolerance $\pm 0,1\text{mm}$
- one set with the notch in the heat affected zone (HAZ)
- one set with the notch in the parent metal.

The direction of fracture is to coincide with the weld direction (see Fig 3). The parent material specimens are to have the same orientation as the specimens from the weld joint.

Figure 3 : Fracture direction of Charpy impact tests

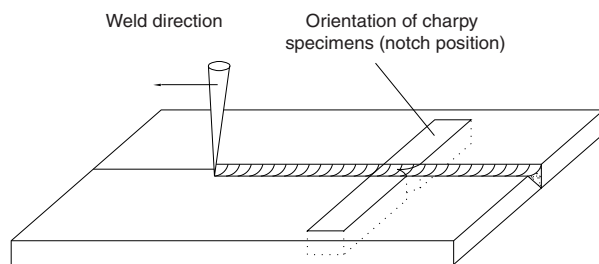

4.5.2 The test temperature and the results are to comply with the requirements specified for the parent metal.

4.5.3 Requirements for reduced Charpy V specimens are given in Ch 1, Sec 2, [4.2.2].

4.5.4 *Tasneef* may require additional tests, e.g. Charpy tests with other notch locations, and other or additional temperatures or CTOD tests.

4.6 Hardness measurements

4.6.1 Hardness test

The measurement is to be carried out in accordance with ISO 6507-1 on the macro sections required in [4.7]; the Vickers method HV5 is to be used.

The indentations are to be made in the weld, heat affected zones (HAZ) and the parent metal, with the object of measuring and recording the range of values in the weld joint (see Fig 4). For butt welds, the upper and lower rows are to transverse 2 mm maximum below the surface, depending on the plate thickness.

For each row of indentations, a minimum of 3 individual indentations is required in the weld, both sides of the HAZ and the parent metal.

For the HAZ, the indentations are to be placed as close as possible to the fusion line.

Figure 4 : Butt weld hardness indentations

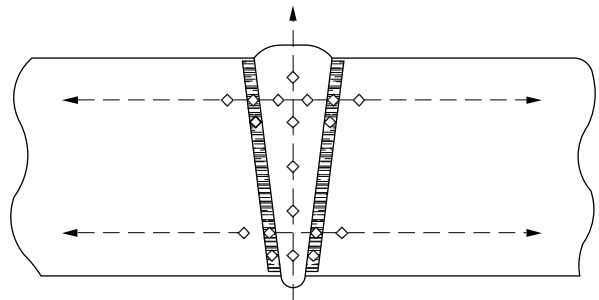

4.6.2 Where no filler metal or low hydrogen welding consumables (H5) are used in the procedure, values not higher than 380HV are considered acceptable; one individual value not higher than 400HV is accepted for each section.

Values not higher than 350HV are required in all other cases.

4.7 Metallographic examination

4.7.1 The three macro sections are to be taken as shown in Fig 2.

One section is to be a length of weld including a stop/restart position. This longitudinal section is to be cut as shown in Fig 5 and examined at the mid-thickness of the plate.

Figure 5 : Longitudinal mid-thickness macro section

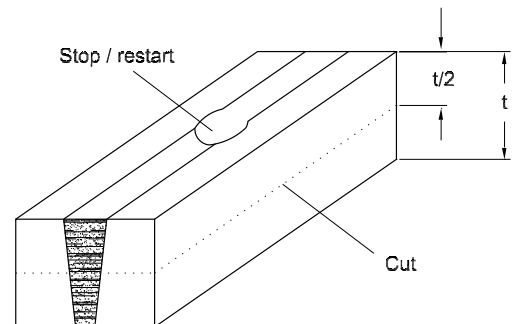

4.7.2 The test specimens are to be prepared and etched on one side only to clearly reveal the fusion line, the HAZ, the solidification structure of the weld metal and the unaffected parent metal.

4.7.3 The sections are to be examined by the naked eye (or by low power hand lens if deemed necessary) for any imperfection present in the weld metal and HAZ and for unsatisfactory profile features. Any imperfections are to be assessed in accordance with Article [3].

4.7.4 The weld shape is to be within the limits specified in Fig 6. For thicknesses up to 8 mm, lower values for "d" and "d₁" may be accepted at the discretion of *Tasneef*

Figure 6 : Weld shape limitations

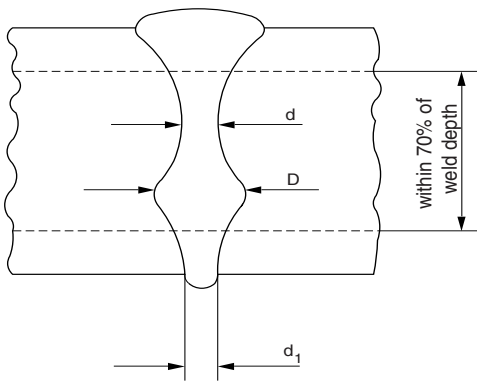

- d : Minimum weld width, with $d \geq 1,5$ mm
- d_1 : Weld root width, with $d_1 \geq 1,0$ mm
- D/d : Secondary wide zone "bulge", if bulging occurs
 $D/d \leq 1,2$

5 Fillet weld procedure test

5.1 Assembly

5.1.1 The dimensions of the T-joint fillet weld test assembly are to be in accordance with Fig 7.

The dimensions in Fig 7 are as follows:

- W min. = 300 mm
- L min. = 1000 mm
- D max. = 50 mm.

Figure 7 : T-joint test assembly

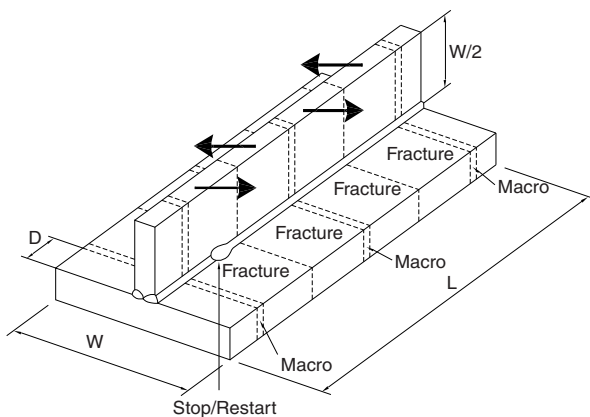

5.2 Examinations and tests

5.2.1 General

Non-destructive examinations and destructive tests are to be in accordance with the requirements of Tab 3, while the

location of the test specimens is to be in accordance with Fig 7.

Table 3 : Examinations and tests

Type of examination or test	Extent of examination or test
Visual examination	100%
Magnetic particle examination	100%
Ultrasonic examination (for full penetration welds)	100%
Macro examination	3 sections
Hardness test	3 sections
Break test	4 specimens (1)
(1) One specimen is to be taken from the stop/restart position.	

5.2.2 Non-destructive examination

The requirements in Article [3] are to be complied with. Special attention is to be paid to the stop/restart positions with respect to profile, proper fusion and absence of crater defects.

5.2.3 Macro examination

The three macro sections are to be taken as shown in Fig 7.

Two sections are to be taken from the ends adjacent to the discards, the third from the middle of the length.

5.2.4 Hardness test

Hardness indentations are to be made as shown in Fig 8 in accordance with [4.6.1], as appropriate. All hardness values are to be recorded. The values are to comply with the requirements in [4.6.2].

Figure 8 : Fillet weld hardness indentations

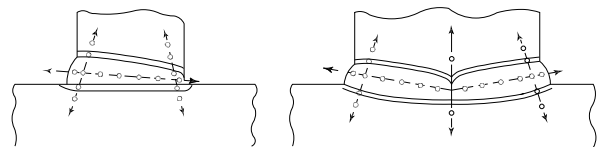

5.2.5 Break test

Break test specimens are to be taken from the length of the welded assembly remaining after removal of the macro sections. Four test specimens (not less than 100 mm each in length) are to be taken and fractured by folding the upright plate in alternate directions onto the through plate (see Fig 7).

A saw cut may be made to facilitate breaking in accordance with Fig 9.

The fracture surfaces are to be examined for possible defects which are to be assessed in accordance with Article [3].

Figure 9 : Break test

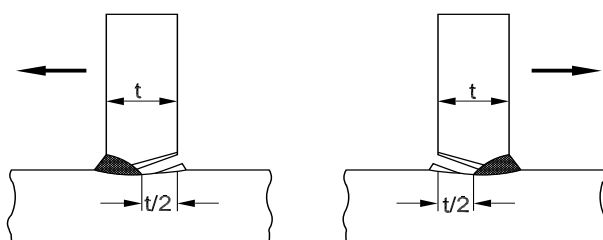

Note 1: If a break in the weld cannot be obtained, an alternative is to machine the base plate flush to the web and to radiographic the weld in the direction of weld centre line.

6 Re-testing

6.1 Non-destructive examinations

6.1.1 If the qualification assembly fails to comply with any of the requirements for visual examination or NDE, one extra assembly is to be welded and subjected to the same examination.

If this additional assembly does not comply with the relevant requirements, the welding procedure is not approved by *Tasneef* and is to be modified before further consideration is given to a new test assembly for qualification.

6.2 Destructive tests

6.2.1 Destructive test

When a destructive test (other than Charpy V for which the requirements in Sec 2, [1.7.3] apply) does not meet the requirements, two additional specimens are to be obtained for each one that failed; these tests are to be taken from the same assembly. For acceptance, both tests are to give satisfactory results.

7 Range of approval

7.1 Parent metal

7.1.1 In any steel strength categories (normal and higher), qualification of a steel of lower toughness requirements will qualify the grades of higher toughness but not vice versa, provided that the impact test temperatures used satisfy the requirements of the higher grade.

7.1.2 A change in the parent metal chemical composition (compared to those used to qualify the welding procedure) beyond the values specified in Tab 4 will require re-qualification.

A decrease in alloying content is acceptable.

7.2 Thickness

7.2.1 The approval of a procedure carried out on a welded assembly of thickness t is valid for the range $0,80t$ to t .

Speed and power may be changed within the limitations in [7.6.2].

7.3 Edge preparation and surface condition

7.3.1 Cutting process

Milled surfaces are considered the best method of edge preparation. The cutting processes are as follows:

- thermal cut
- thermal cut and sand blasted
- thermal cut and ground
- milled.

Other cutting methods, such as mechanical cutting (shearing), may be considered analogously depending on their edge geometry and surface condition. A change in the cutting process requires new qualification.

7.3.2 Surface condition

Any major change in surface condition, such as a change from uncoated to shop primer coated surfaces, requires new qualification. In this context, special attention is to be paid to T-joint configurations.

7.4 Joint type, bevel

7.4.1 Butt-joints cannot cover T-joints and vice versa.

7.4.2 Any change in joint geometry with respect to that specified in the welding procedure qualification report (WPQR) requires new qualification.

7.5 Welding procedure

7.5.1 Laser machine

A procedure approved for use on one laser machine is valid for that machine and beam shape only. The approval is valid for the focusing system used at the approval tests.

7.5.2 Modification of laser machine

Modifications carried out on an approved laser machine or the use of other laser machines having the same technical specification (from the laser beam technology point of view) only required a reduced re-approval test, if the beam parameters are within the approved range.

Table 4 : Range of qualified chemical composition

Variable	Range qualified
C	+ 0,010 %
S	+ 0,001 %
P	+ 0,001 %
S/Mn + P	+ 0,002 %
C_{EQ}	+ 0,025 %
P_{cm}	+ 0,010 %

7.6 Welding parameters

7.6.1 General

Variations within the limits described below in the welding speed, laser power, focusing parameters and wire feed rate are allowed to accommodate changes in material thickness or fit-up, without need for re-approval. Monitoring of welding parameters within a given procedure setting is to be applied.

7.6.2 Laser power and welding speed

The parameter (laser power / thickness x speed) is to be within the range 90-120% of that originally approved (while also maintaining the welding speed above 0,6m/1').

For each resetting of parameters, one test sample is to be taken and verified for weld profile shape and freedom from defects by non-destructive examination.

7.6.3 Wire feed speed

The wire feed speed is to be maintained within the limits established by the procedure tests.

7.6.4 Focusing optic and focus position

The focusing parameters are to be kept within the limits specified in accordance with recognised standards.

7.6.5 Number of runs

A change in the number of passes requires a new approval.

7.6.6 Process and shielding gas

Any change in shielding gas or plasma control gas composition requires a new approval.

A change in the flow rate up to 10% is admitted.

7.6.7 Welding position

A change of the welding position requires a new approval.

7.6.8 Welding consumables

Any change of welding consumables requires a new approval.

7.6.9 Other variables

The range of approval related to other variables may be taken according to established practice as represented in recognised standards.