



Rules for the Classification of Naval Ships

Effective from 1 July 2017

Part B

Hull and Stability

Emirates Classification Society (Tasneef)
Aldar HQ 19th Floor,
Al Raha Beach, Abu Dhabi, UAE
Abu Dhabi, United Arab Emirates

Phone (+971) 2 692 2333
Fax (+971) 2 445 433
P.O. Box. 111155
info@tasneef.ae

GENERAL CONDITIONS

Definitions:

“Administration” means the Government of the State whose flag the Ship is entitled to fly or under whose authority the Ship is authorised to operate in the specific case.

“IACS” means the International Association of Classification Societies.

“Interested Party” means the party, other than the Society, having an interest in or responsibility for the Ship, product, plant or system subject to classification or certification (such as the owner of the Ship and his representatives, the ship builder, the engine builder or the supplier of parts to be tested) who requests the Services or on whose behalf the Services are requested.

“Owner” means the registered owner, the ship owner, the manager or any other party with the responsibility, legally or contractually, to keep the ship seaworthy or in service, having particular regard to the provisions relating to the maintenance of class laid down in Part A, Chapter 2 of the Rules for the Classification of Ships or in the corresponding rules indicated in the specific Rules.

“Rules” in these General Conditions means the documents below issued by the Society:

- (i) Rules for the Classification of Ships or other special units;
- (ii) Complementary Rules containing the requirements for product, plant, system and other certification or containing the requirements for the assignment of additional class notations;
- (iii) Rules for the application of statutory rules, containing the rules to perform the duties delegated by Administrations;
- (iv) Guides to carry out particular activities connected with Services;
- (v) Any other technical document, as for example rule variations or interpretations.

“Services” means the activities described in Article 1 below, rendered by the Society upon request made by or on behalf of the Interested Party.

“Ship” means ships, boats, craft and other special units, as for example offshore structures, floating units and underwater craft.

“Society” or “TASNEEF” means Tasneef and/or all the companies in the Tasneef Group which provide the Services.

“Surveyor” means technical staff acting on behalf of the Society in performing the Services.

Article 1

1.1. The purpose of the Society is, among others, the classification and certification of ships and the certification of their parts and components. In particular, the Society:

- (i) sets forth and develops Rules;
- (ii) publishes the Register of Ships;
- (iii) issues certificates, statements and reports based on its survey activities.

1.2. The Society also takes part in the implementation of national and international rules and standards as delegated by various Governments.

1.3. The Society carries out technical assistance activities on request and provides special services outside the scope of classification, which are regulated by these general conditions, unless expressly excluded in the particular contract.

Article 2

2.1. The Rules developed by the Society reflect the level of its technical knowledge at the time they are published. Therefore, the Society, although committed also through its research and development services to continuous updating of the Rules, does not guarantee the Rules meet state-of-the-art science and technology at the time of publication or that they meet the Society's or others' subsequent technical developments.

2.2. The Interested Party is required to know the Rules on the basis of which the Services are provided. With particular reference to Classification Services, special attention is to be given to the Rules concerning class suspension, withdrawal and reinstatement. In case of doubt or inaccuracy, the Interested Party is to promptly contact the Society for clarification.

The Rules for Classification of Ships are published on the Society's website: www.tasneef.ae.

2.3. The Society exercises due care and skill:

- (i) in the selection of its Surveyors
- (ii) in the performance of its Services, taking into account the level of its technical knowledge at the time the Services are performed.

2.4. Surveys conducted by the Society include, but are not limited to, visual inspection and non-destructive testing. Unless otherwise required, surveys are conducted through sampling techniques and do not consist of comprehensive verification or monitoring of the Ship or of the items subject to certification. The surveys and checks made by the Society on board ship do not necessarily require the constant and continuous presence of the Surveyor. The Society may also commission laboratory testing, underwater inspection and other checks carried out by and under the responsibility of qualified service suppliers. Survey practices and procedures are selected by the Society based on its experience and knowledge and according to generally accepted technical standards in the sector.

Article 3

3.1. The class assigned to a Ship, like the reports, statements, certificates or any other document or information issued by the Society, reflects the opinion of the Society concerning compliance, at the time the Service is provided, of the Ship or product subject to certification, with the applicable Rules (given the intended use and within the relevant time frame).

The Society is under no obligation to make statements or provide information about elements or facts which are not part of the specific scope of the Service requested by the Interested Party or on its behalf.

3.2. No report, statement, notation on a plan, review, Certificate of Classification, document or information issued or given as part of the Services provided by the Society shall have any legal effect or implication other than a representation that, on the basis of the checks made by the Society, the Ship, structure, materials, equipment, machinery or any other item covered by such document or information meet the Rules. Any such document is issued solely for the use of the Society, its committees and clients or other duly authorised bodies and for no other purpose. Therefore, the Society cannot be held liable for any act made or document issued by other parties on the basis of the statements or information given by the Society. The validity, application, meaning and interpretation of a Certificate of Classification, or any other document or information issued by the Society in connection with its Services, is governed by the Rules of the Society, which is the sole subject entitled to make such interpretation. Any disagreement on technical matters between the Interested Party and the Surveyor in the carrying out of his functions shall be raised in writing as soon as possible with the Society, which will settle any divergence of opinion or dispute.

3.3. The classification of a Ship, or the issuance of a certificate or other document connected with classification or certification and in general with the performance of Services by the Society shall have the validity conferred upon it by the Rules of the Society at the time of the assignment of class or issuance of the certificate; in no case shall it amount to a statement or warranty of seaworthiness,

structural integrity, quality or fitness for a particular purpose or service of any Ship, structure, material, equipment or machinery inspected or tested by the Society.

3.4. Any document issued by the Society in relation to its activities reflects the condition of the Ship or the subject of certification or other activity at the time of the check.

3.5. The Rules, surveys and activities performed by the Society, reports, certificates and other documents issued by the Society are in no way intended to replace the duties and responsibilities of other parties such as Governments, designers, ship builders, manufacturers, repairers, suppliers, contractors or sub-contractors, Owners, operators, charterers, underwriters, sellers or intended buyers of a Ship or other product or system surveyed.

These documents and activities do not relieve such parties from any fulfilment, warranty, responsibility, duty or obligation (also of a contractual nature) expressed or implied or in any case incumbent on them, nor do they confer on such parties any right, claim or cause of action against the Society. With particular regard to the duties of the ship Owner, the Services undertaken by the Society do not relieve the Owner of his duty to ensure proper maintenance of the Ship and ensure seaworthiness at all times. Likewise, the Rules, surveys performed, reports, certificates and other documents issued by the Society are intended neither to guarantee the buyers of the Ship, its components or any other surveyed or certified item, nor to relieve the seller of the duties arising out of the law or the contract, regarding the quality, commercial value or characteristics of the item which is the subject of transaction.

In no case, therefore, shall the Society assume the obligations incumbent upon the above-mentioned parties, even when it is consulted in connection with matters not covered by its Rules or other documents.

In consideration of the above, the Interested Party undertakes to relieve and hold harmless the Society from any third party claim, as well as from any liability in relation to the latter concerning the Services rendered.

Insofar as they are not expressly provided for in these General Conditions, the duties and responsibilities of the Owner and Interested Parties with respect to the services rendered by the Society are described in the Rules applicable to the specific Service rendered.

Article 4

4.1. Any request for the Society's Services shall be submitted in writing and signed by or on behalf of the Interested Party. Such a request will be considered irrevocable as soon as received by the Society and shall entail acceptance by the applicant of all relevant requirements of the Rules, including these General Conditions. Upon acceptance of the written request by the Society, a contract between the Society and the Interested Party is entered into, which is regulated by the present General Conditions.

4.2. In consideration of the Services rendered by the Society, the Interested Party and the person requesting the service shall be jointly liable for the payment of the relevant fees, even if the service is not concluded for any cause not pertaining to the Society. In the latter case, the Society shall not be held liable for non-fulfilment or partial fulfilment of the Services requested. In the event of late payment, interest at the legal current rate increased by 1.5% may be demanded.

4.3. The contract for the classification of a Ship or for other Services may be terminated and any certificates revoked at the request of one of the parties, subject to at least 30 days' notice to be given in writing. Failure to pay, even in part, the fees due for Services carried out by the Society will entitle the Society to immediately terminate the contract and suspend the Services.

For every termination of the contract, the fees for the activities performed until the time of the termination shall be owed to the Society as well as the expenses incurred in view of activities already programmed; this is without prejudice to the right to compensation due to the Society as a consequence of the termination.

With particular reference to Ship classification and certification, unless decided otherwise by the Society, termination of the contract implies that the assignment of class to a Ship is withheld or, if already assigned, that it is suspended or withdrawn; any statutory certificates issued by the Society will be withdrawn in those cases where provided for by agreements between the Society and the flag State.

Article 5

5.1. In providing the Services, as well as other correlated information or advice, the Society, its Surveyors, servants or agents operate with due diligence for the proper execution of the activity. However, considering the nature of the activities performed (see art. 2.4), it is not possible to guarantee absolute accuracy, correctness and completeness of any information or advice supplied. Express and implied warranties are specifically disclaimed.

Therefore, except as provided for in paragraph 5.2 below, and also in the case of activities carried out by delegation of Governments, neither the Society nor any of its Surveyors will be liable for any loss, damage or expense of whatever nature sustained by any person, in tort or in contract, derived from carrying out the Services.

5.2. Notwithstanding the provisions in paragraph 5.1 above, should any user of the Society's Services prove that he has suffered a loss or damage due to any negligent act or omission of the Society, its Surveyors, servants or agents, then the Society will pay compensation to such person for his proved loss, up to, but not exceeding, five times the amount of the fees charged for the specific services, information or opinions from which the loss or damage derives or, if no fee has been charged, a maximum of AED5,000 (Arab Emirates Dirhams Five Thousand only). Where the fees charged are related to a number of Services, the amount of the fees will be apportioned for the purpose of the calculation of the maximum compensation, by reference to the estimated time involved in the performance of the Service from which the damage or loss derives. Any liability for indirect or consequential loss, damage or expense is specifically excluded. In any case, irrespective of the amount of the fees charged, the maximum damages payable by the Society will not be more than AED5,000,000 (Arab Emirates Dirhams Five Millions only). Payment of compensation under this paragraph will not entail any admission of responsibility and/or liability by the Society and will be made without prejudice to the disclaimer clause contained in paragraph 5.1 above.

5.3. Any claim for loss or damage of whatever nature by virtue of the provisions set forth herein shall be made to the Society in writing, within the shorter of the following periods: (i) THREE (3) MONTHS from the date on which the Services were performed, or (ii) THREE (3) MONTHS from the date on which the damage was discovered. Failure to comply with the above deadline will constitute an absolute bar to the pursuit of such a claim against the Society.

Article 6

6.1. These General Conditions shall be governed by and construed in accordance with United Arab Emirates (UAE) law, and any dispute arising from or in connection with the Rules or with the Services of the Society, including any issues concerning responsibility, liability or limitations of liability of the Society, shall be determined in accordance with UAE law. The courts of the Dubai International Financial Centre (DIFC) shall have exclusive jurisdiction in relation to any claim or dispute which may arise out of or in connection with the Rules or with the Services of the Society.

6.2. However,

- (i) In cases where neither the claim nor any counterclaim exceeds the sum of AED300,000 (Arab Emirates Dirhams Three Hundred Thousand) the dispute shall be referred to the jurisdiction of the DIFC Small Claims Tribunal; and
- (ii) for disputes concerning non-payment of the fees and/or expenses due to the Society for services, the Society shall have the

right to submit any claim to the jurisdiction of the Courts of the place where the registered or operating office of the Interested Party or of the applicant who requested the Service is located.

In the case of actions taken against the Society by a third party before a public Court, the Society shall also have the right to summon the Interested Party or the subject who requested the Service before that Court, in order to be relieved and held harmless according to art. 3.5 above.

Article 7

7.1. All plans, specifications, documents and information provided by, issued by, or made known to the Society, in connection with the performance of its Services, will be treated as confidential and will not be made available to any other party other than the Owner without authorisation of the Interested Party, except as provided for or required by any applicable international, European or domestic legislation, Charter or other IACS resolutions, or order from a competent authority. Information about the status and validity of class and statutory certificates, including transfers, changes, suspensions, withdrawals of class, recommendations/conditions of class, operating conditions or restrictions issued against classed ships and other related information, as may be required, may be published on the website or released by other means, without the prior consent of the Interested Party.

Information about the status and validity of other certificates and statements may also be published on the website or released by other means, without the prior consent of the Interested Party.

7.2. Notwithstanding the general duty of confidentiality owed by the Society to its clients in clause 7.1 above, the Society's clients hereby accept that the Society may participate in the IACS Early Warning System which requires each Classification Society to provide other involved Classification Societies with relevant technical information on serious hull structural and engineering systems failures, as defined in the IACS Early Warning System (but not including any drawings relating to the ship which may be the specific property of another party), to enable such useful information to be shared and used to facilitate the proper working of the IACS Early Warning System. The Society will provide its clients with written details of such information sent to the involved Classification Societies.

7.3. In the event of transfer of class, addition of a second class or withdrawal from a double/dual class, the Interested Party undertakes to provide or to permit the Society to provide the other Classification Society with all building plans and drawings, certificates, documents and information relevant to the classed unit, including its history file, as the other Classification Society may require for the purpose of classification in compliance with the applicable legislation and relative IACS Procedure. It is the Owner's duty to ensure that, whenever required, the consent of the builder is obtained with regard to the provision of plans and drawings to the new Society, either by way of appropriate stipulation in the building contract or by other agreement.

In the event that the ownership of the ship, product or system subject to certification is transferred to a new subject, the latter shall have the right to access all pertinent drawings, specifications, documents or information issued by the Society or which has come to the knowledge of the Society while carrying out its Services, even if related to a period prior to transfer of ownership.

Article 8

8.1. Should any part of these General Conditions be declared invalid, this will not affect the validity of the remaining provisions.

EXPLANATORY NOTE TO PART B

1. Reference edition

The reference edition for Part B is this edition effective from 1st January 2015.

2. Effective date of the requirements

2.1 All requirements in which new or amended provisions with respect to those contained in the reference edition have been introduced are followed by a date shown in brackets.

The date shown in brackets is the effective date of entry into force of the requirements as amended by last updating. The effective date of all those requirements not followed by any date shown in brackets is that of the reference edition.

2.2 Item 5 below provides a summary of the technical changes from the preceding edition.

3. Rule Variations and Corrigenda

Until the next edition of the Rules is published, Rule Variations and/or corrigenda, as necessary, will be published on the Tasneef web site (www.tasneef.ae). Except in particular cases, paper copies of Rule Variations or corrigenda are not issued.

4. Rule subdivision and cross-references

4.1 Rule subdivision

The Rules are subdivided into five parts, from A to E.

Part A: Classification and Surveys

Part B: Hull and Stability

Part C: Machinery, Systems and Fire Protection

Part D: Service Notations

Part E: Additional Class Notations

Each Part consists of:

- Chapters
- Sections and possible Appendices
- Articles
- Sub-articles
- Requirements

Figures (abbr. Fig) and Tables (abbr. Tab) are numbered in ascending order within each Section or Appendix.

4.2 Cross-references

Examples: Pt A, Ch 1, Sec 1, [3.2.1] or Pt A, Ch 1, App 1, [3.2.1]

- Pt A means Part A

The part is indicated when it is different from the part in which the cross-reference appears. Otherwise, it is not

indicated.

- Ch 1 means Chapter 1

The Chapter is indicated when it is different from the chapter in which the cross-reference appears. Otherwise, it is not indicated.

- Sec 1 means Section 1 (or App 1 means Appendix 1)

The Section (or Appendix) is indicated when it is different from the Section (or Appendix) in which the cross-reference appears. Otherwise, it is not indicated.

- [3.2.1] refers to requirement 1, within sub-article 2 of article 3.

Cross-references to an entire Part or Chapter are not abbreviated as indicated in the following examples:

- Part A for a cross-reference to Part A
- Part A, Chapter 1 for a cross-reference to Chapter 1 of Part A.

5. Summary of amendments introduced in the edition effective from 1st January 2017

This edition of the Rules for the Classification of Naval Ships contains amendments whose effective date is 1 January 2017.

The date of entry into force of each new or amended item is shown in brackets after the number of the item concerned

This edition of the Rules for the classification of Naval Ships is considered as a reference edition for future amendments.

Description of the amendments

The amendments involve both the framework of the Rules and the technical requirements.

Part B
Hull and Stability

Chapters 1 2 3 4 5 6 7 8 **9 10 11**

CHAPTER 1	GENERAL
CHAPTER 2	GENERAL ARRANGEMENT DESIGN
CHAPTER 3	STABILITY AND SEA-KEEPING
CHAPTER 4	STRUCTURE DESIGN PRINCIPLES
CHAPTER 5	DESIGN LOADS
CHAPTER 6	HULL GIRDER STRENGTH
CHAPTER 7	HULL SCANTLINGS
CHAPTER 8	OTHER STRUCTURES
CHAPTER 9	HULL OUTFITTING
CHAPTER 10	CORROSION PROTECTION AND LOADING INFORMATION
CHAPTER 11	CONSTRUCTION AND TESTING

CHAPTER 9

HULL OUTFITTING

Section 1 Rudders

1	General	11
	1.1 Application	
	1.2 Gross scantlings	
	1.3 Arrangements	
	1.4 Materials	
2	Force and torque acting on the rudder	12
	2.1 Rudder blade without cut-outs	
	2.2 Rudder blade with cut-outs (semi-spade rudders)	
3	Loads acting on the rudder structure	14
	3.1 General	
4	Rudder stock scantlings	14
	4.1 Bending moment	
	4.2 Scantlings	
5	Rudder stock couplings	16
	5.1 Horizontal flange couplings	
	5.2 Couplings between rudder stocks and tillers	
	5.3 Cone couplings between rudder stocks and rudder blades	
	5.4 Vertical flange couplings	
	5.5 Couplings by continuous rudder stock welded to the rudder blade	
	5.6 Skeg connected with rudder trunk	
6	Rudder stock and pintle bearings	20
	6.1 Forces on rudder stock and pintle bearings	
	6.2 Rudder stock bearing	
	6.3 Pintle bearings	
	6.4 Pintles	
7	Rudder blade scantlings	22
	7.1 General	
	7.2 Strength checks	
	7.3 Rudder blade plating	
	7.4 Connections of rudder blade structure with solid parts in forged or cast steel	
	7.5 Connection of the rudder blade with the rudder stock by means of horizontal flanges	
	7.6 Single plate rudders	
8	Rudder horn and solepiece scantlings	27
	8.1 General	
	8.2 Rudder horn	
	8.3 Solepieces	
9	Simplex rudder shaft	29
	9.1 Scantlings	
	9.2 Connections	

10	Steering nozzles	30
	10.1 General	
	10.2 Nozzle plating and internal diaphragms	
	10.3 Nozzle stock	
	10.4 Pintles	
	10.5 Nozzle coupling	
11	Azimuth propulsion system	32
	11.1 General	
	11.2 Arrangement	
	11.3 Design loads	
	11.4 Plating	
	11.5 Ordinary stiffeners	
	11.6 Primary supporting members	
	11.7 Hull supports of the azimuth propulsion system	

Section 2 Bulwarks and Guard Rails

1	General	35
	1.1 Introduction	
	1.2 General	
2	Bulwarks	35
	2.1 General	
	2.2 Scantlings	
3	Guard rails	36
	3.1	

Section 3 Propeller Shaft Brackets

1	General	37
	1.1 Bracket configuration	
2	Double arm propeller shaft brackets	37
	2.1 General	
	2.2 Bossed propeller shaft brackets	
	2.3 Limit state verification - loss of blade	
	2.4 Other verifications	

Section 4 Equipment

1	General	42
	1.1 General	
2	Equipment number	42
	2.1 Equipment number	
3	Equipment	45
	3.1 Shipboard fittings and supporting hull structures	
	3.2 Anchors	

- 3.3 Chain cables for anchors
- 3.4 Attachment pieces
- 3.5 Towlines and mooring lines
- 3.6 Hawse pipes
- 3.7 Windlass
- 3.8 Chain stoppers
- 3.9 Chain locker
- 3.10 Fairleads and bollards

Section 5 Masts and Other Outfitting Components

1	Masts	54
<hr/>		
	1.1 Application	
	1.2 Static analysis of masts	
	1.3 Dynamic analysis of masts	
2	Outfitting components subjected to weapon firing loads	56
<hr/>		
	2.1 General	

Appendix 1 Criteria for Direct Calculation of Rudder Loads

1	Criteria for direct calculation of the loads acting on the rudder structure	57
<hr/>		
	1.1 General	
	1.2 Data for the direct calculation	
	1.3 Force per unit length on the rudder body	
	1.4 Support spring constant	

CHAPTER 10

CORROSION PROTECTION AND LOADING INFORMATION

Section 1 Protection of Hull Metallic Structures

1	Protection by coating	63
1.1	General	
1.2	Structures to be protected	
2	Cathodic protection	63
2.1	General	
2.2	Anodes	
2.3	Impressed current systems	
3	Protection against galvanic corrosion	63
3.1	General	

Section 2 Loading Manual and Loading Instruments

1	Definitions	64
1.1	Perpendiculars	
2	Loading manual and loading instrument requirement criteria	64
2.1	General	
3	Loading manual	64
3.1	Definitions	
3.2	Conditions of approval	
4	Loading instrument	64
4.1	Definitions	
4.2	Conditions of approval	
4.3	Approval procedure	
4.4	Hull girder forces and moments	
4.5	Intact stability	
4.6	Damage stability	

CHAPTER 11

CONSTRUCTION AND TESTING

Section 1 Welding and Weld Connections

1	General	71
1.1	Application	
1.2	Base material	
1.3	Welding consumables and procedures	
1.4	Personnel and equipment	
1.5	Documentation to be submitted	
1.6	Design	
2	Type of connections and preparation	72
2.1	General	
2.2	Butt welding	
2.3	Fillet welding	
2.4	Partial and full T penetration welding	
2.5	Lap-joint welding	
2.6	Slot welding	
2.7	Plug welding	
3	Specific weld connections	80
3.1	Corner joint welding	
3.2	Bilge keel connection	
3.3	Connection between propeller post and propeller shaft bossing	
3.4	Bar stem connections	
4	Workmanship	81
4.1	Welding procedures and consumables	
4.2	Welding operations	
4.3	Crossing of structural elements	
5	Modifications and repairs during construction	82
5.1	General	
5.2	Gap and weld deformations	
5.3	Defects	
5.4	Repairs on structures already welded	
6	Inspections and checks	83
6.1	General	
6.2	Visual and non-destructive examinations	

Section 2 Special Structural Details

1	General	84
1.1	Application	
1.2	Design requirements	
1.3	Constructional requirements	
1.4	Material requirements	
1.5	Welding requirements	
1.6	Survey requirements	

2	List and characteristics of special structural details	85
2.1	General	
2.2	All types of ships with longitudinally framed sides	
2.3	Auxiliary (cargo tank regions)	

Section 3 Testing

1	General	87
1.1	Purpose and application	
1.2	Definitions	
2	Test procedures	88
2.1	General	
2.2	Structural test procedures	
2.3	Leak test procedures	
2.4	Test methods	
2.5	Application of coating	
2.6	Safe access to joints	
2.7	Hydrostatic or hydropneumatic tightness test	
2.8	Other testing methods	
2.9	Acceptance criteria for watertight doors	
3	Miscellaneous	90
3.1	Watertight decks, trunks, etc.	
3.2	Doors in bulkheads above the bulkhead deck	
3.3	Semi-watertight doors	
3.4	Steering nozzles	
4	Working tests	90
4.1	Working test of windlass	

Appendix 1 Welding Details

1	Contents	94
1.1	General	
1.2	Butt welding edge preparation	
1.3	Lap-joint, slot and plug welding	

Appendix 2 Reference Sheets for Special Structural Details

1	Contents	97
1.1	General	

Part B
Hull and Stability

Chapter 9
HULL OUTFITTING

SECTION 1	RUDDERS
SECTION 2	BULWARKS AND GUARD RAILS
SECTION 3	PROPELLER SHAFT BRACKETS
SECTION 4	EQUIPMENT
SECTION 5	MASTS AND OTHER OUTFITTING COMPONENTS
APPENDIX 1	CRITERIA FOR DIRECT CALCULATION OF RUDDER LOADS

SECTION 1 RUDDERS

Symbols

V_{AV} : maximum ahead service speed, in knots, with the ship on summer load waterline; if V_{AV} is less than 10 knots, the maximum service speed is to be taken not less than the value obtained from the following formula:

$$V_{MIN} = \frac{V_{AV} + 20}{3}$$

V_{AD} : maximum astern speed, in knots, to be taken not less than $0,5 V_{AV}$

A : total area of the rudder blade, in m^2 , bounded by the blade external contour, including the mainpiece and the part forward of the centreline of the rudder pintles, if any

k_1 : material factor, defined in [1.4.1]

k : material factor, defined in Ch 4, Sec 1, [2.3] (see also [1.4.5])

C_R : rudder force, in N, acting on the rudder blade, defined in [2.1.1] and [2.2.1]

M_{TR} : rudder torque, in N.m, acting on the rudder blade, defined in [2.1.2] and [2.2.2]

M_B : bending moment, in N.m, in the rudder stock, defined in [4.1].

1 General

1.1 Application

1.1.1 Ordinary profile rudders

The requirements of this Section apply to ordinary profile rudders, without any special arrangement for increasing the rudder force, whose maximum orientation at maximum ship speed is limited to 35° on each side.

In general, an orientation greater than 35° is accepted for manoeuvres or navigation at very low speed.

1.1.2 High lift profiles

The requirements of this Section also apply to rudders fitted with flaps to increase rudder efficiency. For these rudder types, an orientation at maximum speed less than 35° may be accepted. In these cases, the rudder forces are to be calculated by the Designer for the most severe combinations between orientation angle and ship speed. These calculations are to be considered by the Society on a case-by-case basis.

The rudder scantlings are to be designed so as to be able to sustain possible failures of the orientation control system, or, alternatively, redundancy of the system itself may be required.

1.1.3 Steering nozzles

The requirements for steering nozzles are given in [10].

1.1.4 Special rudder types

Rudders others than those in [1.1.1], [1.1.2] and [1.1.3] will be considered by the Society on a case-by-case basis.

1.2 Gross scantlings

1.2.1 With reference to Ch 4, Sec 2, [1], all scantlings and dimensions referred to in this Section are gross, i.e. they include the margins for corrosion.

1.3 Arrangements

1.3.1 Effective means are to be provided for supporting the weight of the rudder without excessive bearing pressure, e.g. by means of a rudder carrier attached to the upper part of the rudder stock. The hull structure in way of the rudder carrier is to be suitably strengthened.

1.3.2 Suitable arrangements are to be provided to prevent the rudder from lifting.

In addition, structural rudder stops of suitable strength are to be provided, except where the steering gear is provided with its own rudder stopping devices, as detailed in Pt C, Ch 1, Sec 11.

1.3.3 In rudder trunks which are open to the sea, a seal or stuffing box is to be fitted above the deepest load waterline, to prevent water from entering the steering gear compartment and the lubricant from being washed away from the rudder carrier. If the top of the rudder trunk is below the deepest waterline two separate stuffing boxes are to be provided.

1.4 Materials

1.4.1 Rudder stocks, pintles, coupling bolts, keys and cast parts of rudders are to be made of rolled steel, steel forgings or steel castings according to the applicable requirements in Part D, Chapter 2 of the Rules for the Classification of the Ships.

1.4.2 The material used for rudder stocks, pintles, keys and bolts is to have a minimum yield stress not less than 200 N/mm^2 .

1.4.3 The requirements relevant to the determination of scantlings contained in this Section apply to steels having a minimum yield stress equal to 235 N/mm^2 .

Where the material used for rudder stocks, pintles, coupling bolts, keys and cast parts of rudders has a yield stress different from 235 N/mm^2 , the scantlings calculated with the formulae contained in the requirements of this Section are to be modified, as indicated, depending on the material factor k_1 , to be obtained from the following formula:

$$k_1 = \left(\frac{235}{R_{eH}}\right)^n$$

where:

- R_{eH} : yield stress, in N/mm², of the steel used, and not exceeding the lower of 0,7 R_m and 450 N/mm²,
- R_m : minimum ultimate tensile strength, in N/mm², of the steel used,
- n : coefficient to be taken equal to:
 - $n = 0,75$ for $R_{eH} > 235$ N/mm²,
 - $n = 1,00$ for $R_{eH} \leq 235$ N/mm².

1.4.4 Significant reductions in rudder stock diameter due to the application of steels with yield stresses greater than 235 N/mm² may be accepted by the Society subject to the results of a check calculation of the rudder stock deformations.

Large rudder stock deformations are to be avoided in order to avoid excessive edge pressures in way of bearings.

1.4.5 Welded parts of rudders are to be made of approved rolled hull materials. For these members, the material factor k defined in Ch 4, Sec 1, [2.3] is to be used.

2 Force and torque acting on the rudder

2.1 Rudder blade without cut-outs

2.1.1 Rudder blade description

A rudder blade without cut-outs may have trapezoidal or rectangular contour.

2.1.2 Rudder force

The rudder force C_R is to be obtained, in N, from the following formula:

$$C_R = 132 \, n_R A V^2 r_1 r_2 r_3$$

where:

- n_R : navigation coefficient, defined in Tab 1,
- V : V_{AV} or V_{AD} , depending on the condition under consideration (for high lift profiles see [1.1.2]),
- r_1 : shape factor, to be taken equal to:

$$r_1 = \frac{\lambda + 2}{3}$$
- λ : coefficient, to be taken equal to:

$$\lambda = \frac{h^2}{A_T}$$
 and not greater than 2,
- h : mean height, in m, of the rudder area to be taken equal to (see Fig 1):

$$h = \frac{Z_3 + Z_4 - Z_2}{2}$$
- A_T : area, in m², to be calculated by adding the rudder blade area A to the area of the rudder post or rudder horn, if any, up to the height h ,
- r_2 : coefficient to be obtained from Tab 2,
- r_3 : coefficient to be taken equal to:

- $r_3 = 0,8$ for rudders outside the propeller jet (centre rudders on twin screw ships, or similar cases),
- $r_3 = 1,15$ for rudders behind a fixed propeller nozzle,
- $r_3 = 1,0$ in other cases.

Table 1 : Navigation coefficient

Navigation notation	Navigation coefficient n_R
Unrestricted navigation	1,00
Summer zone	0,95
Tropical zone	0,85
Coastal area	0,85
Sheltered area	0,75

Table 2 : Values of coefficient r_2





Rudder profile type	r_2 for ahead condition	r_2 for astern condition
NACA 00 - Goettingen 	1,10	0,80
Hollow 	1,35	0,90
Flat side 	1,10	0,90
High lift 	1,70	1,30
Fish tail 	1,40	0,80
Single plate 	1,00	1,00

Figure 1 : Geometry of rudder blade without cut-outs

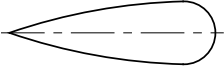

2.1.3 Rudder torque

The rudder torque M_{TR} , for both ahead and astern conditions, is to be obtained, in N.m, from the following formula:

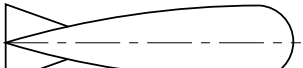
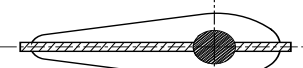
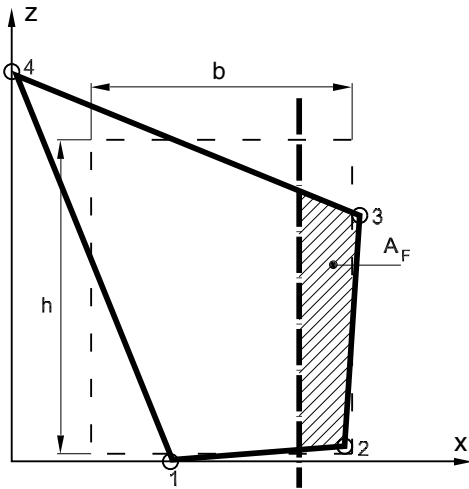
$$M_{TR} = C_R r$$

where:

r : lever of the force C_R , in m, equal to:

$$r = b \left(\alpha - \frac{A_F}{A} \right)$$

and to be taken not less than 0,1 b for the ahead condition,

b : mean breadth, in m, of rudder area to be taken equal to (see Fig 1):

$$b = \frac{x_2 + x_3 - x_1}{2}$$

α : coefficient to be taken equal to:

- $\alpha = 0,33$ for ahead condition,
- $\alpha = 0,66$ for astern condition,

A_F : area, in m^2 , of the rudder blade portion afore the centreline of rudder stock (see Fig 1).

2.2 Rudder blade with cut-outs (semi-spade rudders)

2.2.1 Rudder blade description

A rudder blade with cut-outs may have trapezoidal or rectangular contour, as indicated in Fig 2.

2.2.2 Rudder force

The rudder force C_R , in N, acting on the blade is to be calculated in accordance with [2.1.2].

2.2.3 Rudder torque

The rudder torque M_{TR} , in N.m, is to be calculated in accordance with the following procedure.

The rudder blade area A is to be divided into two rectangular or trapezoidal parts having areas A_1 and A_2 , defined in Fig 2, so that:

$$A = A_1 + A_2$$

Figure 2 : Rudder blades with cut-outs

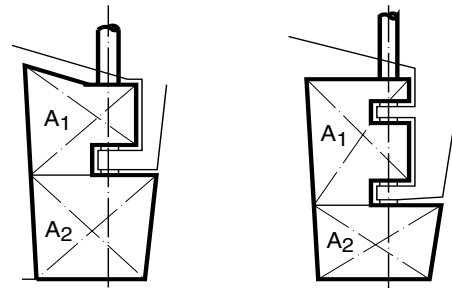

Trapezoidal rudder blade
Semi-spade rudder with
rudder horn - 2 bearings

Trapezoidal rudder blade
Semi-spade rudder with
rudder horn - 3 bearings

The rudder forces C_{R1} and C_{R2} , acting on each part A_1 and A_2 of the rudder blade, respectively, are to be obtained, in N, from the following formulae:

$$C_{R1} = C_R \frac{A_1}{A}$$

$$C_{R2} = C_R \frac{A_2}{A}$$

The levers r_1 and r_2 of the forces C_{R1} and C_{R2} , respectively, are to be obtained, in m, from the following formulae:

$$r_1 = b_1 \left(\alpha - \frac{A_{1F}}{A_1} \right)$$

$$r_2 = b_2 \left(\alpha - \frac{A_{2F}}{A_2} \right)$$

where:

b_1, b_2 : mean breadths of the rudder blade parts having areas A_1 and A_2 , respectively, to be determined according to [2.1.3],

A_{1F}, A_{2F} : areas, in m^2 , of the rudder blade parts, defined in Fig 3,

Figure 3 : Geometry of rudder blade with cut-outs

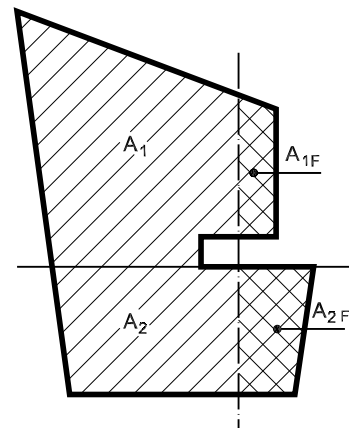

- α : coefficient to be taken equal to:
- $\alpha = 0,33$ for ahead condition,
 - $\alpha = 0,66$ for astern condition.

For rudder parts located behind a fixed structure such as a rudder horn, α is to be taken equal to:

- $\alpha = 0,25$ for ahead condition,
- $\alpha = 0,55$ for astern condition.

The torques M_{TR1} and M_{TR2} , relevant to the rudder blade parts A_1 and A_2 respectively, are to be obtained, in N.m, from the following formulae:

$$M_{TR1} = C_{R1} r_1$$

$$M_{TR2} = C_{R2} r_2$$

The total torque M_{TR} acting on the rudder stock, for both ahead and astern conditions, is to be obtained, in N.m, from the following formula:

$$M_{TR} = M_{TR1} + M_{TR2}$$

For the ahead condition only, M_{TR} is to be taken not less than the value obtained, in N.m, from the following formula:

$$M_{TR,MIN} = 0,1 C_R \frac{A_1 b_1 + A_2 b_2}{A}$$

3 Loads acting on the rudder structure

3.1 General

3.1.1 Loads

The force and torque acting on the rudder, defined in [2], induce in the rudder structure the following loads:

- bending moment and torque in the rudder stock,
- support forces,
- bending moment, shear force and torque in the rudder body,
- bending moment, shear force and torque in rudder horns and solepieces.

3.1.2 Direct load calculations

The bending moment in the rudder stock, the support forces, and the bending moment and shear force in the rudder body are to be determined through direct calculations to be performed in accordance to the static schemes and the load conditions specified in App 1.

For rudders with solepiece or rudder horns these structures are to be included in the calculation model in order to account for the elastic support of the rudder body.

The other loads (i.e. the torque in the rudder stock and in the rudder body and the loads in rudder horns and solepieces) are to be calculated as indicated in the relevant requirements of this Section.

3.1.3 Simplified methods for load calculation

For ordinary rudder types, the bending moment in the rudder stock, the support forces, and the bending moment and shear force in the rudder body may be determined through approximate methods specified in the relevant requirements of this Section.

The other loads (i.e. the torque in the rudder stock and in the rudder body and the loads in rudder horns and solepieces) are to be calculated as indicated in the relevant requirements of this Section.

4 Rudder stock scantlings

4.1 Bending moment

4.1.1 General

The bending moment M_B in the rudder stock is to be obtained as follows:

- for spade rudders M_B is to be determined according to [4.1.2] through a direct calculation,
- for 2 bearing rudders with solepiece and 2 bearing semi-spade rudders with rudder horn, M_B is to be calculated according to:
 - [4.1.2] through a direct calculation, or
 - [4.1.3] through a simplified method,
- for 3 bearing semi-spade rudders with rudder horn and for the rudder types shown in Fig 4, M_B may be taken equal to zero.

Figure 4 : Rudder types

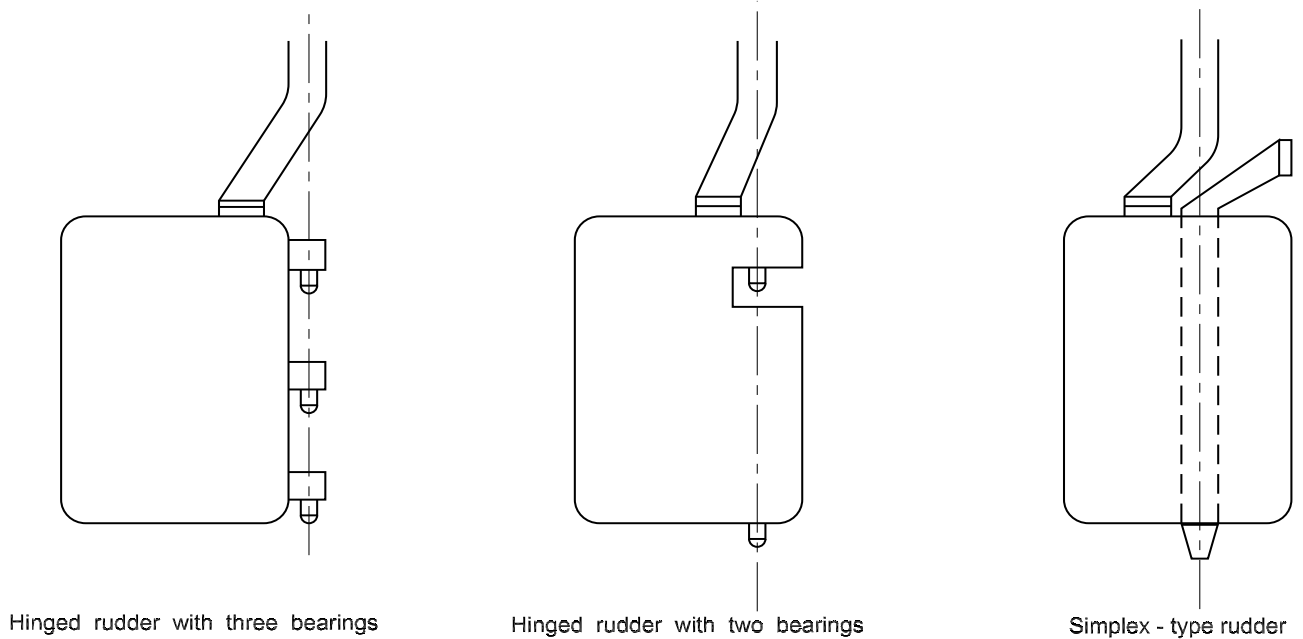

4.1.2 Bending moment calculated through a direct calculation

For spade rudders, 2 bearing rudders with solepiece and 2 bearing semi-spade rudders with rudder horn, where a direct calculation according to the static schemes and the load conditions specified in App 1 is carried out, the bending moment in the rudder stock is to be obtained as specified in App 1.

4.1.3 Bending moment calculated through a simplified method

For 2 bearing rudders with solepiece and 2 bearing semi-spade rudders with rudder horn, where a direct calculation according to the static schemes and the load conditions specified in App 1 is not carried out, the bending moment M_B in the rudder stock is to be obtained, in N.m, from the following formula:

$$M_B = 0,866 \frac{HC_R}{A}$$

where H is defined, in m^3 , in Tab 3.

4.2 Scantlings

4.2.1 Rudder stock subjected to torque only

For rudder stocks subjected to torque only (3 bearing semi-spade rudders with rudder horn in Fig 2 and the rudder types shown in Fig 4), it is to be checked that the torsional shear stress τ , in N/mm^2 , induced by the torque M_{TR} is in compliance with the following formula:

$$\tau \leq \tau_{ALL}$$

where:

τ_{ALL} : allowable torsional shear stress, in N/mm^2 :

$$\tau_{ALL} = 68/k_1$$

For this purpose, the rudder stock diameter is to be not less than the value obtained, in mm, from the following formula:

$$d_T = 4,2 (M_{TR} k_1)^{1/3}$$

4.2.2 Rudder stock subjected to combined torque and bending

For rudder stocks subjected to combined torque and bending (spade rudders, 2 bearing rudders with solepiece and 2 bearing semi-spade rudders with rudder horn in Tab 3), it is to be checked that the equivalent stress σ_E induced by the

bending moment M_B and the torque M_{TR} is in compliance with the following formula:

$$\sigma_E \leq \sigma_{E,ALL}$$

where:

σ_E : equivalent stress to be obtained, in N/mm², from the following formula:

$$\sigma_E = \sqrt{\sigma_B^2 + 3\tau_T^2}$$

σ_B : bending stress to be obtained, in N/mm², from the following formula:

$$\sigma_B = 10^3 \frac{10,2M_B}{d_{TF}^3}$$

τ_T : torsional stress to be obtained, in N/mm², from the following formula:

$$\tau_T = 10^3 \frac{5,1M_{TR}}{d_{TF}^3}$$

$\sigma_{E,ALL}$: allowable equivalent stress, in N/mm², equal to:

$$\sigma_{E,ALL} = 118/k_1 \text{ N/mm}^2$$

Table 3 : Factor H

Rudder type	H, in m ³
	<p>2 bearing rudders with solepiece</p> <p>Aa_1uH_1</p>
	<p>2 bearing semi-spade rudders with rudder horn</p> <p>$0,83 B \text{ (1)}$</p>
<p>(1) B is the greater of the absolute values obtained from the following formulae:</p> <ul style="list-style-type: none"> $B = A_1uH_1 + A_2(vH_1 + wH_2)$ $B = A_1a_2H_1 - A_2(a_3H_1 + 0,5H_2)$ <p>where a_1, a_2, a_3, u, v, w are here defined.</p>	

Table 4 : Coefficients for calculating the bending moment in the rudder stock

Coefficient	Value
a_1	$2,55 - 1,75c$
a_2	$1,75c^2 - 3,9c + 2,35$
a_3	$2,65c^2 - 5,9c + 3,25$
u	$1,1c^2 - 2,05c + 1,175$
v	$1,15c^2 - 1,85c + 1,025$
w	$-3,05c^4 + 8,14c^3 - 8,15c^2 + 3,81c - 0,735$
<p>Note 1:</p> $c = \frac{H_1}{H_1 + H_C}$ <p>H_1, H_C : as defined in Tab 3, as applicable.</p>	

For this purpose, the rudder stock diameter is to be not less than the value obtained, in mm, from the following formula:

$$d_{TF} = 4,2(M_{TR}k_1)^{1/3} \left(1 + \frac{4}{3} \left(\frac{M_B}{M_{TR}}\right)^2\right)^{1/6}$$

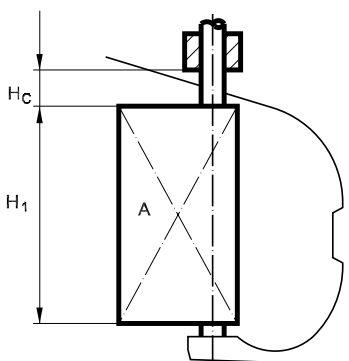
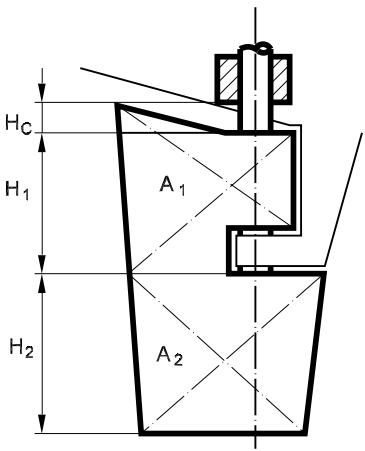
In general, the diameter of a rudder stock subjected to torque and bending may be gradually tapered above the upper stock bearing so as to reach the value of d_T in way of the quadrant or tiller.

5 Rudder stock couplings

5.1 Horizontal flange couplings

5.1.1 General

In general, the coupling flange and the rudder stock are to be forged from a solid piece. A shoulder radius as large as practicable is to be provided for between the rudder stock and the coupling flange. This radius is to be not less than $0,13 d_1$, where d_1 is the greater of the rudder stock diameters d_T and d_{TF} , in mm, to be calculated in compliance with the requirements in [4.2.1] and [4.2.2], respectively.

Where the rudder stock diameter does not exceed 350 mm, the coupling flange may be welded onto the stock provided that its thickness is increased by 10%, and that the weld extends through the full thickness of the coupling flange and that the assembly obtained is subjected to heat treatment. This heat treatment is not required if the diameter of the rudder stock is less than 75 mm.

Where the coupling flange is welded, the grade of the steel used is to be of weldable quality, particularly with a carbon content not greater than 0,25% and the welding conditions (preparation before welding, choice of electrodes, pre and post heating, inspection after welding) are to be defined to the satisfaction of the Society. The throat weld at the top of the flange is to be concave shaped to give a fillet shoulder radius as large as practicable. This radius is to be not less than $0,13 d_1$, where d_1 is defined above.

5.1.2 Bolts

Horizontal flange couplings are to be connected by fitted bolts having a diameter not less than the value obtained, in mm, from the following formula:

$$d_B = 0,62 \sqrt{\frac{d_1^3 k_{1B}}{n_B e_M k_{1S}}}$$

where:

- d_1 : rudder stock diameter, in mm, defined in [5.1.1],
- k_{1S} : material factor k_1 for the steel used for the rudder stock,
- k_{1B} : material factor k_1 for the steel used for the bolts,
- e_M : mean distance, in mm, from the bolt axes to the longitudinal axis through the coupling centre (i.e. the centre of the bolt system),
- n_B : total number of bolts, which is to be not less than 6.

Non-fitted bolts may be used provided that, in way of the mating plane of the coupling flanges, a key is fitted having a section of $(0,25d_T \times 0,10d_T)$ mm² and keyways in both the coupling flanges, and provided that at least two of the coupling bolts are fitted bolts.

The distance from the bolt axes to the external edge of the coupling flange is to be not less than $1,2 d_B$.

5.1.3 Coupling flange

The thickness of the coupling flange is to be not less than the value obtained, in mm, from the following formula:

$$t_p = d_B \sqrt{\frac{k_{1F}}{k_{1B}}}$$

where:

- d_B : bolt diameter, in mm, calculated in accordance with [5.1.2], where the number of bolts n_B is to be taken not greater than 8,
- k_{1F} : material factor k_1 for the steel used for the flange,
- k_{1B} : material factor k_1 for the steel used for the bolts.

In any case, the thickness t_p is to be not less than $0,9 d_B$.

5.1.4 Locking device

A suitable locking device is to be provided to prevent the accidental loosening of nuts.

5.2 Couplings between rudder stocks and tillers

5.2.1 Application

The requirements in Pt C, Ch 1, Sec 11 apply.

5.2.2 General

The entrance edge of the tiller bore and that of the rudder stock cone are to be rounded or bevelled.

The right fit of the tapered bearing is to be checked before final fit up, to ascertain that the actual bearing is evenly distributed and at least equal to 80% of the theoretical bearing area; push-up length is measured from the relative positioning of the two parts corresponding to this case.

The required push-up length is to be checked after releasing of hydraulic pressures applied in the hydraulic nut and in the assembly

5.2.3 Keyless couplings through special devices

The use of special devices for frictional connections, such as expandable rings, may be accepted by the Society on a case-by-case basis provided that the following conditions are complied with:

- evidence that the device is efficient (theoretical calculations and results of experimental tests, references of behaviour during service, etc.) are to be submitted to the Society
- the torque transmissible by friction is to be not less than $2 M_{TR}$
- design conditions [5.2.1]
- instructions provided by the manufacturer are to be complied with, notably concerning the pre-stressing of the tightening screws.

5.3 Cone couplings between rudder stocks and rudder blades

5.3.1 Taper on diameter

The taper on diameter of the cone couplings is to be in compliance with the following formulae:

- for cone couplings without hydraulic arrangements for assembling and disassembling the coupling:

$$\frac{1}{12} \leq \frac{d_U - d_0}{t_s} \leq \frac{1}{8}$$

- for cone couplings with hydraulic arrangements for assembling and disassembling the coupling (assembling with oil injection and hydraulic nut):

$$\frac{1}{20} \leq \frac{d_U - d_0}{t_s} \leq \frac{1}{12}$$

where:

d_U, t_s, d_0 : geometrical parameters of the coupling, defined in Fig 5.

Figure 5 : Geometry of cone coupling

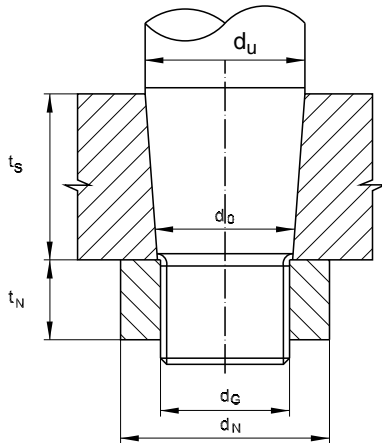

5.3.2 Push up length of cone coupling with hydraulic arrangements for assembling and disassembling the coupling

It is to be checked that the push up length Δ_E of the rudder stock tapered part into the boss is in compliance with the following formula:

$$\Delta_0 \leq \Delta_E \leq \Delta_1$$

where Δ_0 and Δ_1 are to be obtained from the formulae in Tab 5.

5.3.3 Slugging nut

The coupling is to be secured by a slugging nut, whose dimensions are to be in accordance with the following formulae:

$$t_s \geq 1,5 d_1$$

$$d_G \geq 0,65 d_1$$

$$t_N \geq 0,60 d_G$$

$$d_N \geq 1,2 d_0 \text{ and, in any case, } d_N \geq 1,5 d_G$$

where:

$t_s, d_G, t_N, d_N, d_1, d_0$: geometrical parameters of the coupling, defined in Fig 6.

The above minimum dimensions of the locking nut are only given for guidance, the determination of adequate scantlings being left to the Designer.

5.3.4 Washer

For cone couplings with hydraulic arrangements for assembling and disassembling the coupling, a washer is to be fitted between the nut and the rudder gudgeon, having a thickness not less than $0,13 d_G$ and an outer diameter not less than $0,13 d_0$ or $1,6 d_G$, whichever is the greater.

5.3.5 Key

For cone couplings without hydraulic arrangements for assembling and disassembling the coupling, a key is to be fitted having a section of $(0,25d_T \times 0,10d_T)$ mm² and keyways in both the tapered part and the rudder gudgeon.

The key is to be machined and located on the fore or aft part of the rudder. The key is to be inserted at half-thickness into stock and into the solid part of the rudder.

For cone couplings with hydraulic arrangements for assembling and disassembling the coupling, the key may be omitted. In this case the designer is to submit to the Society shrinkage calculations supplying all data necessary for the relevant check.

5.3.6 Instructions

All necessary instructions for hydraulic assembly and disassembly of the nut, including indication of the values of all relevant parameters, are to be available on board.

Table 5 : Push up length values

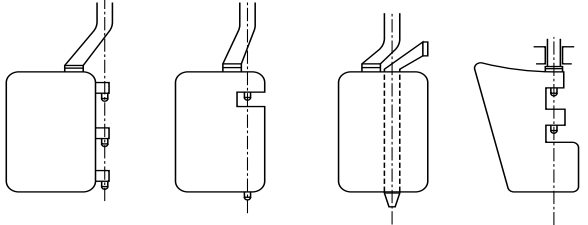
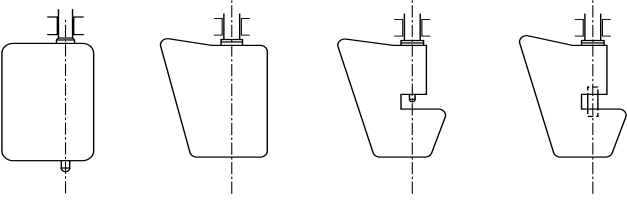
Rudder type	Δ_0	Δ_1
 <p>Hinged rudder with three bearings Hinged rudder with two bearings Simplex - type 3 bearings semi-spade rudders with rudder horn</p>	$6,2 \frac{M_{TR}\eta\gamma}{cd_M t_s \mu_A \beta} \cdot 10^{-3}$	$\frac{2\eta + 5}{1,8} \frac{\gamma d_0 R_{eH}}{10^6 c}$
 <p>Spade rudder Simple pintle Inserted pintle</p>	<p>The greater of:</p> <ul style="list-style-type: none"> $6,2 \frac{M_{TR}\eta\gamma}{cd_M t_s \mu_A \beta}$ $16 \frac{M_{TR}\eta\gamma}{ct_s^2 \beta} \sqrt{\frac{d_{1L}^6 - d_{1S}^6}{d_{1S}^6}}$ 	$\frac{2\eta + 5}{1,8} \frac{\gamma d_0 R_{eH}}{10^6 c(1 + \rho_1)}$
<p>High lift profile and special rudder types</p>	<p>The greater of:</p> <ul style="list-style-type: none"> $6,2 \frac{M_{TR}\eta\gamma}{cd_M t_s \mu_A \beta}$ $16 \frac{M_{TR}\eta\gamma}{ct_s^2 \beta} \sqrt{\frac{d_{1L}^6 - d_{1S}^6}{d_{1S}^6}}$ $6,2 \frac{M_T \eta \gamma}{cd_M t_s \mu_A \beta}$ $18,4 \frac{M_F \eta \gamma}{ct_s^2 \beta}$ 	<p>The greater of:</p> <ul style="list-style-type: none"> $\frac{2\eta + 5}{1,8} \frac{\gamma d_0 R_{eH}}{10^6 c(1 + \rho_1)}$ $\frac{2\eta + 5}{1,8} \frac{\gamma d_0 R_{eH}}{10^6 c(1 + \rho_2)}$
<p>Note 1:</p> $\rho_1 = \frac{80 \sqrt{d_{1L}^6 - d_{1S}^6}}{R_{eH} d_M t_s^2 \left[1 - \left(\frac{d_0}{d_E} \right)^2 \right]}$ $\rho_2 = \frac{7,4 M_F \cdot 10^6}{R_{eH} d_M t_s^2 \left[1 - \left(\frac{d_0}{d_E} \right)^2 \right]} \cdot 10^{-3}$ <p> R_{eH} : defined in [1.4.3] M_F, M_T : bending moment and torsional moment, respectively, in kN.m, provided by the manufacturer d_{1S} : the greater of the rudder stock diameters d_T and d_{TF}, in mm, calculated in way of the upper part of the rudder stock (at tiller level) in compliance with the requirements in [4.2.1] and [4.2.2], respectively, considering $k_1=1$ d_{1L} : the greater of the rudder stock diameters d_T and d_{TF}, in mm, calculated in way of the lower part of the rudder stock (between the top of the rudder plate and the lower bearing of the rudder stock) in compliance with the requirements in [4.2.1] and [4.2.2], respectively, considering $k_1=1$ η : coefficient to be taken equal to: $\eta = 1$ for keyed connections; $\eta = 2$ for keyless connections c : taper of conical coupling measured on diameter, to be obtained from the following formula: $c = (d_U - d_0) / t_s$ β : coefficient to be taken equal to: $\beta = 1 - (d_M / d_E)^2$ d_M : mean diameter, in mm, of the conical bore, to be obtained from the following formula: $d_M = d_U - 0,5 c t_s$ d_E : external boss diameter, in mm μ_A : coefficient to be taken equal to: $(\mu^2 - 0,25 c^2)^{1/2}$ μ, γ : coefficients to be taken equal to: <ul style="list-style-type: none"> for rudder stocks and bosses made of steel: $\mu = 0,15; \gamma = 1$ for rudder stocks made of steel and bosses made of SG iron: $\mu = 0,13; \gamma = 1,24 - 0,1 \beta$ t_s, d_U, d_0 : defined in Fig 6 </p>		

5.4 Vertical flange couplings

5.4.1 Vertical flange couplings are to be connected by fitted bolts having a diameter not less than the value obtained, in mm, from the following formula:

$$d_B = \frac{0,81 d_1}{\sqrt{n_B}} \sqrt{\frac{k_{1B}}{k_{1S}}}$$

where:

d_1 : rudder stock diameter, in mm, defined in [5.1.1],

k_{1S}, k_{1B} : material factors, defined in [5.1.2],

n_B : total number of bolts, which is to be not less than 8.

5.4.2 The first moment of area of the sectional area of bolts about the vertical axis through the centre of the coupling is to be not less than the value obtained, in cm^3 , from the following formula:

$$M_S = 0,43 d_1^3 10^{-6}$$

where:

d_1 : rudder stock diameter, in mm, defined in [5.1.1].

5.4.3 The thickness of the coupling flange, in mm, is to be not less than d_B , defined in [5.4.1].

5.4.4 The distance, in mm, from the bolt axes to the external edge of the coupling flange is to be not less than $1,2 d_B$, where d_B is defined in [5.4.1].

5.4.5 A suitable locking device is to be provided to prevent the accidental loosening of nuts.

5.5 Couplings by continuous rudder stock welded to the rudder blade

5.5.1 When the rudder stock extends through the upper plate of the rudder blade and is welded to it, the thickness of this plate in the vicinity of the rudder stock is to be not less than $0,20 d_1$, where d_1 is defined in [5.1.1].

5.5.2 The welding of the upper plate of the rudder blade with the rudder stock is to be made with a full penetration weld and is to be subjected to non-destructive inspection through dye penetrant or magnetic particle test and ultrasonic testing.

The throat weld at the top of the rudder upper plate is to be concave shaped to give a fillet shoulder radius as large as practicable. This radius is to be not less than $0,20 d_1$, where d_1 is defined in [5.1.1].

5.6 Skeg connected with rudder trunk

5.6.1 In case of a rudder trunk connected with the bottom of a skeg, the throat weld is to be concave shaped to give a fillet shoulder radius as large as practicable. This radius is considered by the Society on a case by case basis.

6 Rudder stock and pintle bearings

6.1 Forces on rudder stock and pintle bearings

6.1.1 Where a direct calculation according to the static schemes and the load conditions specified in App 1 is carried out, the support forces are to be obtained as specified in App 1.

Where such a direct calculation is not carried out, the support forces F_{A1} and F_{A2} acting on the rudder stock bearing and on the pintle bearing, respectively, are to be obtained, in N, from the following formulae:

$$F_{A1} = \left(\frac{A_{G1}}{A} + 0,87 \frac{h_0}{H_0} \right) C_R$$

$$F_{A2} = \frac{A_{G2}}{A} C_R$$

where:

A_{G1}, A_{G2} : portions of the rudder blade area A , in m^2 , supported by the rudder stock bearing and by the pintle bearing respectively, to be not less than the value obtained from Tab 5,

h_0 : coefficient defined in Tab 5,

H_0 : distance, in m, between the points at mid-height of the upper and lower rudder stock bearings.

6.2 Rudder stock bearing

6.2.1 The mean bearing pressure acting on the rudder stock bearing is to be in compliance with the following formula:

$$p_F \leq p_{F,ALL}$$

where:

p_F : mean bearing pressure acting on the rudder stock bearings, in N/mm^2 , equal to:

$$p_F = \frac{F_{A1}}{d_m h_m}$$

F_{A1} : force acting on the rudder stock bearing, in N, calculated as specified in [6.1.1],

d_m : actual inner diameter, in mm, of the rudder stock bearings,

h_m : bearing length, in mm. For the purpose of this calculation it is to be taken not greater than:

- $1,2 d_m$, for spade rudders,
 - d_m , for rudder of other types,
- where d_m is defined in [6.2.1].

$p_{F,ALL}$: allowable bearing pressure, in N/mm^2 , defined in Tab 7.

Values greater than those given in Tab 7 may be accepted by the Society on the basis of specific tests.

6.2.2 An adequate lubrication of the bearing surface is to be ensured.

Table 6 : Areas A_{G1} , A_{G2} and h_0

Rudder type	A_{G1} , in m^2	A_{G2} , in m^2	h_0 , in m
<p>spade rudders</p> 	A	0	$1,15\lambda$
<p>2 bearing rudders with solepiece</p> 	Rudder blade area above a horizontal line equally spaced from the upper and the lower edges	Rudder blade area below a horizontal line equally spaced from the upper and the lower edges	$0,3\lambda$
<p>2 bearing semi-spade rudders with rudder horn</p> 	$\frac{A_1\lambda_1h_2^2}{(h_1+h_2)^3}$	<p>The lesser of (1):</p> <ul style="list-style-type: none"> $\frac{\lambda A}{h_1+h_2}$ A 	<p>The greater of:</p> <ul style="list-style-type: none"> $0,19\frac{A_1\lambda_1}{A}$ $\left 0,3\frac{A_1\lambda_1-2A_2\lambda_2}{A}\right$
<p>3 bearing semi-spade rudders with rudder horn</p> 	0	<ul style="list-style-type: none"> lower pintle: $\frac{A_1q_1+A_2q_2}{p}$ upper pintle, the greater of: $A_1+A_2-\frac{A_1q_1+A_2q_2}{p}$ $0,5\frac{A_1q_1+A_2q_2}{p}$ 	0
<p>Hinged rudders and Simplex type rudders</p> 	0	$\frac{A}{n}$	0
<p>(1) $\lambda = \frac{(\lambda_2+h_2+h_1)A_2+\lambda_1A_1}{A}$</p> <p>Note 1: G, G_1, G_2 : centres of gravity of area A, A_1 and A_2 respectively, n : number of pintles.</p>			

Table 7 : Allowable bearing pressure

Bearing material	$p_{F,ALL}$, in N/mm ²
Lignum vitae	2,5
White metal, oil lubricated	4,5
Synthetic material with hardness between 60 and 70 Shore D (1)	5,5
Steel, bronze and hot-pressed bronze-graphite materials (2)	7,0
<p>(1) Indentation hardness test at 23°C and with 50% moisture to be performed according to a recognised standard. Type of synthetic bearing materials is to be approved by the Society.</p> <p>(2) Stainless and wear-resistant steel in combination with stock liner approved by the Society.</p>	

6.2.3 (1/1/2017)

The manufacturing tolerance t_0 on the diameter of metallic supports is to be not less than the value obtained, in mm, from the following formula:

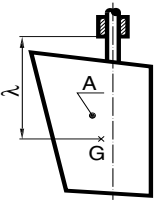
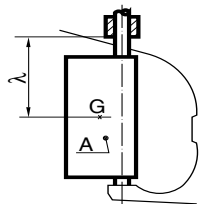
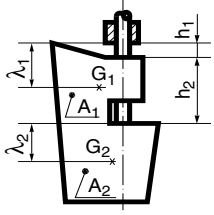
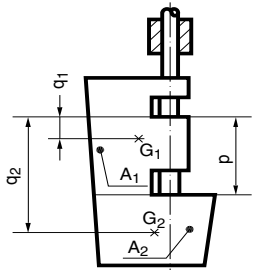
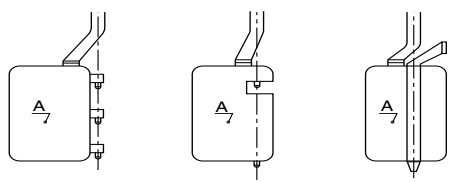
$$t_0 = \frac{d_A}{1000} + 1$$

In the case of non-metallic supports, the tolerances are to be carefully evaluated on the basis of the thermal and distortion properties of the materials employed.

The tolerance on support diameter is to be not less than 1,5 mm, unless a smaller tolerance is supported by the manufacturer's recommendation and there is documented evidence of satisfactory service history with a reduced clearance.

6.3 Pintle bearings

6.3.1 The mean bearing pressure acting on the gudgeons is to be in compliance with the following formula:

$$p_F \leq p_{F,ALL}$$

where:

p_F : mean bearing pressure acting on the gudgeons, in N/mm², equal to:

$$p_F = \frac{F_{A2}}{d_A h_L}$$

F_{A2} : force acting on the pintle, in N, calculated as specified in [6.1.1],

d_A : actual diameter, in mm, of the rudder pintles,

h_L : actual bearing length, in mm (see [6.3.3]),

$p_{F,ALL}$: allowable bearing pressure, in N/mm², defined in Tab 7.

Values greater than those given in Tab 7 may be accepted by the Society on the basis of specific tests.

6.3.2 An adequate lubrication of the bearing surface is to be ensured.

6.3.3

The bearing length, in mm, is to be not less than d_A , where d_A is defined in [6.4.1].

6.3.4 The manufacturing tolerance t_0 on the diameter of metallic supports is to be not less than the value obtained, in mm, from the following formula:

$$t_0 = \frac{d_A}{1000} + 1$$

In the case of non-metallic supports, the tolerances are to be carefully evaluated.

The tolerance on support diameter is to be not less than 1,5 mm, unless a smaller tolerance is supported by the manufacturer's recommendation and there is documented evidence of satisfactory service history with a reduced clearance.

6.4 Pintles

6.4.1 Rudder pintles are to have a diameter not less than the value obtained, in mm, from the following formula:

$$d_A = \frac{0,38 V_{AV}}{V_{AV} + 3} \sqrt{F_{A2} k_1} + f_C$$

where:

F_{A2} : force, in N, acting on the pintle, calculated as specified in [6.1.1],

f_C : coefficient depending on corrosion, whose value may generally be obtained from the following formula:

$$f_C = 30 \sqrt{k_1}$$

The Society may accept lower values of f_C , considering the ship's dimensions and satisfactory service experience of corrosion control systems adopted.

6.4.2 Provision is to be made for a suitable locking device to prevent the accidental loosening of pintles.

6.4.3 The pintles are to have a conical coupling with a taper on diameter in accordance with [5.3.1].

The conical coupling is to be secured by a nut, whose dimension are to be in accordance with [5.3.2].

6.4.4 The length of the pintle housing in the gudgeon is to be not less than the value obtained, in mm, from the following formula:

$$h_L = 0,35 \sqrt{F_{A2} k_1}$$

where:

F_{A2} : force, in N, acting on the pintle, calculated as specified in [6.1.1].

The thickness of pintle housing in the gudgeon, in mm, is to be not less than 0,25 d_A , where d_A is defined in [6.4.1].

7 Rudder blade scantlings**7.1 General****7.1.1 Application**

The requirements in [7.1] to [7.6] apply to streamlined rudders and, when applicable, to rudder blades of single plate rudders.

7.1.2 Rudder blade structure

The structure of the rudder blade is to be such that stresses are correctly transmitted to the rudder stock and pintles. To this end, horizontal and vertical web plates are to be provided.

Horizontal and vertical webs acting as main bending girders of the rudder blade are to be suitably reinforced.

7.1.3 Access openings

Streamlined rudders, including those filled with pitch, cork or foam, are to be fitted with plug-holes and the necessary devices to allow their mounting and dismounting.

Access openings to the pintles are to be provided. If necessary, the rudder blade plating is to be strengthened in way of these openings.

The corners of openings intended for the passage of the rudder horn heel and for the dismantling of pintle or stock nuts are to be rounded off with a radius as large as practicable.

Where the access to the rudder stock nut is closed with a welded plate, a full penetration weld is to be provided.

7.1.4 Connection of the rudder blade to the trailing edge for rudder blade area greater than 6 m²

Where the rudder blade area is greater than 6 m², the connection of the rudder blade plating to the trailing edge is to be made by means of a forged or cast steel fashion piece, a flat or a round bar.

7.2 Strength checks

7.2.1 Bending stresses

For the generic horizontal section of the rudder blade it is to be checked that the bending stress σ , in N/mm², induced by the loads defined in [3.1], is in compliance with the following formula:

$$\sigma \leq \sigma_{ALL}$$

where:

σ_{ALL} : allowable bending stress, in N/mm², specified in Tab 8.

Table 8 : Allowable stresses for rudder blade scantlings

Type of rudder blade	Allowable bending stress σ_{ALL} in N/mm ²	Allowable shear stress τ_{ALL} in N/mm ²	Allowable equivalent stress $\sigma_{E,ALL}$ in N/mm ²
Without cut-outs	110/k	50/k	120/k
With cut-outs (see Fig 2)	75/k	50/k	100/k

7.2.2 Shear stresses

For the generic horizontal section of the rudder blade it is to be checked that the shear stress τ , in N/mm², induced by the loads defined in [3.1], is in compliance with the following formula:

$$\tau \leq \tau_{ALL}$$

where:

τ_{ALL} : allowable shear stress, in N/mm², specified in Tab 8.

7.2.3 Combined bending and shear stresses

For the generic horizontal section of the rudder blade it is to be checked that the equivalent stress σ_E is in compliance with the following formula:

$$\sigma_E \leq \sigma_{E,ALL}$$

where:

σ_E : equivalent stress induced by the loads defined in Tab 7, to be obtained, in N/mm², from the following formula:

$$\sigma_E = \sqrt{\sigma^2 + 3\tau^2}$$

Where unusual rudder blade geometries make it practically impossible to adopt ample corner radiuses or generous tapering between the various structural elements, the equivalent stress σ_E [3.1] is to be obtained by means of direct calculations aiming at assessing the rudder blade areas where the maximum stresses, induced by the loads defined in , occur,

σ : bending stress, in N/mm²,

τ : shear stress, in N/mm²,

$\sigma_{E,ALL}$: allowable equivalent stress, in N/mm², specified in Tab 8.

7.3 Rudder blade plating

7.3.1 Plate thickness

The thickness of each rudder blade plate panel is to be not less than the value obtained, in mm, from the following formula:

$$t_F = \left(5,5s\beta \sqrt{T + \frac{C_R 10^{-4}}{A} + 2,5} \right) \sqrt{k}$$

where:

β : coefficient equal to:

$$\beta = \sqrt{1,1 - 0,5 \left(\frac{s}{b_L} \right)^2}$$

to be taken not greater than 1,0 if $b_L/s > 2,5$

s : length, in m, of the shorter side of the plate panel,

b_L : length, in m, of the longer side of the plate panel.

7.3.2 Thickness of the top and bottom plates of the rudder blade

The thickness of the top and bottom plates of the rudder blade is to be not less than the thickness t_F defined in [7.3.1], without being less than 1,2 times the thickness obtained from [7.3.1] for the attached side plating.

Where the rudder is connected to the rudder stock with a coupling flange, the thickness of the top plate which is welded in extension of the rudder flange is to be not less than 1,1 times the thickness calculated above.

7.3.3 Web spacing

The spacing between horizontal web plates is to be not greater than 1,20 m.

Vertical webs are to have spacing not greater than twice that of horizontal webs.

7.3.4 Web thickness

Web thickness is to be at least 70% of that required for rudder plating and in no case is it to be less than 8 mm, except for the upper and lower horizontal webs, for which the requirements in [7.3.2] apply.

When the design of the rudder does not incorporate a main-piece, this is to be replaced by two vertical webs closely spaced, having thickness not less than that obtained from Tab 8. In rudders having area less than 6 m², one vertical web only may be accepted provided its thickness is at least twice that of normal webs.

7.3.5 Thickness of side plating and vertical web plates welded to solid part or to rudder flange

The thickness, in mm, of the vertical web plates welded to the solid part where the rudder stock is housed, or welded to the rudder flange, as well as the thickness of the rudder side plating under this solid part, or under the rudder coupling flange, is to be not less than the value obtained, in mm, from Tab 9.

7.3.6 Reinforced strake of semi-spade rudders

A reinforced strake is to be provided in the lower pintle zone of semi-spade rudders. Its thickness is to be not less than 1,6 t_f, where t_f is defined in [7.3.1]. This strake is to be extended forward of the main vertical web plate (see Fig 6).

Figure 6 : Reinforced strake extension for semi-spade rudders

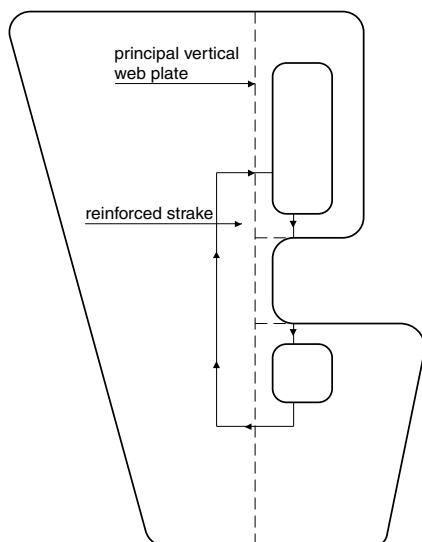

7.3.7 Main vertical webs of semi-spade rudders

The thickness of the main vertical web plate in the area between the rudder blade upper part and the pintle housing

of semi-spade rudders is to be not less than 2,6 t_f, where t_f is defined in [7.3.1].

Under the pintle housing the thickness of this web is to be not less than the value obtained from Tab 9.

Where two main vertical webs are fitted, the thicknesses of these webs are to be not less than the values obtained from Tab 8 depending on whether the web is fitted in a rudder blade area without opening or if the web is along the recess cut in the rudder for the passage of the rudder horn heel.

7.3.8 Welding

The welded connections of blade plating to vertical and horizontal webs are to be in compliance with the applicable requirements of Part D of the Rules for the Classification of the Ships.

Where the welds of the rudder blade are accessible only from outside of the rudder, slots on a flat bar welded to the webs are to be provided to support the weld root, to be cut on one side of the rudder only.

7.3.9 Rudder nose plate thickness

Rudder nose plates are to have a thickness not less than 1,25 t_f, where t_f is defined in [7.3.1].

In general this thickness need not exceed 22 mm, unless otherwise required in special cases to be considered individually by the Society.

7.4 Connections of rudder blade structure with solid parts in forged or cast steel

7.4.1 General

Solid parts in forged or cast steel which ensure the housing of the rudder stock or of the pintle are in general to be connected to the rudder structure by means of two horizontal web plates and two vertical web plates.

7.4.2 Minimum section modulus of the connection with the rudder stock housing

The section modulus of the cross-section of the structure of the rudder blade which is connected with the solid part where the rudder stock is housed, which is made by vertical web plates and rudder plating, is to be not less than that obtained, in cm³, from the following formula:

$$w_s = d_1^3 \left(\frac{H_E - H_X}{H_E} \right)^2 \frac{k}{k_1} 10^{-4}$$

where:

d₁ : rudder stock diameter, in mm, defined in [5.1.1],

H_E : vertical distance, in m, between the lower edge of the rudder blade and the upper edge of the solid part,

H_X : vertical distance, in m, between the considered cross-section and the upper edge of the solid part,

k, k₁ : material factors, defined in [1.4], for the rudder blade plating and the rudder stock, respectively.

Table 9 : Thickness of the vertical webs and rudder side plating welded to solid part or to rudder flange

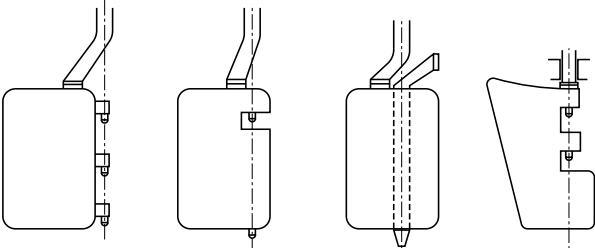
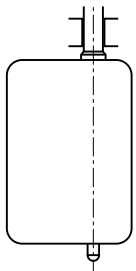
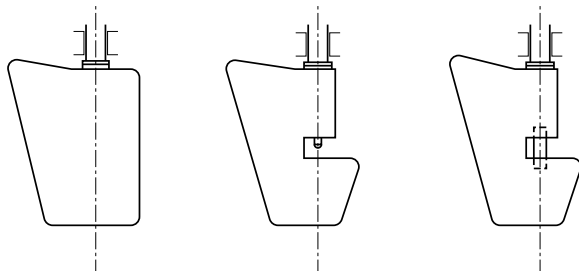
Type of rudder	Thickness of vertical web plates, in mm		Thickness of rudder plating, in mm	
	Rudder blade without opening	At opening boundary	Rudder blade without opening	Area with opening
<p>Hinged rudders, Simplex type rudders and semi-spade with three bearings rudders</p>  <p>Hinged rudder with three bearings Hinged rudder with two bearings Simplex - type 3 bearings semi-spade rudders with rudder horn</p>	t_F	$1,3 t_F$	t_F	$1,2 t_F$
<p>Rudder without intermediate pintles</p> 	$1,2 t_F$	$1,6 t_F$	$1,2 t_F$	$1,4 t_F$
<p>Spade and one bearing rudders</p>  <p>Spade rudder Simple pintle Inserted pintle</p>	$1,4 t_F$	$2,0 t_F$	$1,3 t_F$	$1,6 t_F$
<p>Note 1: t_F : defined in [7.3.1].</p>				

7.4.3 Calculation of the actual section modulus of the connection with the rudder stock housing

The actual section modulus of the cross-section of the structure of the rudder blade which is connected with the solid part where the rudder stock is housed is to be calculated with respect to the symmetrical axis of the rudder.

The breadth of the rudder plating to be considered for the calculation of this actual section modulus is to be not greater than that obtained, in m, from the following formula:

$$b = s_v + 2 \frac{H_x}{m}$$

where:

s_V : spacing, in m, between the two vertical webs (see Fig 7),
 H_x : distance defined in [7.4.2].
 m : coefficient to be taken, in general, equal to 3.

Where openings for access to the rudder stock nut are not closed by a full penetration welded plate according to [7.1.3], they are to be deducted (see Fig 7).

Figure 7 : Cross-section of the connection between rudder blade structure and rudder stock housing

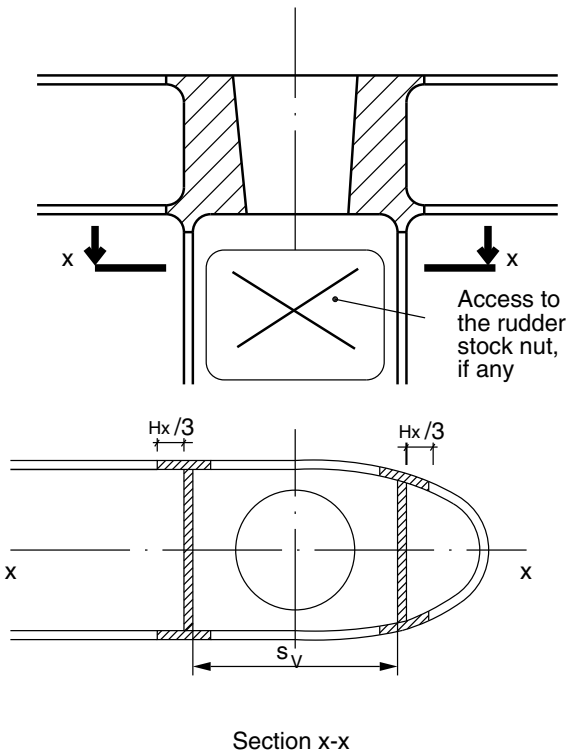

7.4.4 Thickness of horizontal web plates

In the vicinity of the solid parts, the thickness of the horizontal web plates, as well as that of the rudder blade plating between these webs, is to be not less than the greater of the values obtained, in mm, from the following formulae:

$$t_H = 1,2 t_F$$

$$t_H = 0,045 \frac{d_s^2}{s_H}$$

where:

- t_F : defined in [7.3.1],
- d_s : diameter, in mm, to be taken equal to:
 - d_1 for the solid part connected to the rudder stock,
 - d_A for the solid part connected to the pintle,
- d_1 : rudder stock diameter, in mm, defined in [5.1.1],
- d_A : pintle diameter, in mm, defined in [6.4.1],

s_H : spacing, in mm, between the two horizontal web plates.

Different thickness may be accepted when justified on the basis of direct calculations submitted to the Society for approval.

7.4.5 Thickness of side plating and vertical web plates welded to the solid part

The thickness of the vertical web plates welded to the solid part where the rudder stock is housed as well as the thickness of the rudder side plating under this solid part is to be not less than the values obtained, in mm, from Tab 9.

7.4.6 Solid part protrusions

The solid parts are to be provided with protrusions. Vertical and horizontal web plates of the rudder are to be butt welded to these protrusions.

These protrusions are not required when the web plate thickness is less than:

- 10 mm for web plates welded to the solid part on which the lower pintle of a semi-spade rudder is housed and for vertical web plates welded to the solid part of the rudder stock coupling of spade rudders,
- 20 mm for the other web plates.

7.5 Connection of the rudder blade with the rudder stock by means of horizontal flanges

7.5.1 Minimum section modulus of the connection

The section modulus of the cross-section of the structure of the rudder blade which is directly connected with the flange, which is made by vertical web plates and rudder blade plating, is to be not less than the value obtained, in cm^3 , from the following formula:

$$w_S = 1,3 d_1^3 10^{-4}$$

where d_1 is the greater of the rudder stock diameters d_T and d_{TF} , in mm, to be calculated in compliance with the requirements in [4.2.1] and [4.2.2], respectively, taken k_1 equal to 1.

7.5.2 Actual section modulus of the connection

The section modulus of the cross-section of the structure of the rudder blade which is directly connected with the flange is to be calculated with respect to the symmetrical axis of the rudder.

For the calculation of this actual section modulus, the length of the rudder cross-section equal to the length of the rudder flange is to be considered.

Where the rudder plating is provided with an opening under the rudder flange, the actual section modulus of the rudder blade is to be calculated in compliance with [7.4.3].

7.5.3 Welding of the rudder blade structure to the rudder blade flange

The welds between the rudder blade structure and the rudder blade flange are to be full penetrated (or of equivalent strength) and are to be 100% inspected by means of non-destructive tests.

Where the full penetration welds of the rudder blade are accessible only from outside of the rudder, a backing flat bar is to be provided to support the weld root.

The external fillet welds between the rudder blade plating and the rudder flange are to be of concave shape and their throat thickness is to be at least equal to 0,5 times the rudder blade thickness.

Moreover, the rudder flange is to be checked before welding by non-destructive inspection for lamination and inclusion detection in order to reduce the risk of lamellar tearing.

7.5.4 Thickness of side plating and vertical web plates welded to the rudder flange

The thickness of the vertical web plates directly welded to the rudder flange as well as the plating thickness of the rudder blade upper strake in the area of the connection with the rudder flange is to be not less than the values obtained, in mm, from Tab 9.

7.6 Single plate rudders

7.6.1 Mainpiece diameter

The mainpiece diameter is to be obtained from the formulae in [4.2].

In any case, the mainpiece diameter is to be not less than the stock diameter.

For spade rudders the lower third may taper down to 0,75 times the stock diameter.

7.6.2 Blade thickness

The blade thickness is to be not less than the value obtained, in mm, from the following formula:

$$t_B = (1,5sV_{AV} + 2,5)\sqrt{k}$$

where:

s : spacing of stiffening arms, in m, to be taken not greater than 1 m (see Fig 8).

7.6.3 Arms

The thickness of the arms is to be not less than the blade thickness.

The section modulus of the generic section is to be not less than the value obtained, in cm³, from the following formula:

$$Z_A = 0,5sC_H^2V_{AV}^2k$$

where:

C_H : horizontal distance, in m, from the aft edge of the rudder to the centreline of the rudder stock (see Fig 8),

s : defined in [7.6.2].

Figure 8 : Single plate rudder

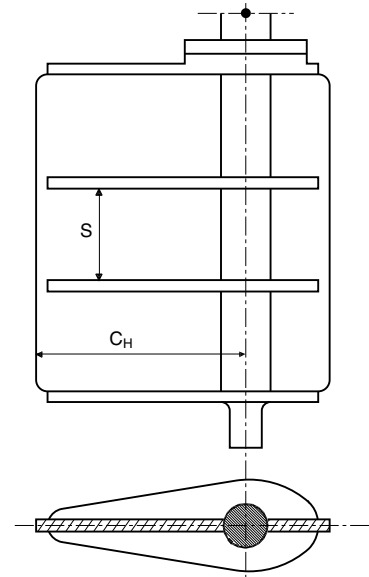

8 Rudder horn and solepiece scantlings

8.1 General

8.1.1 The weight of the rudder is normally supported by a carrier bearing inside the rudder trunk.

In the case of unbalanced rudders having more than one pintle, the weight of the rudder may be supported by a suitable disc fitted in the solepiece gudgeon.

Robust and effective structural rudder stops are to be fitted, except where adequate positive stopping arrangements are provided in the steering gear, in compliance with the applicable requirements of Pt C, Ch 1, Sec 11.

8.2 Rudder horn

8.2.1 General

When the connection between the rudder horn and the hull structure is designed as a curved transition into the hull plating, special consideration is to be paid to the effectiveness of the rudder horn plate in bending and to the stresses in the transverse web plates.

8.2.2 Loads

The following loads acting on the generic section of the rudder horn are to be considered:

- bending moment,
- shear force,
- torque.

The requirements in [8.2.3], [8.2.4] and [8.2.5] apply for calculating the above loads in the case of 2 bearing semi-spade rudders.

In the case of 3 bearing semi-spade rudders, these loads are to be calculated on the basis of the support forces at the lower and upper pintles, obtained according to [6.1].

8.2.3 Bending moment

For 2 bearing semi-spade rudders, the bending moment acting on the generic section of the rudder horn is to be obtained, in N.m, from the following formula:

$$M_H = F_{A2} z$$

where:

F_{A2} : support force, in N, to be determined through a direct calculation to be performed in accordance with the static schemes and the load conditions specified in App 1. As an alternative, it may be obtained from the following formula:

$$F_{A2} = C_R \frac{b}{l_{20} + l_{30}}$$

b, l_{20}, l_{30} : distances, in m, defined in Fig 9,

z : distance, in m, defined in Fig 10, in any case to be taken less than the distance d , in m, defined in the same figure.

Figure 9 : Geometrical parameters for the calculation of the bending moment in rudder horn

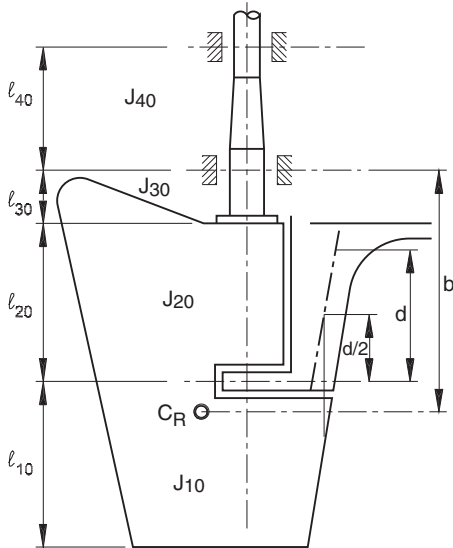
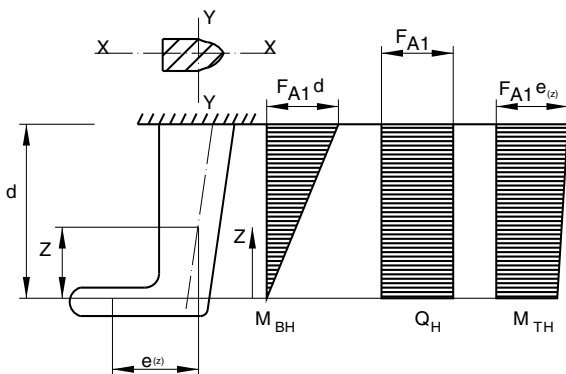

Figure 10 : Rudder horn geometry



8.2.4 Shear force

The shear force Q_H acting on the generic section of the rudder horn is to be obtained, in N, from the following formula:

$$Q_H = F_{A1}$$

where:

F_{A1} : force, in N, defined in [8.2.3].

8.2.5 Torque

The torque acting on the generic section of the rudder horn is to be obtained, in N.m, from the following formula:

$$M_T = F_{A2} e$$

where:

F_{A2} : force, in N, defined in [8.2.3],

e : distance, in m, defined in Fig 10.

8.2.6 Shear stress check

For the generic section of the rudder horn it is to be checked that:

$$\tau_s + \tau_T \leq \tau_{ALL}$$

where:

τ_s : shear stress to be obtained, in N/mm², from the following formula:

$$\tau_s = \frac{F_{A2}}{A_H}$$

F_{A2} : force, in N, defined in [8.2.3],

A_H : shear sectional area of the rudder horn in Y direction, in mm²,

τ_T : torsional stress to be obtained for hollow rudder horn, in N/mm², from the following formula:

$$\tau_T = \frac{M_T 10^3}{2 A_T t_H}$$

For solid rudder horn, τ_T is to be considered by the Society on a case-by-case basis,

M_T : torque, in N.m, defined in [8.2.5],

A_T : area of the horizontal section enclosed by the rudder horn, in mm²,

t_H : plate thickness of rudder horn, in mm,

τ_{ALL} : allowable torsional shear stress, in N/mm²:

$$\tau_{ALL} = 48/k_1$$

8.2.7 Combined stress strength check

For the generic section of the rudder horn within the length d , defined in Fig 10, it is to be checked that:

$$\sigma_E \leq \sigma_{E,ALL}$$

$$\sigma_B \leq \sigma_{B,ALL}$$

where:

σ_E : equivalent stress to be obtained, in N/mm², from the following formula:

$$\sigma_E = \sqrt{\sigma_B^2 + 3(\tau_s^2 + \tau_T^2)}$$

Where unusual rudder horn geometries make it practically impossible to adopt ample corner radiuses or generous tapering between the various structural elements, the equivalent stress σ_E is to be obtained by means of direct calculations aiming at assessing the rudder horn areas where the maximum stresses, induced by the loads defined in [3.1], occur,

σ_B : bending stress to be obtained, in N/mm², from the following formula:

$$\sigma_B = \frac{M_H}{W_X}$$

M_H : bending moment at the section considered, in N.m, defined in [8.2.3],

W_X : section modulus, in cm³, around the horizontal axis X (see Fig 10),

τ_S, τ_T : shear and torsional stresses, in N/mm², defined in [8.2.6],

$\sigma_{E,ALL}$: allowable equivalent stress, in N/mm², equal to:
 $\sigma_{E,ALL} = 120/k_1$ N/mm²

$\sigma_{B,ALL}$: allowable bending stress, in N/mm², equal to:
 $\sigma_{B,ALL} = 67/k_1$ N/mm²

8.3 Solepieces

8.3.1 Bending moment

The bending moment acting on the generic section of the solepiece is to be obtained, in N.m, from the following formula:

$$M_S = F_{A2} \times x$$

where:

F_{A2} : supporting force, in N, in the pintle bearing, to be determined through a direct calculation to be performed in accordance with the static schemes and the load conditions specified in App 1; where such a direct calculation is not carried out, this force may be taken equal to:

$$F_{A2} = \frac{C_R}{2}$$

Figure 11 : Solepiece geometry

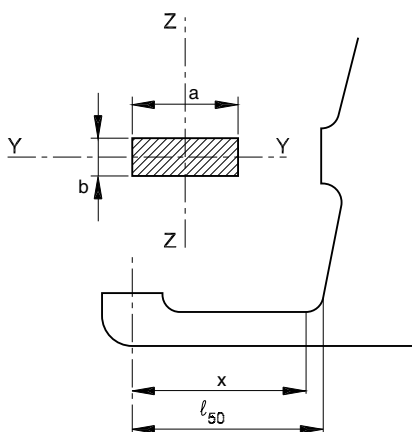

x : distance, in m, defined in Fig 11.

8.3.2 Strength checks

For the generic section of the solepiece within the length l_{50} , defined in Fig 11, it is to be checked that

$$\sigma_E \leq \sigma_{E,ALL}$$

$$\sigma_B \leq \sigma_{B,ALL}$$

$$\tau \leq \tau_{ALL}$$

where:

σ_E : equivalent stress to be obtained, in N/mm², from the following formula:

$$\sigma_E = \sqrt{\sigma_B^2 + 3\tau^2}$$

σ_B : bending stress to be obtained, in N/mm², from the following formula:

$$\sigma_B = \frac{M_S}{W_Z}$$

τ : shear stress to be obtained, in N/mm², from the following formula:

$$\tau = \frac{F_{A2}}{A_S}$$

M_S : bending moment at the section considered, in N.m, defined in [8.3.1],

F_{A2} : force, in N, defined in [8.3.1],

W_Z : section modulus, in cm³, around the vertical axis Z (see Fig 11),

A_S : shear sectional area in Y direction, in mm²,

$\sigma_{E,ALL}$: allowable equivalent stress, in N/mm², equal to:
 $\sigma_{E,ALL} = 115/k_1$ N/mm²

$\sigma_{B,ALL}$: allowable bending stress, in N/mm², equal to:
 $\sigma_{B,ALL} = 80/k_1$ N/mm²

τ_{ALL} : allowable shear stress, in N/mm², equal to:
 $\tau_{ALL} = 48/k_1$ N/mm²

8.3.3 Minimum section modulus around the horizontal axis

The section modulus around the horizontal axis Y (see Fig 11) is to be not less than the value obtained, in cm³, from the following formula:

$$W_Y = 0,5 W_Z$$

where:

W_Z : section modulus, in cm³, around the vertical axis Z (see Fig 11).

9 Simplex rudder shaft

9.1 Scantlings

9.1.1 Diameter of the rudder shaft

The rudder shaft diameter is to be not less than the value obtained, in mm, from the following formula:

$$d = 17,9 \left(\frac{\alpha A (V_{AV} + 2)^2}{\ell} \right)^{1/3}$$

where:

α : coefficient equal to:

- $\alpha = b (\ell - b + a)$ if $a \leq b$
- $\alpha = a (\ell - a + b)$ if $a > b$

a, b, ℓ : geometrical parameters, in m, defined in Fig 12.

Figure 12 : Simplex rudder shaft geometry

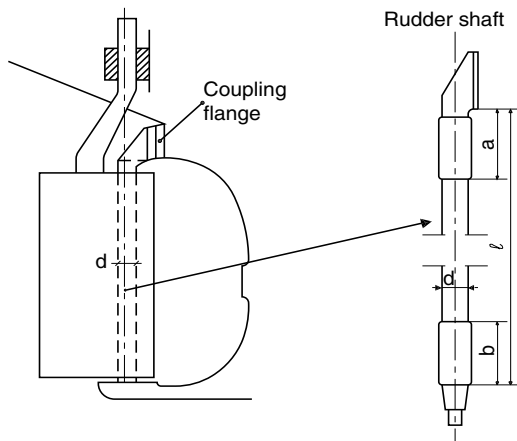

9.1.2 Sectional area of rudder shaft

The overall sectional area of the rudder shaft is to be not less than the greater of the following values:

- 70% of the sectional area for the propeller post defined in Ch 8, Sec 2, [6.3],
- value of the sectional area of the pintle supporting half the rudder blade, whose diameter is to be calculated from the formula in [6.4.1].

If the latter value is the greater, it is to be applied only where the rudder bears on the rudder shaft; in such case, it is recommended that an overthickness or a bush is provided in way of the bearing areas.

9.1.3 Bearings

The bearing length of the rudder shaft is to be not less than $1,2 d$, where d is the shaft diameter defined in [9.1.1].

The mean pressure acting on the bearings is not to exceed the relevant allowable values, defined in Tab 6 .

9.2 Connections

9.2.1 Connection with the hull

The shaft is to be connected with the hull by means of a vertical coupling flange having thickness at least equal to $d/4$, where d is the shaft diameter, obtained from the formula in [9.1.1] (see Fig 12).

The coupling flange is to be secured by means of six fitted bolts. The shank diameter of the bolts is to be not less than the coupling flange thickness defined above.

The distance from the bolt centre lines to the coupling flange edge is to be not less than 1,17 times the bolt diameter defined above.

9.2.2 Connection with the solepiece

The rudder shaft is to be connected with the solepiece by means of a cone coupling, having a taper on the radius equal to about $1/10$ and housing length not less than $1,1 d$, where d is obtained from the formula in [9.1.1] (See Fig 12).

The mean pressure exerted by the rudder shaft on the bearing is to be not greater than the relevant allowable bearing pressure, defined in Tab 6 assuming a rudder with two pintles.

10 Steering nozzles

10.1 General

10.1.1 The requirements of this Article apply to scantling steering nozzles for which the power transmitted to the propeller is less than the value obtained, in kW, from the following formula:

$$P = \frac{16900}{d_M}$$

where:

d_M : inner diameter of the nozzle, in m.

Nozzles for which the power transmitted is greater than the value obtained from the above formula are considered on a case-by-case basis.

The following requirements may apply also to fixed nozzle scantlings.

10.1.2 Nozzles normally consist of a double skin cylindrical structure stiffened by ring webs and other longitudinal webs placed perpendicular to the nozzle.

At least two ring webs are to be fitted, one of which, of greater thickness, is to be placed in way of the axis of rotation of the nozzle.

For nozzles with an inner diameter d_M exceeding 3 m, the number of ring webs is to be suitably increased.

10.1.3 Care is to be taken in the manufacture of the nozzle to ensure the welded connection between plating and webs.

10.1.4 The internal part of the nozzle is to be adequately protected against corrosion.

10.2 Nozzle plating and internal diaphragms

10.2.1 The thickness of the inner plating of the nozzle is to be not less than the value obtained, in mm, from the following formulae:

$$t_f = (0,085 \sqrt{P d_M} + 9,65) \sqrt{k} \quad \text{for } P \leq \frac{6100}{d_M}$$

$$t_f = (0,085 \sqrt{P d_M} + 11,65) \sqrt{k} \quad \text{for } P > \frac{6100}{d_M}$$

where:

P, d_M : defined in [10.1.1]

The thickness t_f is to be extended to a length, across the transverse section containing the propeller blade tips, equal to one third of the total nozzle length.

Outside this length, the thickness of the inner plating is to be not less than $(t_f - 7)$ mm and, in any case, not less than 7 mm.

10.2.2 The thickness of the outer plating of the nozzle is to be not less than $(t_f - 9)$ mm, where t_f is defined in [10.2.1] and, in any case, not less than 7 mm.

10.2.3 The thicknesses of ring webs and longitudinal webs are to be not less than $(t_f - 7)$ mm, where t_f is defined in [10.2.1], and, in any case, not less than 7 mm.

However, the thickness of the ring web, in way of the head-box and pintle support structure, is to be not less than t_F .

The Society may consider reduced thicknesses where an approved stainless steel is used, in relation to its type.

10.3 Nozzle stock

10.3.1 The diameter of the nozzle stock is to be not less than the value obtained, in mm, from the following formula:

$$d_{NTF} = 64,2 (M_T k_1)^{1/3}$$

where:

M_T : torque, to be taken as the greater of those obtained, in N.m, from the following formulae:

- $M_{TAV} = 0,3 S_{AV} a$
- $M_{TAD} = S_{AD} b$

S_{AV} : force, in N, equal to:

$$S_{AV} = 150 V_{AV}^2 A_N$$

S_{AD} : force, in N, equal to:

$$S_{AD} = 200 V_{AD}^2 A_N$$

A_N : area, in m^2 , equal to:

$$A_N = 1,35 A_{1N} + A_{2N}$$

A_{1N} : area, in m^2 , equal to:

$$A_{1N} = L_M d_M$$

A_{2N} : area, in m^2 , equal to:

$$A_{2N} = L_1 H_1$$

a, b, L_M, d_M, L_1, H_1 : geometrical parameters of the nozzle, in m, defined in Fig 13.

The diameter of the nozzle stock may be gradually tapered above the upper stock bearing so as to reach, in way of the tiller or quadrant, the value obtained, in mm, from the following formula:

$$d_{NT} = 0,75 d_{NTF}$$

Figure 13 : Geometrical parameters of the nozzle

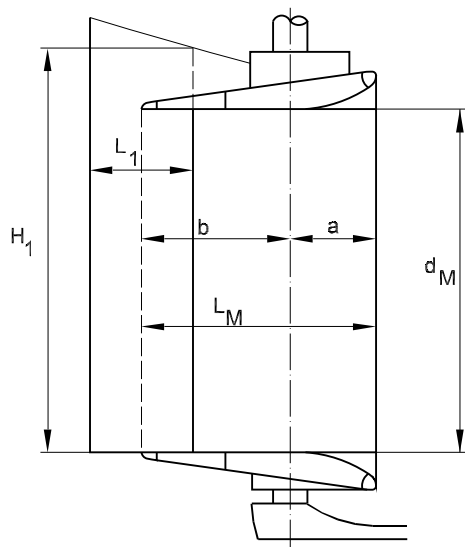

10.4 Pintles

10.4.1 The diameter of the pintles is to be not less than the value obtained, in mm, from the following formula:

$$d_A = \left(\frac{11 V_{AV}}{V_{AV} + 3} \sqrt{S_{AV} + 30} \right) \sqrt{k_1}$$

where:

S_{AV} : defined in [10.3.1].

10.4.2 The net pintle length h_A in mm, is to be not less than $1,2 d_A$ where d_A is defined in [10.4.1].

Smaller values of h_A may be accepted provided that the pressure on the gudgeon bearing p_F is in compliance with the following formula:

$$p_F \leq p_{F,ALL}$$

where:

p_F : mean bearing pressure acting on the gudgeon, to be obtained in N/mm^2 , from the following formula:

$$p_F = 10^3 \frac{0,6 S'}{d'_A h'_A}$$

S' : the greater of the values S_{AV} and S_{AD} , in kN, defined in [10.3.1],

d'_A : actual pintle diameter, in mm,

h'_A : actual bearing length of pintle, in mm,

$p_{F,ALL}$: allowable bearing pressure, in N/mm^2 , defined in Tab 6.

In any case, h_A is to be not less than d_A .

10.5 Nozzle coupling

10.5.1 Diameter of coupling bolts

The diameter of the coupling bolts is to be not less than the value obtained, in mm, from the following formula:

$$d_B = 0,23 d_{NTF} \sqrt{\frac{k_{1B}}{k_{1A}}}$$

where:

d_{NTF} : diameter of the nozzle stock, in mm, defined in [10.3.1],

k_{1A} : material factor k_1 for the steel used for the stock,

k_{1B} : material factor k_1 for the steel used for the bolts.

Non-fitted bolts may be used provided that, in way of the mating plane of the coupling flanges, a key is fitted having a section of $(0,25 d_{NT} \times 0,10 d_{NT}) mm^2$, where d_{NT} is defined in [10.3.1], and keyways in both the coupling flanges, and provided that at least two of the coupling bolts are fitted bolts.

The distance from the bolt axes to the external edge of the coupling flange is to be not less than $1,2 d_B$.

10.5.2 Thickness of coupling flange

The thickness of the coupling flange is to be not less than the value obtained, in mm, from the following formula:

$$t_P = d_{NTF} \sqrt{\frac{k_{1F}}{k_{1B}}}$$

where:

d_{NTF} : diameter of the nozzle stock, in mm, defined in [10.3.1],

k_{1B} : material factor k_1 for the steel used for the bolts,

k_{1F} : material factor k_1 for the steel used for the coupling flange.

10.5.3 Push up length of cone couplings with hydraulic arrangements for assembling and disassembling the coupling

It is to be checked that the push up length Δ_E of the nozzle stock tapered part into the boss is in compliance with the following formula:

$$\Delta_0 \leq \Delta_E \leq \Delta_1$$

where:

Δ_0 : the greater of:

- $6, 2 \frac{M_{TR} \eta \gamma}{c d_M t_s \mu_A \beta}$
- $16 \frac{M_{TR} \eta \gamma}{c t_s^2 \beta} \sqrt{\frac{d_{NTF}^6 - d_{NT}^6}{d_{NT}^6}}$

$$\Delta_1 = \frac{2\eta + 5}{1,8} \frac{\gamma d_0 R_{eH}}{10^6 c (1 + \rho_1)}$$

$$\rho_1 = \frac{80 \sqrt{d_{NTF}^6 - d_{NT}^6}}{R_{eH} d_M t_s^2 \left[1 - \left(\frac{d_0}{d_{NTF}} \right)^2 \right]}$$

d_{NTF} : nozzle stock diameter, in mm, to be obtained from the formula in [10.3.1], considering $k_1=1$

d_{NT} : nozzle stock diameter, in mm, to be obtained from the formula in [10.3.1], considering $k_1=1$

$\eta, c, \beta, d_M, d_E, \mu_A, \mu, \gamma$: defined in Tab 5

t_s, d_U, d_0 : defined in Fig 6

R_{eH} : defined in [1.4.3].

10.5.4 Locking device

A suitable locking device is to be provided to prevent the accidental loosening of nuts.

11 Azimuth propulsion system

11.1 General

11.1.1 Arrangement

The azimuth propulsion system is constituted by the following sub-systems (see Fig 14):

- the steering unit,
- the bearing,
- the hull supports,
- the rudder part of the system,
- the pod, which contains the electric motor in the case of a podded propulsion system.

Figure 14 : Azimuth propulsion system

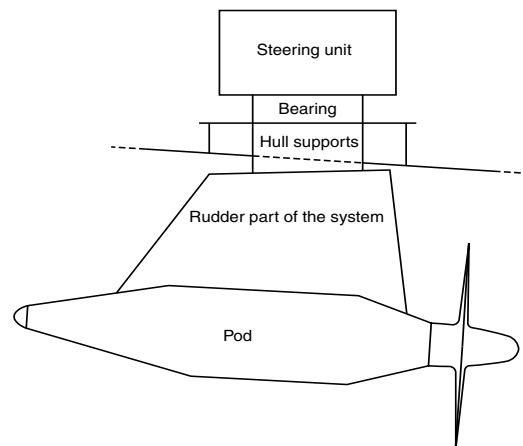

11.1.2 Application

The requirements of this Article apply to the scantlings of the hull supports, the rudder part and the pod.

The steering unit and the bearing are to comply with the requirements in Pt C, Ch 1, Sec 11 and Pt C, Ch 1, Sec 12, respectively.

11.1.3 Operating conditions

The maximum angle at which the azimuth propulsion system can be oriented on each side when the ship navigates at its maximum speed is to be specified by the Designer. Such maximum angle is generally to be less than 35° on each side.

In general, orientations greater than this maximum angle may be considered by the Society for azimuth propulsion systems during manoeuvres, provided that the orientation values together with the relevant speed values are submitted to the Society for approval.

11.2 Arrangement

11.2.1 Plans to be submitted

In addition to the plans showing the structural arrangement of the pod and the rudder part of the system, the plans showing the arrangement of the azimuth propulsion system supports are to be submitted to the Society for approval. The scantlings of the supports and the maximum loads which acts on the supports are to be specified in these drawings.

11.2.2 Locking device

The azimuth propulsion system is to be mechanically lockable in a fixed position, in order to avoid rotations of the system and propulsion in undesirable directions in the event of damage.

11.3 Design loads

11.3.1 The lateral pressure to be considered for scantling of plating and ordinary stiffeners of the azimuth propulsion system is to be determined for an orientation of the system equal to the maximum angle at which the azimuth propulsion system can be oriented on each side when the ship navigates at its maximum speed.

The total force which acts on the azimuth propulsion system is to be obtained by integrating the lateral pressure on the external surface of the system.

The calculations of lateral pressure and total force are to be submitted to the Society for information.

11.4 Plating

11.4.1 Plating of the rudder part of the azimuth propulsion system

The thickness of plating of the rudder part of the azimuth propulsion system is to be not less than that obtained, in mm, from the formulae in [7.3.1], in which the term C_R/A is to be replaced by the lateral pressure calculated according to [11.3].

11.4.2 Plating of the pod

The thickness of plating of the pod is to be not less than that obtained, in mm, from the formulae in Ch 7, Sec 1, where the lateral pressure is to be calculated according to [11.3].

11.4.3 Webs

The thickness of webs of the rudder part of the azimuth propulsion system is to be determined according to [7.3.4], where the lateral pressure is to be calculated according to [11.3].

11.5 Ordinary stiffeners

11.5.1 Ordinary stiffeners of the pod

The scantlings of ordinary stiffeners of the pod are to be not less than those obtained from the formulae in Ch 7, Sec 2, where the lateral pressure is to be calculated according to [11.3].

11.6 Primary supporting members

11.6.1 Analysis criteria

The scantlings of primary supporting members of the azimuth propulsion system are to be obtained through direct calculations, to be carried out according to the following requirements:

- the structural model is to include the pod, the rudder part of the azimuth propulsion system, the bearing and the hull supports,
- the boundary conditions are to represent the connections of the azimuth propulsion system to the hull structures,
- the loads to be applied are those defined in [11.6.2].

The direct calculation analyses (structural model, load and stress calculation, strength checks) carried out by the Designer are to be submitted to the Society for information.

11.6.2 Loads

The following loads are to be considered in the direct calculation of the primary supporting members of the azimuth propulsion system:

- gravity loads,
- buoyancy,
- maximum loads calculated for an orientation of the system equal to the maximum angle at which the azimuth propulsion system can be oriented on each side when the ship navigates at its maximum speed,
- maximum loads calculated for the possible orientations of the system greater than the maximum angle at the relevant speed (see [11.1.3]),
- maximum loads calculated for the crash stop of the ship obtained through inversion of the propeller rotation,
- maximum loads calculated for the crash stop of the ship obtained through a 180° rotation of the pod.

11.6.3 Strength check

It is to be checked that the Von Mises equivalent stress σ_E in primary supporting members, calculated, in N/mm², for the load cases defined in [11.6.2], is in compliance with the following formula:

$$\sigma_E \leq \sigma_{ALL}$$

where:

σ_{ALL} : allowable stress, in N/mm², to be taken equal to the lesser of the following values:

- 0,275 R_m
- 0,55 R_{eH}

R_m : tensile strength, in N/mm², of the material, defined in Ch 4, Sec 1, [2],

R_{eH} : minimum yield stress, in N/mm², of the material, defined in Ch 4, Sec 1, [2].

11.7 Hull supports of the azimuth propulsion system

11.7.1 Analysis criteria

The scantlings of hull supports of the azimuth propulsion system are to be obtained through direct calculations, to be carried out in accordance with the requirements in [11.6.1].

11.7.2 Loads

The loads to be considered in the direct calculation of the hull supports of the azimuth propulsion system are those specified in [11.6.2].

11.7.3 Strength check

It is to be checked that the Von Mises equivalent stress σ_E in hull supports, in N/mm², calculated for the load cases defined in [11.6.2], is in compliance with the following formula:

$$\sigma_E \leq \sigma_{ALL}$$

where:

σ_{ALL} : allowable stress, in N/mm², equal to:

$$\sigma_{ALL} = 65/k$$

k : material factor, defined in Ch 4, Sec 1, [2.3].

Values of σ_E greater than σ_{ALL} may be accepted by the Society on a case-by-case basis, depending on the localisation of σ_E and on the type of direct calculation analysis.

SECTION 2

BULWARKS AND GUARD RAILS

1 General

1.1 Introduction

1.1.1

The requirements of this Section apply to the arrangement of bulwarks and guard rails provided at boundaries of the main deck, superstructure decks and tops of the first tier of deckhouses located on the main deck.

1.2 General

1.2.1

Efficient bulwarks or guard rails are to be fitted at the boundaries of all exposed parts of the main deck and superstructure decks directly attached to the main deck, as well as the first tier of deckhouses fitted on the main deck and the superstructure ends.

1.2.2 The height of the bulwarks or guard rails is to be at least 1 m from the deck. However, where their height would interfere with the normal operation of the ship, a lesser height may be accepted, if adequate protection is provided.

1.2.3

Where superstructures are connected by trunks, open rails are to be fitted for the whole length of the exposed parts of the main deck.

1.2.4

Open rails on the weather parts of the main deck for at least half the length of the exposed parts are to be fitted.

Alternatively, freeing ports complying with Ch 8, Sec 9, [5] are to be fitted.

1.2.5

In ships with bulwarks and trunks of breadth not less than $0,6 B$, which are included in the calculation of damage stability, open rails on the weather parts of the main deck in way of the trunk for at least half the length of the exposed parts are to be fitted.

Alternatively, freeing ports complying with Ch 8, Sec 9, [4.3.1] are to be fitted.

1.2.6 In ships having superstructures which are open at either or both ends, adequate provision for freeing the space within such superstructures is to be provided.

1.2.7 The freeing port area in the lower part of the bulwarks is to be in compliance with the applicable requirements of Ch 8, Sec 9, [5].

2 Bulwarks

2.1 General

2.1.1 As a rule, plate bulwarks are to be stiffened at the upper edge by a suitable bar and supported either by stays or plate brackets spaced not more than 2,0 m apart.

Bulwarks are to be aligned with the beams located below or are to be connected to them by means of local transverse stiffeners.

As an alternative, the lower end of the stay may be supported by a longitudinal stiffener.

2.1.2

The spacing forward of $0,07 L$ from the fore end of brackets and stays is to be not greater than 1,2 m.

2.1.3 Where bulwarks are cut completely, the scantlings of stays or brackets are to be increased with respect to those given in [2.2].

2.1.4 As a rule, bulwarks are not to be connected either to the upper edge of the sheerstrake plate or to the stringer plate.

Failing this, the detail of the connection will be examined by the Society on a case-by-case basis.

2.2 Scantlings

2.2.1 The thickness of bulwarks on the main deck not exceeding 1100 mm in height is to be not less than:

- 5,5 mm for $L \leq 30$ m,
- 6,0 mm for $30 < L \leq 120$ m,
- 6,5 mm for $120 < L \leq 150$ m,
- 7,0 mm for $L > 150$ m.

Where the height of the bulwark is equal to or greater than 1800 mm, its thickness is to be equal to that calculated for the side of a superstructure situated in the same location as the bulwark.

For bulwarks between 1100 mm and 1800 mm in height, their thickness is to be calculated by linear interpolation.

2.2.2 Bulwark plating and stays are to be adequately strengthened in way of eyeplates used for shrouds or other tackles in use for cargo gear operation, as well as in way of hawserholes or fairleads provided for mooring or towing.

2.2.3 At the ends of partial superstructures and for the distance over which their side plating is tapered into the bulwark, the latter is to have the same thickness as the side plating; where openings are cut in the bulwark at these positions, adequate compensation is to be provided either by increasing the thickness of the plating or by other suitable means.

2.2.4 The section modulus of stays in way of the lower part of the bulwark is to be not less than the value obtained, in cm^3 , from the following formula:

$$Z = 40 s (1 + 0,01 L) h_B^2$$

where:

- L : length of ship, in m, to be assumed not greater than 100 m,
s : spacing of stays, in m,
h_B : height of bulwark, in m, measured between its upper edge and the deck.

The actual section of the connection between stays and deck structures is to be taken into account when calculating the above section modulus.

To this end, the bulb or face plate of the stay may be taken into account only where welded to the deck; in this case the beam located below is to be connected by double continuous welding.

For stays with strengthening members not connected to the deck, the calculation of the required minimum section modulus is considered by the Society on a case-by-case basis.

At the ends of the ship, where the bulwark is connected to the sheerstrake, an attached plating having width not exceeding 600 mm may also be included in the calculation of the actual section modulus of stays.

2.2.5 Openings in bulwarks are to be arranged so that the protection of the crew is to be at least equivalent to that provided by the horizontal courses in [3.1.2].

For this purpose, vertical rails or bars spaced approximately 230 mm apart may be accepted in lieu of rails or bars arranged horizontally.

3 Guard rails

3.1

3.1.1 Where guard rails are provided, the upper edge of sheerstrake is to be kept as low as possible.

3.1.2 The opening below the lowest course is to be not more than 230 mm. The other courses are to be not more than 380 mm apart.

3.1.3 In the case of ships with rounded gunwales or sheerstrake, the stanchions are to be placed on the flat part of the deck.

3.1.4 Fixed, removable or hinged stanchions are to be fitted about 1,5 m apart. At least every third stanchion is to be supported by a bracket or stay.

Removable or hinged stanchions are to be capable of being locked in the upright position.

3.1.5 Wire ropes may only be accepted in lieu of guard rails in special circumstances and then only in limited lengths. Wires are to be made taut by means of turnbuckles.

3.1.6 Chains may only be accepted in short lengths in lieu of guard rails if they are fitted between two fixed stanchions and/or bulwarks.

SECTION 3

PROPELLER SHAFT BRACKETS

Symbols

- θ : defined in Fig 1 and Fig 2,
 D_e : propeller diameter, in m,
 L : length of bracket, in m,
 A : cross sectional area of bracket, in m².

$$K_6 = \frac{2 - \frac{1}{L_1} - \frac{1}{L_1^2}}{4 \left(1 + \frac{1}{L_1} + \frac{1}{L_1^2} \right)}$$

where:

- L_1 : length, in m, of bracket between the hull and the intersection point with the propeller bossing, obtained as $L_1 = (L - l)$, both defined in Fig 1 and Fig 2,
 l : distance, in m, from above point to the intersection between the barycentre axis of the brackets, defined in Fig 1 and Fig 2.

1 General

1.1 Bracket configuration

1.1.1 (1/1/2017)

Propeller shafting are generally supported by two brackets, a main one connected to the propeller bossing and an intermediate one between this one and the ship's hull.

2 Double arm propeller shaft brackets

2.1 General

2.1.1 (1/1/2017)

This type of propeller shaft bracket consists of two arms arranged at right angles and converging in the propeller shaft bossing.

Single arm propeller shaft brackets are generally to be avoided.

Exceptions to this will be considered by the Society on a case-by-case basis.

Double arm propeller shaft brackets may be radial or tangential, as schematically shown in Fig 1 and Fig 2, respectively.

Usually, the vertical plane passing through the base chord of the bracket is parallel to the ship's symmetry plane. When this is not the case the brackets are said to be twisted and the angle of twist must be identified. See Fig 3.

The brackets should be in a lateral plane. However, when more space is needed between the brackets and the propeller,

or when brackets normal to the hull are considered, the brackets inclination angle must be towards the aft. See Fig 4.

2.1.2 The hull structure in the zone where the propeller brackets are attached to the hull must be capable of completely absorbing the forces induced by the brackets; in particular the connection with primary longitudinal structural members is important. The connections between brackets-hull and brackets-propeller bossing are to be rounded.

2.1.3 The lowest natural frequency of the brackets should exceed the blade frequency with not less than 20%.

In cases where this is not possible, the above requirement should be fulfilled for the second resonance frequency and furthermore the blade frequency should be at least twice the lowest natural frequency.

Figure 1 : Radial type double arm propeller bracket

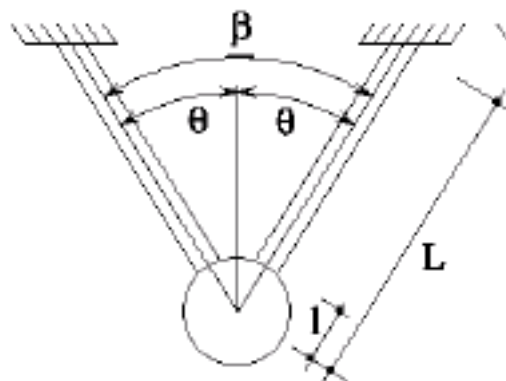

Figure 2 : Tangential type double arm propeller bracket

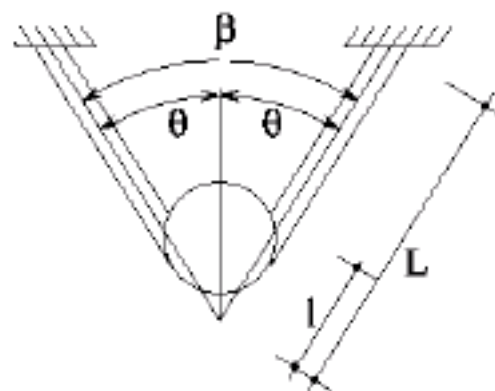

Figure 3 : Twist of the propeller bracket

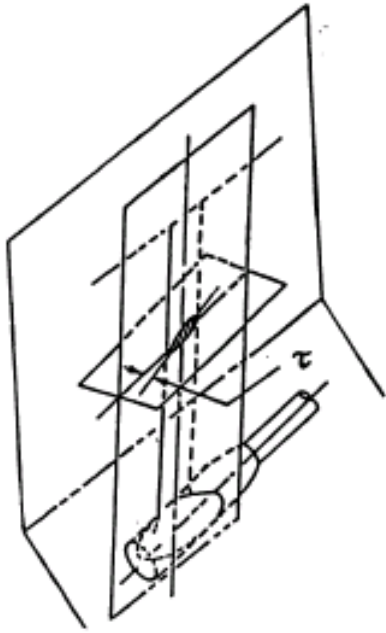
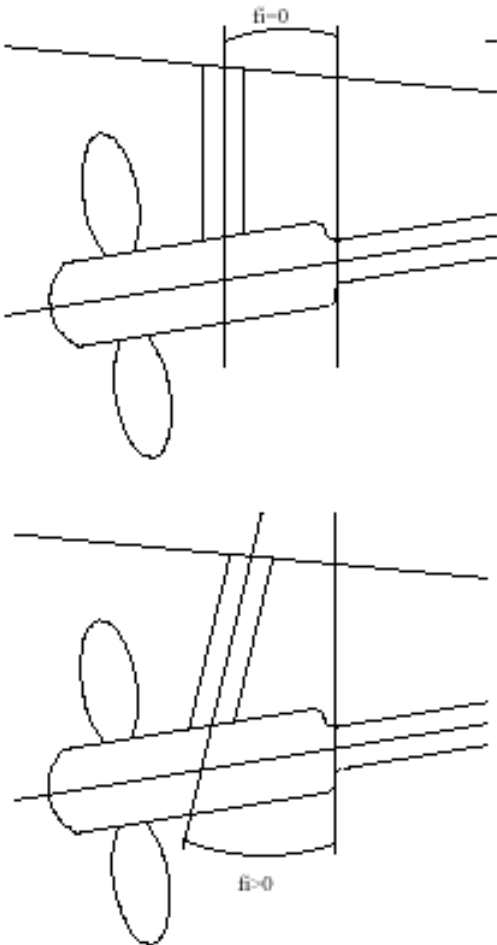

Figure 4 : Vertical inclination of the propeller bracket



2.1.4 Scantlings of elliptical arm (1/1/2017)

Cast or forged propeller shaft brackets having arms of elliptical section are to have a minor axis d_1 and a major axis d_2 , in mm, not less than those obtained from the following formulae:

$$d_1 = 0,4 d_p$$

$$d_2 = 0,01 \left(\frac{d_p}{d_1} \right)^3$$

where:

- ℓ_B : length of the longer arm, in mm, measured from the section at the root of the palm to that at the root of the boss,
- d_p : propeller shaft diameter, in mm, measured inside the liner, if any.

2.1.5 Minimum inertia of arm section (1/1/2017)

In the case of arms of other shapes, the inertia of the cross-section about its major axis is to be not less than the value obtained, in cm^4 , from the following formula:

$$J = 0,5 \ell_B d_p^3 10^{-7}$$

where:

- ℓ_B, d_p : defined in [2.1.4].

2.1.6 Scantlings of propeller shaft bossing (1/1/2017)

The length of the propeller shaft bossing is to be not less than the length of the aft sterntube bearing bushes.

The thickness of the propeller shaft bossing is to be not less than $0,33 d_p$.

2.1.7 Bracket arm attachments (1/1/2017)

In way of bracket arms attachments, the thickness of deep floors or girders is to be suitably increased. Moreover, the shell plating is to be increased in thickness and suitably stiffened.

2.2 Bossed propeller shaft brackets

2.2.1 General (1/1/2017)

Bossed propeller shaft brackets consist of a U-shaped cast steel arm connected to the hull by means of a substantial palm and ending in a boss for propeller shaft support.

2.2.2 Minimum modulus of arm section (1/1/2017)

The section modulus at the root of the arm calculated about the horizontal neutral axis of the root section is to be not less than the value obtained, in cm^3 , from the following formula:

$$Z = 75 \ell_B d_p^2 10^{-7}$$

where:

- ℓ_B, d_p : defined in [2.1.4].

2.2.3 Scantling of the boss (1/1/2017)

The length of the boss, in mm, is to be greater than $2,3 d_p$, where d_p is defined in [2.1.4]. In any case, it is to be less than $3 d_p$.

The thickness of the boss, in mm, is to be not less than $0,33 d_p$.

The aft end of the bossing is to be adequately supported.

2.2.4 Scantling of the end supports (1/1/2017)

The scantlings of end supports are to be specially considered. Supports are to be adequately designed to transmit the loads to the main structure.

End supports are to be connected to at least two deep floors of increased thickness or connected to each other within the ship.

2.2.5 Stiffening of the boss plating (1/1/2017)

Stiffening of the boss plating is to be specially considered. At the aft end, transverse diaphragms are to be fitted at every frame and connected to floors of increased scantlings.

At the fore end, web frames spaced not more than four frames apart are to be fitted.

2.3 Limit state verification - loss of blade

2.3.1 General

In the case of loss of a propeller blade it is to be verified that the maximum global stress σ_{TOT} induced in the propeller brackets do not exceed the permissible stress σ_p

$$\sigma_{TOT} \leq \sigma_p$$

where the permissible stress is defined as:

$$\sigma_p = 0,48\sigma_y$$

where:

σ_y : is the yield stress of the material.

2.3.2 Maximum global stress

The maximum global stress acting on the propeller shaft bracket is to be determined as the sum of the maximum bending induced stress and the compressive stress at that instant:

$$\sigma_{TOT} = \sigma_c + \sigma_x$$

where:

σ_c : compressive stress when bending stress is maximised, defined in [2.3.4]

σ_x : the largest bending stress between σ_A and σ_B , defined in [2.3.3].

2.3.3 Acting bending stresses

As the brackets are subjected to combined bending (longitudinal and transversal) the stress can achieve its largest values at two locations; A and B, see Fig 5.

The stress must therefore be determined at both these locations, and the acting stress σ_x is then taken as the largest of these.

Figure 5 : Locations of max stress under combined bending

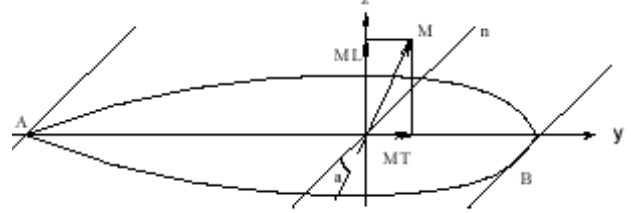

The stress in point A is determined as:

$$\sigma_B = \frac{M_{L,max}}{W_{zz}}$$

where:

$M_{L,max}$: max longitudinal bending moment in bracket, defined in [2.3.5].

W_{zz} : sectional modulus around the z axis.

The stress in point B is determined as:

$$\sigma_B = \frac{M_{T\phi}}{I_{yy}} Z_B + \frac{M_{L,max}}{I_{zz}} Y_B$$

where:

$M_{T\phi}$: transversal moment in bracket when the longitudinal moment is max, defined in [2.3.6],

I_{yy} : sectional moment of inertia around the y axis,

I_{zz} : sectional moment of inertia around the z axis,

Z_B : distance of point B to the neutral axis for transversal bending,

Y_B : distance of point B to the neutral axis for longitudinal bending.

2.3.4 Compressive stress

The compressive stress acting in the brackets when the longitudinal bending moment is maximised is to be determined as:

$$\sigma_c = \frac{P}{2A} \left(\frac{\sin \phi}{\sin \theta} + \frac{\cos \phi}{\cos \theta} \right)$$

where:

P : centrifugal force of lost blade in N, see Fig 6 , to be obtained as:

$$P = m\omega^2 \rho$$

where:

m : weight of blade, in kg,

ω : angular velocity in rad/s, defined as $2\pi\text{RPM}/60$, where RPM is the revolutions per minute of the propeller,

ρ : distance from centre of gravity of blade to propeller axis,

ϕ : phase angle for which the bending stress in the bracket is maximised.

The phase angle maximising the bending induced stress is to be determined from:

$$\tan \varphi = \frac{2K_6}{\tan \theta}$$

2.3.5 Max longitudinal moment in bracket

The maximum longitudinal bending moment, in Nm, acting in the brackets is defined as:

$$M_{L, \max} = \frac{4K_6^2 \cos \theta + \sin \theta \tan \theta}{2 \sin \theta \cos \theta \sqrt{4K_6^2 + \tan^2 \theta}} \left(P \cdot a_y + \frac{S \cdot D_e}{3} \right)$$

where:

- S : thrust of lost blade in N, see Fig 6, to be obtained as the total thrust of the propeller divided with the number of propeller blades,
- a_y : Distance from propeller to brackets, in m, see Fig 6.

Figure 6 : Definitions of forces, directions and distances

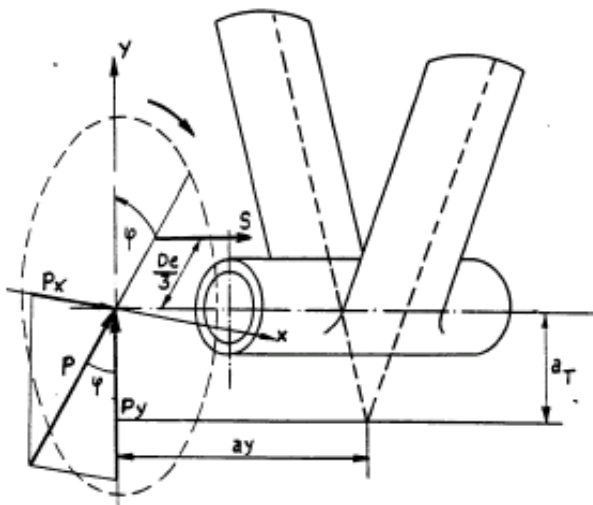

2.3.6 Max transversal moment in bracket

The maximum transversal bending moment, in Nm, acting in the brackets is defined as:

$$M_{T\varphi} = K_6 P \cdot a_T \frac{2K_6}{\sqrt{4K_6^2 + \tan^2 \theta}}$$

where:

- P : is defined in [2.3.4],
- a_T : defined in Fig 6, in m.

2.3.7 Resonance

In case of loss of a propeller blade it must be verified that the brackets lowest natural frequency f_1 is at least 20%

larger than the exciting frequency of the damaged propeller f_{dam} :

$$f_1 \geq f_{dam}$$

where:

- f_1 : is determined as described in [2.4.2].
- f_{dam} : RPM/60, in Hz, where RPM is the maximum number of revolutions per minute.

2.4 Other verifications

2.4.1 Stability under compression

It is to be verified that the maximum compressive stress σ_{max} does not exceed the critical instability stress σ_{cr} in N/m², which is defined as:

$$\sigma_{cr} = \pi^2 \frac{EI_{min}}{0,64AL^2}$$

where:

- I_{min} : minimum moment of inertia of the cross section, in m⁴,
 - E : Young's modulus = 2,06 10¹¹ N/m² for steel
- The maximum compressive stress acting on the brackets is defined as:

$$\sigma_{max} = \frac{P}{2A} \cdot \left(\frac{1}{\sin \theta \sqrt{1 + \tan^2 \theta}} + \frac{\tan \theta}{\cos \theta \sqrt{1 + \tan^2 \theta}} \right)$$

2.4.2 Resonance

In general, it is to be verified that either:

- a) the brackets lowest natural frequency f_1 exceeds with at least 20% the blade frequency f_{bl} , or,
- b) the blade frequency is at least twice as large as the brackets lowest natural frequency f_1 and 20% smaller than the second natural frequency f_2 .

Which can be expressed as:

- a) $f_1 \geq 1,20f_{bl}$
- b) $0,8 f_2 \geq f_{bl} \geq 2f_1$

where:

- f_{bl} : blade frequency in Hz, defined as; $f_{bl} = n \cdot \text{RPM} / 60$ where n is the number of blades and RPM is the maximum number of revolutions per minute,

$$f_i = \frac{\lambda_i^2}{2\pi L^2} \sqrt{\frac{EI_{min}}{W + w_e}}$$

where:

- λ_1 : factor equal to 1,875 in case of a single arm bracket and equal to 3,927 in case of double arm brackets,
- λ_2 : factor equal to 4,694 in case of a single arm bracket and equal to 7,069 in case of double arm brackets,

E and I_{min} : are defined in [2.4.1],

w : mass of the bracket per unit length, in kg/m,

w_e : added mass of water per unit length, in kg/m.
 The added mass of water is to be determined as, unless otherwise agreed with the Society:

$$w_e = \rho(A_{cir} - A)$$

where:

ρ : density of sea water, equal to 1025 kg/m³
 A_{cir} : area of circle circumscribing the bracket profile, in m², see Fig 7.

Figure 7 : Added mass of water surrounding the bracket

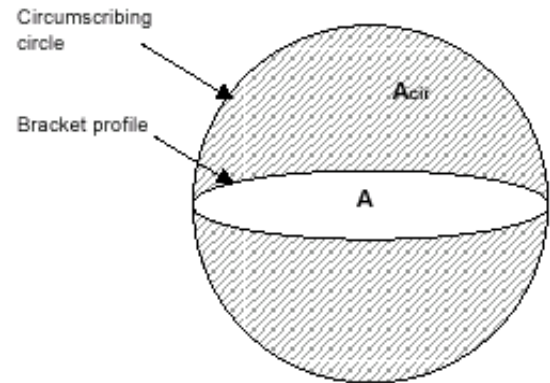

SECTION 4

EQUIPMENT

Symbols

EN : Equipment Number defined in [2.1],

1 General

1.1 General

1.1.1 The requirements in [2] to [3] apply to temporary mooring of a ship within or near harbour, or in a sheltered area, when the ship is awaiting a berth, the tide, etc.

Therefore, the equipment complying with the requirements in [2] to [3] is not intended for holding a ship off fully exposed coasts in rough weather or for stopping a ship which is moving or drifting.

1.1.2 The equipment complying with the requirements in [2] to [3] is intended for holding a ship in good holding ground, where the conditions are such as to avoid dragging of the anchor. In poor holding ground the holding power of the anchors is to be significantly reduced.

1.1.3 It is assumed that under normal circumstances a ship will use one anchor only.

2 Equipment number

2.1 Equipment number

2.1.1 General (1/1/2017)

All ships are to be provided with equipment in anchors and chain cables (or ropes according to [3.3.5]), to be obtained from Tab 1, based on their Equipment Number EN.

In general, stockless anchors are to be adopted.

For ships with EN greater than 16000, the determination of the equipment will be considered by the Society on a case by case basis.

For ships having the navigation notation **coastal area** or **sheltered area**, the equipment in anchors and chain cables may be reduced. The reduction consists of entering Tab 1 one line higher for ships having the navigation notation **coastal area** and two lines higher for ships having the navigation notation **sheltered area**, based on their Equipment Number EN.

For ships of special design or ships engaged in special services or on special voyages, the Society may consider equipment other than that in Tab 1.

Table 1 : Equipment

Equipment number EN A < EN ≤ B		Stockless anchors		Stud link chain cables for anchors			
A	B	N (1)	Mass per anchor, in kg	Total length, in m	Diameter, in mm		
					Q1	Q2	Q3
50	70	2	180	220,0	14,0	12,5	
70	90	2	240	220,0	16,0	14,0	
90	110	2	300	247,5	17,5	16,0	
110	130	2	360	247,5	19,0	17,5	
130	150	2	420	275,0	20,5	17,5	
150	175	2	480	275,0	22,0	19,0	
175	205	2	570	302,5	24,0	20,5	
205	240	3	660	302,5	26,0	22,0	20,5
240	280	3	780	330,0	28,0	24,0	22,0
280	320	3	900	357,5	30,0	26,0	24,0
320	360	3	1020	357,5	32,0	28,0	24,0
360	400	3	1140	385,0	34,0	30,0	26,0
400	450	3	1290	385,0	36,0	32,0	28,0
450	500	3	1440	412,5	38,0	34,0	30,0
500	550	3	1590	412,5	40,0	34,0	30,0
550	600	3	1740	440,0	42,0	36,0	32,0
600	660	3	1920	440,0	44,0	38,0	34,0
660	720	3	2100	440,0	46,0	40,0	36,0
720	780	3	2280	467,5	48,0	42,0	36,0

(1) See [3.2.4].

Equipment number EN A < EN ≤ B		Stockless anchors		Stud link chain cables for anchors			
		N (1)	Mass per anchor, in kg	Total length, in m	Diameter, in mm		
A	B				Q1	Q2	Q3
780	840	3	2460	467,5	50,0	44,0	38,0
840	910	3	2640	467,5	52,0	46,0	40,0
910	980	3	2850	495,0	54,0	48,0	42,0
980	1060	3	3060	495,0	56,0	50,0	44,0
1060	1140	3	3300	495,0	58,0	50,0	46,0
1140	1220	3	3540	522,5	60,0	52,0	46,0
1220	1300	3	3780	522,5	62,0	54,0	48,0
1300	1390	3	4050	522,5	64,0	56,0	50,0
1390	1480	3	4320	550,0	66,0	58,0	50,0
1480	1570	3	4590	550,0	68,0	60,0	52,0
1570	1670	3	4890	550,0	70,0	62,0	54,0
1670	1790	3	5250	577,5	73,0	64,0	56,0
1790	1930	3	5610	577,5	76,0	66,0	58,0
1930	2080	3	6000	577,5	78,0	68,0	60,0
2080	2230	3	6450	605,0	81,0	70,0	62,0
2230	2380	3	6900	605,0	84,0	73,0	64,0
2380	2530	3	7350	605,0	87,0	76,0	66,0
2530	2700	3	7800	632,5	90,0	78,0	68,0
2700	2870	3	8300	632,5	92,0	81,0	70,0
2870	3040	3	8700	632,5	95,0	84,0	73,0
3040	3210	3	9300	660,0	97,0	84,0	76,0
3210	3400	3	9900	660,0	100,0	87,0	78,0
3400	3600	3	10500	660,0	102,0	90,0	78,0
3600	3800	3	11100	687,5	105,0	92,0	81,0
3800	4000	3	11700	687,5	107,0	95,0	84,0
4000	4200	3	12300	687,5	111,0	97,0	87,0
4200	4400	3	12900	715,0	114,0	100,0	87,0
4400	4600	3	13500	715,0	117,0	102,0	90,0
4600	4800	3	14100	715,0	120,0	105,0	92,0
4800	5000	3	14700	742,5	122,0	107,0	95,0
5000	5200	3	15400	742,5	124,0	111,0	97,0
5200	5500	3	16100	742,5	127,0	111,0	97,0
5500	5800	3	16900	742,5	130,0	114,0	100,0
5800	6100	3	17800	742,5	132,0	117,0	102,0
6100	6500	3	18800	742,5		120,0	107,0
6500	6900	3	20000	770,0		124,0	111,0
6900	7400	3	21500	770,0		127,0	114,0
7400	7900	3	23000	770,0		132,0	117,0
7900	8400	3	24500	770,0		137,0	122,0
8400	8900	3	26000	770,0		142,0	127,0
8900	9400	3	27500	770,0		147,0	132,0
9400	10000	3	29000	770,0		152,0	132,0
10000	10700	3	31000	770,0			137,0
10700	11500	3	33000	770,0			142,0
11500	12400	3	35500	770,0			147,0
12400	13400	3	38500	770,0			152,0
13400	14600	3	42000	770,0			157,0
14600	16000	3	46000	770,0			162,0

(1) See [3.2.4].

2.1.2 Equipment Number for ships with perpendicular superstructure front bulkhead (1/1/2017)

The Equipment Number EN is to be obtained from the following formula:

$$EN = \Delta^{2/3} + 2 A_T + 0,1 A$$

where:

- Δ : moulded displacement of the ship, in t, to the summer load waterline,
- A_T : transverse projected area, in m², of the hull and of all superstructures, houses, masts, etc., above the design draught having a breadth greater than B/4
- A : area, in m², in profile view, of the parts of the hull, superstructures and houses above the summer load waterline which are within the length L_E and also have a breadth greater than B/4,

L_E : equipment length, in m, equal to L without being taken neither less than 96% nor greater than 97% of the total length of the summer load waterline.

Fixed screens or bulwarks 1,5 m or more in height are to be regarded as parts of houses when determining A.

Where a screen or bulwark is of varying height, the portion to be included is to be that length the height of which exceeds 1,5 m.

2.1.3 Equipment Number for ships with inclined superstructure front bulkhead

For ships having superstructures with the front bulkhead with an angle of inclination aft, the Equipment Number EN is to be obtained from the following formula:

$$EN = \Delta^{2/3} + 2 (a B + \sum b_N h_N \sin \theta_N) + 0,1 A$$

where:

**Figure 1 : Ships with perpendicular front bulkhead
Effective area of bulwarks or fixed screen to be included in the Equipment Number**

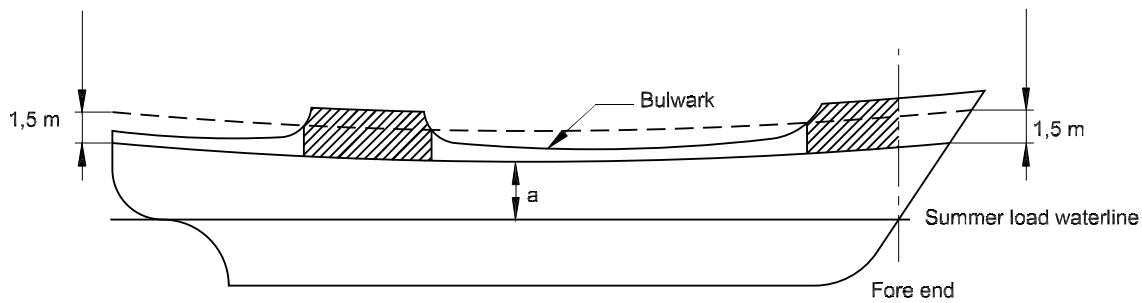

**Figure 2 : Ships with inclined front bulkhead
Effective area of bulwarks or fixed screen to be included in the Equipment Number**

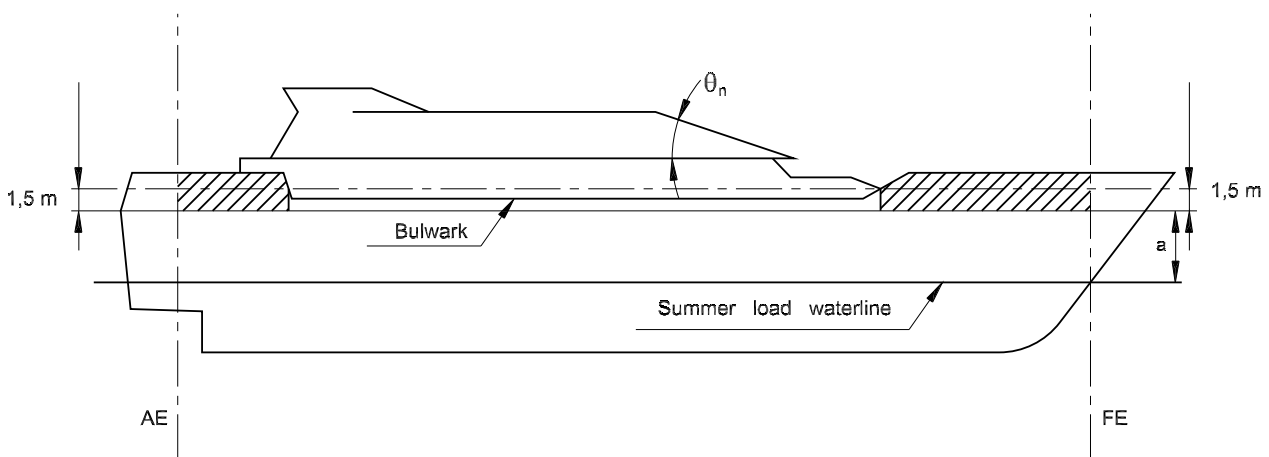

Δ, a, h_N, A : as defined in [2.1.2]

θ_N : angle of inclination aft of each front bulkhead, shown in Fig 2,

b_N : greatest breadth, in m, of each tier n of superstructures or deckhouses having a breadth greater than B/4.

Fixed screens or bulwarks 1,5 m or more in height are to be regarded as parts of houses when determining h and A. In particular, the hatched area shown in Fig 2 is to be included.

3 Equipment

3.1 Shipboard fittings and supporting hull structures

3.1.1 Application

The requirements of [3.1] apply to bollards, bits, fairleads, stand rollers, chocks used for the normal mooring of the ship and similar components used for the normal towing of the ship.

The supporting hull structures are constituted by that part of the ship's structure on/in which the shipboard fitting is placed and which is directly submitted to the forces exerted on the shipboard fitting. The supporting hull structures of capstans, winches, etc used for normal towing and mooring operations are also covered by [3.1].

Other components such as capstans, winches, etc are not covered by this item. Any weld or bolt or equivalent device connecting the shipboard fitting to the supporting structure is part of the shipboard fitting and subject to the industry standard applicable to this shipboard fitting.

3.1.2 Net scantlings

The net minimum scantlings of the supporting hull structure are to comply with the requirements in [3.1.8] and [3.1.14]. The net thicknesses, t_{net} , are the member thicknesses necessary to obtain the above required minimum net scantlings. The required gross thicknesses are obtained by adding the total corrosion additions, t_c , given in [3.1.3], to t_{net} .

3.1.3 Corrosion Addition

The total corrosion addition, t_c , in mm, for both sides of the hull supporting structure is to be in accordance with Ch 4, Sec 2 and, in any case, it is to be not less than 2,0 mm.

3.1.4 Towing shipboard fittings selection

The selection of towing shipboard fittings is to be made by the shipyard in accordance with an industry standard (e.g. ISO 3913 Shipbuilding Welded Steel Bollards) accepted by the Society. When the shipboard fitting is not selected from an accepted industry standard, the design load considered for assessing its strength and its attachment to the ship is to be in accordance with [3.1.13].

3.1.5 Towing shipboard fittings location

Shipboard fittings for towing are to be located on longitudinal ordinary stiffeners, beams and/or girders which are part of the deck construction so as to facilitate efficient distribution of the towing loads. Other equivalent arrangements (e.g. Panama chocks) may be accepted provided the strength is confirmed adequate for the intended service.

3.1.6 Arrangement of supporting hull structures for towing fittings

The arrangement of the reinforced members (carling) beneath towing shipboard fittings is to be such as to withstand any variation of direction (laterally and vertically) of the towing forces defined in accordance with [3.1.7], acting through the arrangement of connection to the shipboard fittings.

3.1.7 Arrangement of supporting hull structures for towing fittings

Unless a greater safe working load (SWL) of shipboard fittings is specified by the applicant, the minimum design load to be used is the following value of (a) or (b), whichever is applicable:

- for normal towing operations (e.g. harbour/manoeuvring), 1,25 times the intended maximum towing load (e.g. static bollard pull) as indicated on the towing and mooring arrangement plan.
- for other towing service, the nominal breaking strength of the towline according to Table 3 for the ship's corresponding EN is to be applied.

This force is to be considered as acting on the shipboard fittings at the attachment point of the towing line or mooring line or at a change in its direction, as applicable.

The design load is to be applied through the towline according to the arrangement shown on the towing and mooring arrangement plan.

When a specific SWL is applied for a shipboard fitting at the request of the applicant, by which the design load will be greater than the above minimum values, the strength of the fitting is to be designed using this specific design load.

The method of application of the design load to the fittings and supporting hull structures is to be taken into account such that the total load need not be more than twice the design load, i.e. no more than one turn of one line (see Fig 1).

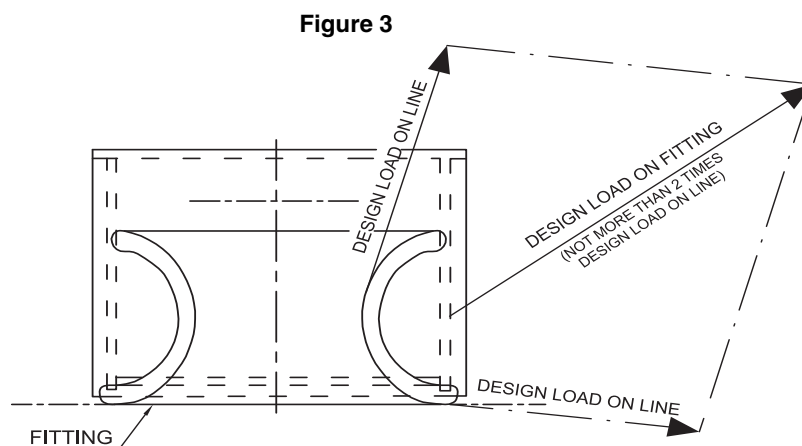

3.1.8 Allowable stresses for towing fittings

When assessing the strength of supporting hull structures for towing fittings, the following allowable stresses are to be considered in association with a stress calculation that does not take into account any stress concentration factors:

- normal stress: the minimum yield stress of the supporting hull structure material
- shear stress: 0,6 times the minimum yield stress of the supporting hull structure material.

Normal stress is the sum of bending stress and axial stress with the corresponding shearing stress acting perpendicular to the normal stress.

3.1.9 Safe Working Load (SWL)

The SWL used for normal towing operations (e.g. harbour/manoeuvring) is not to exceed 80% of the design load as per [3.1.7] a) and the SWL used for other towing operations (e.g. escort) is not to exceed the design load as per [3.1.7] b). For fittings used for both normal and other towing operations, the greater of the design loads of [3.1.7] a) and [3.1.7] b) is to be used.

The SWL of each shipboard fitting is to be marked (by weld bead or equivalent) on the deck fittings used for towing.

The above requirements on SWL apply on a single post basis (no more than one turn of one cable).

The towing and mooring arrangement plan mentioned in [3.1.16] is to define the method of use of towing lines.

3.1.10 Mooring shipboard fittings selection

The selection of mooring shipboard fittings is to be made by the shipyard in accordance with an industry standard (e.g. ISO 3913 Shipbuilding Welded Steel Bollards) accepted by the Society. When the shipboard fitting is not selected from an accepted industry standard, the design load considered for assessing its strength and its attachment to the ship is to be in accordance with [3.1.13]

3.1.11 Mooring shipboard fittings location

Shipboard fittings for mooring are to be located on longitudinals, beams and/or girders which are part of the deck construction so as to facilitate efficient distribution of the mooring load. Other arrangements may be accepted (for Panama chocks, etc) provided the strength is confirmed adequate for the service.

3.1.12 Arrangement of supporting hull structures for mooring fittings

The arrangement of the reinforced members (carling) beneath mooring shipboard fittings is to be such as to withstand any variation of direction (laterally and vertically) of the mooring forces defined in accordance with [3.1.13], acting through the arrangement of connection to the shipboard fittings.

3.1.13 Mooring load model

- a) Unless a greater safe working load (SWL) of shipboard fittings is specified by the applicant, the design load applied to shipboard fittings and supporting hull structures is to be 1,25 times the breaking strength of the mooring line according to Tab 3 for the ship's corresponding EN (see Note 1).

Note 1: Side projected area including maximum stacks of deck cargoes is to be taken into account for assessment of lateral wind forces, arrangements of tug boats and selection of mooring lines.

- b) The design load applied to supporting hull structures for winches, etc is to be 1,25 times the intended maximum brake holding load and, for capstans, 1,25 times the maximum hauling-in force.
- c) This force is to be considered as acting on the shipboard fittings at the attachment point of the mooring line or at a change in its direction, as applicable.
- d) The design load is to be applied through the mooring line according to the arrangement shown on the towing and mooring arrangement plan.
- e) The method of application of the design load to the fittings and supporting hull structures is to be taken into account such that the total load need not be more than twice the design load specified above, i.e. no more than one turn of one line.
- f) When a specific SWL is applied for a shipboard fitting at the request of the applicant, by which the design load will be greater than the above minimum values, the strength of the fitting is to be designed using this specific design load.

3.1.14 Allowable stresses for mooring fittings

When assessing the strength of supporting hull structures for mooring fittings, the following allowable stresses are to be considered in association with a stress calculation that does not take into account any stress concentration factors:

- normal stress: the minimum yield stress of the supporting hull structure material
- shear stress: 0,6 times the minimum yield stress of the supporting hull structure material.

Normal stress is the sum of bending stress and axial stress with the corresponding shearing stress acting perpendicular to the normal stress.

3.1.15 Safe Working Load (SWL)

The SWL is not to exceed 80% of the design load as per [3.1.13] a).

The SWL of each shipboard fitting is to be marked (by weld bead or equivalent) on the deck fittings used for mooring.

The above requirements on SWL apply on a single post basis (no more than one turn of one cable).

The towing and mooring arrangement plan mentioned in [3.1.16] is to define the method of use of mooring lines.

3.1.16 Towing and mooring arrangement plan

The SWL for the intended use for each shipboard fitting is to be noted in the towing and mooring arrangement plan available on board for the guidance of the Master.

Information provided on the plan is to include in respect of each shipboard fitting:

- location on the ship;
- fitting type;
- SWL;
- purpose (mooring/harbour towing); and
- manner of applying towing or mooring line load including limiting fleet angles.

Where the arrangements and details of deck fittings and their supporting hull structures are designed based on the mooring arrangements as permitted in [3.5.4], the following information is to be clearly indicated on the plan:

- the arrangement of mooring lines showing the number of lines (N), together with
- the breaking strength of each mooring line (BS).

3.2 Anchors

3.2.1 General

The anchoring arrangement is to be such as to prevent the cable from being damaged and fouled. Adequate arrangements are to be provided to secure the anchor under all operational conditions.

The scantlings of anchors are to be in compliance with the following requirements.

Anchors are to be manufactured according to approved plans or recognized standards and are to be tested as indicated in Pt D, Ch 4, Sec 1, [1] of the Rules for the Classification of Ships.

3.2.2 Ordinary anchors

The required mass for each anchor is to be obtained from Tab 1.

The individual mass of a main anchor may differ by $\pm 7\%$ from the mass required for each anchor, provided that the total mass of anchors is not less than the total mass required in Tab 1.

The mass of the head of an ordinary stockless anchor, including pins and accessories, is to be not less than 60% of the total mass of the anchor.

Where a stock anchor is provided, the mass of the anchor, excluding the stock, is to be not less than 80% of the mass required in Tab 1 for a stockless anchor. The mass of the stock is to be not less than 25% of the mass of the anchor without the stock but including the connecting shackle.

3.2.3 High and very high holding power anchors

High holding power (HHP) and very high holding power (VHHP) anchors, i.e. anchors for which a holding power higher than that of ordinary anchors has been proved according to Pt D, Ch 4, Sec 1, [1] of the Rules for the Classification of the Ships, do not require prior adjustment or special placement on the sea bottom.

Where HHP or VHHP anchors are used as bower anchors, the mass of each anchor is to be not less than 75% or 50%, respectively, of that required for ordinary stockless anchors in Tab 1.

The mass of VHHP anchors is to be, in general, less than or equal to 1500 kg.

3.2.4 Third anchor (1/1/2017)

Where three anchors are provided, two are to be connected to their own chain cables and positioned on board always ready for use.

The third anchor is intended as a spare and is not compulsory for the purpose of classification.

3.2.5 Test for high holding power anchors approval

For approval and/or acceptance as a HHP anchor, comparative tests are to be performed on various types of sea bottom. Such tests are to show that the holding power of the HHP anchor is at least twice the holding power of an ordinary stockless anchor of the same mass.

For approval and/or acceptance as a HHP anchor of a whole range of mass, such tests are to be carried out on anchors whose sizes are, as far as possible, representative of the full range of masses proposed. In this case, at least two anchors of different sizes are to be tested. The mass of the maximum size to be approved is to be not greater than 10 times the maximum size tested. The mass of the smallest is to be not less than 0,1 times the minimum size tested.

3.2.6 Test for very high holding power anchors approval

For approval and/or acceptance as a VHHP anchor, comparative tests are to be performed at least on three types of sea bottom: soft mud or silt, sand or gravel and hard clay or similar compounded material. Such tests are to show that the holding power of the VHHP anchor is to be at least four times the holding power of an ordinary stockless anchor of the same mass or at least twice the holding power of a previously approved HHP anchor of the same mass.

The holding power test load is to be less than or equal to the proof load of the anchor, specified in Pt D, Ch 4, Sec 1, [1.6] of the Rules for the Classification of the Ships.

For approval and/or acceptance as a VHHP anchor of a whole range of mass, such tests are to be carried out on anchors whose sizes are, as far as possible, representative of the full range of masses proposed. In this case, at least three anchors of different sizes are to be tested. relevant to the bottom, middle and top of the mass range.

3.2.7 Specification for test on high holding power and very high holding power anchors

Tests are generally to be carried out from a tug. Shore based tests may be accepted by the Society on a case-by-case basis.

Alternatively, sea trials by comparison with a previous approved anchor of the same type (HHP or VHHP) of the one to be tested may be accepted by the Society on a case-by-case basis.

For each series of sizes, the two anchors selected for testing (ordinary stockless and HHP anchors for testing HHP anchors, ordinary stockless and VHHP anchors or, when

ordinary stockless anchors are not available, HHP and VHHP anchors for testing VHHP anchors) are to have the same mass.

The length of chain cable connected to each anchor, having a diameter appropriate to its mass, is to be such that the pull on the shank remains practically horizontal. For this purpose a value of the ratio between the length of the chain cable paid out and the water depth equal to 10 is considered normal. A lower value of this ratio may be accepted by the Society on a case-by-case basis.

Three tests are to be carried out for each anchor and type of sea bottom.

The pull is to be measured by dynamometer; measurements based on the RPM/bollard pull curve of tug may, however, be accepted instead of dynamometer readings.

Note is to be taken where possible of the stability of the anchor and its ease of breaking out.

3.3 Chain cables for anchors

3.3.1 Material

The chain cables are classified as grade Q1, Q2 or Q3 depending on the type of steel used and its manufacture.

The characteristics of the steel used and the method of manufacture of chain cables are to be approved by the Society for each manufacturer.

The material from which chain cables are manufactured and the completed chain cables themselves are to be tested in accordance with the applicable requirements of Pt D, Ch 4, Sec 1 of the Rules for the Classification of the Ships.

Chain cables made of grade Q1 may not be used with high holding power and very high holding power anchors.

3.3.2 Scantlings of stud link chain cables

The mass and geometry of stud link chain cables, including the links, are to be in compliance with the requirements in Pt D, Ch 4, Sec 1 of the Rules for the Classification of the Ships.

The diameter of stud link chain cables is to be not less than the value in Tab 1.

3.3.3 Studless link chain cables

For ships with EN less than 90, studless short link chain cables may be accepted by the Society as an alternative to stud link chain cables, provided that the equivalence in strength is based on proof load, defined in Pt D, Ch 4, Sec 1, [3] of the Rules for the Classification of the Ships, and that the steel grade of the studless chain is equivalent to the steel grade of the stud chains it replaces, as defined in [3.3.1].

3.3.4 Chain cable arrangement

Chain cables are to be made by lengths of 27,5 m each, joined together by Dee or lugless shackles.

The total length of chain cable, required in Tab 1, is to be divided in approximately equal parts between the two anchors ready for use.

Where different arrangements are provided, they are considered by the Society on a case-by-case basis.

Where the ship may anchor in areas with current speed greater than 2,5 m/s, the Society may require a length of heavier chain cable to be fitted between the anchor and the rest of the chain in order to enhance anchor bedding.

3.3.5 Wire ropes

As an alternative to the stud link or short link chain cables mentioned, wire ropes may be used in the following cases:

- wire ropes for both the anchors, for ship length less than 30 m,
- wire rope for one of the two anchors, for ship length between 30 m and 40 m.

The wire ropes above are to have a total length equal to 1,5 times the corresponding required length of stud link chain cables, obtained from Tab 1, and a minimum breaking load equal to that given for the corresponding stud link chain cable (see [3.3.2]).

A short length of chain cable is to be fitted between the wire rope and the anchor, having a length equal to 12,5m or the distance from the anchor in the stowed position to the winch, whichever is the lesser.

3.4 Attachment pieces

3.4.1 General

Where the lengths of chain cable are joined to each other by means of shackles of the ordinary Dee type, the anchor may be attached directly to the end link of the first length of chain cable by a Dee type end shackle.

A detachable open link in two parts riveted together may be used in lieu of the ordinary Dee type end shackle; in such case the open end link with increased diameter, defined in [3.4.2], is to be omitted.

Where the various lengths of chain cable are joined by means of lugless shackles and therefore no special end and increased diameter links are provided, the anchor may be attached to the first length of chain cable by a special pear-shaped lugless end shackle or by fitting an attachment piece.

3.4.2 Scantlings

The diameters of the attachment pieces, in mm, are to be not less than the values indicated in Tab 2.

Table 2 : Diameters of attachment pieces

Attachment piece	Diameter, in mm
End shackle	1,4 d
Open end link	1,2 d
Increased stud link	1,1 d
Common stud link	d
Lugless shackle	d
Note 1: d : diameter, in mm, of the common link.	

Attachment pieces may incorporate the following items between the increased diameter stud link and the open end link:

- swivel, having diameter = 1,2 d
- increased stud link, having diameter = 1,1 d

Where different compositions are provided, they will be considered by the Society on a case-by-case basis.

3.4.3 Material

Attachment pieces, joining shackles and end shackles are to be of such material and design as to provide strength equivalent to that of the attached chain cable, and are to be tested in accordance with the applicable requirements of Pt D, Ch 4, Sec 1 of the Rules for the Classification of the Ships.

3.4.4 Spare attachment pieces

A spare pear-shaped lugless end shackle or a spare attachment piece is to be provided for use when the spare anchor is fitted in place.

3.5 Towlines and mooring lines

3.5.1 General

The towlines having the characteristics defined in Tab 2 are intended as those belonging to the ship to be towed by a tug or another ship.

3.5.2 Materials

Towlines and mooring lines may be of wire, natural or synthetic fibre or a mixture of wire and fibre.

The breaking loads defined in Tab 2 refer to steel wires or natural fibre ropes.

Steel wires and fibre ropes are to be tested in accordance with the applicable requirements in Pt D, Ch 4, Sec 1 of the Rules for the Classification of the Ships.

3.5.3 Steel wires

Steel wires are to be made of flexible galvanised steel and are to be of types defined in Tab 3.

Where the wire is wound on the winch drum, steel wires to be used with mooring winches may be constructed with an independent metal core instead of a fibre core. In general such wires are to have not less than 186 threads in addition to the metallic core.

3.5.4 Number of mooring lines

When the breaking load of each mooring line is greater than 490kN, either a greater number of mooring lines than those required in Tab 3 having lower strength or a lower number of mooring lines than those required in Tab 3 having greater strength may be used, provided the total breaking load of all lines aboard the ship is greater than the value defined in Tab 3.

In any case, the number of lines is to be not less than 6 and the breaking load of each line is to be greater than 490kN.

3.5.5 Length of mooring lines

The length of individual mooring lines may be reduced by up to 7% of the length defined in Tab 2, provided that the total length of mooring lines is greater than that obtained by adding the lengths of the individual lines defined in Tab 2.

Table 3 : Towlines and mooring lines

Equipment number EN A < EN ≤ B		Towline (1)		Mooring lines		
A	B	Minimum length, in m	Breaking load, in kN	N	Length of each line, in m	Breaking load, in kN
50	70	180	98,1	3	80	34
70	90	180	98,1	3	100	37
90	110	180	98,1	3	110	39
110	130	180	98,1	3	110	44
130	150	180	98,1	3	120	49
150	175	180	98,1	3	120	54
175	205	180	112	3	120	59
205	240	180	129	4	120	64
240	280	180	150	4	120	69
280	320	180	174	4	140	74
320	360	180	207	4	140	78
360	400	180	224	4	140	88
400	450	180	250	4	140	98
450	500	180	277	4	140	108
500	550	190	306	4	160	123
550	600	190	338	4	160	132
600	660	190	371	4	160	147
660	720	190	406	4	160	157
720	780	190	441	4	170	172
780	840	190	480	4	170	186
840	910	190	518	4	170	201
910	980	190	550	4	170	216
980	1060	200	603	4	180	230
1060	1140	200	647	4	180	250
1140	1220	200	692	4	180	270
1220	1300	200	739	4	180	284
1300	1390	200	786	4	180	309
1390	1480	200	836	4	180	324
1480	1570	220	889	5	190	324
1570	1670	220	942	5	190	333
1670	1790	220	1024	5	190	353
1790	1930	220	1109	5	190	378
1930	2080	220	1168	5	190	402
2080	2230	240	1259	5	200	422
2230	2380	240	1356	5	200	451
2380	2530	240	1453	5	200	481
2530	2700	260	1471	6	200	481
2700	2870	260	1471	6	200	490
2870	3040	260	1471	6	200	500
3040	3210	280	1471	6	200	520
3210	3400	280	1471	6	200	554
3400	3600	280	1471	6	200	588
3600	3800	300	1471	6	200	612
3800	4000	300	1471	6	200	647
4000	4200	300	1471	7	200	647
4200	4400	300	1471	7	200	657
4400	4600	300	1471	7	200	667

(1) The towline is not compulsory. It is recommended for ships having length not greater than 180 m.

Equipment number EN A < EN ≤ B		Towline (1)		Mooring lines		
A	B	Minimum length, in m	Breaking load, in kN	N	Length of each line, in m	Breaking load, in kN
4600	4800	300	1471	7	200	677
4800	5000	300	1471	7	200	686
5000	5200	300	1471	8	200	686
5200	5500	300	1471	8	200	696
5500	5800	300	1471	8	200	706
5800	6100	300	1471	9	200	706
6100	6500			9	200	716
6500	6900			9	200	726
6900	7400			10	200	726
7400	7900			11	200	726
7900	8400			11	200	735
8400	8900			12	200	735
8900	9400			13	200	735
9400	10000			14	200	735
10000	10700			15	200	735
10700	11500			16	200	735
11500	12400			17	200	735
12400	13400			18	200	735
13400	14600			19	200	735
14600	16000			21	200	735

(1) The towline is not compulsory. It is recommended for ships having length not greater than 180 m.

Table 4 : Steel wire composition

Breaking load B_L , in kN	Steel wire components		
	Number of threads	Ultimate tensile strength of threads, in N/mm ²	Composition of wire
$B_L < 216$	72	1420 ÷ 1570	6 strands with 7-fibre core
$216 < B_L < 490$	144	1570 ÷ 1770	6 strands with 7-fibre core
$B_L > 490$	216 or 222	1770 ÷ 1960	6 strands with 1-fibre core

3.5.6 Equivalence between the breaking loads of synthetic and natural fibre ropes

Generally, fibre ropes are to be made of polyamide or other equivalent synthetic fibres.

The equivalence between the breaking loads of synthetic fibre ropes B_{LS} and of natural fibre ropes B_{LN} is to be obtained, in kN, from the following formula:

$$B_{LS} = 7,4 \delta B_{LN}^{8/9}$$

where:

δ : elongation to breaking of the synthetic fibre rope, to be assumed not less than 30%.

3.6 Hawse pipes

3.6.1 Hawse pipes are to be built according to sound marine practice.

Their position and slope are to be so arranged as to create an easy lead for the chain cables and efficient housing for the anchors, where the latter are of the retractable type, avoiding damage to the hull during these operations.

For this purpose chafing lips of suitable form with ample lay-up and radius adequate to the size of the chain cable are to be provided at the shell and deck. The shell plating in way of the hawse pipes is to be reinforced as necessary.

3.6.2 In order to obtain an easy lead of the chain cables, the hawse pipes may be provided with rollers. These rollers are to have a nominal diameter not less than 10 times the size of the chain cable where they are provided with full imprints, and not less than 12 times its size where provided with partial imprints only.

3.6.3 All mooring units and accessories, such as tumbler, riding and trip stoppers are to be securely fastened to the Surveyor's satisfaction.

3.7 Windlass

3.7.1 General

The windlass, which is generally single, is to be power driven and suitable for the size of chain cable and the mass of the anchors.

In mechanically propelled ships of less than 200 t gross tonnage, a hand-operated windlass may be fitted. In such case it is to be so designed as to be capable of weighing the anchors in a reasonably short time.

The windlass is to be fitted in a suitable position in order to ensure an easy lead of the chain cables to and through the hawse pipes. The deck in way of the windlass is to be suitably reinforced.

3.7.2 Assumptions for the calculation of the continuous duty pull

The calculation of the continuous duty pull P_C that the windlass unit prime mover is to be able to supply is based on the following assumptions:

- ordinary stockless anchors,
- wind force equal to 6 on Beaufort Scale,
- water current velocity 3 knots,
- anchorage depth 100 m,
- P_C includes the influences of buoyancy and hawse pipe efficiency; the latter is assumed equal to 70%,
- the anchor masses assumed are those defined in Pt D, Ch 4, Sec 1 of the Rules for the Classification of the Ships, excluding tolerances,
- only one anchor is assumed to be raised at a time.

Owing to the buoyancy, the chain masses assumed are smaller than those defined in Pt D, Ch 4, Sec 1 of the Rules for the Classification of the Ships, and are obtained, per unit length of the chain cable, in kg/m, from the following formula:

$$m_L = 0,0218 d^2$$

where d is the chain cable diameter, in mm.

3.7.3 Calculation of the continuous duty pull

According to the assumptions in [3.7.2], the windlass unit prime mover is to be able to supply for a least 30 minutes a continuous duty pull P_C to be obtained, in kN, from Tab 5.

3.7.4 Temporary overload capacity

The windlass unit prime mover is to provide the necessary temporary overload capacity for breaking out the anchor.

The temporary overload capacity, or short term pull, is to be not less than 1,5 times the continuous duty pull P_C and it is to be provided for at least two minutes.

The speed in this overload period may be lower than the nominal speed specified in [3.7.5].

Table 5 : Continuous duty pull

Material of chain cables	Continuous duty pull, in kN
Mild steel	$P_C = 0,0375 d^2$
High tensile strength steel	$P_C = 0,0425 d^2$
Very high tensile strength steel	$P_C = 0,0475 d^2$
Note 1:	
d : chain cable diameter, in mm.	

3.7.5 Nominal hoisting speed

The nominal speed of the chain cable when hoisting the anchor and cable, to be assumed as an average speed, is to be not less than 0,15 m/s.

The speed is to be measured over two shots of chain cable during the entire trip; the trial is to commence with 3 shots (82,5 m) of chain fully submerged.

3.7.6 Windlass brake

A windlass brake is to be provided having sufficient capacity to stop the anchor and chain cable when paying out the latter with safety, in the event of failure of the power supply to the prime mover. Windlasses not actuated by steam are also to be provided with a non-return device.

A windlass with brakes applied and the cable lifter declutched is to be able to withstand a pull of 45% of the breaking load of the chain without any permanent deformation of the stressed parts or brake slip.

3.7.7 Chain stoppers

Where a chain stopper is fitted, it is to be able to withstand a pull of 80% of the breaking load of the chain.

Where a chain stopper is not fitted, the windlass is to be able to withstand a pull of 80% of the breaking load of the chain without any permanent deformation of the stressed part or brake slip.

3.7.8 Windlass strength criteria

The stresses on the parts of the windlass, its frame and stopper are to be less than the yield stress of the material used.

For the calculation of the above stresses, special attention is to be paid to:

- stress concentrations in keyways and other stress raisers,
- dynamic effects due to sudden starting or stopping of the prime mover or anchor chain,
- calculation methods and approximation.

3.7.9 Connection with deck

The windlass, its frame and the stoppers are to be efficiently bedded to the deck.

3.8 Chain stoppers

3.8.1 A chain stopper is generally to be fitted between the windlass and the hawse pipe in order to relieve the windlass of the pull of the chain cable when the ship is at anchor. A chain stopper is to be capable of withstanding a

pull of 80% of the breaking load of the chain cable. The deck at the chain stopper is to be suitably reinforced.

For the same purpose, a piece of chain cable may be used with a rigging screw capable of supporting the weight of the anchor when housed in the hawse pipe or a chain tensioner. Such arrangements are not to be considered as chain stoppers.

3.8.2 Where the windlass is at a distance from the hawse pipes and no chain stoppers are fitted, suitable arrangements are to be provided to lead the chain cables to the windlass.

3.9 Chain locker

3.9.1 The capacity of the chain locker is to be adequate to stow all chain cable equipment and provide an easy direct lead to the windlass.

3.9.2 Where two chains are used, the chain lockers are to be divided into two compartments, each capable of housing the full length of one line.

3.9.3 The inboard ends of chain cables are to be secured to suitably reinforced attachments in the structure by means of end shackles, whether or not associated with attachment pieces.

Generally, such attachments are to be able to withstand a force not less than 15% of the breaking load of the chain cable.

In an emergency, the attachments are to be easily released from outside the chain locker.

3.9.4 Where the chain locker is arranged aft of the collision bulkhead, its boundary bulkheads are to be watertight and a drainage system is to be provided.

3.10 Fairleads and bollards

3.10.1 Fairleads and bollards of suitable size and design are to be fitted for towing, mooring and warping operations.

SECTION 5

MASTS AND OTHER OUTFITTING COMPONENTS

1 Masts

1.1 Application

1.1.1 The requirements of this Article apply to the arrangement of masts fitted on weather deck or on superstructure decks for supporting lights or other important fittings having significant mass with respect to the one of the mast structure.

The requirements in [1.2] apply for static analysis of masts subjected to still water, inertial and wind loads.

The requirements in [1.3] apply for the dynamic analysis of masts.

1.2 Static analysis of masts

1.2.1 General

In general, the inertial loads acting on the mast structures are to be obtained from a complete analysis of the ship

motion and accelerations in irregular waves, whose results are to be submitted to the Society for approval. These loads are to be obtained as those that can be reached with a probability of 10^{-5} per cycle.

Extreme wind values are to be considered in association with these inertial loads.

However, when deemed acceptable by the Society, the design loads in [1.2.2] may be used for the structural analysis of masts.

1.2.2 Design loads

The design loads are constituted by still water, inertial and wind loads. The structural weight of the mast and the weight of the mast fittings and devices are to be taken into account when calculating the still water and inertial, as indicated in Tab 1.

Table 1 : Still water and inertial force

Ship condition	Load case	Still water F_s and inertial load F_{Wv} , in kN
Still water condition		$F_{S,X} = 0,035 g \sum_i W_i$ in x direction (1) $F_{S,Y} = 0,087 g \sum_i W_i$ in y direction (2) $F_{S,Z} = g \sum_i W_i$ in z direction
Upright condition	"a"	No inertial force
	"b"	$F_{W,X} = \sum_i a_{X1,i} W_i$ in x direction $F_{W,Z} = \sum_i a_{Z1,i} W_i$ in z direction
Inclined condition	"c"	$F_{W,Y} = C_{FA} \sum_i a_{Y2,i} W_i$ in y direction
	"d"	$F_{W,Z} = C_{FA} \sum_i a_{Z2,i} W_i$ in z direction

(1) Still water force corresponding to a ship's trim angle equal to 2° . Other trim angle values may be accepted if adequate documentation is provided to the Society

(2) Still water force corresponding to a ship's heel angle equal to 5° . Other heel angle values may be accepted if adequate documentation is provided to the Society

Note 1:

W_i : mass, in t, of each one of the N mast components considered ($i = 1$ to N). It includes also the mass of mast structure and the mass of mast fittings and devices

$a_{X1,i}$, $a_{Z1,i}$: reference values of the accelerations a_{X1} , a_{Z1} in the upright ship condition, defined in Ch 5, Sec 3, 3.4, calculated in way of the centre of gravity of each one of the N mast components considered ($i = 1$ to N)

$a_{Y2,i}$, $a_{Z2,i}$: reference values of the accelerations a_{Y2} , a_{Z2} in the inclined ship condition, defined in Ch 5, Sec 3, 3.4, calculated in way of the centre of gravity of each one of the N mast components considered ($i = 1$ to N)

C_{FA} : combination factor, to be taken equal to:

- $C_{FA} = 0,7$ for load case "c"
- $C_{FA} = 1,0$ for load case "d"

The wind force, to be considered as being perpendicular to the surface of the mast exposed to the wind, is to be obtained, in N, from the following formula:

$$F_w = 0,613 C_s V^2 A$$

where:

- C_s : shape coefficient, to be taken equal to:
- $C_s = 1,6$ for lattice and flat-sided masts
 - $C_s = 0,9$ for masts having circular cross-sections
 - $C_s = 1,2$ for mast fittings
- V : wind speed, in m/s, to be taken, in general, not less than 63 m/s
- A : projected area, in m^2 , of all the mast surfaces exposed to wind.

1.2.3 Structural analysis

In general, the structural analysis of masts is to be based on direct calculations performed through three-dimensional models. Direct calculations are to be carried out according to the following requirements:

- the structural modelling is to comply with the requirements in Ch 7, App 1, 1 to Ch 7, App 1, [3]
- the loads to be applied on the model are to comply with [1.2.1]
- the stress calculation is to comply with the requirements in Ch 7, App 1, [5]

However, structural analysis of masts based on isolate beam models, performed according to the requirements in Ch 7, Sec 3, [3], may be carried out when deemed acceptable by the Society depending on the structural typology and arrangement adopted for the mast.

When three-dimensional direct calculations are carried out, the structural model of the mast is to include a suitable portion of the hull structure supporting the mast, in order to avoid that the unavoidable inaccuracy in the modelling of the boundary conditions affect the results in the area to be analysed.

1.2.4 Strength check criteria of mast structures

The following strength check of mast structures are to be carried out:

- yielding check, to be carried out according to Ch 7, Sec 3
- local buckling check of plate panels, to be carried out according to Ch 7, Sec 1, [5]
- column buckling check, to be carried out according to Ch 7, Sec 3, [6.2] and Ch 7, Sec 3, [6.3].

1.3 Dynamic analysis of masts

1.3.1 General

The dynamic analysis of masts is to be based on direct calculations performed through three-dimensional models.

The criteria adopted for structural modelling are to comply with the requirements specified in Ch 7, App 1.

In any case, the mesh accuracy is to be such that the stiffness and the mass distribution of the model elements of the mast, of the mast foundation and of the surrounding hull structure properly represent those of the actual structure.

1.3.2 Normal mode analysis

It is to be checked that each normal mode frequency f_{Ni} , in Hz, of the mast is in compliance with one of the following formulae:

$$F_{Ni} < 0,7 f_{E,MIN}$$

$$F_{Ni} > 1,3 f_{E,MAX}$$

where:

$f_{E,MIN}, f_{E,MAX}$: the lesser and the greater values, in Hz, respectively, among the possible excitations frequencies due to the ship's motions or the propulsion system, to be calculated for the ship at the following speeds:

- cruise speed
- maximum continuous rate speed
- patrol speed.

The normal mode calculation method and the number of normal modes to be taken into account are considered by the Society on a case by case basis.

When at least one of the mast normal mode frequencies does not comply with the above formulae, a dynamic analysis is to be carried out according to the requirements in [1.3.2].

1.3.3 Dynamic analysis

It is to be checked that the dynamic effects induced in the mast by the ship's motions or propulsion system excitations are within the allowable limits, when this is required according to [1.3.2].

The dynamic effects are to be calculated by means of a dynamic analysis aiming at evaluating the response of the mast in the frequency domain.

When the dynamic analysis is based on normal models, their number is, in general, to be such that the modal effective mass is not less than 95% of the mass of the system constituted by the mast and its supporting structure.

The modal effective mass is defined as:

$$\sum_{i=1}^N \gamma_i^2$$

where γ_i is the i^{th} modal participation factor and N is the number of the considered normal modes.

The dynamic analysis criteria and the relevant allowable limits are considered by the Society on a case by case basis.

Where requested by the interested parties, the allowable limits may also take into account the serviceability limits of the mast fittings, i.e. the limits at which the efficiency of the mast fitting is impaired (e.g. because of excessive vibration level).

2 Outfitting components subjected to weapon firing loads

2.1 General

2.1.1 These requirements apply to the outfitting components that, because of their relative location with respect to a weapon, could be subjected to the weapon firing loads, but have not been designed to sustain them. Such compo-

nents are to be completely enclosed within a protecting structure whose strength with respect to the weapon firing loads is to be checked by means of the applicable formulae in Chapter 7, where the loads are to be calculated according to Ch 5, Sec 6, [8]

If necessary, the protecting structure is to be provided with openings and closing devices. The strength of the closing devices is to be checked against the weapon firing loads as the protecting structure.

APPENDIX 1 CRITERIA FOR DIRECT CALCULATION OF RUDDER LOADS

Symbols

- $l_{10}, l_{20}, l_{30}, l_{40}$: lengths, in m, of the individual girders of the rudder system (see Fig 1, Fig 2 and Fig 3)
- l_{50} : length, in m, of the solepiece (see Fig 2 and Fig 4)
- $J_{10}, J_{20}, J_{30}, J_{40}$: moments of inertia about the x axis, in cm^4 , of the individual girders of the rudder system having lengths $l_{10}, l_{20}, l_{30}, l_{40}$ (see Fig 1, Fig 2 and Fig 3). For rudders supported by a solepiece only, J_{20} indicates the moment of inertia of the pintle in the sole piece
- J_{50} : moment of inertia about the z axis, in cm^4 , of the solepiece (see Fig 2 and Fig 4)
- C_R : rudder force, in N, acting on the rudder blade, defined in Sec 1, [2.1.1]
- C_{R1}, C_{R2} : rudder forces, in N, defined in Sec 1, [2.2.3].

1 Criteria for direct calculation of the loads acting on the rudder structure

1.1 General

1.1.1 Application

The requirements of this Appendix apply to the following types of rudders:

- spade rudders (see Fig 1),
- 2 bearing rudders with solepiece (see Fig 2),
- 2 bearing semi-spade rudders with rudder horn (see Fig 3).

The requirements of this Appendix provide the criteria for calculating the following loads:

- bending moment M_B in the rudder stock,
- support forces F_A ,
- bending moment M_R and shear force Q_R in the rudder body.

1.1.2 Load calculation

The loads in [1.1.1] are to be calculated through direct calculations based on the model specified in Fig 1, Fig 2 and Fig 3, depending on the type of rudder.

They are to be used for the stress analysis required in:

- Sec 1, [4], for the rudder stock,
- Sec 1, [6], for the rudder pintles and the pintle bearings,
- Sec 1, [7] for the rudder blade,
- Sec 1, [8] for the rudder horn and the solepiece.

1.1.3 Specific case of spade rudders

For spade rudders, the results of direct calculations carried out in accordance with [1.1.2] may be expressed in an analytical form. The loads in [1.1.1] may therefore be obtained from the following formulae:

- maximum bending moment in the rudder stock, in N.m:

$$M_B = C_R \left(l_{20} + \frac{l_{10}(2C_1 + C_2)}{3(C_1 + C_2)} \right)$$

where C_1 and C_2 are the lengths, in m, defined in Fig 1,

- support forces, in N:

$$F_{A3} = \frac{M_B}{l_{30}}$$

$$F_{A1} = C_R + F_{A3}$$

- maximum shear force in the rudder body, in N:

$$Q_R = C_R$$

1.2 Data for the direct calculation

1.2.1 Forces per unit length

The following forces per unit length are to be calculated, in N/m, according to [1.3]:

- p_R for spade rudders and rudders with solepiece (see Fig 1 and Fig 2, respectively),
- p_{R10} and p_{R20} for semi-spade rudders with rudder horn (see Fig 3).

1.2.2 Spring constant

The following support spring constants are to be calculated, in N/m, according to [1.4]:

- Z_C for rudders with solepiece (see Fig 2),
- Z_P for semi-spade rudders with rudder horn (see Fig 3).

1.3 Force per unit length on the rudder body

1.3.1 Spade rudders and 2 bearing rudders with solepiece

The force per unit length p_R (see Fig 1 and Fig 2) acting on the rudder body is to be obtained, in N/m, from the following formula:

$$p_R = \frac{C_R}{l_{10}}$$

1.3.2 2 bearing semi-spade rudders with rudder horn

The forces per unit length p_{R10} and p_{R20} (see Fig 1) acting on the rudder body are to be obtained, in N/m, from the following formulae:

$$p_{R10} = \frac{C_{R2}}{\ell_{10}}$$

$$p_{R20} = \frac{C_{R1}}{\ell_{20}}$$

1.4 Support spring constant

1.4.1 Sole piece

The spring constant Z_C for the support in the solepiece (see Fig 2) is to be obtained, in N/m, from the following formula:

$$Z_C = \frac{6180J_{50}}{\ell_{50}^3}$$

1.4.2 Rudder horn

The spring constant Z_P for the support in the rudder horn (see Fig 3) is to be obtained, in N/m, from the following formula:

$$Z_P = \frac{1}{f_B + f_T}$$

where:

f_B : unit displacement of rudder horn due to a unit force of 1 N acting in the centroid of the rudder horn, to be obtained, in m/N, from the following formula:

$$f_B = 1,3 \frac{d^3}{6180J_N}$$

d : height, in m, of the rudder horn, defined in Fig 3,

J_N : moment of inertia of rudder horn about the x axis, in cm^4 (see Fig 5),

f_T : unit displacement due to torsion to be obtained, in m/N, from the following formula:

$$f_T = 10^{-8} \frac{de^2}{3140F_T^2} \sum_i \frac{u_i}{t_i}$$

d, e : lengths, in m, defined in Fig 3

F_T : mean sectional area of rudder horn, in m^2 ,

u_i : length, in mm, of the individual plates forming the mean horn sectional area,

t_i : thickness of the individual plates mentioned above, in mm.

Figure 1 : Spade rudders

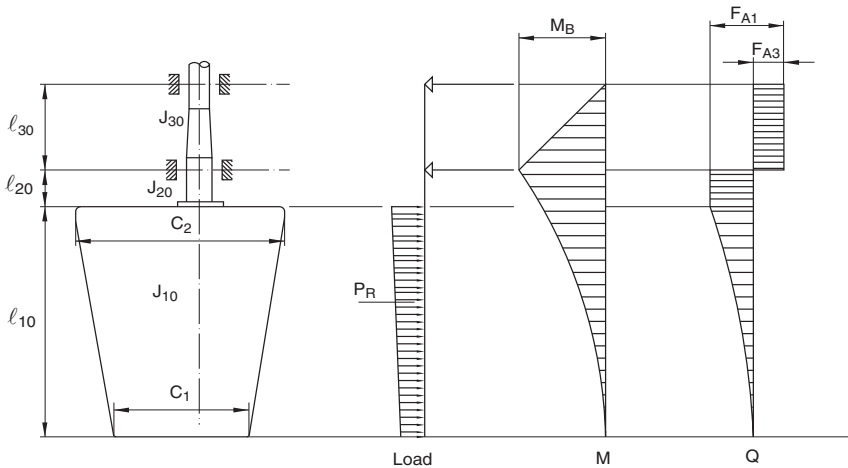

Figure 2 : 2 bearing rudders with solepiece

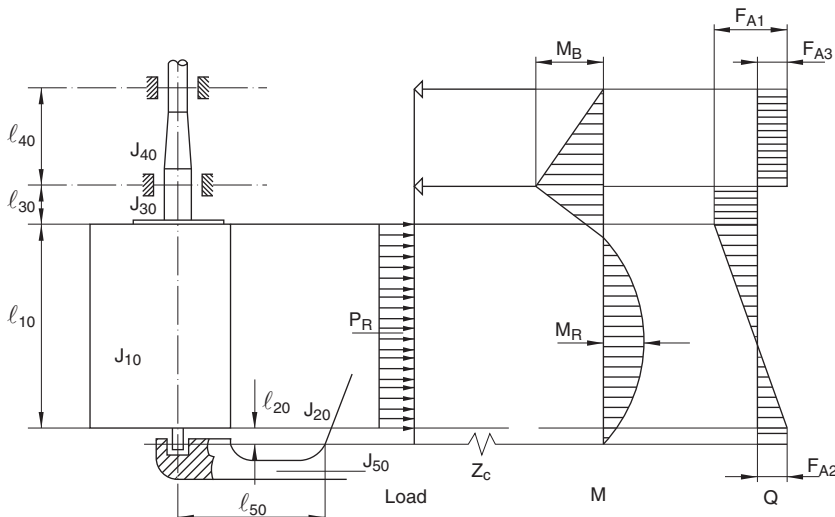

Figure 3 : 2 bearing semi-spade rudders with rudder horn

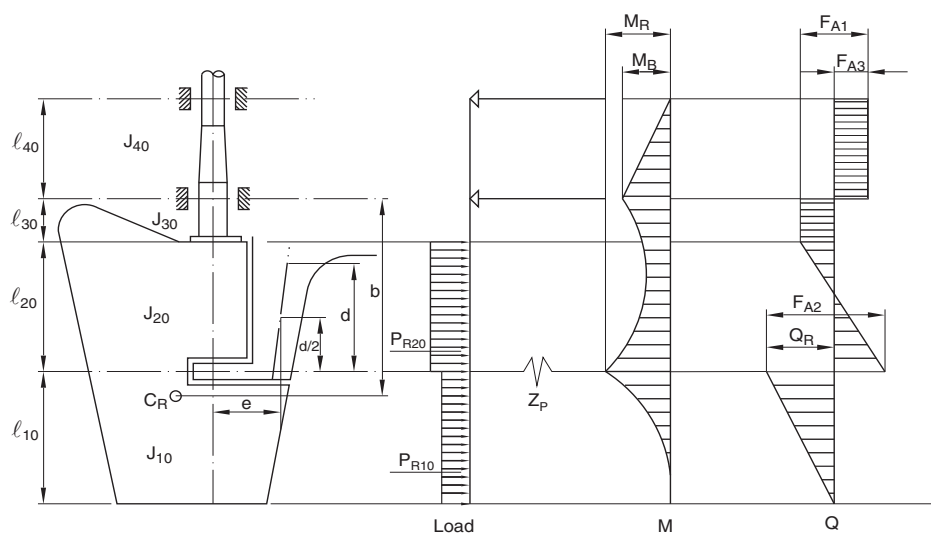

Figure 4 : Solepiece geometry

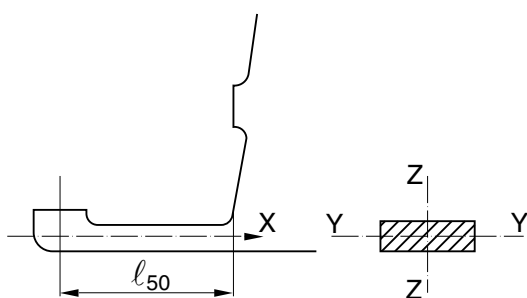
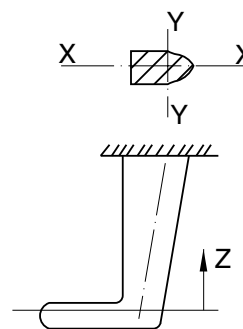

Figure 5 : Rudder horn geometry



Part B
Hull and Stability

Chapter 10

**CORROSION PROTECTION AND
LOADING INFORMATION**

SECTION 1 PROTECTION OF HULL METALLIC STRUCTURES

SECTION 2 LOADING MANUAL AND LOADING INSTRUMENTS

SECTION 1

PROTECTION OF HULL METALLIC STRUCTURES

1 Protection by coating

1.1 General

1.1.1 It is the responsibility of the shipbuilder and the Owner to choose the coating and have it applied in accordance with the manufacturer's requirements.

1.2 Structures to be protected

1.2.1 All salt water ballast spaces with boundaries formed by the hull envelope are to have a corrosion protective coating, epoxy or equivalent, applied in accordance with the manufacturer's requirements.

1.2.2 Corrosion protection of spaces other than ballast spaces is not a Class requirement.

1.2.3 Narrow spaces are generally to be filled by an efficient protective product, particularly at the ends of the ship where inspections and maintenance are not easily practicable due to their inaccessibility.

2 Cathodic protection

2.1 General

2.1.1 Internal structures in spaces intended to carry liquids may be provided with cathodic protection.

Cathodic protection may be fitted in addition to the required corrosion protective coating, if any.

2.1.2 Details concerning the type of anodes used and their location and attachment to the structure are to be submitted to the Society for approval.

2.2 Anodes

2.2.1 Magnesium or magnesium alloy anodes are not permitted in oil cargo tanks.

2.2.2 Aluminium anodes are only permitted in cargo tanks of tankers in locations where the potential energy does not exceed 28 kg m. The height of the anode is to be measured from the bottom of the tank to the centre of the anode, and its weight is to be taken as the weight of the anode as fitted, including the fitting devices and inserts.

However, where aluminium anodes are located on horizontal surfaces such as bulkhead girders and stringers not less than 1 m wide and fitted with an upstanding flange or face flat projecting not less than 75 mm above the horizontal surface, the height of the anode may be measured from this surface.

Aluminium anodes are not to be located under tank hatches or Butterworth openings, unless protected by the adjacent structure.

2.2.3 There is no restriction on the positioning of zinc anodes.

2.2.4 Anodes are to have steel cores and are to be declared by the Manufacturer as being sufficiently rigid to avoid resonance in the anode support and designed so that they retain the anode even when it is wasted.

2.2.5 The steel inserts are to be attached to the structure by means of a continuous weld. Alternatively, they may be attached to separate supports by bolting, provided a minimum of two bolts with lock nuts are used. However, other mechanical means of clamping may be accepted.

2.2.6 The supports at each end of an anode may not be attached to separate items which are likely to move independently.

2.2.7 Where anode inserts or supports are welded to the structure, they are to be arranged by the Shipyard so that the welds are clear of stress peaks.

2.3 Impressed current systems

2.3.1 Impressed current systems are not permitted in oil cargo tanks.

3 Protection against galvanic corrosion

3.1 General

3.1.1 Non-stainless steel is to be electrically insulated from stainless steel or from aluminium alloys.

3.1.2 Where stainless steel or aluminium alloys are fitted in the same tank as non-stainless steel, a protective coating is to cover both materials.

SECTION 2

LOADING MANUAL AND LOADING INSTRUMENTS

1 Definitions

1.1 Perpendiculars

1.1.1 Forward perpendicular

The forward perpendicular is the perpendicular to the waterline at the forward side of the stem on the summer load waterline

1.1.2 After perpendicular

The after perpendicular is the perpendicular to the waterline at the after side of the rudder post on the summer load waterline. For ships without rudder post, the after perpendicular is the perpendicular to the waterline at the centre of the rudder stock on the summer load waterline.

1.1.3 Midship perpendicular

The midship perpendicular is the perpendicular to the waterline at half the distance between forward and after perpendiculars.

2 Loading manual and loading instrument requirement criteria

2.1 General

2.1.1 The loading instrument is ship specific onboard equipment and the results of the calculations are only applicable to the ship for which it has been approved.

An approved loading instrument may not replace an approved loading manual.

3 Loading manual

3.1 Definitions

3.1.1 A loading manual is a document which describes:

- the loading conditions on which the design of the ship has been based, including permissible limits of still water bending moment and shear force
- the results of the calculations of still water bending moments, shear forces and, where applicable, limitations due to torsional and lateral loads
- the allowable local loading for the structure (hatch covers, decks, double bottom, etc.).

3.2 Conditions of approval

3.2.1 The approved loading manual is to be based on the final data of the ship. The manual is to include the design (full load and operational) loading conditions, subdivided into departure and arrival conditions as appropriate, upon

which the approval of the hull scantlings is based, defined in Ch 5, Sec 2, [2.1.2].

In the case of modifications resulting in changes to the main data of the ship, a new approved loading manual is to be issued.

3.2.2 Language

The loading manual is to be prepared in a language understood by the users. If this is not English, a translation into English is to be included.

4 Loading instrument

4.1 Definitions

4.1.1 A loading instrument is an instrument which is either analog or digital and by means of which it can be easily and quickly ascertained that, at specified read-out points, the still water bending moments, shear forces and still water torsional moments and lateral loads, where applicable, in any load or ballast condition, do not exceed the specified permissible values.

An operational manual is always to be provided for the loading instrument.

Single point loading instruments are not acceptable.

4.2 Conditions of approval

4.2.1 The loading instrument is subject to approval, which is to include:

- verification of type approval, if any
- verification that the final data of the ship have been used
- acceptance of number and position of all read-out points
- acceptance of relevant limits for read-out points
- checking of proper installation and operation of the instrument on board, under agreed test conditions, and that a copy of the operation manual is available.

4.2.2 In the case of modifications implying changes in the main data of the ship, the loading instrument is to be modified accordingly and approved.

4.2.3 The operation manual and the instrument output are to be prepared in a language understood by the users. If this is not English, a translation into English is to be included.

4.2.4 The operation of the loading instrument is to be verified upon installation under the agreed test condition. It is to be checked that the agreed test conditions and the operation manual for the instrument are available on board.

4.2.5 When the loading instrument also performs stability calculations, it is to be approved for stability purposes in accordance with the procedures indicated in [4.5] [4.6], as applicable.

4.3 Approval procedure

4.3.1 General

The loading instrument approval process includes the following procedures for each ship:

- data verification which results in endorsed test conditions
- approval of computer hardware, where necessary, as specified in Pt C, Ch 3, Sec 6, [2.4]
- installation testing which results in an Installation Test Report.

4.3.2 Data verification approval - Endorsed test conditions

The Society is to verify the results and actual ship data used by the calculation program for the particular ship on which the program will be installed.

Upon application for data verification, the Society is to advise the applicant of a minimum of four loading conditions, taken from the ship's approved loading manual, which are to be used as the test conditions. Within the range of these test conditions, each compartment is to be loaded at least once. The test conditions normally cover the range of load draughts from the deepest envisaged loaded condition to the light ballast condition. In addition, the lightship test condition is to be submitted.

When the loading instrument also performs stability calculations, the test conditions are to be taken from the ship's approved trim and stability booklet.

The data indicated in [4.3.3] and contained in the loading program are to be consistent with the data specified in the approved loading manual. Particular attention is drawn to the final lightship weight and centres of gravity derived from the inclining experiment or lightweight check.

The approval of the computer application software is based on the acceptance of the results of the test conditions according to [4.4], [4.5], and [4.6] as applicable.

When the requested information has been submitted and the results of the test conditions are considered satisfactory, the Society endorses the test conditions, a copy of which is to be available on board.

4.3.3 Data to be submitted

The following data, submitted by the applicant, are to be consistent with the as-built ship:

- identification of the calculation program including the version number
- main dimensions, hydrostatic particulars and, if applicable, ship profile
- position of the forward and after perpendiculars and, if appropriate, the calculation method to derive the for-

ward and after draughts at the actual position of the ship's draught marks

- ship lightweight and lightweight distribution along the ship's length
- lines plans and/or offset tables
- compartment definitions, including frame spacing and centre of volumes, together with capacity tables (sound-ing/ullage tables), if appropriate
- deadweight definitions for each loading condition.

4.3.4 Installation testing

During the installation test, one of the ship's senior officers is to operate the loading instrument and calculate the test conditions. This operation is to be witnessed by a Surveyor of the Society. The results obtained from the loading instrument are to be identical to those stated in the endorsed test conditions. If the numerical output from the loading instrument is different from the endorsed test conditions, no approval will be confirmed.

An installation test is also to be carried out on the second nominated computer, when applicable as indicated in Pt C, Ch 3, Sec 6, [2.4], which would be used in the event of failure of the first computer. Where the installation test is carried out on a type approved computer, a second nominated computer and test are not required.

Subject to the satisfactory completion of installation tests, the Society's Surveyor endorses the test conditions, adding details of the place and the date of the installation test survey, as well as the Society stamp and the Surveyor's signature.

4.3.5 Operational manual

A uniquely identified ship specific operational manual is to be submitted to the Society for documentation.

The operational manual is to be written in a concise and unambiguous manner. The use of illustrations and flow-charts is recommended.

The operational manual is to contain:

- a general description of the program denoting identification of the program and its stated version number
- details of the hardware specification needed to run the loading program
- a description of error messages and warnings likely to be encountered, and unambiguous instructions for subsequent actions to be taken by the user in each case
- where applicable, the shear force correction factors
- where applicable, the local permissible limits for single and two adjacent hold loadings as a function of the appropriate draught and the maximum weight for each hold
- where applicable, the Society's restrictions (maximum allowable load on double bottom, maximum specific gravity allowed in liquid cargo tanks, maximum filling level or percentage in liquid cargo tanks)
- example of a calculation procedure supported by illustrations and sample computer output
- example computer output of each screen display, complete with explanatory text.

4.3.6 Calculation program specifications

The software is to be written so as to ensure that the user cannot alter the critical ship data files containing the following information:

- lightship weight and lightship weight distribution and associated centres of gravity
- the Society’s structural limitations or restrictions
- geometric hull form data
- hydrostatic data and cross curves, where applicable
- compartment definitions, including frame spacing and centre of volumes, together with capacity tables (sounding/ullage tables), if appropriate.

Any changes in the software are to be made by the manufacturer or his appointed representative and the Society is to be informed immediately of such changes. Failure to advise of any modifications to the calculation program may invalidate the approval issued. In cases where the approval is considered invalid by the Society, the modified calculation program is to be re-assessed in accordance with the approval procedure.

4.3.7 Functional specification

The calculation program is to be user-friendly and designed such that it limits possible input errors by the user.

The forward, midship and after draughts, at the respective perpendiculars, are to be calculated and presented to the user on screen and hardcopy output in a clear and unambiguous manner.

It is recommended that the forward, midship and after draughts, at the actual position of the ship’s draught marks are calculated and presented to the user on screen and hardcopy output in a clear and unambiguous manner.

The displacement is to be calculated for the specified loading condition and corresponding draught readings and presented to the user on screen and hardcopy output.

The loading instrument is to be capable of producing print-outs of the results in both numerical and graphical forms. The numerical values are to be given in both forms, as absolute values and as the percentage of the permissible values. This print-out is to include a description of the corresponding loading condition.

All screen and hardcopy output data is to be presented in a clear and unambiguous manner with an identification of the calculation program (the version number is to be stated).

4.4 Hull girder forces and moments

4.4.1 General

The loading program is to be capable of calculating the following hull girder forces and moments in accordance with Ch 5, Sec 2, [2]:

- Still Water Shear Force (SWSF) including the shear force correction, where applicable
- Still Water Bending Moment (SWBM)

The data which are to be provided to or accepted by the Society are specified in Tab 1.

Read-out points are usually to be selected at the position of the transverse bulkheads or other obvious boundaries.

The calculated forces and moments are to be displayed in both graphical and tabular formats, including the percentage of permissible values. The screen and hardcopy output is to display the calculated forces or moments, and the corresponding permissible limits, at each specified read-out point. Alternative limits may be considered by the Society on a case by case basis.

4.4.2 Acceptable tolerances

The accuracy of the calculation program is to be within the acceptable tolerance band, specified in Tab 1, of the results at each read-out point obtained by the Society, using an independent program or the approved loading manual with identical input.

Table 1 : Data to be provided to/or accepted by the Society

Calculation	Data to be provided to or accepted by the Society
Still Water Shear Force (SWSF)	<ul style="list-style-type: none"> • The read-out points (frame locations) for the SWSF calculations. These points are normally selected at the position of the transverse bulkhead or other obvious boundaries. Additional read-out points may be specified between the bulkheads of long holds or tanks or between container stacks. • Shear force correction factors and method of application. • The permissible seagoing and harbour SWSF limits at the read-out points. Where appropriate, additional sets of permissible SWSF values may be specified.
Still Water Bending Moment (SWBM)	<ul style="list-style-type: none"> • The read-out points (frame locations) for the SWBM calculations. These points are normally selected at the position of the transverse bulkhead, mid-hold or other obvious boundaries. • The permissible seagoing and harbour SWBM limits at the read-out points. Where appropriate, additional sets of permissible SWBM values may be specified.

Table 2 : Tolerance band for the comparison of computational accuracy

Computation	Tolerance (percentage of the permissible values)
Still Water Shear Force	± 5%
Still Water Bending Moment	± 5%

4.4.3 Permissible limits and restrictions

The user is to be able to view the following Society structural limitations in a clear and unambiguous manner:

- all permissible still water shear forces and still water bending moments
- cargo hold weight
- ballast tank/hold capacities
- filling restrictions.

It is to be readily apparent to the user when any of the structural limits has been exceeded.

4.5 Intact stability**4.5.1 Application**

The loading instrument approval for stability purposes is required when a loading instrument to be installed on board a ship performs stability calculations, as stated in [4.2.5].

4.5.2 Data verification approval - Endorsed test conditions

The requirements in [4.3.2] apply. In addition, at least one of the four loading conditions required is to show the compartments, intended for liquid loads in which the free surface effect is considerable, filled in order to have the maximum free surface moment.

The additional data necessary for the approval of the loading instrument for stability purposes are specified in [4.5.3].

In order to obtain the approval of the loading instrument, all the intact stability requirements (and relevant criteria) applicable to the ship, reported in Ch 3, Sec 2 as well as in [4.5.2], are to be available in the computer output; the lack of any one of them is sufficient to prevent the endorsement of the test conditions.

4.5.3 Additional data to be submitted

In addition to the data required in [4.3.3], the following are to be submitted:

- cross curves of stability calculated on a free trimming basis, for the ranges of displacement and trim anticipated in normal operating conditions, with indication of the volumes which have been considered in the computation of these curves,
- capacity tables indicating, for each compartment or space, the values of the co-ordinates X_G , Y_G and Z_G of

the centre of gravity, as well as the inertia, corresponding to an adequate number of filling percentages

- list of all the openings (location, tightness, means of closure), pipes or other sources which may lead to progressive flooding
- deadweight definitions for each loading condition in which, for any load taken into account, the following information is to be specified:
 - weight and centre of gravity co-ordinates
 - percentage of filling (if liquid load)
 - free surface moment (if liquid load)
- information on loading restrictions (maximum filling level or percentage in liquid cargo tanks, maximum KG or minimum GM curve or table which can be used to determine compliance with the applicable intact and damage stability criteria), when applicable
- all the intact stability criteria applicable to the ship concerned.

4.6 Damage stability**4.6.1 Application**

The loading instrument approval for stability purposes is required when a loading instrument to be installed on board a ship performs damage stability calculations, as stated in [4.2.5].

In such case, the loading instrument is also to perform intact stability calculations, and therefore the approval is to be based on the requirements specified in [4.5].

Additional requirements relevant to damage stability are given in [4.6.2] and [4.6.3].

4.6.2 Data verification approval - Endorsed test conditions

The requirements specified in [4.5.2] apply.

The additional data necessary for the approval of the loading instrument for stability purposes are specified in [4.6.3].

4.6.3 Additional data to be submitted

In addition to the data required in [4.5.3], the following are to be submitted:

- list of all the damage cases which are to be considered in accordance with the relevant deterministic damage stability rules. Each damage case is to clearly indicate all the compartments or spaces taken into account, as well as the permeability associated with each compartment or space.

This information is to be taken from the approved damage stability documentation, and the source details are to be clearly indicated; in the case of unavailability of such documentation, the above-mentioned information may be requested from the Society.

- all the damage stability criteria applicable to the ship concerned.

CONSTRUCTION AND TESTING

SECTION 1	WELDING AND WELD CONNECTIONS
SECTION 2	SPECIAL STRUCTURAL DETAILS
SECTION 3	TESTING
APPENDIX 1	WELDING DETAILS
APPENDIX 2	REFERENCE SHEETS FOR SPECIAL STRUCTURAL DETAILS

SECTION 1

WELDING AND WELD CONNECTIONS

1 General

1.1 Application

1.1.1 The requirements of this Section apply for the preparation, execution and inspection of welded connections in hull structures.

They are to be complemented by the criteria given in App 1, to which reference is made. These criteria being given as recommendations, minor departures may be accepted by the Society, on a case by case basis.

The general requirements relevant to fabrication by welding and qualification of welding procedures are given in Part D, Chapter 5 of the Rules for the Classification of the Ships.

1.1.2 Weld connections are to be executed according to the approved plans. Any detail not specifically represented in the plans is, if any, to comply with the applicable requirements.

1.1.3 It is understood that welding of the various types of steel is to be carried out by means of welding procedures approved for the purpose, even though an explicit indication to this effect may not appear on the approved plans.

1.1.4 The quality standard adopted by the shipyard is to be submitted to the Society and applies to all constructions unless otherwise specified on a case by case basis.

1.2 Base material

1.2.1 The requirements of this Section apply for the welding of hull structural steels or aluminium alloys of the types considered in Part D of the Rules for the Classification of the Ships or other types accepted as equivalent by the Society.

1.2.2 The service temperature is intended to be the ambient temperature, unless otherwise stated.

1.3 Welding consumables and procedures

1.3.1 Approval of welding consumables and procedures

Welding consumables and welding procedures adopted are to be approved by the Society.

The requirements for the approval of welding consumables are given in Part D, Ch 5, Sec 2 of the Rules for the Classification of the Ships.

The requirements for the approval of welding procedures for the individual users are given in Part D, Ch 5, Sec 4 and Part D, Ch 5, Sec 5 of the Rules for the Classification of the Ships.

1.3.2 Consumables

For welding of hull structural steels, the minimum consumable grades to be adopted are specified in Tab 1 depending on the steel grade.

Consumables used for manual or semi-automatic welding (covered electrodes, flux-cored and flux-coated wires) of higher strength hull structural steels are to be at least of hydrogen-controlled grade H15 (H). Where the carbon equivalent C_{eq} is not more than 0,41% and the thickness is below 30 mm, any type of approved higher strength consumables may be used at the discretion of the Society.

Especially, welding consumables with hydrogen-controlled grade H15 (H) and H10 (HH) shall be used for welding hull steel forgings and castings of respectively ordinary strength level and higher strength level.

Table 1 : Consumable grades

Steel grade	Consumable minimum grade	
	Butt welding, partial and full T penetration welding	Fillet welding
A	1	1
B - D	2	
E	3	
AH32 - AH36 DH32 - DH36	2Y	2Y
EH32 - EH36	3Y	
FH32 - FH36	4Y	
AH40	2Y40	2Y40
DH40 - EH40	3Y40	
FH40	4Y40	

Note 1:

Welding consumables approved for welding higher strength steels (Y) may be used in lieu of those approved for welding normal strength steels having the same or a lower grade; welding consumables approved in grade Y40 may be used in lieu of those approved in grade Y having the same or a lower grade.

Note 2:

In the case of welded connections between two hull structural steels of different grades, as regards strength or notch toughness, welding consumables appropriate to one or the other steel are to be adopted.

1.4 Personnel and equipment

1.4.1 Welders

Manual and semi-automatic welding is to be performed by welders certified by the Society in accordance with recognized standards (see Part D, Ch 5, Sec 1, [2.2.3] and Part D, Ch 5, Sec 1, [2.2.5] of the Rules for the Classification of the Ships); the welders are to be employed within the limits of their respective approval.

1.4.2 Automatic welding operators

Personnel manning automatic welding machines and equipment are to be competent and sufficiently trained.

1.4.3 Organisation

The internal organisation of the shipyard is to be such as to ensure compliance in full with the requirements in [1.4.1] and [1.4.2] and to provide for assistance and inspection of welding personnel, as necessary, by means of a suitable number of competent supervisors.

1.4.4 NDE operators

Non-destructive tests are to be carried out by operators qualified according to the requirements of Part D, Ch 1, Sec 1, [3.6.4] of the Rules for the Classification of the Ships.

The qualifications are to be appropriate to the specific applications.

1.4.5 Technical equipment and facilities

The welding equipment is to be appropriate to the adopted welding procedures, of adequate output power and such as to provide for stability of the arc in the different welding positions.

In particular, the welding equipment for special welding procedures is to be provided with adequate and duly calibrated measuring instruments, enabling easy and accurate reading, and adequate devices for easy regulation and regular feed.

Manual electrodes, wires and fluxes are to be stored in suitable locations so as to ensuring their preservation in proper condition. Especially, where consumables with hydrogen-controlled grade are to be used, proper precautions are to be taken to ensure that manufacturer's instructions are followed to obtain (drying) and maintain (storage, maximum time exposed, re-backing, ...) hydrogen-controlled grade.

1.5 Documentation to be submitted

1.5.1 The structural plans to be submitted for approval, according to Ch 1, Sec 3, are to contain the necessary data relevant to the fabrication by welding of the structures and items represented as far as class is concerned.

For important structures, the main sequences of prefabrication, assembly and welding and non-destructive examination planned are also to be represented in the plans.

1.5.2 A plan showing the location of the various steel types is to be submitted at least for outer shell, deck and bulkhead structures.

1.6 Design

1.6.1 General

For the various structural details typical of welded construction in shipbuilding and not dealt with in this Section, the rules of good practice, recognised standards and past experience are to apply as agreed by the Society.

1.6.2 Plate orientation

The plates of the shell and strength deck are generally to be arranged with their length in the fore-aft direction. Possible exceptions to the above will be considered by the Society on a case by case basis; tests as deemed necessary (for example, transverse impact tests) may be required by the Society.

1.6.3 Overall arrangement

Particular consideration is to be given to the overall arrangement and structural details of highly stressed parts of the hull.

Plans relevant to the special details specified in Sec 2 are to be submitted.

1.6.4 Prefabrication sequences

Prefabrication sequences are to be arranged so as to facilitate positioning and assembling as far as possible.

The amount of welding to be performed on board is to be limited to a minimum and restricted to easily accessible connections.

1.6.5 Distance between welds

Welds located too close to one another are to be avoided. The minimum distance between two adjacent welds is considered on a case by case basis, taking into account the level of stresses acting on the connected elements.

In general, the distance between two adjacent butts in the same strake of shell or deck plating is to be greater than two frame spaces.

2 Type of connections and preparation

2.1 General

2.1.1 The type of connection and the edge preparation are to be appropriate to the welding procedure adopted, the structural elements to be connected and the stresses to which they are subjected.

2.2 Butt welding

2.2.1 General

In general, butt connections of plating are to be full penetration, welded on both sides except where special procedures or specific techniques, considered equivalent by the Society, are adopted.

Connections different from the above may be accepted by the Society on a case by case basis; in such cases, the relevant detail and workmanship specifications are to be approved.

2.2.2 Welding of plates with different thicknesses

In the case of welding of plates with a difference in gross thickness equal to or greater than:

- 3 mm, if the thinner plate has a gross thickness equal to or less than 10 mm
- 4 mm, if the thinner plate has a gross thickness greater than 10 mm,

a taper having a length of not less than 4 times the difference in gross thickness is to be adopted for connections of plating perpendicular to the direction of main stresses. For connections of plating parallel to the direction of main stresses, the taper length may be reduced to 3 times the difference in gross thickness.

When the difference in thickness is less than the above values, it may be accommodated in the weld transition between plates.

2.2.3 Edge preparation, root gap

Typical edge preparations and gaps are indicated in App 1, [1.2].

The acceptable root gap is to be in accordance with the adopted welding procedure and relevant bevel preparation.

2.2.4 Butt welding on permanent backing

Butt welding on permanent backing, i.e. butt welding assembly of two plates backed by the flange or the face plate of a stiffener, may be accepted where back welding is not feasible or in specific cases deemed acceptable by the Society.

The type of bevel and the gap between the members to be assembled are to be such as to ensure a proper penetration of the weld on its backing and an adequate connection to the stiffener as required.

2.2.5 Section, bulbs and flat bars

When lengths of longitudinals of the shell plating and strength deck within 0,6 L amidships, or elements in general subject to high stresses, are to be connected together by butt joints, these are to be full penetration. Other solutions may be adopted if deemed acceptable by the Society on a case by case basis.

The work is to be done in accordance with an approved procedure; in particular, this requirement applies to work done on board or in conditions of difficult access to the welded connection. Special measures may be required by the Society.

2.3 Fillet welding

2.3.1 General

In general, ordinary fillet welding (without bevel) may be adopted for T connections of the various simple and composite structural elements, where they are subjected to low stresses (in general not exceeding 30 N/mm²) and adequate precautions are taken to prevent the possibility of local laminations of the element against which the T web is welded.

Where this is not the case, partial or full T penetration welding according to [2.4] is to be adopted.

2.3.2 Fillet welding types

Fillet welding may be of the following types:

- continuous fillet welding, where the weld is constituted by a continuous fillet on each side of the abutting plate (see [2.3.3])
- intermittent fillet welding, which may be subdivided (see [2.3.4]) into:
 - chain welding
 - scallop welding
 - staggered welding.

2.3.3 Continuous fillet welding

Continuous fillet welding is to be adopted:

- for watertight connections
- for connections of brackets, lugs and scallops
- at the ends of connections for a length of at least 75mm
- where intermittent welding is not allowed, according to [2.3.4].

Continuous fillet welding may also be adopted in lieu of intermittent welding wherever deemed suitable, and it is recommended where the spacing p , calculated according to [2.3.4], is low.

2.3.4 Intermittent welding

The spacing p and the length d , in mm, of an intermittent weld, shown in:

- Fig 1, for chain welding
- Fig 2, for scallop welding
- Fig 3, for staggered welding

are to be such that:

$$\frac{p}{d} \leq \phi$$

where the coefficient ϕ is defined in Tab 2 and Tab 3 for the different types of intermittent welding, depending on the type and location of the connection.

In general, staggered welding is not allowed for connections subjected to high alternate stresses.

In addition, the following limitations are to be complied with:

- chain welding (see Fig 1):
 - $d \geq 75$ mm
 - $p-d \leq 200$ mm

Figure 1 : Intermittent chain welding

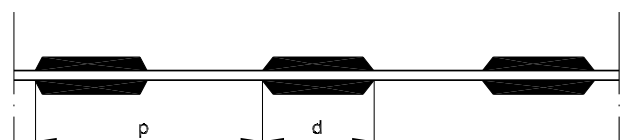

- scallop welding (see Fig 2):
 - $d \geq 75$ mm
 - $p-d \leq 150$ mm
 - $v \leq 0,25b$, without being greater than 75 mm

Figure 2 : Intermittent scallop welding

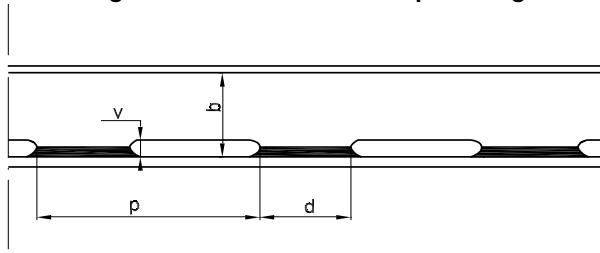

- staggered welding (see Fig 3):
 $d \geq 75$ mm
 $p - 2d \leq 300$ mm
 $p \leq 2d$ for connections subjected to high alternate stresses.

Figure 3 : Intermittent staggered welding

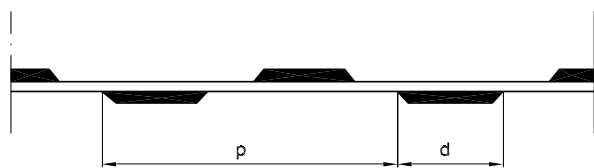

2.3.5 Throat thickness of fillet weld T connections

The throat thickness of fillet weld T connections is to be obtained, in mm, from the following formula:

$$t_T = w_F t \frac{p}{d}$$

where:

- w_F : Welding factor, defined in Tab 2 for the various hull structural connections; for connections of primary supporting members belonging to single skin structures and not mentioned in Tab 2, w_F is defined in Tab 3;
- t : Actual gross thickness, in mm, of the structural element which constitutes the web of the T connection
- p, d : Spacing and length, in mm, of an intermittent weld, defined in [2.3.4].

Figure 4 : Continuous fillet welding between cut-outs

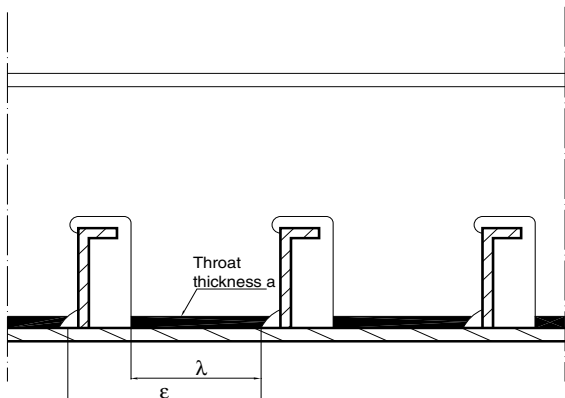

For continuous fillet welds, p/d is to be taken equal to 1.

In no case may the throat thickness be less than:

- 3,0 mm, where the gross thickness of the thinner plate is less than 6 mm
- 3,5 mm, otherwise.

The throat thickness may be required by the Society to be increased, depending on the results of structural analyses.

The leg length of fillet weld T connections is to be not less than 1,4 times the required throat thickness.

2.3.6 Weld dimensions in a specific case

Where intermittent fillet welding is adopted with:

- length $d = 75$ mm
- throat thickness t_T specified in Tab 4 depending on the thickness t defined in [2.3.5]

the weld spacing may be taken equal to the value p_1 defined in Tab 1. The values of p_1 in Tab 1 may be used when $8 \leq t \leq 16$ mm.

For thicknesses t less than 8 mm, the values of p_1 may be increased, with respect to those in Tab 2, by:

- 10 mm for chain or scallop welding
- 20 mm for staggered welding

without exceeding the limits in [2.3.4].

For thicknesses t greater than 16 mm, the values of p_1 are to be reduced, with respect to those in Tab 2, by:

- 10 mm for chain or scallop welding
- 20 mm for staggered welding.

Figure 5 : Intermittent scallop fillet welding between cut-outs

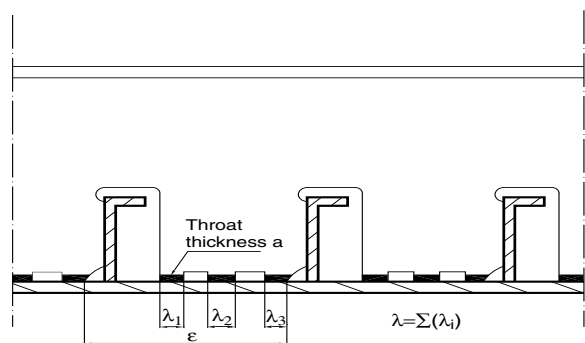

Table 2 : Welding factors w_F and coefficient ϕ for the various hull structural connections (1/1/2017)

Hull area	Connection		w_F (1)	ϕ (2) (3)			p_1 , in mm (see [2.3.6]) (3)	
	of	to		CH	SC	ST		
General, unless otherwise specified in the table	watertight plates	boundaries	0,35					
	webs of ordinary stiffeners	plating	0,13	3,5	3,0	4,6	ST 260	
		face plate of fabricated stiffeners	at ends (4)	0,13				
			elsewhere	0,13	3,5	3,0	4,6	ST 260
Bottom and double bottom	longitudinal ordinary stiffeners	bottom and inner bottom plating	0,13	3,5	3,0	4,6	ST 260	
	centre girder	keel	0,25	1,8	1,8		CH/SC 130	
		inner bottom plating	0,20	2,2	2,2		CH/SC 160	
	side girders	bottom and inner bottom plating	0,13	3,5	3,0	4,6	ST 260	
		floors (interrupted girders)	0,20	2,2			CH 160	
	floors	bottom and inner bottom plating	in general	0,13	3,5	3,0	4,6	ST 260
			at ends (20% of span) for longitudinally framed double bottom	0,25	1,8			CH 130
		inner bottom plating in way of brackets of primary supporting members	0,25	1,8			CH 130	
		girders (interrupted floors)	0,20	2,2			CH 160	
		side girders in way of hopper tanks	0,35					
	partial side girders	floors	0,25	1,8			CH 130	
web stiffeners	floor and girder webs	0,13	3,5	3,0	4,6	ST 260		
Side and inner side	ordinary stiffeners	side and inner side plating	0,13	3,5	3,0	4,6	ST 260	
	girders in double side skin ships	side and inner side plating	0,35					
Deck	strength deck	side plating	Partial penetration welding					
	non-watertight decks	side plating	0,20	2,2			CH 160	
	ordinary stiffeners and intercostal girders	deck plating	0,13	3,5	3,0	4,6	ST 260	
	hatch coamings	deck plating	in general	0,35				
			at corners of hatchways for 15% of the hatch length	0,45				
web stiffeners	coaming webs	0,13	3,5	3,0	4,6	ST 260		

Hull area	Connection			w_F (1)	ϕ (2) (3)			p_1 , in mm (see [2.3.6]) (3)
	of	to			CH	SC	ST	
Bulkheads	tank bulkhead structures	tank bottom	plating and ordinary stiffeners (plane bulkheads)	0,45				
			boundaries other than tank bottom		0,35			
	watertight bulkhead structures	boundaries		0,35				
	non-watertight bulkhead structures	boundaries	wash bulkheads	0,20	2,2	2,2		CH/SC 160
			others	0,13	3,5	3,0	4,6	ST 260
	ordinary stiffeners	bulkhead plating	in general (5)	0,13	3,5	3,0	4,6	ST 260
at ends (25% of span), where no end brackets are fitted			0,35					
Structures located forward of 0,75 L from the AE (6)	bottom longitudinal ordinary stiffeners	bottom plating		0,20	2,2			CH 160
	floors and girders	bottom and inner bottom plating		0,25	1,8			CH 130
	side frames in panting area	side plating		0,20	2,2			CH 160
	webs of side girders in single side skin structures	side plating and face plate	$A < 65 \text{ cm}^2$ (7)	0,25	1,8	1,8		CH/SC 130
			$A \geq 65 \text{ cm}^2$ (7)	See Tab 3				
After peak (6)	internal structures	each other		0,20				
	side ordinary stiffeners	side plating		0,20				
	floors	bottom and inner bottom plating		0,20				
Machinery space (6)	centre girder	keel and inner bottom plating	in way of main engine foundations	0,45				
			in way of seating of auxiliary machinery and boilers	0,35				
			elsewhere	0,25	1,8	1,8		CH/SC 130
	side girders	bottom and inner bottom plating	in way of main engine foundations	0,45				
			in way of seating of auxiliary machinery and boilers	0,35				
			elsewhere	0,20	2,2	2,2		CH/SC 160
	floors (except in way of main engine foundations)	bottom and inner bottom plating	in way of seating of auxiliary machinery and boilers	0,35				
			elsewhere	0,20	2,2	2,2		CH/SC 160
	floors in way of main engine foundations	bottom plating		0,35				
		foundation plates		0,45				
	floors	centre girder	single bottom	0,45				
			double bottom	0,25	1,8	1,8		CH/SC 130

Hull area	Connection			w_F (1)	ϕ (2) (3)			p_1 , in mm (see [2.3.6]) (3)
	of	to			CH	SC	ST	
Superstructures and deckhouses	external bulkheads	deck	in general	0,35				
			engine and boiler casings at corners of openings (15% of opening length)	0,45				
	internal bulkheads	deck		0,13	3,5	3,0	4,6	ST 260
	ordinary stiffeners	external and internal bulkhead plating		0,13	3,5	3,0	4,6	ST 260
Hatch covers	ordinary stiffener	plating		0,13	3,5	3,0	4,6	ST 260
Pillars	elements composing the pillar section	each other (fabricated pillars)		0,13				
	pillars	deck	pillars in compression	0,35				
			pillars in tension	Full penetration welding				
Ventilators	coamings	deck		0,35				
Rudders	horizontal and vertical webs directly connected to solid parts	each other		0,45				
		plating		0,35				
	other webs	each other		0,20		2,2		SC 160
	webs	plating	in general	0,20		2,2		SC 160
			top and bottom plates of rudder plating	0,35				
	solid parts or rudder stock		According to Ch 9, Sec 1, [7.4] or Ch 9, Sec 1, [7.5]					

(1) In connections for which $w_F \geq 0,35$, continuous fillet welding is to be adopted.
(2) For coefficient ϕ , see [2.3.4]. In connections for which no ϕ value is specified for a certain type of intermittent welding, such type is not permitted and continuous welding is to be adopted.
(3) CH = chain welding, SC = scallop welding, ST = staggered welding.
(4) Ends of ordinary stiffeners means the area extended 75 mm from the span ends. Where end brackets are fitted, ends means the area extended in way of brackets and at least 50 mm beyond the bracket toes.
(5) In tanks intended for the carriage of ballast or fresh water, continuous welding with $w_F = 0,35$ is to be adopted.
(6) For connections not mentioned, the requirements for the central part apply.
(7) A is the face plate sectional area of the side girders, in cm^2 .

2.3.7 Throat thickness of welds between cut-outs

The throat thickness of the welds between the cut-outs in primary supporting member webs for the passage of ordinary stiffeners is to be not less than the value obtained, in mm, from the following formula:

$$t_{TC} = t_T \frac{\epsilon}{\lambda}$$

where:

- t_T : Throat thickness defined in [2.3.5]
 ϵ, λ : Dimensions, in mm, to be taken as shown in:
- Fig 4, for continuous welding
 - Fig 5, for intermittent scallop welding.

2.3.8 Throat thickness of welds connecting ordinary stiffeners with primary supporting members

The throat thickness of fillet welds connecting ordinary stiffeners and collar plates, if any, to the web of primary supporting members is to be not less than $0,35t_w$, where t_w is the web gross thickness, in mm. Further requirements are specified in Sec 2.

Where primary supporting member web stiffeners are welded to ordinary stiffener face plates, in certain cases the Society may require the above throat thickness to be obtained, in mm, from the following formula:

$$t_T = \frac{4(p_S + p_W)s\ell\left(1 - \frac{s}{2\ell}\right)}{u + v\left(\frac{c + 0,2d}{b + 0,2d}\right)}$$

where:

p_s, p_w : Still water and wave pressure, respectively, in kN/m^2 , acting on the ordinary stiffener, defined in Ch 7, Sec 2, [3.3.2]

b, c, d, u, v : Main dimensions, in mm, of the cut-out shown in Fig 6.

Table 3 : Welding factors w_F and coefficient ϕ for connections of primary supporting members

Primary supporting member	Connection		w_F (1)	ϕ (2) (3)			p_1 , in mm (see [2.3.6]) (3)
	of	to		CH	SC	ST	
General (4)	web, where $A < 65 \text{ cm}^2$	plating and face plate	at ends	0,20			
			elsewhere	0,15	3,0	3,0	CH/SC 210
	web, where $A \geq 65 \text{ cm}^2$	plating	at ends	0,35			
			elsewhere	0,25	1,8	1,8	CH/SC 130
end brackets	face plate		0,35				
In tanks, where $A < 65 \text{ cm}^2$ (5)	web	plating	at ends	0,25			
			elsewhere	0,20	2,2	2,2	CH/SC 160
	web	face plate	at ends	0,20			
			elsewhere	0,15	3,0	3,0	CH/SC 210
end brackets	face plate		0,35				
In tanks, where $A \geq 65 \text{ cm}^2$	web	plating	at ends	0,45			
			elsewhere	0,35			
	web	face plate	at ends	0,35			
			elsewhere	0,45			
end brackets	face plate		0,45				

- (1) In connections for which $w_F \geq 0,35$, continuous fillet welding is to be adopted.
- (2) For coefficient ϕ , see [2.3.4]. In connections for which no ϕ value is specified for a certain type of intermittent welding, such type is not permitted.
- (3) CH = chain welding, SC = scallop welding, ST = staggered welding.
- (4) For cantilever deck beams, continuous welding is to be adopted.
- (5) For primary supporting members in tanks intended for the carriage of ballast or fresh water, continuous welding is to be adopted.

Note 1:

A is the face plate sectional area of the primary supporting member, in cm^2 .

Note 2:

Ends of primary supporting members means the area extended 20% of the span from the span ends. Where end brackets are fitted, ends means the area extended in way of brackets and at least 100 mm beyond the bracket toes.

**Figure 6 : End connection of ordinary stiffener
Dimensions of the cut-out**

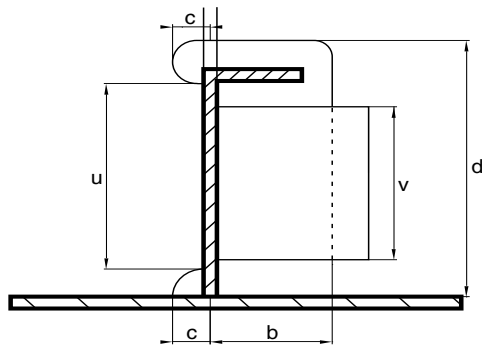

Table 4 : Required throat thickness

t, in mm	t _r , in mm	t, in mm	t _r , in mm
6	3,0	17	7,0
8	3,5	18	7,0
9	4,0	19	7,5
10	4,5	20	7,5
11	5,0	21	8,5
12	5,5	22	8,5
13	6,0	23	9,0
14	6,0	24	9,0
15	6,5	25	10,0
16	6,5	26	10,0

2.3.9 Throat thickness of deep penetration fillet welding

When fillet welding is carried out with automatic welding procedures, the throat thickness required in [2.3.5] may be reduced up to 15%, depending on the properties of the electrodes and consumables. However, this reduction may not be greater than 1,5 mm.

The same reduction applies also for semi-automatic procedures where the welding is carried out in the downhand position.

2.4 Partial and full T penetration welding

2.4.1 General

Partial or full T penetration welding is to be adopted for connections subjected to high stresses for which fillet welding is considered unacceptable by the Society.

Partial or full T penetration welding is required, depending on the ship type. Further requirements are specified in Sec 2.

Typical edge preparations are indicated in:

- for partial penetration welds: Fig 7 and Fig 8, in which f , in mm, is to be taken between 3 mm and $t/3$, and α between 45° and 60°
- for full penetration welds: Fig 9 and Fig 10, in which f , in mm, is to be taken between 0 and 3 mm, and α between 45° and 60°

Back gouging is generally required for full penetration welds.

2.4.2 Lamellar tearing

Precautions are to be taken in order to avoid lamellar tears, which may be associated with:

- cold cracking when performing T connections between plates of considerable thickness or high restraint
- large fillet welding and full penetration welding on higher strength steels.

2.5 Lap-joint welding

2.5.1 General

Lap-joint welding may be adopted for:

- peripheral connection of doublers
- internal structural elements subjected to very low stresses.

Elsewhere, lap-joint welding may be allowed by the Society on a case by case basis, if deemed necessary under specific conditions.

Continuous welding is generally to be adopted.

2.5.2 Gap

The surfaces of lap-joints are to be in sufficiently close contact.

2.5.3 Dimensions

The dimensions of the lap-joint are to be specified and are considered on a case by case basis. Typical details are given in App 1, [1.3].

Figure 7 : Partial penetration weld

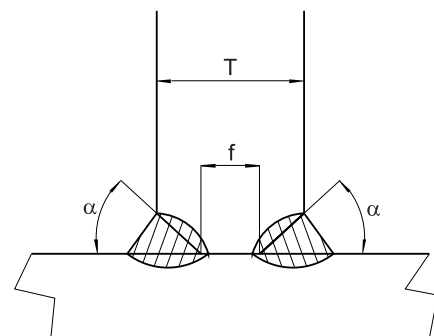

Figure 8 : Partial penetration weld

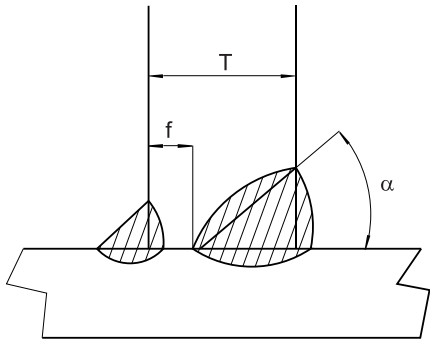

Figure 9 : Full penetration weld

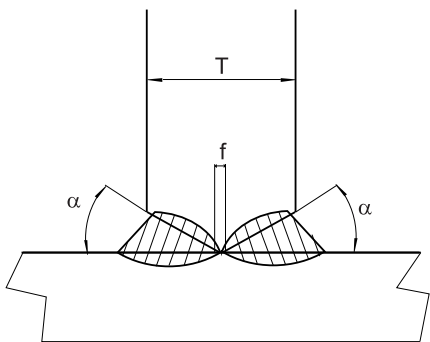
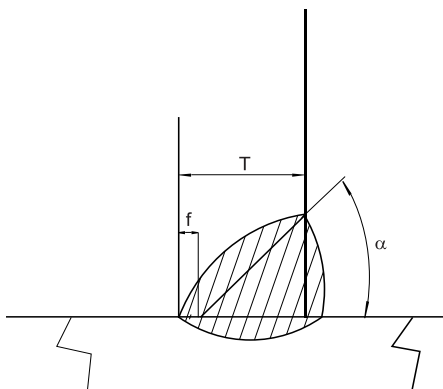

Figure 10 : Full penetration weld



2.6 Slot welding

2.6.1 General

Slot welding may be adopted in very specific cases subject to the special agreement of the Society, e.g. for doublers according to Ch 4, Sec 3, [2.1].

In general, slot welding of doublers on the outer shell and strength deck is not permitted within 0,6L amidships. Beyond this zone, slot welding may be accepted by the Society on a case by case basis.

Slot welding is, in general, permitted only where stresses act in a predominant direction. Slot welds are, as far as possible, to be aligned in this direction.

2.6.2 Dimensions

Slot welds are to be of appropriate shape (in general oval) and dimensions, depending on the plate thickness, and may not be completely filled by the weld.

Typical dimensions of the slot weld and the throat thickness of the fillet weld are given in App 1.

The distance between two consecutive slot welds is to be not greater than a value which is defined on a case by case basis taking into account:

- the transverse spacing between adjacent slot weld lines
- the stresses acting in the connected plates
- the structural arrangement below the connected plates.

2.7 Plug welding

2.7.1 Plug welding may be adopted only when accepted by the Society on a case by case basis, according to specifically defined criteria. Typical details are given in App 1.

3 Specific weld connections

3.1 Corner joint welding

3.1.1 Corner joint welding, as adopted in some cases at the corners of tanks, performed with ordinary fillet welds, is permitted provided the welds are continuous and of the required size for the whole length on both sides of the joint.

3.1.2 Alternative solutions to corner joint welding may be considered by the Society on a case by case basis.

3.2 Bilge keel connection

3.2.1 The intermediate flat, through which the bilge keel is connected to the shell according to Ch 4, Sec 4, [6], is to be welded as a shell doubler by continuous fillet welds.

The butt welds of the doubler and bilge keel are to be full penetration and shifted from the shell butts.

The butt welds of the bilge plating and those of the doublers are to be flush in way of crossing, respectively, with the doubler and with the bilge keel.

3.3 Connection between propeller post and propeller shaft bossing

3.3.1 Fabricated propeller posts are to be welded with full penetration welding to the propeller shaft bossing.

3.4 Bar stem connections

3.4.1 The bar stem is to be welded to the bar keel generally with butt welding.

The shell plating is also to be welded directly to the bar stem with butt welding.

4 Workmanship

4.1 Welding procedures and consumables

4.1.1 The various welding procedures and consumables are to be used within the limits of their approval and in accordance with the conditions of use specified in the respective approval documents.

4.2 Welding operations

4.2.1 Weather protection

Adequate protection from the weather is to be provided to parts being welded; in any event, such parts are to be dry.

In welding procedures using bare, cored or coated wires with gas shielding, the welding is to be carried out in weather protected conditions, so as to ensure that the gas outflow from the nozzle is not disturbed by winds and draughts.

4.2.2 Butt connection edge preparation

The edge preparation is to be of the required geometry and correctly performed. In particular, if edge preparation is carried out by flame, it is to be free from cracks or other detrimental notches.

Recommendations for edge preparation are given in the "Guide for welding".

4.2.3 Surface condition

The surfaces to be welded are to be free from rust, moisture and other substances, such as mill scale, slag caused by oxygen cutting, grease or paint, which may produce defects in the welds.

Effective means of cleaning are to be adopted particularly in connections with special welding procedures; flame or mechanical cleaning may be required.

The presence of a shop primer may be accepted, provided it has been approved by the Society.

Shop primers are to be approved by the Society for a specific type and thickness according to Part D, Ch 5, Sec 3 of the Rules for the Classification of the Ships.

4.2.4 Assembling and gap

The setting appliances and system to be used for positioning are to ensure adequate tightening adjustment and an appropriate gap of the parts to be welded, while allowing maximum freedom for shrinkage to prevent cracks or other defects due to excessive restraint.

The gap between the edges is to comply with the required tolerances or, when not specified, it is to be in accordance with normal good practice.

4.2.5 Gap in fillet weld T connections (1/1/2017)

In fillet weld T connections, a gap g , as shown in Fig 11, not greater than 2 mm may be accepted without increasing

the throat thickness calculated according to [2.3.5] to [2.3.9], as applicable.

In the case of a gap greater than 2 mm, the above throat thickness is to be increased accordingly as specified in Sec 2 for some special connections of various ship types.

In any event, the gap g may not exceed 3 mm.

Figure 11 : Gap in fillet weld T connections

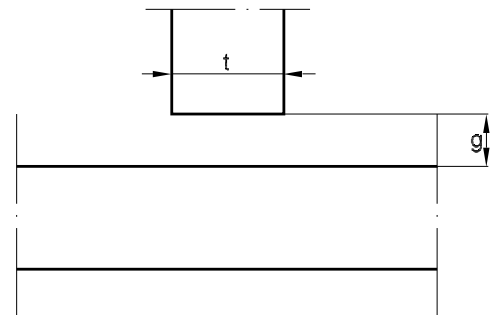

4.2.6 Plate misalignment in butt connections (1/1/2017)

The misalignment m , measured as shown in Fig 12, between plates with the same gross thickness t is to be less than $0,15t$, without being greater than 4 mm.

4.2.7 Misalignment in cruciform connections

The misalignment m in cruciform connections, measured on the median lines as shown in Fig 13, is to be less than:

- $t/2$, in general, where t is the gross thickness of the thinner abutting plate
- the values specified in Sec 2 for some special connections of various ship types.

The Society may require lower misalignment to be adopted for cruciform connections subjected to high stresses.

Figure 12 : Plate misalignment in butt connections

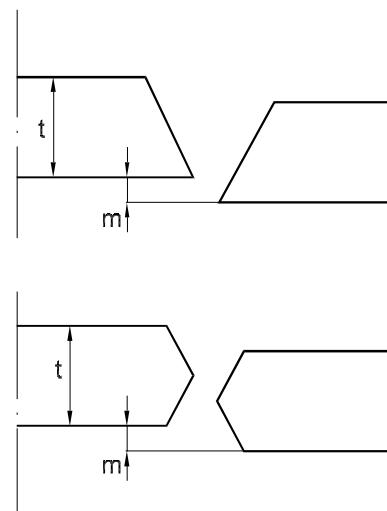
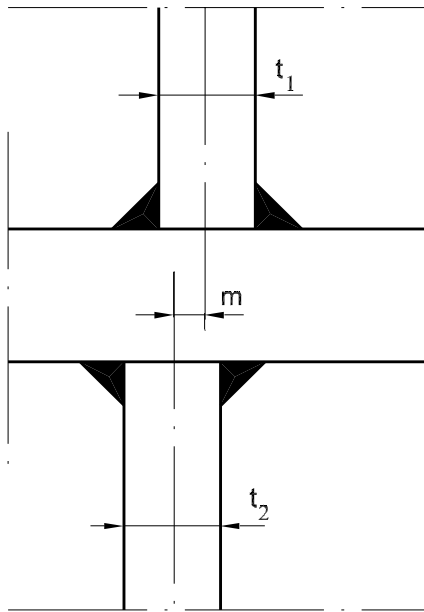

Figure 13 : Misalignment in cruciform connections**4.2.8 Assembling of aluminium alloy parts**

When welding aluminium alloy parts, particular care is to be taken so as to:

- reduce as far as possible restraint from welding shrinkage, by adopting assembling and tack welding procedures suitable for this purpose
- keep possible deformations within the allowable limits.

4.2.9 Preheating and interpass temperatures

Suitable preheating, to be maintained during welding, and slow cooling may be required by the Society on a case by case basis.

4.2.10 Welding sequences

Welding sequences and direction of welding are to be determined so as to minimise deformations and prevent defects in the welded connection.

All main connections are generally to be completed before the ship is afloat.

Departures from the above provision may be accepted by the Society on a case by case basis, taking into account any detailed information on the size and position of welds and the stresses of the zones concerned, both during ship launching and with the ship afloat.

4.2.11 Interpass cleaning

After each run, the slag is to be removed by means of a chipping hammer and a metal brush; the same precaution is to be taken when an interrupted weld is resumed or two welds are to be connected.

4.2.12 Stress relieving

It is recommended and in some cases it may be required that special structures subject to high stresses, having complex shapes and involving welding of elements of considerable thickness (such as rudder spades and stern frames), are

prefabricated in parts of adequate size and stress-relieved in the furnace, before final assembly, at a temperature within the range $550^{\circ}\text{C} \div 620^{\circ}\text{C}$, as appropriate for the type of steel.

4.3 Crossing of structural elements

4.3.1 In the case of T crossing of structural elements (one element continuous, the other physically interrupted at the crossing) when it is essential to achieve structural continuity through the continuous element (continuity obtained by means of the welded connections at the crossing), particular care is to be devoted to obtaining the correspondence of the interrupted elements on both sides of the continuous element. Suitable systems for checking such correspondence are to be adopted.

5 Modifications and repairs during construction**5.1 General**

5.1.1 Deviations in the joint preparation and other specified requirements, in excess of the permitted tolerances and found during construction, are to be repaired as agreed with the Society on a case by case basis.

5.2 Gap and weld deformations

5.2.1 Welding by building up of gaps exceeding the required values and repairs of weld deformations may be accepted by the Society upon special examination.

5.3 Defects

5.3.1 Defects and imperfections on the materials and welded connections found during construction are to be evaluated for possible acceptance on the basis of the applicable requirements of the Society.

Where the limits of acceptance are exceeded, the defective material and welds are to be discarded or repaired, as deemed appropriate by the Surveyor on a case by case basis.

When any serious or systematic defect is detected either in the welded connections or in the base material, the manufacturer is required to promptly inform the Surveyor and submit the repair proposal.

The Surveyor may require destructive or non-destructive examinations to be carried out for initial identification of the defects found and, in the event that repairs are undertaken, for verification of their satisfactory completion.

5.4 Repairs on structures already welded

5.4.1 In the case of repairs involving the replacement of material already welded on the hull, the procedures to be adopted are to be agreed with the Society on a case by case basis.

6 Inspections and checks

6.1 General

6.1.1 Materials, workmanship, structures and welded connections are to be subjected, at the beginning of the work, during construction and after completion, to inspections by the Shipyard suitable to check compliance with the applicable requirements, approved plans and standards.

6.1.2 The manufacturer is to make available to the Surveyor a list of the manual welders and welding operators and their respective qualifications.

The manufacturer's internal organisation is responsible for ensuring that welders and operators are not employed under improper conditions or beyond the limits of their respective qualifications and that welding procedures are adopted within the approved limits and under the appropriate operating conditions.

6.1.3 The manufacturer is responsible for ensuring that the operating conditions, welding procedures and work schedule are in accordance with the applicable requirements, approved plans and recognised good welding practice.

6.2 Visual and non-destructive examinations

6.2.1 After completion of the welding operation and workshop inspection, the structure is to be presented to the Sur-

veyor for visual examination at a suitable stage of fabrication.

As far as possible, the results on non-destructive examinations are to be submitted.

6.2.2 Non-destructive examinations are to be carried out with appropriate methods and techniques suitable for the individual applications, to be agreed with the Surveyor on a case by case basis.

6.2.3 Radiographic examinations are to be carried out on the welded connections of the hull in accordance with the Society's requirements. The Surveyor is to be informed when these examinations are performed. The results are to be made available to the Society.

6.2.4 The Society may allow radiographic examinations to be partially replaced by ultrasonic examinations.

6.2.5 When the visual or non-destructive examinations reveal the presence of unacceptable indications, the relevant connection is to be repaired to sound metal for an extent and according to a procedure agreed with the Surveyor. The repaired zone is then to be submitted to non-destructive examination, using a method deemed suitable by the Surveyor to verify that the repair is satisfactory.

Additional examinations may be required by the Surveyor on a case by case basis.

6.2.6 Ultrasonic and magnetic particle examinations may also be required by the Surveyor in specific cases to verify the quality of the base material.

SECTION 2

SPECIAL STRUCTURAL DETAILS

Symbols

T_B : Ship's draft in light ballast condition, see Ch 5, Sec 1, [2.4.3].

1 General

1.1 Application

1.1.1 (1/1/2017)

Special structural details are those characterised by complex geometry, possibly associated with high or alternate stresses.

In addition, the hull areas in which they are located are such that the ship operation and overall safety could be impaired by an unsatisfactory structural performance of the detail.

1.1.2 (1/1/2017)

For special structural details, specific requirements are to be fulfilled during:

- design
- construction
- selection of materials
- welding
- survey.

The purpose of these requirements is specified in [1.2] to [1.6].

1.1.3 (1/1/2017)

Special structural details are those listed in [2] together with the specific requirements which are to be fulfilled.

Other structural details may be considered by the Society as special details, when deemed necessary on the basis of the criteria in [1.1.1]. The criteria to be fulfilled in such cases are defined by the Society on a case by case basis.

1.1.4 (1/1/2017)

As regards matters not explicitly specified in [2], the Rule requirements are to be complied with in any event; in particular:

- Chapter 4 for design principles and structural arrangements
- Chapter 7 for structural scantling
- Chapter 11 for construction and welding requirements
- the applicable requirements in Part D and Part E.

1.2 Design requirements

1.2.1 General requirements (1/1/2017)

Design requirements specify:

- the local geometry, dimensions and scantlings of the structural elements which constitute the detail
- any local strengthening
- the cases where a fatigue check is to be carried out according to Ch 7, Sec 4.

1.2.2 Fatigue check requirements (1/1/2017)

Where a fatigue check is to be carried out, the design requirements specify see Ch 7, Sec 4, [3]:

- the locations (hot spots) where the stresses are to be calculated and the fatigue check performed
- the direction in which the normal stresses are to be calculated
- the stress concentration factors K_h and K_ℓ to be used for calculating the hot spot stress range.

1.3 Constructional requirements

1.3.1 (1/1/2017)

Constructional requirements specify the allowable misalignment and tolerances, depending on the detail arrangement and any local strengthening.

1.4 Material requirements

1.4.1 (1/1/2017)

Material requirements specify the material quality to be used for specific elements which constitute the detail, depending on their manufacturing procedure, the type of stresses they are subjected to, and the importance of the detail with respect to the ship operation and overall safety.

In addition, these requirements specify where material inspections are to be carried out.

1.5 Welding requirements

1.5.1 (1/1/2017)

Welding requirements specify where partial or full T penetration welding (see Sec 1, [2.4]) or any particular welding type or sequence is to be adopted. In addition, these requirements specify when welding procedures are to be approved.

For some fillet welding connections the minimum required throat thickness is also specified.

Since weld shape and undercuts are influencing factors on fatigue behaviour, fillet welds are to be elongated in the direction of the highest stresses and care is to be taken to avoid undercuts, in particular at the hot spots.

1.6 Survey requirements

1.6.1 (1/1/2017)

Survey requirements specify where non-destructive examinations of welds are to be carried out and, where this is the case, which type is to be adopted.

2 List and characteristics of special structural details

2.1 General

2.1.1 (1/1/2017)

This Article lists and describes, depending on the ship type, the special structural details and specifies the specific requirements which are to be fulfilled according to [1.2] to [1.6]. This is obtained through:

- a description of the hull areas where the details are located
- the detail description
- the requirements for the fatigue check

- a reference to a sheet in the Appendixes where a picture of the detail is shown together with the specific requirements which are to be fulfilled.

2.2 All types of ships with longitudinally framed sides

2.2.1 (1/1/2017)

The special structural details relevant to all types of longitudinally framed ships are listed and described in Tab 1.

2.3 Auxiliary (cargo tank regions)

2.3.1 (1/1/2017)

The special structural details relevant to ships with the service notation auxiliary are listed and described in Tab 2 for various hull areas.

When the structural arrangement in a certain area is such that the details considered in Tab 2 are not possible, specific requirements are defined by the Society on a case by case basis, depending on the arrangement adopted.

Table 1 : Ships with longitudinally framed sides - Special structural details (1/1/2017)

Area reference number	Area description	Detail description	Fatigue check	Reference sheet in App 1
1	Part of side extended: <ul style="list-style-type: none"> longitudinally, between the after peak bulkhead and the collision bulkhead vertically, between $0,7T_B$ and $1,15T$ from the baseline 	Connection of side longitudinal ordinary stiffeners with transverse primary supporting members	No	Sheets 1.1 to 1.6
		Connection of side longitudinal ordinary stiffeners with stiffeners of transverse primary supporting members	For $L \geq 90m$	Sheets 1.7 to 1.13

Table 2 : Auxiliary (cargo tank regions) - Special structural details (1/1/2017)

Area reference number	Area description	Detail description	Fatigue check	Reference sheet in App 1
1	Part of side extended: <ul style="list-style-type: none"> longitudinally, between the after peak bulkhead and the collision bulkhead vertically, between $0,7T_B$ and $1,15T$ from the baseline 	Connection of side longitudinal ordinary stiffeners with transverse primary supporting members	No	Sheets 1.1 to 1.6
		Connection of side longitudinal ordinary stiffeners with stiffeners of transverse primary supporting members	For $L \geq 90m$	Sheets 1.7 to 1.13
2	Part of inner side and longitudinal bulkheads in the cargo area extended vertically above half tank height, where the tank breadth exceeds $0,55B$	Connection of inner side or bulkhead longitudinal ordinary stiffeners with transverse primary supporting members	No	Sheets 2.1 to 2.6
		Connection of inner side or bulkhead longitudinal ordinary stiffeners with stiffeners of transverse primary supporting members	For $L \geq 90m$	Sheets 2.7 to 2.13
3	Double bottom in way of transverse bulkheads	Connection of bottom and inner bottom longitudinal ordinary stiffeners with floors	For $L \geq 90m$	Sheets 3.1 to 3.3
		Connection of inner bottom with transverse bulkheads or lower stools	For $L \geq 90m$	Sheet 3.4
4	Double bottom in way of hopper tanks	Connection of inner bottom with hopper tank sloping plates	For $L \geq 90m$	Sheets 4.1 to 4.4
5	Lower part of transverse bulkheads with lower stools	Connection of lower stools with plane bulkheads	For $L \geq 90m$	Sheets 5.1 to 5.7
6	Lower part of inner side	Connection of hopper tank sloping plates with inner side	For $L \geq 90m$	Sheets 6.1 to 6.7
7	Hatch corners	Deck plating in way of hatch corners	No	Sheet 7.1
		Ends of longitudinal hatch coamings	No	Sheets 7.2, 7.3

SECTION 3

TESTING

1 General

1.1 Purpose and application

1.1.1 Purpose (1/1/2017)

The test procedures in this Section are to confirm the watertightness of tanks and watertight boundaries and the structural adequacy of tanks which form the watertight subdivisions of ships. These procedures may also be applied to verify the weathertightness of structures and shipboard outfitting. The tightness of all tanks and watertight boundaries of ships during new construction and those relevant to major conversions or major repairs (see Note 1) is to be confirmed by these test procedures prior to the delivery of the ship.

Note 1: Major repair means a repair affecting structural integrity.

1.1.2 Application (1/1/2017)

All gravity tanks (see Note 1) and other boundaries required to be watertight or weathertight are to be tested in accordance with the requirements of this Section and proven to be tight and structurally adequate as follows:

- Gravity Tanks for their tightness and structural adequacy,
- Watertight Boundaries Other Than Tank Boundaries for their watertightness, and
- Weathertight Boundaries for their weathertightness.

The testing of structures not listed in Tab 1 or Tab 2 is to be specially considered.

Note 1: Gravity tank means a tank that is subject to vapour pressure not greater than 70 kPa.

1.2 Definitions

1.2.1 Shop primer (1/1/2017)

Shop primer is a thin coating applied after surface preparation and prior to fabrication as a protection against corrosion during fabrication.

1.2.2 Protective coating (1/1/2017)

Protective coating is a final coating protecting the structure from corrosion.

1.2.3 Structural test (1/1/2017)

A structural test is a test to verify the structural adequacy of tank construction. This may be a hydrostatic test or, where the situation warrants, a hydropneumatic test.

1.2.4 Leak test (1/1/2017)

A leak test is a test to verify the tightness of a boundary. Unless a specific test is indicated, this may be a hydrostatic/hydropneumatic test or an air test. A hose test may be

considered an acceptable form of leak test for certain boundaries, as indicated in Tab 1, Note 3.

1.2.5 Hydrostatic test (leak and structural) (1/1/2017)

A hydrostatic test is a test wherein a space is filled with a liquid to a specified head.

1.2.6 Hydropneumatic test (leak and structural) (1/1/2017)

A hydropneumatic test is a test combining a hydrostatic test and an air test, wherein a space is partially filled with liquid and pressurized with air.

1.2.7 Hose test (leak) (1/1/2017)

A hose test is a test to verify the tightness of a joint by a jet of water with the joint visible from the opposite side.

1.2.8 Air test (leak) (1/1/2017)

An air test is a test to verify the tightness by means of air pressure differential and leak indicating solution. It includes tank air test and joint air tests, such as compressed air fillet weld tests and vacuum box tests.

1.2.9 Compressed air fillet weld test (leak) (1/1/2017)

A compressed air fillet weld test is an air test of fillet welded tee joints wherein leak indicating solution is applied on fillet welds.

1.2.10 Vacuum box test (leak) (1/1/2017)

A vacuum box test is a box over a joint with leak indicating solution applied on the welds. A vacuum is created inside the box to detect any leaks.

1.2.11 Ultrasonic test (leak) (1/1/2017)

An ultrasonic test is a test to verify the tightness of the sealing of closing devices such as hatch covers by means of ultrasonic detection techniques.

1.2.12 Penetration test (leak) (1/1/2017)

A penetration test is a test to verify that no visual dye penetrant indications of potential continuous leakages exist in the boundaries of a compartment by means of low surface tension liquids (i.e. dye penetrant test).

1.2.13 Margin line (1/1/2017)

The margin line is a line drawn at least 76 mm below the upper surface of the bulkhead deck at side.

1.2.14 Sister ship (1/1/2017)

A sister ship is a ship having the same main dimensions, general arrangement, capacity plan and structural design as those of the first ship in a series.

2 Test procedures

2.1 General

2.1.1 (1/1/2017)

Tests are to be carried out in the presence of a Surveyor at a stage sufficiently close to the completion of work with all hatches, doors, windows, etc., installed and all penetrations including pipe connections fitted, and before any ceiling and cement work is applied over the joints.

In particular, tests are to be carried out after air vents and sounding pipes have been fitted.

Specific test requirements are given in [2.4] and Tab 1. For the timing of the application of coating and the provision of safe access to joints, see [2.5], [2.6] and Tab 3.

2.2 Structural test procedures

2.2.1 Type and time of test (1/1/2017)

Where a structural test is specified in Tab 1 or Tab 2, a hydrostatic test in accordance with [2.4.1] will be acceptable. Where practical limitations (strength of building berth, light density of liquid, etc.) prevent the performance of a hydrostatic test, a hydropneumatic test in accordance with [2.4.2] may be accepted instead.

A hydrostatic test or hydropneumatic test for the confirmation of structural adequacy may be carried out while the vessel is afloat, provided the results of a leak test are confirmed to be satisfactory before the vessel is afloat.

2.2.2 Testing schedule for new construction or major structural conversion (1/1/2017)

- a) The tank boundaries are to be tested from at least one side. The tanks for structural testing are to be selected so that all representative structural members are tested for the expected tension and compression.
- b) Structural tests are to be carried out on at least one tank of a group of tanks having structural similarity (i.e. same design conditions, alike structural configurations with only minor localised differences determined to be acceptable by the attending Surveyor) on each vessel provided all other tanks are tested for leaks by an air test. The acceptance of leak testing using an air test instead of a structural test does not apply to cargo space boundaries adjacent to other compartments in tankers and combination carriers or to the boundaries of tanks for segregated cargoes or pollutant cargoes in other types of ships.
- c) Additional tanks may require structural testing if found necessary after the structural testing of the first tank.
- d) Where the structural adequacy of the tanks of a vessel was verified by the structural testing required in Tab 1, subsequent vessels in the series (i.e. sister ships built

from the same plans at the same shipyard) may be exempted from structural testing of tanks, provided that:

- 1) Watertightness of boundaries of all tanks is verified by leak tests and thorough inspections are carried out.
 - 2) Structural testing is carried out on at least one tank of each type among all tanks of each sister vessel.
 - 3) Additional tanks may require structural testing if found necessary after the structural testing of the first tank or if deemed necessary by the attending Surveyor.
- For cargo space boundaries adjacent to other compartments in tankers and combination carriers or boundaries of tanks for segregated cargoes or pollutant cargoes in other types of ships, the provisions of b) are to be applied in lieu of d) 2
- e) Sister ships built (i.e. keel laid) two years or more after the delivery of the last ship of the series, may be tested in accordance with d) at the discretion of the Society, provided that:
 - 1) general workmanship has been maintained (i.e. there has been no discontinuity of shipbuilding or significant changes in the construction methodology or technology at the yard, shipyard personnel are appropriately qualified and demonstrate an adequate level of workmanship as determined by the Society) and,
 - 2) an enhanced NDT programme is implemented for the tanks not subject to structural tests.
 - f) For the watertight boundaries of spaces other than tanks, structural testing may be exempted, provided that the watertightness of boundaries of exempted spaces is verified by leak tests and inspections. Structural testing is not exempt and the requirements for structural testing of tanks in a) to e) are to be applied, for ballast holds, chain lockers and a representative cargo hold if intended for in-port ballasting.

2.3 Leak test procedures

2.3.1 (1/1/2017)

For the leak test specified in Tab 1, tank air tests, compressed air fillet weld test, vacuum box test in accordance with [2.4.4] to [2.4.6], or their combination will be acceptable. Hydrostatic or hydropneumatic tests may also be accepted as leak tests provided that [2.5], [2.6] and [2.7] are complied with. Hose tests will also be acceptable for such locations as specified in Tab 1, Note 3, in accordance with [2.4.3].

Air tests of joints may be carried out in the block stage provided that all work on the block that may affect the tightness of a joint is completed before the test. See also [2.5.1] for the application of final coatings and [2.6] for the safe access to joints and the summary in Tab 3.

2.4 Test methods

2.4.1 Hydrostatic test (1/1/2017)

Unless another liquid is approved, hydrostatic tests are to consist of filling the space with fresh water or sea water,

whichever is appropriate for testing, to the level specified in Tab 1 or Tab 2.

In cases where a tank for higher density cargoes is to be tested with fresh water or sea water, the testing pressure height is to be specially considered.

All external surfaces of the tested space are to be examined for structural distortion, bulging and buckling, other related damage and leaks.

2.4.2 Hydropneumatic test (1/1/2017)

Hydropneumatic tests, where approved, are to be such that the test condition in conjunction with the approved liquid level and supplemental air pressure will simulate the actual loading as far as practicable. The requirements and recommendations for tank air tests in [2.4.4] will also apply to hydropneumatic tests.

All external surfaces of the tested space are to be examined for structural distortion, bulging and buckling, other related damage and leaks.

2.4.3 Hose test (1/1/2017)

Hose tests are to be carried out with the pressure in the hose nozzle maintained at least at $2 \cdot 10^5$ Pa during the test. The nozzle is to have a minimum inside diameter of 12 mm and be at a perpendicular distance from the joint not exceeding 1,5 m.

The water jet is to impinge directly upon the weld.

Where a hose test is not practical because of possible damage to machinery, electrical equipment insulation or outfitting items, it may be replaced by a careful visual examination of welded connections, supported where necessary by means such as a dye penetrant test or ultrasonic leak test or the equivalent.

2.4.4 Tank air test (1/1/2017)

All boundary welds, erection joints and penetrations, including pipe connections, are to be examined in accordance with approved procedure and under a stabilized pressure differential above atmospheric pressure not less than $0,15 \cdot 10^5$ Pa, with a leak indicating solution such as soapy water/detergent or a proprietary brand applied.

A U-tube with a sufficient height to hold a head of water corresponding to the required test pressure is to be arranged. Instead of using a U-tube, two calibrated pressure gauges may be acceptable to verify the required test pressure.

A double inspection is to be made of tested welds. The first is to be immediately upon applying the leak indicating solution; the second is to be after approximately four or five minutes in order to detect those smaller leaks which may take time to appear.

2.4.5 Compressed air fillet weld test (1/1/2017)

In this air test, compressed air is injected from one end of a fillet welded joint and the pressure verified at the other end of the joint by a pressure gauge. Pressure gauges are to be arranged so that an air pressure of at least $0,15 \cdot 10^5$ Pa can

be verified at each end of all passages within the portion being tested.

Note 1: Where a leak test is required for fabrication involving partial penetration welds, a compressed air test is also to be applied in the same manner as for a fillet weld where the root face is large, i.e., 6-8 mm.

2.4.6 Vacuum box test (1/1/2017)

A box (vacuum testing box) with air connections, gauges and an inspection window is placed over the joint with a leak indicating solution applied to the weld cap vicinity. The air within the box is removed by an ejector to create a vacuum of $0,20 \cdot 10^5$ - $0,26 \cdot 10^5$ Pa inside the box.

2.4.7 Ultrasonic test (1/1/2017)

An ultrasonic echo transmitter is to be arranged inside a compartment and a receiver is to be arranged on the outside. The watertight/weathertight boundaries of the compartment are scanned with the receiver in order to detect an ultrasonic leak indication. A location where sound is detectable by the receiver indicates a leakage in the sealing of the compartment.

2.4.8 Penetration test (1/1/2017)

A test of butt welds or other weld joints uses the application of a low surface tension liquid at one side of a compartment boundary or structural arrangement. If no liquid is detected on the opposite sides of the boundaries after the expiration of a defined period of time, this indicates tightness of the boundaries. In certain cases, a developer solution may be painted or sprayed on the other side of the weld to aid leak detection.

2.4.9 Other tests (1/1/2017)

Other methods of testing may be considered by the Society upon submission of full particulars prior to commencement of testing.

2.5 Application of coating

2.5.1 Final coating (1/1/2017)

For butt joints welded by an automatic process, the final coating may be applied any time before the completion of a leak test of spaces bounded by the joints, provided that the welds have been carefully inspected visually to the satisfaction of the Surveyor.

Surveyors reserve the right to require a leak test prior to the application of final coating over automatic erection butt welds.

For all other joints, the final coating is to be applied after completion of the leak test of the joint. See also Tab 3.

2.5.2 Temporary coating (1/1/2017)

Any temporary coating which may conceal defects or leaks is to be applied at the time as specified for the final coating (see [2.5.1]). This requirement does not apply to shop primer.

2.6 Safe access to joints

2.6.1 (1/1/2017)

For leak tests, safe access to all joints under examination is to be provided. See also Tab 3.

2.7 Hydrostatic or hydropneumatic tightness test

2.7.1 (1/1/2017)

In cases where the hydrostatic or hydropneumatic tests are applied instead of a specific leak test, examined boundaries must be dew-free, otherwise small leaks are not visible.

2.8 Other testing methods

2.8.1 Other testing methods may be accepted, at the discretion of the Society, based upon equivalency considerations.

2.9 Acceptance criteria for watertight doors

2.9.1 (1/1/2017)

The following acceptable leakage criteria apply:

Doors with gaskets:	No leakage
Doors with metallic sealing:	Maximum leakage 1 l/min

For doors of passenger ships which are normally open and used at sea and which become submerged by the equilibrium or intermediate waterplane, a prototype test is to be conducted, on each side of the door, to check the satisfactory closing of the door against a force equivalent to a water height of at least 1 m above the sill on the centreline of the door.

3 Miscellaneous

3.1 Watertight decks, trunks, etc.

3.1.1 *After completion, a hose or flooding test is to be applied to watertight decks and a hose test to watertight trunks, tunnels and ventilators.*

3.2 Doors in bulkheads above the bulkhead deck

3.2.1 Doors are to be designed and constructed as weathertight doors and, after installation, subjected to a hose test from each side for weathertightness.

3.3 Semi-watertight doors

3.3.1 Semi-watertight doors are those defined in Pt F, Ch 13, Sec 11, [2.1.4].

These means of closure are to be subjected to a structural test at the manufacturer's works. The head of water is to be up to the highest waterline after damage at the equilibrium of the intermediate stages of flooding. The duration of the test is to be at least 30 min.

A leakage quantity of approximately 100 l/hour is considered as being acceptable for a 1,35 m² opening.

The means of closure are to be subjected to a hose test after fitting on board.

3.4 Steering nozzles

3.4.1 Upon completion of manufacture, the nozzle is to be subjected to a leak test.

4 Working tests

4.1 Working test of windlass

4.1.1 The working test of the windlass is to be carried out on board in the presence of a Surveyor.

4.1.2 The test is to demonstrate that the windlass complies with the requirements of Ch 9 Sec 4, [3.7] and, in particular, that it works adequately and has sufficient power to simultaneously weigh the two bower anchors (excluding the housing of the anchors in the hawse pipe) when both are suspended to 55 m of chain cable, in not more than 6 min.

4.1.3 Where two windlasses operating separately on each chain cable are adopted, the weighing test is to be carried out for both, weighing an anchor suspended to 82,5 m of chain cable and verifying that the time required for the weighing (excluding the housing in the hawse pipe) does not exceed 9 min.

Table 1 : Test Requirements for tanks and boundaries (1/1/2017)

Item	Tank or boundary to be tested	Test type	Test head or pressure	Remarks
1	Double bottom tanks (4)	Leak and structural (1)	The greater of: - top of the overflow, - to 2,4m above top of tank (2), or - to bulkhead deck	
2	Double bottom voids (5)	Leak	See [2.4.4] through [2.4.6], as applicable	Including pump room double bottom and bunker tank protection double hull required by MARPOL Annex I
3	Double side tanks	Leak and structural (1)	The greater of - top of the overflow, - to 2,4m above top of tank (2), or - to bulkhead deck	
4	Double side voids	Leak	See [2.4.4] through [2.4.6], as applicable	
5	Deep tanks other than those listed elsewhere in this table	Leak and structural (1)	The greater of - top of the overflow, or - to 2.4m above top of tank (2)	
6	Cargo oil tanks of supply ships	Leak and structural (1)	The greater of - top of the overflow, - to 2,4m above top of tank (2), or - to top of tank (2) plus setting of any pressure relief valve	
7	Ballast hold of bulk carriers	Leak and structural (1)	Top of cargo hatch coaming	
8	Peak tanks	Leak and structural (1)	The greater of - top of the overflow, or - to 2,4m above top of tank (2)	After peak to be tested after installation of stern tube
9	a) Fore peak spaces with equipment	Leak	See [2.4.3] through [2.4.6], as applicable	
	b) Fore peak voids	Leak and structural (1) (9)	To bulkhead deck	
	c) Aft peak spaces with equipment	Leak	See [2.4.3] through [2.4.6], as applicable	
	d) Aft peak voids	Leak	See [2.4.4] through [2.4.6], as applicable	After peak to be tested after installation of stern tube

(1) Refer to [2.2.2].

(2) The top of a tank is the deck forming the top of the tank, excluding any hatchways.

(3) Hose Test may also be considered as a test medium. See [1.2].

(4) Including tanks arranged in accordance with the provisions of SOLAS regulation II-1/9.4.

(5) Including duct keels and dry compartments arranged in accordance with the provisions of SOLAS regulation II-1/11.2 and II-1/9.4 respectively, and/or oil fuel tank protection and pump room bottom protection arranged in accordance with the provisions of MARPOL Annex I, Chapter 3, Part A regulation 12A and Chapter 4, Part A, regulation 22 respectively.

(6) Where watertightness of a watertight doors has not been confirmed by prototype test, testing by filling watertight spaces with water is to be carried out. See SOLAS regulation II-1/16.2 and MSC/Circ.1176.

(7) As an alternative to the hose test, other testing methods listed in [2.4.7] through [2.4.9] may be applicable subject to the adequacy of such testing methods being verified. See SOLAS regulation II-1/11.1. For watertight bulkheads (item 11.a), alternatives to hose testing may only be used where a hose test is not practicable.

(8) A "Leak and structural test", see [2.2.2] is to be carried out for a representative cargo hold if intended for in-port ballasting. The filling level requirement for testing cargo holds intended for in-port ballasting is to be the maximum loading that will occur in-port as indicated in the loading manual.

(9) Structural test may be waived where demonstrated to be impracticable to the satisfaction of the Society.

Item	Tank or boundary to be tested	Test type	Test head or pressure	Remarks
10	Cofferdams	Leak	See [2.4.4] through [2.4.6], as applicable	
11	a) Watertight bulkheads	Leak	See [2.4.3] through [2.4.6], as applicable (7)	
	b) Superstructure end bulkheads	Leak	See [2.4.3] through [2.4.6], as applicable	
12	Watertight doors below free-board or bulkhead deck	Leak (6) (7)	See [2.4.3] through [2.4.6], as applicable	
13	Double plate rudder blades	Leak	See [2.4.3] through [2.4.6], as applicable	
14	Shaft tunnels clear of deep tanks	Leak (3)	See [2.4.3] through [2.4.6], as applicable	
15	Shell doors	Leak (3)	See [2.4.3] through [2.4.6], as applicable	
16	Weather-tight hatch covers and closing appliances	Leak (3) (7)	See [2.4.3] through [2.4.6], as applicable	Hatch covers closed by tarpaulins and battens excluded
17	Dual purpose tanks/dry cargo hatch covers	Leak (3) (7)	See [2.4.3] through [2.4.6], as applicable	In addition to structural test in item 6 or 7 of this table
18	Chain lockers	Leak and structural (1)	Top of chain pipe	
19	L.O. sump. tanks and other similar tanks/spaces under main engines	Leak	See [2.4.3] through [2.4.6], as applicable	
20	Ballast ducts	Leak and structural (1)	The greater of - ballast pump maximum pressure, or - setting of any pressure relief valve	
21	Fuel Oil Tanks	Leak and structural (1)	The greater of- top of the overflow, - to 2.4m above top of tank (2), or - to top of tank (2) plus setting of any pressure relief valve, or - to bulkhead deck	

- (1) Refer to [2.2.2].
- (2) The top of a tank is the deck forming the top of the tank, excluding any hatchways.
- (3) Hose Test may also be considered as a test medium. See [1.2].
- (4) Including tanks arranged in accordance with the provisions of SOLAS regulation II-1/9.4.
- (5) Including duct keels and dry compartments arranged in accordance with the provisions of SOLAS regulation II-1/11.2 and II-1/9.4 respectively, and/or oil fuel tank protection and pump room bottom protection arranged in accordance with the provisions of MARPOL Annex I, Chapter 3, Part A regulation 12A and Chapter 4, Part A, regulation 22 respectively.
- (6) Where watertightness of a watertight doors has not been confirmed by prototype test, testing by filling watertight spaces with water is to be carried out. See SOLAS regulation II-1/16.2 and MSC/Circ.1176.
- (7) As an alternative to the hose test, other testing methods listed in [2.4.7] through [2.4.9] may be applicable subject to the adequacy of such testing methods being verified. See SOLAS regulation II-1/11.1. For watertight bulkheads (item 11.a), alternatives to hose testing may only be used where a hose test is not practicable.
- (8) A "Leak and structural test", see [2.2.2] is to be carried out for a representative cargo hold if intended for in-port ballasting. The filling level requirement for testing cargo holds intended for in-port ballasting is to be the maximum loading that will occur in-port as indicated in the loading manual.
- (9) Structural test may be waived where demonstrated to be impracticable to the satisfaction of the Society.

Table 2 : Additional test requirements for special service ships/tanks (1/1/2017)

	Type of ship/tank	Structures to be tested	Type of test	Test head or pressure	Remarks
1	Liquefied gas carrier	Integral tanks	Leak and structural	The greater of - to 2,4m above top of tank (1) , or - to top of tank (1) plus setting of any pressure relief valve See also Pt E, Ch 9, Sec 4, [13.1]	Where a cargo tank is designed for the carriage of cargoes with specific gravities greater than 1,0, an appropriate additional head is to be considered
		Hull structure supporting membrane or semi-membrane tanks		The greater of - to 2,4m above top of tank (1) , or - to top of tank (1) plus setting of any pressure relief valve See also Pt E, Ch 9, Sec 4, [13.2]	Where a cargo tank is designed for the carriage of cargoes with specific gravities greater than 1,0, an appropriate additional head is to be considered
		Independent tanks type A		See Pt E, Ch 9, Sec 4, [13.3]	
		Independent tanks type B		See Pt E, Ch 9, Sec 4, [13.3]	
		Independent tanks type C		See Pt E, Ch 9, Sec 4, [13.3]	
2	Edible liquid tanks	Independent tanks	Leak and structural	The greater of - top of the overflow, or - to 0,9m above top of tank (1)	
3	Chemical carriers	Integral or independent cargo tanks	Leak and structural	The greater of - to 2,4m above top of tank (1) , or - to top of tank (1) plus setting of any pressure relief valve	Where a cargo tank is designed for the carriage of cargoes with specific gravities greater than 1,0, an appropriate additional head is to be considered
(1) Top of tank is deck forming the top of the tank excluding any hatchways.					

Table 3 : Application of leak test, coating and provision of safe access for type of welded joints (1/1/2017)

Type of welded joints		Leak test	Coating (1)		Safe access (2)	
			Before leak test	After leak test but before structural test	Leak test	Structural test
Butt	Automatic	Not required	Allowed (3)	N/A	Not required	Not required
	Manual or Semi-automatic (4)	Required	Not allowed	Allowed	Required	Not required
Fillet	Boundary including penetrations	Required	Not allowed	Allowed	Required	Not required

(1) Coating refers to internal (tank/hold coating), where applied, and external (shell/deck) painting. It does not refer to shop primer.

(2) Temporary means of access for verification of the leak test.

(3) The condition applies provided that the welds have been carefully inspected visually to the satisfaction of the Surveyor.

(4) Flux Core Arc Welding (FCAW) semiautomatic butt welds need not be tested provided that careful visual inspections show continuous uniform weld profile shape, free from repairs, and the results of NDE testing show no significant defects.

APPENDIX 1

WELDING DETAILS

1 Contents

1.1 General

1.1.1 Types and edge plate preparation of the manual welds carried out on the various parts of the hull are dealt with in this Appendix.

Other types and tolerances may be used after special examination of the Society.

1.1.2 The method used to prepare the parts to be welded is left to the discretion of each shipyard, according to its own technology and experience. It is approved at the same time as the approval of the welding procedures referred to in Sec 1, [1.3.1].

1.2 Butt welding edge preparation

1.2.1 Typical butt weld plate edge preparation for manual welding is specified in Tab 1 and Tab 2.

1.3 Lap-joint, slot and plug welding

1.3.1 Welding details of lap-joint, slot and plug welds are specified in Tab 3.

Table 1 : Typical butt weld plate edge preparation (manual welding) - See Note 1

Detail	Standard
<p>Square butt</p> 	$t \leq 5 \text{ mm}$ $G = 3 \text{ mm}$
<p>Single bevel butt</p> 	$t > 5 \text{ mm}$ $G \leq 3 \text{ mm}$ $R \leq 3 \text{ mm}$ $50^\circ \leq \theta \leq 70^\circ$
<p>Double bevel butt</p> 	$t > 19 \text{ mm}$ $G \leq 3 \text{ mm}$ $R \leq 3 \text{ mm}$ $50^\circ \leq \theta \leq 70^\circ$
<p>Double vee butt, uniform bevels</p> 	$G \leq 3 \text{ mm}$ $R \leq 3 \text{ mm}$ $50^\circ \leq \theta \leq 70^\circ$
<p>Double vee butt, non-uniform bevels</p> 	$G \leq 3 \text{ mm}$ $R \leq 3 \text{ mm}$ $6 \leq h \leq t/3 \text{ mm}$ $\theta = 50^\circ$ $\alpha = 90^\circ$
<p>Note 1: Different plate edge preparation may be accepted or approved by the Society on the basis of an appropriate welding procedure specification.</p>	

Table 2 : Typical butt weld plate edge preparation (manual welding) - See Note 1

Detail	Standard
<p>Single vee butt, one side welding with backing strip (temporary or permanent)</p> 	$3 \leq G \leq 9 \text{ mm}$ $30^\circ \leq \theta \leq 45^\circ$
<p>Single vee butt</p> 	$G \leq 3 \text{ mm}$ $50^\circ \leq \theta \leq 70^\circ$ $R \leq 3 \text{ mm}$
<p>Note 1: Different plate edge preparation may be accepted or approved by the Society on the basis of an appropriate welding procedure specification.</p>	

Table 3 : Typical lap joint, plug and slot welding (manual welding)

Detail	Standard	Remark
<p>Fillet weld in lap joint</p> 	$b = 2 t_2 + 25 \text{ mm}$	location of lap joint to be approved by the Society
<p>Fillet weld in joggled lap joint</p> 	$b \geq 2 t_2 + 25 \text{ mm}$	
<p>Plug welding</p> 	<ul style="list-style-type: none"> • $t \leq 12 \text{ mm}$ $l = 60 \text{ mm}$ $R = 6 \text{ mm}$ $40^\circ \leq \theta \leq 50^\circ$ $G = 12 \text{ mm}$ $L > 2 l$ • $12 \text{ mm} < t \leq 25 \text{ mm}$ $l = 80 \text{ mm}$ $R = 0,5 t \text{ mm}$ $\theta = 30^\circ$ $G = t \text{ mm}$ $L > 2 l$ 	
<p>Slot welding</p> 	<ul style="list-style-type: none"> • $t \leq 12 \text{ mm}$ $G = 20 \text{ mm}$ $l = 80 \text{ mm}$ $2 l \leq L \leq 3 l, \text{ max } 250 \text{ mm}$ • $t > 12 \text{ mm}$ $G = 2 t$ $l = 100 \text{ mm}$ $2 l \leq L \leq 3 l, \text{ max } 250 \text{ mm}$ 	

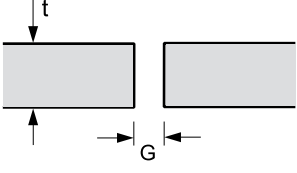
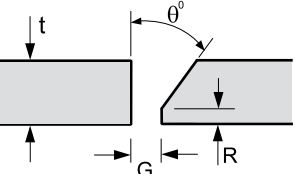
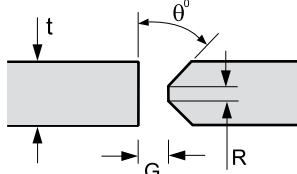
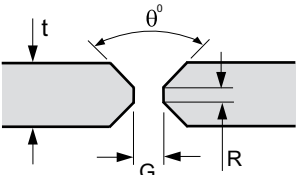
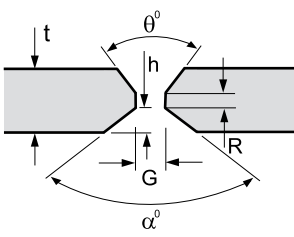
APPENDIX 2

REFERENCE SHEETS FOR SPECIAL STRUCTURAL DETAILS

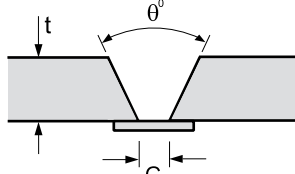
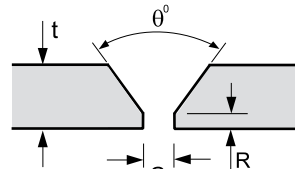
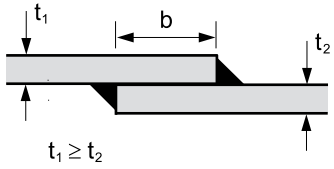
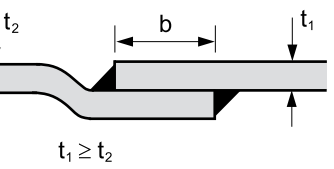
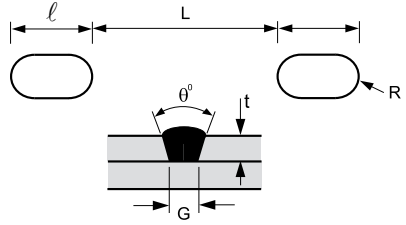
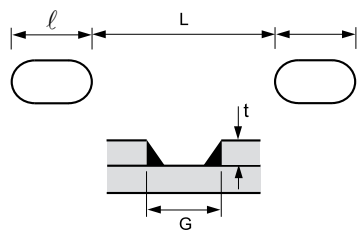
1 Contents

1.1 General

1.1.1 This appendix includes the reference sheets for special structural details, as referred to in Sec 2.

ALL LONGITUDINALLY FRAMED SIDE SHIPS

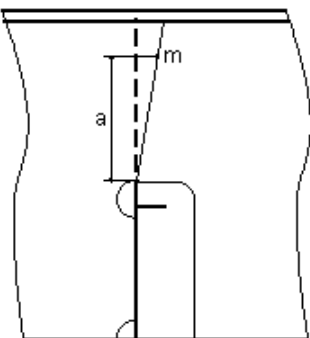
AREA 1: Side between 0,7T_B and 1,15T from the baseline	Connection of side longitudinal ordinary stiffeners with transverse primary supporting members - No collar plate	Sheet 1.1
<div style="display: flex; align-items: center;">  <div style="margin-left: 20px;"> <p>t_w = web thickness of transverse primary supporting member</p> </div> </div>		
SCANTLINGS:	FATIGUE:	
Net sectional area of the web stiffener according to Ch 4, Sec 3, 4.7.	Fatigue check not required.	
CONSTRUCTION:	NDE:	
<ul style="list-style-type: none"> ● Web stiffener not compulsory. When fitted, its misalignment m with the web of the side longitudinal $< a / 50$. ● <i>Cut-outs in the web free of sharps notches.</i> ● Gap between web and side longitudinal to be not greater than 4 mm. 	Visual examination 100%.	
WELDING AND MATERIALS:		
<p>Welding requirements:</p> <ul style="list-style-type: none"> - <i>continuous fillet welding along the connection of web with side longitudinal,</i> - <i>throat thickness according to Ch 11, Sec 1, [2.3.7], in case of gap g greater than 2 mm increase the throat thickness by $0,7(g-2)$ mm,</i> - weld around the cuts in the web at the connection with the longitudinal and the side shell, - avoid burned notches on web. 		

ALL LONGITUDINALLY FRAMED SIDE SHIPS

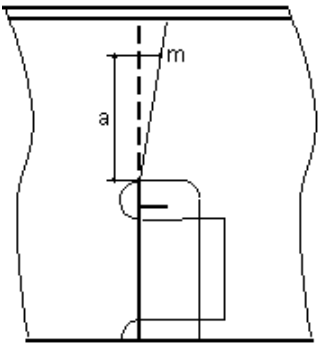
AREA 1: Side between 0,7T_B and 1,15T from the baseline	Connection of side longitudinal ordinary stiffeners with transverse primary supporting members - One collar plate	Sheet 1.2
<div style="display: flex; align-items: center;">  <div style="margin-left: 20px;"> <p>t_w = web thickness of transverse primary supporting member</p> <p>t_{cp} = collar plate thickness</p> </div> </div>		
SCANTLINGS:		FATIGUE:
Net sectional area of the web stiffener according to Ch 4, Sec 3, 4.7.		Fatigue check not required.
CONSTRUCTION:		NDE:
<ul style="list-style-type: none"> • Web stiffener not compulsory. When fitted, its misalignment m with the web of the side longitudinal $< a / 50$. • Misalignment between web and collar plate $\leq t_{cp}$. • <i>Cut-outs in the web free of sharps notches.</i> • Gap between web and side longitudinal and between collar plate and side longitudinal to be not greater than 4 mm. 		Visual examination 100%.
WELDING AND MATERIALS:		
<ul style="list-style-type: none"> • <i>Welding requirements:</i> <ul style="list-style-type: none"> - <i>continuous fillet welding along the connection of web and collar plate with side longitudinal and at the lap joint between web and collar plate,</i> - <i>throat thickness according to Ch 11, Sec 1, [2.3.7], in case of gap g greater than 2 mm increase the throat thickness by $0,7(g-2)$ mm,</i> - <i>weld around the cuts in the web at the connection with the longitudinal and the side shell,</i> - <i>avoid burned notches on web.</i> • Fillet welding of overlapped joint to be done all around. 		

ALL LONGITUDINALLY FRAMED SIDE SHIPS

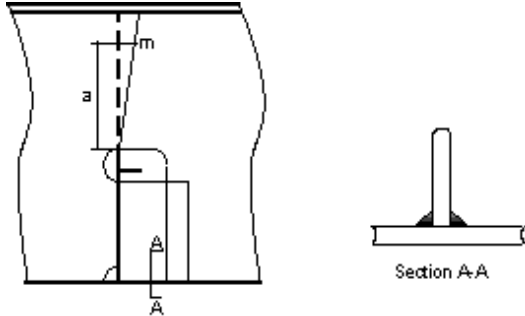
AREA 1: Side between 0,7T _B and 1,15T from the baseline	Connection of side longitudinal ordinary stiffeners with transverse primary supporting members - One large collar plate	Sheet 1.3
 <p style="text-align: center; margin-top: 10px;"> t_w = web thickness of transverse primary supporting member t_{cp} = collar plate thickness </p>		
SCANTLINGS:	FATIGUE:	
Net sectional area of the web stiffener according to Ch 4, Sec 3, [4.7].	Fatigue check not required.	
CONSTRUCTION:	NDE:	
<ul style="list-style-type: none"> • Web stiffener not compulsory. When fitted, its misalignment m with the web of the side longitudinal $< a / 50$. • Misalignment between web and collar plate $\leq t_{cp}$. • <i>Cut-outs in the web free of sharps notches.</i> • Gap between web and side longitudinal and between collar plate and side longitudinal to be not greater than 4 mm. 	Visual examination 100%.	
WELDING AND MATERIALS:		
<ul style="list-style-type: none"> • Welding requirements: <ul style="list-style-type: none"> - <i>continuous fillet welding along the connection of web and collar plate with side longitudinal and at the lap joint between web and collar plate,</i> - <i>throat thickness according to Ch 11, Sec 1, [2.3.7], in case of gap g greater than 2 mm increase the throat thickness by $0,7(g-2)$ mm,</i> - T joint connection of collar plate with side shell: see section A-A, - weld around the cuts in the web at the connection with the longitudinal and the side shell, - <i>avoid burned notches on web.</i> • Fillet welding of overlapped joint to be done all around. 		

ALL LONGITUDINALLY FRAMED SIDE SHIPS

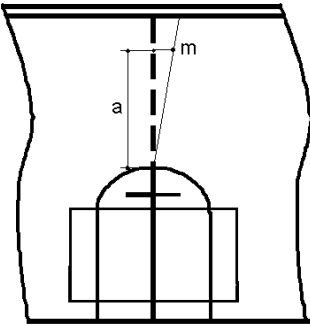
AREA 1: Side between 0,7T _B and 1,15T from the baseline	Connection of side longitudinal ordinary stiffeners with transverse primary supporting members - Two collar plates	Sheet 1.4
<div style="display: flex; align-items: center;">  <div style="margin-left: 20px;"> <p>t_w = web thickness of transverse primary supporting member</p> <p>t_{cp} = collar plate thickness</p> </div> </div>		
SCANTLINGS:	FATIGUE:	
Net sectional area of the web stiffener according to Ch 4, Sec 3, [4.7].	Fatigue check not required.	
CONSTRUCTION:	NDE:	
<ul style="list-style-type: none"> • Web stiffener not compulsory. When fitted, its misalignment m with the web of the side longitudinal $< a / 50$. • Misalignment between collar plates across the side longitudinal $\leq t_{cp} / 2$. • <i>Cut-outs in the web free of sharps notches.</i> • Gap between collar plates and side longitudinal to be not greater than 4 mm. 	Visual examination 100%.	
WELDING AND MATERIALS:		
<ul style="list-style-type: none"> • Welding requirements: <ul style="list-style-type: none"> - <i>continuous fillet welding along the connection of collar plates with side longitudinal and at the lap joint between web and collar plates,</i> - <i>throat thickness according to Ch 11, Sec 1, [2.3.7], in case of gap g greater than 2 mm increase the throat thickness by $0,7(g-2)$ mm,</i> - avoid burned notches on web. • Fillet welding of overlapped joint to be done all around. 		

ALL LONGITUDINALLY FRAMED SIDE SHIPS

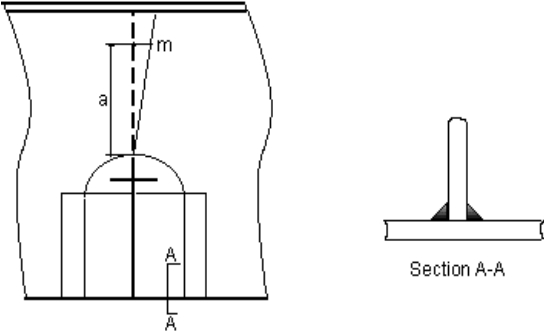
AREA 1: Side between 0,7T _B and 1,15T from the baseline	Connection of side longitudinal ordinary stiffeners with transverse primary supporting members - Two large collar plates	Sheet 1.5
<div style="text-align: center;">  <p data-bbox="480 712 1110 786"> t_w = web thickness of transverse primary supporting member t_{CP} = collar plate thickness </p> </div>		
SCANTLINGS:	FATIGUE:	
Net sectional area of the web stiffener according to Ch 4, Sec 3, [4.7].	Fatigue check not required.	
CONSTRUCTION:	NDE:	
<ul style="list-style-type: none"> • Web stiffener not compulsory. When fitted, its misalignment m with the web of the side longitudinal $< a / 50$. • Misalignment between collar plates across the side longitudinal $\leq t_{CP} / 2$. • <i>Cut-outs in the web free of sharps notches.</i> • Gap between collar plates and side longitudinal to be not greater than 4 mm. 	Visual examination 100%.	
WELDING AND MATERIALS:		
<ul style="list-style-type: none"> • Welding requirements: <ul style="list-style-type: none"> - <i>continuous fillet welding along the connection of collar plates with side longitudinal and at the lap joint between web and collar plates,</i> - <i>throat thickness according to Ch 11, Sec 1, [2.3.7], in case of gap g greater than 2 mm increase the throat thickness by $0,7(g-2)$ mm,</i> - T joint connection of collar plates with side shell: see section A-A, - avoid burned notches on web. • Fillet welding of overlapped joint to be done all around. 		

ALL LONGITUDINALLY FRAMED SIDE SHIPS

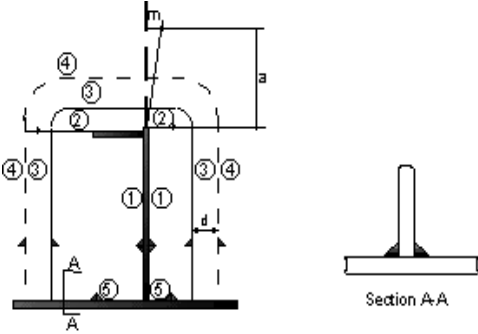
AREA 1: Side between 0,7T_B and 1,15T from the baseline	Watertight connection of side longitudinal ordinary stiffeners with watertight side diaphragms or transverse bulkheads – Example of connection with lugs	Sheet 1.6
<div style="text-align: center;">  <p style="text-align: center;">t_w = transverse bulkhead web thickness t_l = lug thickness</p> </div>		
SCANTLINGS: <ul style="list-style-type: none"> • $d = 30 \div 60$ mm. • $t_l \geq t_w$. 	FATIGUE: Fatigue check not required.	
CONSTRUCTION: <ul style="list-style-type: none"> • Web stiffener not compulsory. When fitted, its misalignment m with the web of the side longitudinal $< a / 50$. • Misalignment between lugs across the side longitudinal $\leq t_l / 2$. • Misalignment at the butts within lug parts $\leq t_l / 5$. • Gap between bulkhead plating and lugs to be not greater than 4 mm. 	NDE: <ul style="list-style-type: none"> • Visual examination 100%. • Magnetic particle or dye penetrant examination: when deemed necessary depending on the quality of the lap joint weld. 	
WELDING AND MATERIALS: Welding requirements: <ul style="list-style-type: none"> - <i>continuous fillet welding along the connection of lugs with the side longitudinal and at the lap joints between web and lugs,</i> - <i>throat thickness according to Ch 11, Sec 1, [2.3.7], in case of gap g greater than 2 mm increase the throat thickness by $0,7(g-2)$ mm,</i> - T joint connection of collar plates with side shell: see section A-A, - welding sequence: ① to ⑤ (see sketch). 		

ALL LONGITUDINALLY FRAMED SIDE SHIPS

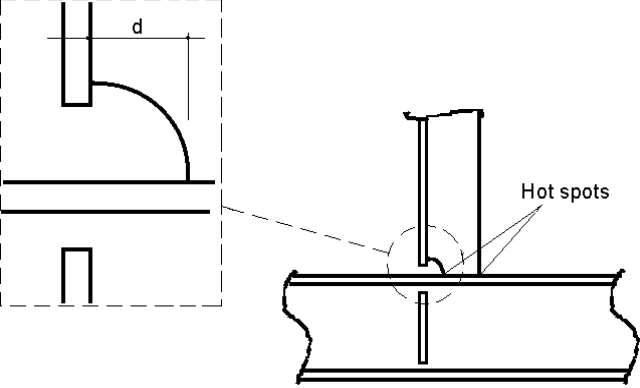
AREA 1: Side between 0,7T _B and 1,15T from the baseline	Connection of side longitudinal ordinary stiffeners with stiffeners of transverse primary supporting members - No bracket	Sheet 1.7
<div style="display: flex; align-items: center;">  <div style="margin-left: 20px;"> <p>$t =$ minimum thickness between those of:</p> <ul style="list-style-type: none"> - web of side longitudinal, - stiffener of transverse primary supporting member. </div> </div>		
SCANTLINGS:	FATIGUE:	
<p>d to be as small as possible, maximum 35 mm recommended.</p>	<p>Fatigue check to be carried out for $L \geq 90$ m:</p> <ul style="list-style-type: none"> • with non-watertight collar plate: <ul style="list-style-type: none"> $K_b = 1,30$ $K_r = 1,65$ • with full collar plate (watertight): <ul style="list-style-type: none"> $K_b = 1,25$ $K_r = 1,50$ 	
CONSTRUCTION:	NDE:	
<p>Misalignment (measured between the outer edges) between longitudinal and web stiffener to be in general equal to or less than 0,7 t. For bulbs, a misalignment equal to 0,8 t may generally be accepted.</p>	<p>Visual examination 100%.</p>	
WELDING AND MATERIALS:		
<p>Welding requirements:</p> <ul style="list-style-type: none"> - continuous fillet welding, - throat thickness = $0,45 t_w$, where t_w is the web stiffener thickness, - weld around the stiffener's toes, - fair shape of fillet at toes in longitudinal direction. 		

ALL LONGITUDINALLY FRAMED SIDE SHIPS

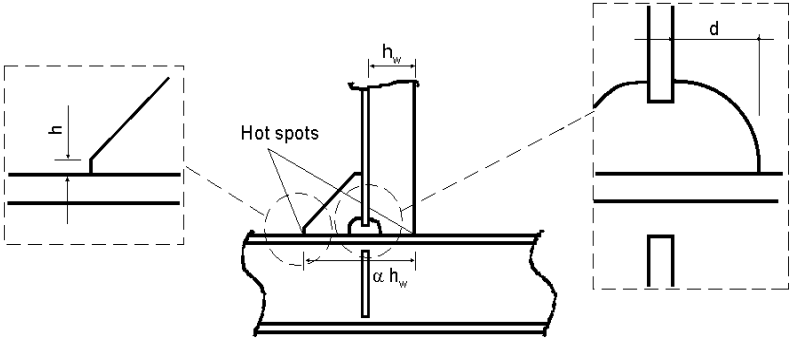
AREA 1: Side between 0,7T _B and 1,15T from the baseline	Connection of side longitudinal ordinary stiffeners with stiffeners of transverse primary supporting members - One bracket	Sheet 1.8
 <p style="text-align: right;">t = minimum thickness among those of the connected elements</p>		
<p>SCANTLINGS:</p> <ul style="list-style-type: none"> • $\alpha \geq 2$. • Bracket to be symmetric. • h as necessary to allow the required fillet throat size, but ≤ 15 mm. • d to be as small as possible, maximum 35 mm recommended. • Thickness of the bracket to be not less than that of web stiffener. 	<p>FATIGUE:</p> <p>Fatigue check to be carried out for $L \geq 90$ m:</p> <ul style="list-style-type: none"> • with non-watertight collar plate: <ul style="list-style-type: none"> – for $2 \leq \alpha < 2,5$ $K_h = 1,20$ <li style="text-align: right;">$K_r = 1,40$ – for $\alpha \geq 2,5$ $K_h = 1,15$ <li style="text-align: right;">$K_r = 1,40$ • with full collar plate (watertight): <ul style="list-style-type: none"> – for $2 \leq \alpha < 2,5$ $K_h = 1,15$ <li style="text-align: right;">$K_r = 1,32$ – for $\alpha \geq 2,5$ $K_h = 1,10$ <li style="text-align: right;">$K_r = 1,32$ 	
<p>CONSTRUCTION:</p> <p>Misalignment (measured between the outer edges) between longitudinal, web stiffener and bracket to be in general equal to or less than $0,7 t$. For bulbs, a misalignment equal to $0,8 t$ may generally be accepted.</p>	<p>NDE:</p> <p>Visual examination 100%.</p>	
<p>WELDING AND MATERIALS:</p> <p>Welding requirements:</p> <ul style="list-style-type: none"> - continuous fillet welding, - throat thickness = $0,45 t_w$, where t_w is the web stiffener thickness, - weld around the stiffener's toes, - fair shape of fillet at toes in longitudinal direction. 		

ALL LONGITUDINALLY FRAMED SIDE SHIPS

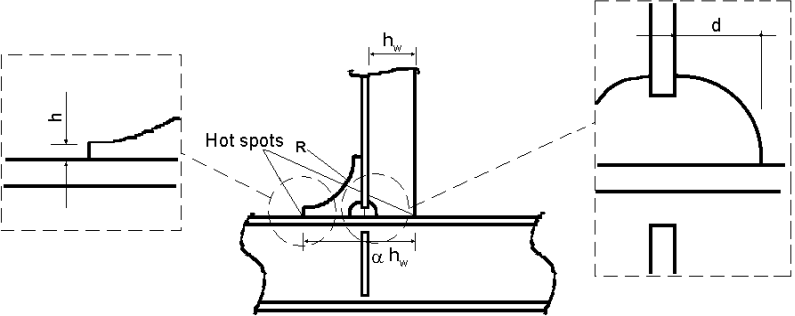
AREA 1: Side between 0,7T _B and 1,15T from the baseline	Connection of side longitudinal ordinary stiffeners with stiffeners of transverse primary supporting members - One radiused bracket	Sheet 1.9
 <p style="text-align: center;">t = minimum thickness among those of the connected elements</p>		
<p>SCANTLINGS:</p> <ul style="list-style-type: none"> • $\alpha \geq 2$. • Bracket to be symmetric. • $R \geq 1,5 (\alpha - 1) h_w$ • h as necessary to allow the required fillet throat size, but ≤ 15 mm. • d to be as small as possible, maximum 35 mm recommended. • Thickness of the bracket to be not less than that of web stiffener. 	<p>FATIGUE:</p> <p>Fatigue check to be carried out for $L \geq 90$ m:</p> <ul style="list-style-type: none"> • with non-watertight collar plate: <ul style="list-style-type: none"> - for $2 \leq \alpha < 2,5$ $K_h = 1,20$ $K_t = 1,40$ - for $\alpha \geq 2,5$ $K_h = 1,15$ $K_t = 1,40$ • with full collar plate (watertight): <ul style="list-style-type: none"> - for $2 \leq \alpha < 2,5$ $K_h = 1,15$ $K_t = 1,32$ - for $\alpha \geq 2,5$ $K_h = 1,10$ $K_t = 1,32$ 	
<p>CONSTRUCTION:</p> <p>Misalignment (measured between the outer edges) between longitudinal, web stiffener and bracket to be in general equal to or less than $0,7 t$. For bulbs, a misalignment equal to $0,8 t$ may generally be accepted.</p>	<p>NDE:</p> <p>Visual examination 100%.</p>	
<p>WELDING AND MATERIALS:</p> <p>Welding requirements:</p> <ul style="list-style-type: none"> - continuous fillet welding, - throat thickness = $0,45 t_w$, where t_w is the web stiffener thickness, - weld around the stiffener's toes, - fair shape of fillet at toes in longitudinal direction. 		

ALL LONGITUDINALLY FRAMED SIDE SHIPS

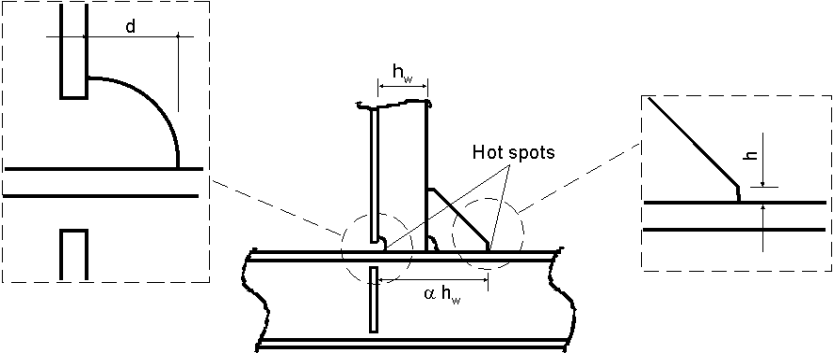
AREA 1: Side between 0,7T_B and 1,15T from the baseline	Connection of side longitudinal ordinary stiffeners with stiffeners of transverse primary supporting members - One bracket	Sheet 1.10
 <p style="text-align: center;">t = minimum thickness among those of the connected elements</p>		
<p>SCANTLINGS:</p> <ul style="list-style-type: none"> • $\alpha \geq 2$. • Bracket to be symmetric. • h as necessary to allow the required fillet throat size, but ≤ 15 mm. • d to be as small as possible, maximum 35 mm recommended. • Thickness of the bracket to be not less than that of web stiffener. 	<p>FATIGUE:</p> <p>Fatigue check to be carried out for $L \geq 90$ m:</p> <ul style="list-style-type: none"> • with non-watertight collar plate: <ul style="list-style-type: none"> - for $2 \leq \alpha < 2,5$ $K_h = 1,20$ <li style="text-align: right;">$K_\ell = 1,40$ - for $\alpha \geq 2,5$ $K_h = 1,15$ <li style="text-align: right;">$K_\ell = 1,40$ • with full collar plate (watertight): <ul style="list-style-type: none"> - for $2 \leq \alpha < 2,5$ $K_h = 1,15$ <li style="text-align: right;">$K_\ell = 1,32$ - for $\alpha \geq 2,5$ $K_h = 1,10$ <li style="text-align: right;">$K_\ell = 1,32$ 	
<p>CONSTRUCTION:</p> <p>Misalignment (measured between the outer edges) between longitudinal, web stiffener and bracket to be in general equal to or less than $0,7 t$. For bulbs, a misalignment equal to $0,8 t$ may generally be accepted.</p>	<p>NDE:</p> <p>Visual examination 100%.</p>	
<p>WELDING AND MATERIALS:</p>		
<p>Welding requirements:</p> <ul style="list-style-type: none"> - continuous fillet welding, - throat thickness = $0,45 t_w$, where t_w is the web stiffener thickness, - weld around the stiffener's toes, - fair shape of fillet at toes in longitudinal direction. 		

ALL LONGITUDINALLY FRAMED SIDE SHIPS

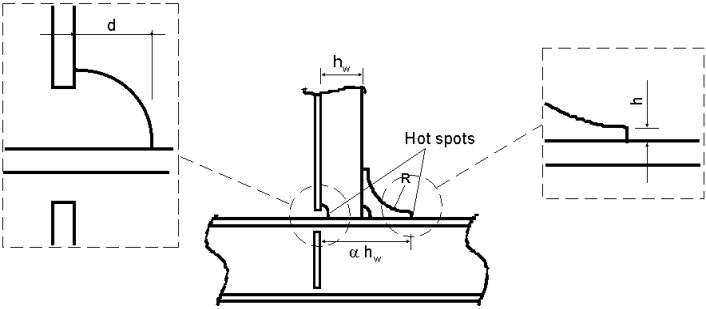
AREA 1: Side between 0,7T_B and 1,15T from the baseline	Connection of side longitudinal ordinary stiffeners with stiffeners of transverse primary supporting members - One radiused bracket	Sheet 1.11
 <p style="text-align: center;">t = minimum thickness among those of the connected elements</p>		
<p>SCANTLINGS:</p> <ul style="list-style-type: none"> • $\alpha \geq 2$ • Bracket to be symmetric. • $R \geq 1,5 (\alpha - 1) h_w$ • h as necessary to allow the required fillet throat size, but ≤ 15 mm. • d to be as small as possible, maximum 35 mm recommended. • Thickness of the bracket to be not less than that of web stiffener. 	<p>FATIGUE:</p> <p>Fatigue check to be carried out for $L \geq 90$ m:</p> <ul style="list-style-type: none"> • with non-watertight collar plate: <ul style="list-style-type: none"> - for $2 \leq \alpha < 2,5$ $K_h = 1,20$ <li style="text-align: right;">$K_\ell = 1,40$ - for $\alpha \geq 2,5$ $K_h = 1,15$ <li style="text-align: right;">$K_\ell = 1,40$ • with full collar plate (watertight): <ul style="list-style-type: none"> - for $2 \leq \alpha < 2,5$ $K_h = 1,15$ <li style="text-align: right;">$K_\ell = 1,32$ - for $\alpha \geq 2,5$ $K_h = 1,10$ <li style="text-align: right;">$K_\ell = 1,32$ 	
<p>CONSTRUCTION:</p> <p>Misalignment (measured between the outer edges) between longitudinal, web stiffener and bracket to be in general equal to or less than $0,7 t$. For bulbs, a misalignment equal to $0,8 t$ may generally be accepted.</p>	<p>NDE:</p> <p>Visual examination 100%.</p>	
<p>WELDING AND MATERIALS:</p> <p>Welding requirements:</p> <ul style="list-style-type: none"> - continuous fillet welding, - throat thickness = $0,45 t_w$, where t_w is the web stiffener thickness, - weld around the stiffener's toes, - fair shape of fillet at toes in longitudinal direction. 		

ALL LONGITUDINALLY FRAMED SIDE SHIPS

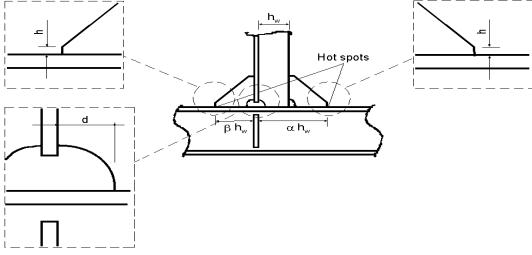
AREA 1: Side between 0,7T _B and 1,15T from the baseline	Connection of side longitudinal ordinary stiffeners with stiffeners of transverse primary supporting members - Two brackets	Sheet 1.12
 <p style="text-align: center;">t = minimum thickness among those of the connected elements</p>		
<p>SCANTLINGS:</p> <ul style="list-style-type: none"> • $\alpha \geq 2$. • $\beta \geq 1$. • Brackets to be symmetric. • h as necessary to allow the required fillet throat size, but ≤ 15 mm. • d to be as small as possible, maximum 35 mm recommended. • Thickness of the brackets to be not less than that of web stiffener. 	<p>FATIGUE:</p> <p>Fatigue check to be carried out for $L \geq 90$ m:</p> <ul style="list-style-type: none"> • with non-watertight collar plate: <ul style="list-style-type: none"> - for $2 \leq \alpha < 2,5$ $K_h = 1,20$ $K_\ell = 1,40$ - for $\alpha \geq 2,5$ $K_h = 1,15$ $K_\ell = 1,40$ • with full collar plate (watertight): <ul style="list-style-type: none"> - for $2 \leq \alpha < 2,5$ $K_h = 1,15$ $K_\ell = 1,32$ - for $\alpha \geq 2,5$ $K_h = 1,10$ $K_\ell = 1,32$ 	
<p>CONSTRUCTION:</p> <p>Misalignment (measured between the outer edges) between longitudinal, web stiffener and bracket to be in general equal to or less than 0,7 t. For bulbs, a misalignment equal to 0,8 t may generally be accepted.</p>	<p>NDE:</p> <p>Visual examination 100%.</p>	
<p>WELDING AND MATERIALS:</p> <ul style="list-style-type: none"> • Welding requirements: <ul style="list-style-type: none"> - continuous fillet welding, - throat thickness = $0,45 t_w$, where t_w is the web stiffener thickness, - weld around the stiffener's toes, - fair shape of fillet at toes in longitudinal direction. • Material requirements: <ul style="list-style-type: none"> - material of brackets to be the same of longitudinals. 		

ALL LONGITUDINALLY FRAMED SIDE SHIPS

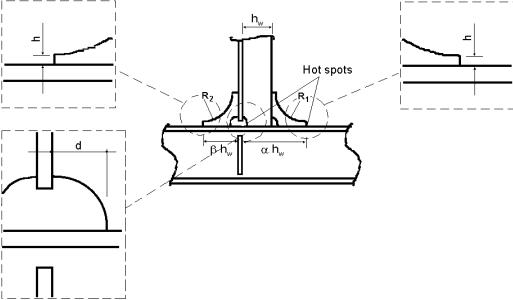
AREA 1: Side between 0,7T _B and 1,15T from the baseline	Connection of side longitudinal ordinary stiffeners with stiffeners of transverse primary supporting members - Two radiused brackets	Sheet 1.13
 <p style="text-align: center;">t = minimum thickness among those of the connected elements</p>		
SCANTLINGS:	FATIGUE:	
<ul style="list-style-type: none"> • $\alpha \geq 2$. • $\beta \geq 1$. • Brackets to be symmetric. • $R_1 \geq 1,5 (\alpha - 1) h_w$ • $R_2 \geq 1,5 \beta h_w$ • h as necessary to allow the required fillet throat size, but ≤ 15 mm. • d to be as small as possible, maximum 35 mm recommended. • Thickness of the brackets to be not less than that of web stiffener. 	Fatigue check to be carried out for $L \geq 90$ m: <ul style="list-style-type: none"> • with non-watertight collar plate: <ul style="list-style-type: none"> – for $2 \leq \alpha < 2,5$ $K_h = 1,20$ <li style="text-align: right;">$K_\ell = 1,40$ – for $\alpha \geq 2,5$ $K_h = 1,15$ <li style="text-align: right;">$K_\ell = 1,40$ • with full collar plate (watertight): <ul style="list-style-type: none"> – for $2 \leq \alpha < 2,5$ $K_h = 1,15$ <li style="text-align: right;">$K_\ell = 1,32$ – for $\alpha \geq 2,5$ $K_h = 1,10$ <li style="text-align: right;">$K_\ell = 1,32$ 	
CONSTRUCTION:	NDE:	
Misalignment (measured between the outer edges) between longitudinal, web stiffener and bracket to be in general equal to or less than 0,7 t. For bulbs, a misalignment equal to 0,8 t may generally be accepted.	Visual examination 100%.	
WELDING AND MATERIALS:		
<ul style="list-style-type: none"> • Welding requirements: <ul style="list-style-type: none"> - continuous fillet welding, - throat thickness = $0,45 t_w$, where t_w is the web stiffener thickness, - weld around the stiffener's toes, - fair shape of fillet at toes in longitudinal direction. • Material requirements: <ul style="list-style-type: none"> - material of brackets to be the same of longitudinals. 		

AUXILIARY (CARGO TANK REGIONS)

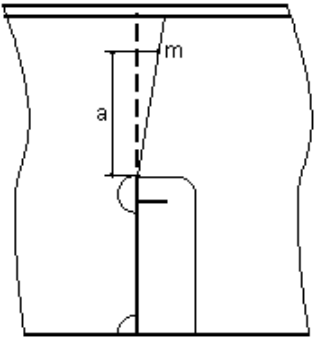
AREA 2: Inner side and longitudinal bulkheads above 0,5H	Connection of inner side or bulkhead longitudinal ordinary stiffeners with transverse primary supporting members - No collar plate	Sheet 2.1
<div style="display: flex; align-items: center;">  <div style="margin-left: 20px;"> <p>t_w = web thickness of transverse primary supporting member</p> </div> </div>		
SCANTLINGS:	FATIGUE:	
Net sectional area of the web stiffener according to Ch 4, Sec 3, 4.7.	Fatigue check not required.	
CONSTRUCTION:	NDE:	
<ul style="list-style-type: none"> • Web stiffener not compulsory. When fitted, its misalignment m with the web of the longitudinal $< a / 50$. • <i>Cut-outs in the web free of sharps notches.</i> • Gap between web and longitudinal to be not greater than 4 mm. 	Visual examination 100%.	
WELDING AND MATERIALS:		
<p>Welding requirements:</p> <ul style="list-style-type: none"> - <i>continuous fillet welding along the connection of web with longitudinal,</i> - <i>throat thickness according to Ch 11, Sec 1, 2.3.7, in case of gap g greater than 2 mm increase the throat thickness by $0,7(g-2)$ mm,</i> - weld around the cuts in the web at the connection with the longitudinal and the plating, - avoid burned notches on web. 		

AUXILIARY (CARGO TANK REGIONS)

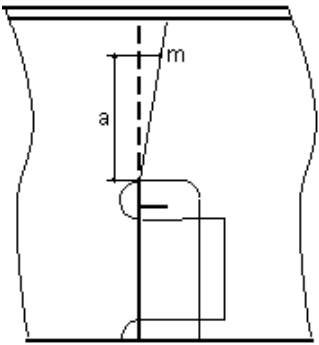
AREA 2: Inner side and longitudinal bulkheads above 0,5H	Connection of inner side or bulkhead longitudinal ordinary stiffeners with transverse primary supporting members - One collar plate	Sheet 2.2
<div style="display: flex; align-items: center;">  <div style="margin-left: 20px;"> <p>t_w = web thickness of transverse primary supporting member</p> <p>t_{cp} = collar plate thickness</p> </div> </div>		
SCANTLINGS:		FATIGUE:
Net sectional area of the web stiffener according to Ch 4, Sec 3, 4.7.		Fatigue check not required.
CONSTRUCTION:		NDE:
<ul style="list-style-type: none"> • Web stiffener not compulsory. When fitted, its misalignment m with the web of the longitudinal $< a / 50$. • Misalignment between web and collar plate $\leq t_{cp}$. • <i>Cut-outs in the web free of sharps notches.</i> • Gap between web and longitudinal and between collar plate and longitudinal to be not greater than 4 mm. 		Visual examination 100%.
WELDING AND MATERIALS:		
<ul style="list-style-type: none"> • <i>Welding requirements:</i> <ul style="list-style-type: none"> - <i>continuous fillet welding along the connection of web and collar plate with longitudinal and at the lap joint between web and collar plate,</i> - <i>throat thickness according to Ch 11, Sec 1, [2.3.7], in case of gap g greater than 2 mm increase the throat thickness by $0,7(g-2)$ mm,</i> - <i>weld around the cuts in the web at the connection with the longitudinal and the plating,</i> - <i>avoid burned notches on web.</i> • Fillet welding of overlapped joint to be done all around. 		

AUXILIARY (CARGO TANK REGIONS)

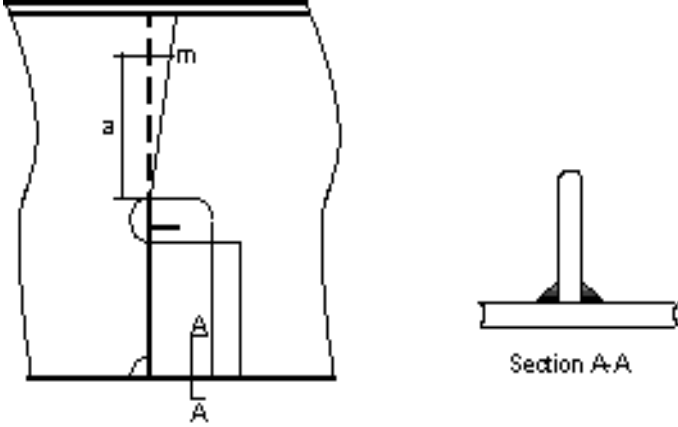
AREA 2: Inner side and longitudinal bulkheads above 0,5H	Connection of inner side or bulkhead longitudinal ordinary stiffeners with transverse primary supporting members - One large collar plate	Sheet 2.3
 <p style="text-align: center;">t_w = web thickness of transverse primary supporting member t_{cp} = collar plate thickness</p>		
SCANTLINGS:	FATIGUE:	
Net sectional area of the web stiffener according to Ch 4, Sec 3, [4.7].	Fatigue check not required.	
CONSTRUCTION:	NDE:	
<ul style="list-style-type: none"> • Web stiffener not compulsory. When fitted, its misalignment m with the web of the longitudinal $< a / 50$. • Misalignment between web and collar plate $\leq t_{cp}$. • <i>Cut-outs in the web free of sharps notches.</i> • Gap between web and longitudinal and between collar plate and longitudinal to be not greater than 4 mm. 	Visual examination 100%.	
WELDING AND MATERIALS:		
<ul style="list-style-type: none"> • Welding requirements: <ul style="list-style-type: none"> - <i>continuous fillet welding along the connection of web and collar plate with longitudinal and at the lap joint between web and collar plate,</i> - <i>throat thickness according to Ch 11, Sec 1, [2.3.7], in case of gap g greater than 2 mm increase the throat thickness by $0,7(g-2)$ mm,</i> - T joint connection of collar plate with the plating: see section A-A, - weld around the cuts in the web at the connection with the longitudinal and the plating, - <i>avoid burned notches on web.</i> • Fillet welding of overlapped joint to be done all around. 		

AUXILIARY (CARGO TANK REGIONS)

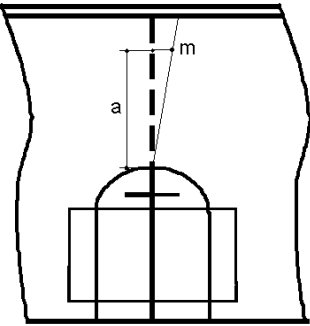
AREA 2: Inner side and longitudinal bulkheads above 0,5H	Connection of inner side or bulkhead longitudinal ordinary stiffeners with transverse primary supporting members - Two collar plates	Sheet 2.4
<div style="display: flex; align-items: flex-start;"> <div style="flex: 1;">  </div> <div style="flex: 1; padding-left: 20px;"> <p>t_w = web thickness of transverse primary supporting member</p> <p>t_{CP} = collar plate thickness</p> </div> </div>		
SCANTLINGS:		FATIGUE:
Net sectional area of the web stiffener according to Ch 4, Sec 3, [4.7].		Fatigue check not required.
CONSTRUCTION:		NDE:
<ul style="list-style-type: none"> • Web stiffener not compulsory. When fitted, its misalignment m with the web of the longitudinal $< a / 50$. • Misalignment between collar plates across the longitudinal $\leq t_{CP} / 2$. • <i>Cut-outs in the web free of sharps notches.</i> • Gap between collar plates and longitudinal to be not greater than 4 mm. 		Visual examination 100%.
WELDING AND MATERIALS:		
<ul style="list-style-type: none"> • Welding requirements: <ul style="list-style-type: none"> - <i>continuous fillet welding along the connection of collar plates with longitudinal and at the lap joint between web and collar plates,</i> - <i>throat thickness according to Ch 11, Sec 1, [2.3.7], in case of gap g greater than 2 mm increase the throat thickness by $0,7(g-2)$ mm,</i> - avoid burned notches on web. • Fillet welding of overlapped joint to be done all around. 		

AUXILIARY (CARGO TANK REGIONS)

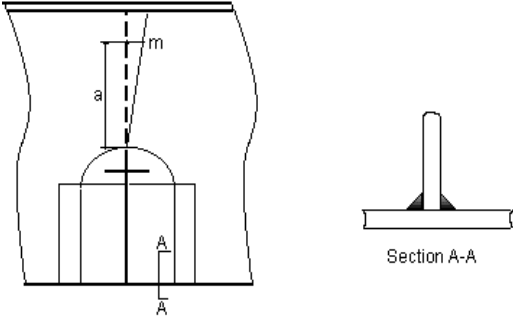
AREA 2: Inner side and longitudinal bulkheads above 0,5H	Connection of inner side or bulkhead longitudinal ordinary stiffeners with transverse primary supporting members - Two large collar plates	Sheet 2.5
<div style="text-align: center;">  <p data-bbox="480 696 1110 770"> t_w = web thickness of transverse primary supporting member t_{CP} = collar plate thickness </p> </div>		
SCANTLINGS:	FATIGUE:	
Net sectional area of the web stiffener according to Ch 4, Sec 3, [4.7].	Fatigue check not required.	
CONSTRUCTION:	NDE:	
<ul style="list-style-type: none"> • Web stiffener not compulsory. When fitted, its misalignment m with the web of the longitudinal $< a / 50$. • Misalignment between collar plates across the longitudinal $\leq t_{CP} / 2$. • <i>Cut-outs in the web free of sharps notches.</i> • Gap between collar plates and longitudinal to be not greater than 4 mm. 	Visual examination 100%.	
WELDING AND MATERIALS:		
<ul style="list-style-type: none"> • Welding requirements: <ul style="list-style-type: none"> - <i>continuous fillet welding along the connection of collar plates with longitudinal and at the lap joint between web and collar plates,</i> - <i>throat thickness according to Ch 11, Sec 1, [2.3.7], in case of gap g greater than 2 mm increase the throat thickness by $0,7(g-2)$ mm,</i> - T joint connection of collar plates with the plating: see section A-A, - avoid burned notches on web. • Fillet welding of overlapped joint to be done all around. 		

AUXILIARY (CARGO TANK REGIONS)

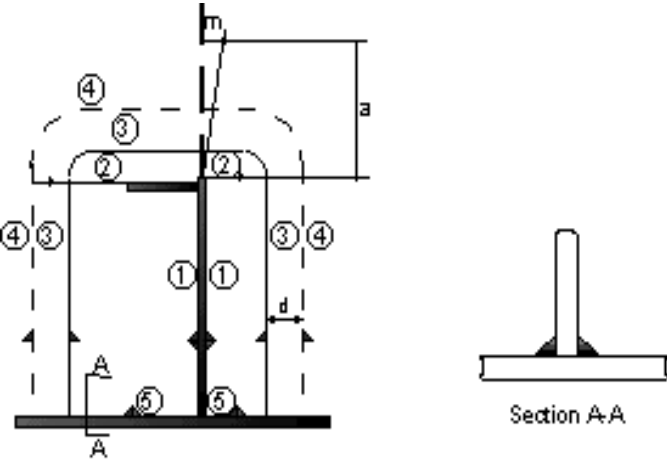
AREA 2: Inner side and longitudinal bulkheads above 0,5H	Watertight connection of inner side or bulkhead longitudinal ordinary stiffeners with watertight side diaphragms or transverse bulkheads – Example of connection with lugs	Sheet 2.6
 <p style="text-align: center;">t_w = transverse bulkhead web thickness t_l = lug thickness</p>		
SCANTLINGS:	FATIGUE:	
<ul style="list-style-type: none"> • $d = 30 \div 60$ mm. • $t_l \geq t_w$. 	Fatigue check not required.	
CONSTRUCTION:	NDE:	
<ul style="list-style-type: none"> • Web stiffener not compulsory. When fitted, its misalignment m with the web of the longitudinal $< a / 50$. • Misalignment between lugs across the longitudinal $\leq t_l / 2$. • Misalignment at the butts within lug parts $\leq t_l / 5$. • Gap between bulkhead plating and lugs to be not greater than 4 mm. 	<ul style="list-style-type: none"> • Visual examination 100%. • Magnetic particle or dye penetrant examination: when deemed necessary depending on the quality of the lap joint weld. 	
WELDING AND MATERIALS:		
<p>Welding requirements:</p> <ul style="list-style-type: none"> - <i>continuous fillet welding along the connection of lugs with the longitudinal and at the lap joints between web and lugs,</i> - <i>throat thickness according to Ch 11, Sec 1, [2.3.7], in case of gap g greater than 2 mm increase the throat thickness by $0,7(g-2)$ mm,</i> - T joint connection of collar plates with the plating: see section A-A, - welding sequence: ① to ⑤ (see sketch). 		

AUXILIARY (CARGO TANK REGIONS)

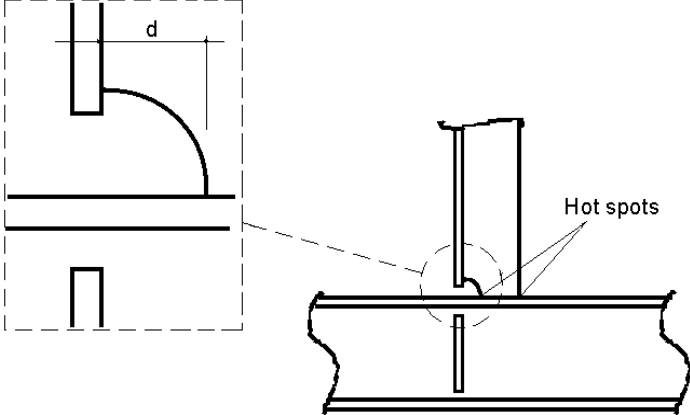
AREA 2: Inner side and longitudinal bulkheads above 0,5H	Connection of inner side or bulkhead longitudinal ordinary stiffeners with stiffeners of transverse primary supporting members - No bracket	Sheet 2.7
<div style="display: flex; align-items: center;">  <div style="margin-left: 20px;"> <p>$t =$ minimum thickness between those of:</p> <ul style="list-style-type: none"> - web of longitudinal, - stiffener of transverse primary supporting member. </div> </div>		
SCANTLINGS:	FATIGUE:	
d to be as small as possible, maximum 35 mm recommended.	Fatigue check to be carried out for $L \geq 90$ m: $K_b = 1,3$ $K_t = 1,65$	
CONSTRUCTION:	NDE:	
Misalignment (measured between the outer edges) between longitudinal and web stiffener to be in general equal to or less than $0,7 t$. For bulbs, a misalignment equal to $0,8 t$ may generally be accepted.	Visual examination 100%.	
WELDING AND MATERIALS:		
Welding requirements: <ul style="list-style-type: none"> - continuous fillet welding, - throat thickness = $0,45 t_w$, where t_w is the web stiffener thickness, - weld around the stiffener's toes, - fair shape of fillet at toes in longitudinal direction. 		

AUXILIARY (CARGO TANK REGIONS)

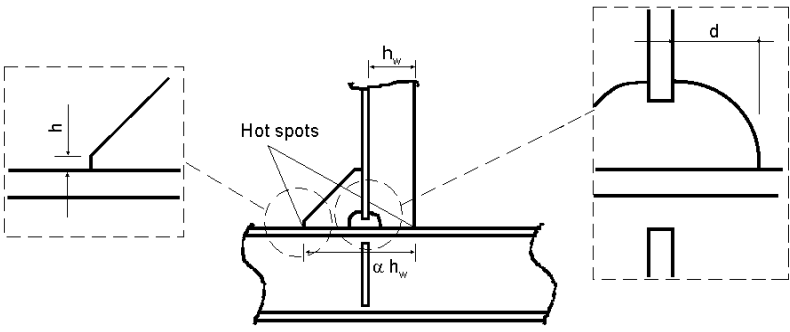
AREA 2: Inner side and longitudinal bulkheads above 0,5H	Connection of inner side or bulkhead longitudinal ordinary stiffeners with stiffeners of transverse primary supporting members - One bracket	Sheet 2.8
 <p style="text-align: center;">t = minimum thickness among those of the connected elements</p>		
<p>SCANTLINGS:</p> <ul style="list-style-type: none"> • $\alpha \geq 2$. • Bracket to be symmetric. • h as necessary to allow the required fillet throat size, but ≤ 15 mm. • d to be as small as possible, maximum 35 mm recommended. • Thickness of the bracket to be not less than that of web stiffener. 	<p>FATIGUE:</p> <p>Fatigue check to be carried out for $L \geq 90$ m:</p> <ul style="list-style-type: none"> • with non-watertight collar plate: <ul style="list-style-type: none"> – for $2 \leq \alpha < 2,5$ $K_h = 1,20$ $K_\ell = 1,40$ – for $\alpha \geq 2,5$ $K_h = 1,15$ $K_\ell = 1,40$ • with full collar plate (watertight): <ul style="list-style-type: none"> – for $2 \leq \alpha < 2,5$ $K_h = 1,15$ $K_\ell = 1,32$ – for $\alpha \geq 2,5$ $K_h = 1,10$ $K_\ell = 1,32$ 	
<p>CONSTRUCTION:</p> <p>Misalignment (measured between the outer edges) between longitudinal, web stiffener and bracket to be in general equal to or less than $0,7 t$. For bulbs, a misalignment equal to $0,8 t$ may generally be accepted.</p>	<p>NDE:</p> <p>Visual examination 100%.</p>	
<p>WELDING AND MATERIALS:</p> <p>Welding requirements:</p> <ul style="list-style-type: none"> - continuous fillet welding, - throat thickness = $0,45 t_w$, where t_w is the web stiffener thickness, - weld around the stiffener's toes, - fair shape of fillet at toes in longitudinal direction. 		

AUXILIARY (CARGO TANK REGIONS)

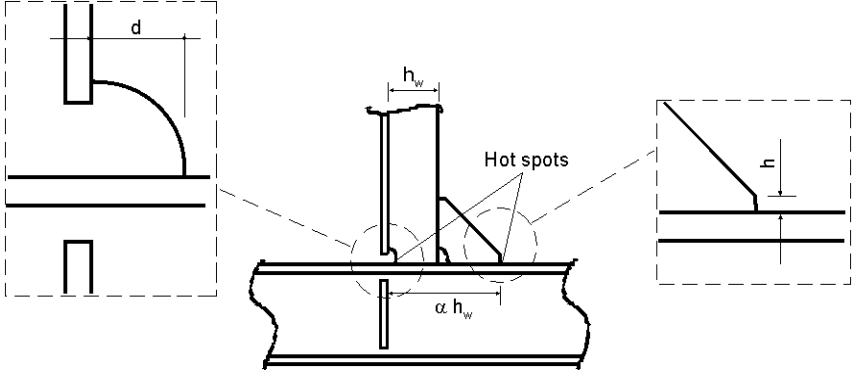
AREA 2: Inner side and longitudinal bulkheads above 0,5H	Connection of inner side or bulkhead longitudinal ordinary stiffeners with stiffeners of transverse primary supporting members - One bracket	Sheet 2.10
 <p style="text-align: center;">t = minimum thickness among those of the connected elements</p>		
<p>SCANTLINGS:</p> <ul style="list-style-type: none"> • $\alpha \geq 2$. • Bracket to be symmetric. • h as necessary to allow the required fillet throat size, but ≤ 15 mm. • d to be as small as possible, maximum 35 mm recommended. • Thickness of the bracket to be not less than that of web stiffener. 	<p>FATIGUE:</p> <p>Fatigue check to be carried out for $L \geq 90$ m:</p> <ul style="list-style-type: none"> • with non-watertight collar plate: <ul style="list-style-type: none"> – for $2 \leq \alpha < 2,5$ $K_h = 1,20$ <li style="padding-left: 150px;">$K_\ell = 1,40$ – for $\alpha \geq 2,5$ $K_h = 1,15$ <li style="padding-left: 150px;">$K_\ell = 1,40$ • with full collar plate (watertight): <ul style="list-style-type: none"> – for $2 \leq \alpha < 2,5$ $K_h = 1,15$ <li style="padding-left: 150px;">$K_\ell = 1,32$ – for $\alpha \geq 2,5$ $K_h = 1,10$ <li style="padding-left: 150px;">$K_\ell = 1,32$ 	
<p>CONSTRUCTION:</p> <p>Misalignment (measured between the outer edges) between longitudinal, web stiffener and bracket to be in general equal to or less than $0,7 t$. For bulbs, a misalignment equal to $0,8 t$ may generally be accepted.</p>	<p>NDE:</p> <p>Visual examination 100%.</p>	
<p>WELDING AND MATERIALS:</p> <p>Welding requirements:</p> <ul style="list-style-type: none"> - continuous fillet welding, - throat thickness = $0,45 t_w$, where t_w is the web stiffener thickness, - weld around the stiffener's toes, - fair shape of fillet at toes in longitudinal direction. 		

AUXILIARY (CARGO TANK REGIONS)

AREA 2: Inner side and longitudinal bulkheads above 0,5H	Connection of inner side or bulkhead longitudinal ordinary stiffeners with stiffeners of transverse primary supporting members - One radiused bracket	Sheet 2.11
---	--	-------------------

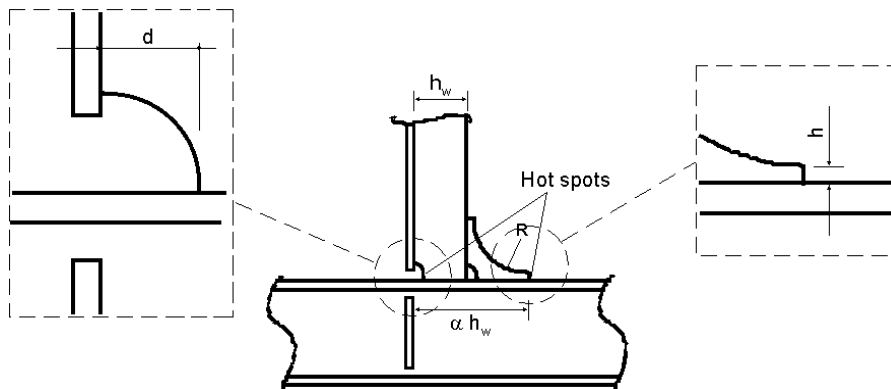

t = minimum thickness among those of the connected elements

SCANTLINGS:

- $\alpha \geq 2$
- Bracket to be symmetric.
- $R \geq 1,5 (\alpha - 1) h_w$
- h as necessary to allow the required fillet throat size, but ≤ 15 mm.
- d to be as small as possible, maximum 35 mm recommended.
- Thickness of the bracket to be not less than that of web stiffener.

FATIGUE:

Fatigue check to be carried out for $L \geq 90$ m:

- with non-watertight collar plate:
 - for $2 \leq \alpha < 2,5$ $K_b = 1,20$
 $K_\ell = 1,40$
 - for $\alpha \geq 2,5$ $K_b = 1,15$
 $K_\ell = 1,40$
- with full collar plate (watertight):
 - for $2 \leq \alpha < 2,5$ $K_b = 1,15$
 $K_\ell = 1,32$
 - for $\alpha \geq 2,5$ $K_b = 1,10$
 $K_\ell = 1,32$

CONSTRUCTION:

Misalignment (measured between the outer edges) between longitudinal, web stiffener and bracket to be in general equal to or less than $0,7 t$. For bulbs, a misalignment equal to $0,8 t$ may generally be accepted.

NDE:

Visual examination 100%.

WELDING AND MATERIALS:

Welding requirements:

- continuous fillet welding,
- throat thickness = $0,45 t_w$, where t_w is the web stiffener thickness,
- weld around the stiffener's toes,
- fair shape of fillet at toes in longitudinal direction.

AUXILIARY (CARGO TANK REGIONS)

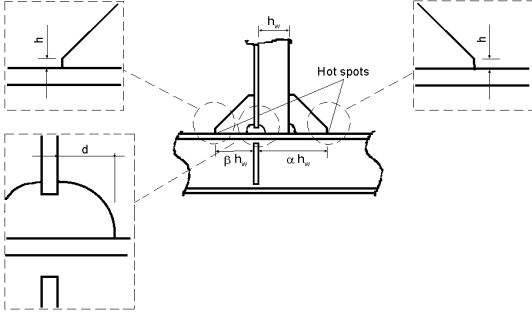
AREA 2: Inner side and longitudinal bulkheads above 0,5H	Connection of inner side or bulkhead longitudinal ordinary stiffeners with stiffeners of transverse primary supporting members - Two brackets	Sheet 2.12
 <p style="text-align: center;">t = minimum thickness among those of the connected elements</p>		
<p>SCANTLINGS:</p> <ul style="list-style-type: none"> • $\alpha \geq 2$. • $\beta \geq 1$. • Brackets to be symmetric. • h as necessary to allow the required fillet throat size, but ≤ 15 mm. • d to be as small as possible, maximum 35 mm recommended. • Thickness of the brackets to be not less than that of web stiffener. 	<p>FATIGUE:</p> <p>Fatigue check to be carried out for $L \geq 90$ m:</p> <ul style="list-style-type: none"> • with non-watertight collar plate: <ul style="list-style-type: none"> – for $2 \leq \alpha < 2,5$ $K_h = 1,20$ $K_\ell = 1,40$ – for $\alpha \geq 2,5$ $K_h = 1,15$ $K_\ell = 1,40$ • with full collar plate (watertight): <ul style="list-style-type: none"> – for $2 \leq \alpha < 2,5$ $K_h = 1,15$ $K_\ell = 1,32$ – for $\alpha \geq 2,5$ $K_h = 1,10$ $K_\ell = 1,32$ 	
<p>CONSTRUCTION:</p> <p>Misalignment (measured between the outer edges) between longitudinal, web stiffener and bracket to be in general equal to or less than $0,7 t$. For bulbs, a misalignment equal to $0,8 t$ may generally be accepted.</p>	<p>NDE:</p> <p>Visual examination 100%.</p>	
<p>WELDING AND MATERIALS:</p> <ul style="list-style-type: none"> • Welding requirements: <ul style="list-style-type: none"> - continuous fillet welding, - throat thickness = $0,45 t_w$, where t_w is the web stiffener thickness, - weld around the stiffener's toes, - fair shape of fillet at toes in longitudinal direction. • Material requirements: <ul style="list-style-type: none"> - material of brackets to be the same of longitudinals. 		

AUXILIARY (CARGO TANK REGIONS)

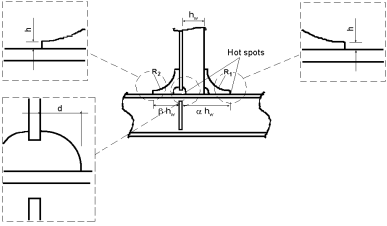
AREA 2: Inner side and longitudinal bulkheads above 0,5H	Connection of inner side or bulkhead longitudinal ordinary stiffeners with stiffeners of transverse primary supporting members - Two radiused brackets	Sheet 2.13
 <p style="text-align: center;">t = minimum thickness among those of the connected elements</p>		
SCANTLINGS: <ul style="list-style-type: none"> • $\alpha \geq 2$. • $\beta \geq 1$. • Brackets to be symmetric. • $R_1 \geq 1,5 (\alpha - 1) h_w$ • $R_2 \geq 1,5 \beta h_w$ • h as necessary to allow the required fillet throat size, but ≤ 15 mm. • d to be as small as possible, maximum 35 mm recommended. • Thickness of the brackets to be not less than that of web stiffener. 		FATIGUE: <p>Fatigue check to be carried out for $L \geq 90$ m:</p> <ul style="list-style-type: none"> • with non-watertight collar plate: <ul style="list-style-type: none"> – for $2 \leq \alpha < 2,5$ $K_h = 1,20$ <li style="text-align: right;">$K_\ell = 1,40$ – for $\alpha \geq 2,5$ $K_h = 1,15$ <li style="text-align: right;">$K_\ell = 1,40$ • with full collar plate (watertight): <ul style="list-style-type: none"> – for $2 \leq \alpha < 2,5$ $K_h = 1,15$ <li style="text-align: right;">$K_\ell = 1,32$ – for $\alpha \geq 2,5$ $K_h = 1,10$ <li style="text-align: right;">$K_\ell = 1,32$
CONSTRUCTION: <p>Misalignment (measured between the outer edges) between longitudinal, web stiffener and bracket to be in general equal to or less than $0,7 t$. For bulbs, a misalignment equal to $0,8 t$ may generally be accepted.</p>		NDE: <p>Visual examination 100%.</p>
WELDING AND MATERIALS: <ul style="list-style-type: none"> • Welding requirements: <ul style="list-style-type: none"> - continuous fillet welding, - throat thickness = $0,45 t_w$, where t_w is the web stiffener thickness, - weld around the stiffener's toes, - fair shape of fillet at toes in longitudinal direction. • Material requirements: <ul style="list-style-type: none"> - material of brackets to be the same of longitudinals. 		

AUXILIARY (CARGO TANK REGIONS)

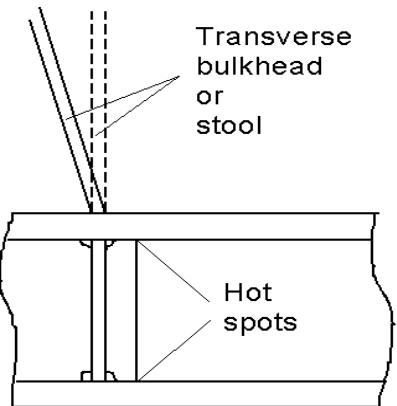
AREA 3: Double bottom in way of transverse bulkheads	Connection of bottom and inner bottom longitudinal ordinary stiffeners with floors - No bracket	Sheet 3.1
 <p>Transverse bulkhead or stool</p> <p>Hot spots</p> <p>$t =$ minimum thickness between those of:</p> <ul style="list-style-type: none"> - web of bottom or inner bottom longitudinal, - floor stiffener. 		
SCANTLINGS:	FATIGUE:	
	Fatigue check to be carried out for $L \geq 90$ m: $K_n = 1,3$ $K_t = 1,65$	
CONSTRUCTION:	NDE:	
Misalignment (measured between the outer edges) between webs of bottom and inner bottom longitudinals with floor stiffener to be in general equal to or less than $0,7 t$. For bulbs, a misalignment equal to $0,8 t$ may generally be accepted.	Visual examination 100%.	
WELDING AND MATERIALS:		
Welding requirements: <ul style="list-style-type: none"> - floor stiffeners to be connected with continuous fillet welding to bottom and inner bottom longitudinals, - throat thickness = $0,45 t_w$, where t_w is the floor stiffener thickness, - weld all around the stiffeners, - fair shape of fillet at toes in longitudinal direction. 		

AUXILIARY (CARGO TANK REGIONS)

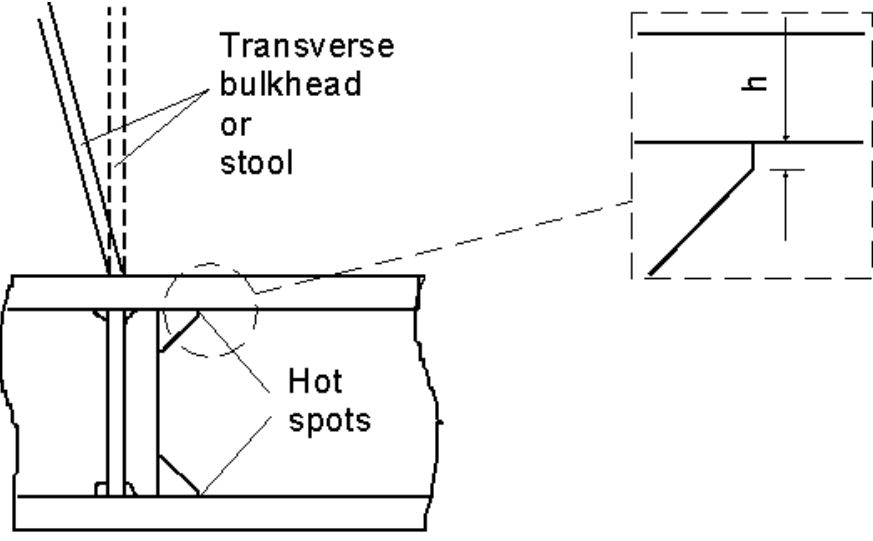
AREA 3: Double bottom in way of transverse bulkheads	Connection of bottom and inner bottom longitudinal ordinary stiffeners with floors - Brackets	Sheet 3.2
 <p style="text-align: center;">t = minimum thickness among those of the connected elements</p>		
SCANTLINGS:	FATIGUE:	
h as necessary to allow the required fillet throat size, but ≤ 15 mm.	Fatigue check to be carried out for $L \geq 90$ m: $K_h = 1,30$ $K_r = 1,55$	
CONSTRUCTION:	NDE:	
Misalignment (measured between the outer edges) between webs of bottom and inner bottom longitudinals with floor stiffener to be in general equal to or less than $0,7 t$. For bulbs, a misalignment equal to $0,8 t$ may generally be accepted.	Visual examination 100%.	
WELDING AND MATERIALS:		
Welding requirements: <ul style="list-style-type: none"> - floor stiffeners and brackets to be connected with continuous fillet welding to bottom and inner bottom longitudinals, - throat thickness = $0,45 t_w$, where t_w is the floor stiffener or bracket thickness, as applicable, - partial penetration welding between stiffeners and brackets, - weld all around the stiffeners and brackets, - fair shape of fillet at toes in longitudinal direction. 		

AUXILIARY (CARGO TANK REGIONS)

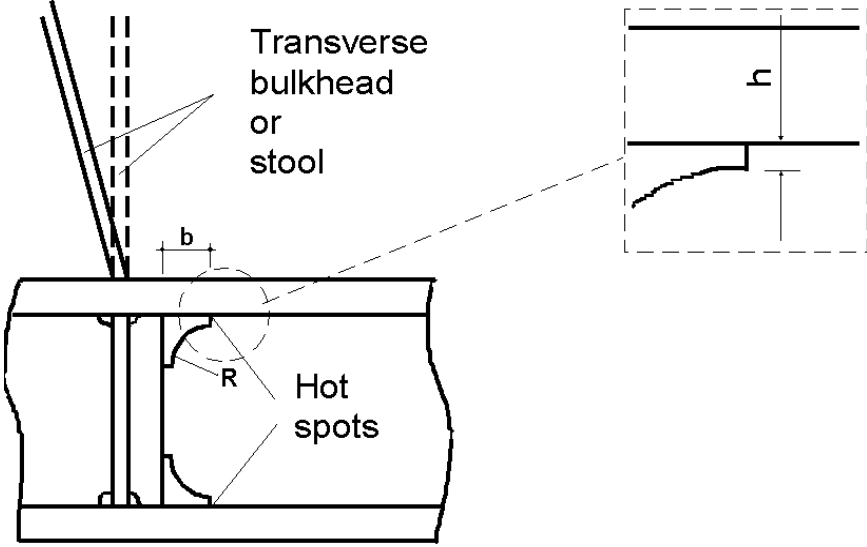
AREA 3: Double bottom in way of transverse bulkheads	Connection of bottom and inner bottom longitudinal ordinary stiffeners with floors - Radiused brackets	Sheet 3.3
 <p style="text-align: center;">t = minimum thickness among those of the connected elements</p>		
<p>SCANTLINGS:</p> <ul style="list-style-type: none"> • Brackets to be symmetric. • $R \geq 1,5 b$ • h as necessary to allow the required fillet throat size, but ≤ 15 mm. 	<p>FATIGUE:</p> <p>Fatigue check to be carried out for $L \geq 90$ m:</p> <p style="text-align: center;">$K_b = 1,25$</p> <p style="text-align: center;">$K_r = 1,5$</p>	
<p>CONSTRUCTION:</p> <p>Misalignment (measured between the outer edges) between webs of bottom and inner bottom longitudinals with floor stiffener to be in general equal to or less than $0,7 t$. For bulbs, a misalignment equal to $0,8 t$ may generally be accepted.</p>	<p>NDE:</p> <p>Visual examination 100%.</p>	
<p>WELDING AND MATERIALS:</p> <p>Welding requirements:</p> <ul style="list-style-type: none"> - floor stiffeners and brackets to be connected with continuous fillet welding to bottom and inner bottom longitudinals, - throat thickness = $0,45 t_w$, where t_w is the floor stiffener or bracket thickness, as applicable, - partial penetration welding between stiffeners and brackets, - weld all around the stiffeners and brackets, - fair shape of fillet at toes in longitudinal direction. 		

AUXILIARY (CARGO TANK REGIONS)

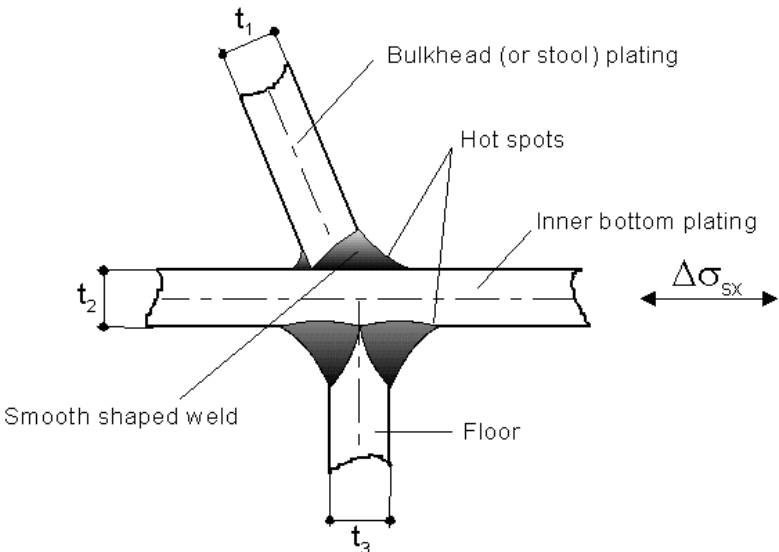
AREA 3: Double bottom in way of transverse bulkheads	Connection of inner bottom with transverse bulkheads or lower stools	Sheet 3.4
 <p data-bbox="1165 392 1348 421">Hot spot stresses:</p> $\Delta\sigma_{sx} = K_{sx} \cdot \Delta\sigma_{sx}$ $t = \min(t_1, t_2, t_3)$		
SCANTLINGS:	FATIGUE:	
	Fatigue check to be carried out for $L \geq 90$ m: $K_{sx} = 3,85$	
CONSTRUCTION:	NDE:	
<ul style="list-style-type: none"> • Misalignment (median lines) between floor and bulkhead (or stool) plating $\leq t/3$. • Cut-outs for connections of the inner bottom longitudinals to double bottom floors to be closed by collar plates welded to the inner bottom. 	The following NDE are required: <ul style="list-style-type: none"> – VE 100%, – UE 35% of full penetration weld for absence of cracks, lack of penetration and lamellar tears. 	
WELDING AND MATERIALS:		
<ul style="list-style-type: none"> • Welding requirements: <ul style="list-style-type: none"> – bulkhead (or stool) plating and supporting floors generally to be connected with full penetration welding to inner bottom plating (if not full penetration welding, the weld preparation is to be indicated on the approved drawings), – special approval of the procedure on a sample representative of the actual conditions foreseen in production, – welding sequence against the risk of lamellar tearing, – weld finishing well faired to the inner bottom plating. • Material requirements: <ul style="list-style-type: none"> – the strake of inner bottom plating in way of the connection is recommended to be of Z25/ZH25 quality. If a steel of such a quality is not adopted, 100% UE of the plate in way of the weld is required prior to and after welding. 		

AUXILIARY (CARGO TANK REGIONS)

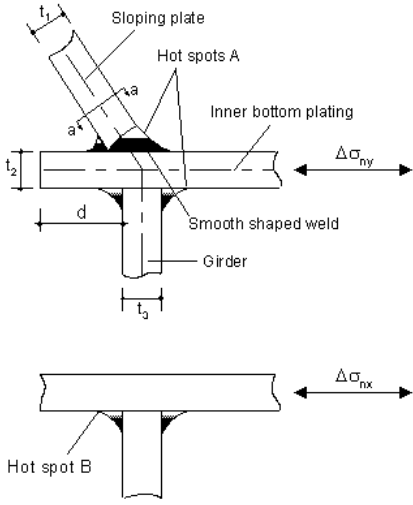
AREA 4: Double bottom in way of hopper tanks	Connection of inner bottom with hopper tank sloping plates	Sheet 4.1
<div style="display: flex; justify-content: space-between;"> <div style="width: 45%;">  <p style="text-align: center;">Section a - a</p> </div> <div style="width: 50%;"> <p>Hot spot stresses:</p> <ul style="list-style-type: none"> At hot spot A: $\Delta\sigma_{SY} = K_{SY} \cdot \Delta\sigma_{NY}$ At hot spot B: $\Delta\sigma_{SX} = K_{SX} \cdot \Delta\sigma_{NX} + K_{SYX} \cdot \Delta\sigma_{NY}$ <p>$t_A = \min(t_1, t_2, t_3),$</p> <p>$t_B = \text{minimum among:}$</p> <ul style="list-style-type: none"> – floor thickness, – hopper transverse web thickness, – $t_3.$ </div> </div>		
SCANTLINGS:	FATIGUE:	
$d \geq 50 \text{ mm.}$	Fatigue check to be carried out for $L \geq 90 \text{ m:}$ <ul style="list-style-type: none"> – $K_{SY} = 3,85$ where closed scallops $5,40$ where open scallops – $K_{SX} = 1,30$ – $K_{SYX} = 2,00$ 	
CONSTRUCTION:	NDE:	
<ul style="list-style-type: none"> • Misalignment (median lines) between girder and sloping plate $\leq t_A / 3.$ • Misalignment (median lines) between floor and hopper transverse web $\leq t_B / 3.$ 	The following NDE are required: <ul style="list-style-type: none"> – VE 100%, – UE 25% of full penetration weld for absence of cracks, lack of penetration and lamellar tears. 	
WELDING AND MATERIALS:		
<ul style="list-style-type: none"> • Welding requirements: <ul style="list-style-type: none"> – sloping plate to be connected with partial penetration welding to inner bottom plating, – approval of the procedure on a sample representative of the actual conditions foreseen in production, – welding sequence against the risk of lamellar tearing, – weld finishing well faired to the inner bottom plating on tank side. • Material requirements: <ul style="list-style-type: none"> – the strake of inner bottom plating in way of the connection is recommended to be of Z25/ZH25 quality. If a steel of such a quality is not adopted, 100% UE of the plate in way of the weld is required prior to and after welding. 		

AUXILIARY (CARGO TANK REGIONS)

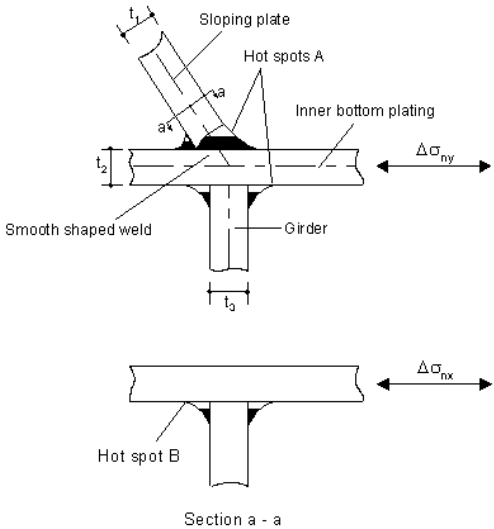
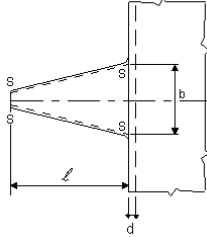
AREA 4: Double bottom in way of hopper tanks	Connection of inner bottom with hopper tank sloping plates – Prolonging brackets	Sheet 4.2
<div style="display: flex; justify-content: space-around; align-items: flex-start;"> <div style="text-align: center;">  <p>Hot spot stresses:</p> <ul style="list-style-type: none"> • At hot spot A: $\Delta\sigma_{SY} = K_{SY} \cdot \Delta\sigma_{NY}$ • At hot spot B: $\Delta\sigma_{SX} = K_{SX} \cdot \Delta\sigma_{NX} + K_{SYX} \cdot \Delta\sigma_{NY}$ <p>$t_A = \min(t_1, t_2, t_3)$,</p> <p>$t_B = \text{minimum among:}$</p> <ul style="list-style-type: none"> – floor thickness, – hopper transverse web thickness, – t_3. </div> <div style="text-align: center;">  </div> </div>		
SCANTLINGS:	FATIGUE:	
<ul style="list-style-type: none"> • Inner bottom plating to be prolonged within the hopper tank structure by brackets as shown in the sketch. • $d \geq 50$ mm. • Guidance values, to be confirmed by calculations carried out according to Ch 7, Sec 3: <ul style="list-style-type: none"> – thickness of the above brackets $\geq t_2$, – $b \geq 0,4$ times the floor spacing, – $l \geq 1,5b$. 	Fatigue check to be carried out for $L \geq 90$ m: <ul style="list-style-type: none"> – $K_{SY} = 2,40$ where closed scallops <li style="padding-left: 20px;">$3,40$ where open scallops – $K_{SX} = 1,30$ – $K_{SYX} = 1,50$ 	
CONSTRUCTION:	NDE:	
<ul style="list-style-type: none"> • Misalignment (median lines) between girder and sloping plate $\leq t_A / 3$. • Misalignment (median lines) between floor and hopper transverse web $\leq t_B / 3$. 	The following NDE are required: <ul style="list-style-type: none"> – VE 100%, – UE 25% of full penetration weld for absence of cracks, lack of penetration and lamellar tears. 	
WELDING AND MATERIALS:		
<ul style="list-style-type: none"> • Welding requirement: <ul style="list-style-type: none"> – sloping plate to be connected with partial penetration welding to inner bottom plating, – brackets to be connected with full penetration welding to inner bottom plating, – approval of the procedure on a sample representative of the actual conditions foreseen in production, – welding sequence against the risk of lamellar tearing, – weld finishing well faired to the inner bottom plating on tank side. • Material requirement: <ul style="list-style-type: none"> – the strake of inner bottom plating in way of the connection is recommended to be of Z25/ZH25 quality. If a steel of such a quality is not adopted, 100% UE of the plate in way of the weld is required prior to and after welding, – material properties of prolonging brackets to be not less than those of the inner bottom plating. 		

AUXILIARY (CARGO TANK REGIONS)

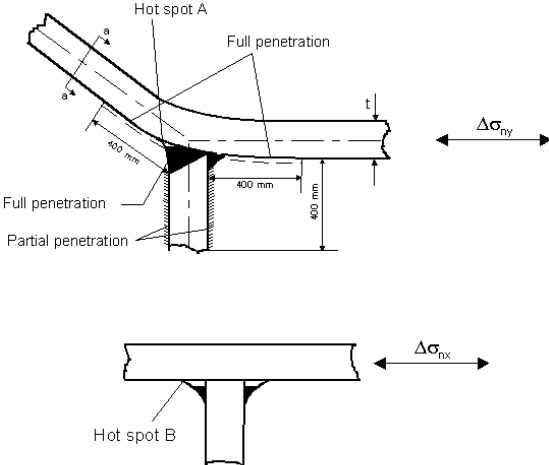
AREA 4: Double bottom in way of hopper tanks	Connection of inner bottom with hopper tank sloping plates – Radiused construction	Sheet 4.3
<div style="display: flex; justify-content: space-between;"> <div style="width: 45%;">  <p style="text-align: center;">Section a - a</p> </div> <div style="width: 50%;"> <p>Hot spot stresses:</p> <ul style="list-style-type: none"> At hot spot A: $\Delta\sigma_{SY} = K_{SY} \cdot \Delta\sigma_{ny}$ At hot spot B: $\Delta\sigma_{SX} = K_{SX} \cdot \Delta\sigma_{nx} + K_{SYX} \cdot \Delta\sigma_{ny}$ <p>t_A = minimum thickness between those of the girder and sloping plate,</p> <p>t_B = minimum among:</p> <ul style="list-style-type: none"> – floor thickness, – hopper transverse web thickness, – girder thickness. </div> </div>		
<p>SCANTLINGS:</p> <ul style="list-style-type: none"> • Inner radius of the bent plate to be between 3,5 and 5 times the thickness of the bent plate and to be indicated in the approved plan. • Transverse brackets extended to the closest longitudinals to be fitted on each side of the girder, at mid-span between floors. • Thickness of these brackets, in mm $\geq 9 + 0,03 L_1 \sqrt{k}$. 		<p>FATIGUE:</p> <p><i>Fatigue check to be carried out for $L \geq 90$ m:</i></p> <ul style="list-style-type: none"> – $K_{SY} = 3,15$ – $K_{SX} = 1,30$ – $K_{SYX} = 2,05$
<p>CONSTRUCTION:</p> <ul style="list-style-type: none"> • Misalignment (median lines) between girder and sloping plate $\leq t_A / 3$. • Misalignment (median lines) between floor and hopper transverse web $\leq t_B / 3$. • In floor or transverse webs, in way of the bent area, scallops to be avoided or closed by collar plates. 		<p>NDE:</p> <p><i>The following NDE are required:</i></p> <ul style="list-style-type: none"> – VE 100%, – UE 25% of full penetration weld for absence of cracks, lack of penetration and lamellar tears.
<p>WELDING AND MATERIALS:</p> <ul style="list-style-type: none"> • Welding requirements: <ul style="list-style-type: none"> – floors to be connected (see sketches): <ul style="list-style-type: none"> ▪ with full penetration welding to the inner bottom for a length ≥ 400 mm, ▪ with partial penetration welding to the girder for a length ≥ 400 mm, ▪ with continuous fillet welding in the remaining areas, – approval of the procedure on a sample representative of the actual conditions foreseen in production, – welding sequence against the risk of lamellar tearing, – welding procedures of longitudinal girder to the bent plate to be submitted to the Society for review, with evidence given that there is no risk of ageing after welding, – weld finishing of butt welds well faired to the inner bottom plating on ballast tank, – fair shape of fillet at hot spots. • Material requirements: <ul style="list-style-type: none"> – the radiused construction may be accepted provided that the folding procedure is submitted to the Society for review, with evidence given that the mechanical properties and, in particular, the impact properties are not deteriorated by the folding operation. 		

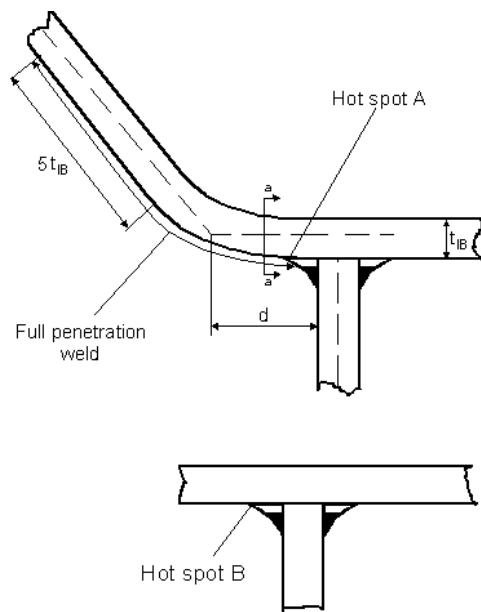
AUXILIARY (CARGO TANK REGIONS)**AREA 4: Double bottom in way of hopper tanks****Connection of inner bottom with hopper tank sloping plates – Radiused onstruction****Sheet 4.4**

Section a - a

Hot spot stresses:

- At hot spot A:

$$\Delta\sigma_{SY} = K_{SY} \cdot \Delta\sigma_{ny}$$

- At hot spot B:

$$\Delta\sigma_{SX} = K_{SX} \cdot \Delta\sigma_{nx} + K_{SYX} \cdot \Delta\sigma_{ny}$$

t = minimum among:

- floor thickness,
- hopper transverse web thickness,
- girder thickness,

 t_{IB} = inner bottom plating.**SCANTLINGS:**

- Inner radius of the bent plate to be between 3,5 and 5 times the thickness of the bent plate and to be indicated in the approved plan.
- $d \leq 40$ mm.
- Transverse brackets extended to the closest longitudinals to be fitted on each side of the girder, at mid-span between floors.
- Thickness of these brackets, in mm $\geq 9 + 0,03 L_i \sqrt{k}$.

FATIGUE:Fatigue check to be carried out for $L \geq 90$ m

- $K_{SY} = 3,85$
- $K_{SX} = 1,30$
- $K_{SYX} = 4,50$

CONSTRUCTION:

- Misalignment (median lines) between floor and hopper transverse web $\leq t / 3$.
- In floor or transverse webs, in way of the bent area, scallops to be avoided or closed by collar plates..

NDE:

Visual examination 100%.

WELDING AND MATERIALS:

- Welding requirements:
 - floors to be connected with full penetration welding to the inner bottom plating for a length $\geq 5t_{IB}$,
 - where girder is welded within the bent area, welding procedures to be submitted to the Society for review.
- Material requirements:
 - where girder is welded within the bent area, folding procedure to be submitted to the Society for review, with evidence given that the mechanical properties and, in particular, the impact properties are not deteriorated by the folding operation.

AUXILIARY (CARGO TANK REGIONS)

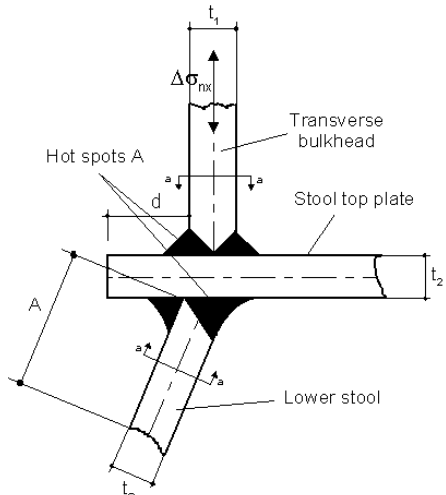
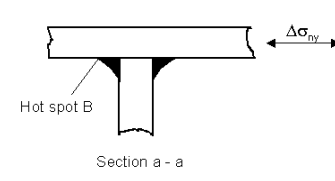
AREA 5: Lower part of transverse bulkheads with lower stools	Connection of lower stools with plane bulkheads	Sheet 5.1
<div style="display: flex; justify-content: space-between;"> <div style="width: 45%;">  </div> <div style="width: 45%;">  <p style="text-align: center;">Section a - a</p> <p>A = distance to be taken not less than the spacing of bulkhead vertical webs</p> <p>Hot spot stresses:</p> <ul style="list-style-type: none"> • At hot spot A: $\Delta\sigma_{sx} = K_{sx} \cdot \Delta\sigma_{nx}$ • At hot spot B: $\Delta\sigma_{sy} = K_{sy} \cdot \Delta\sigma_{ny} + K_{sxy} \cdot \Delta\sigma_{nx}$ <p>$t_A = \min(t_1, t_2, t_3)$</p> <p>$t_B =$ minimum among:</p> <ul style="list-style-type: none"> – thickness of member above stool top plate, – thickness of member below stool top plate, – t_2. </div> </div>		
<p>SCANTLINGS:</p> <ul style="list-style-type: none"> • $d \geq t_1$. • $t_2 \geq t_1$. • $t_3 \geq t_1$ in portion A. • Thickness of members above and below stool top plate to be not less than that of bulkhead vertical webs. 	<p>FATIGUE:</p> <p>Fatigue check to be carried out for $L \geq 90$ m:</p> <ul style="list-style-type: none"> – $K_{sx} = 3,85$ – $K_{sy} = 1,30$ – $K_{sxy} = 2,00$ 	
<p>CONSTRUCTION:</p> <ul style="list-style-type: none"> • Misalignment (median lines) between bulkhead plating and stool side plating $\leq t_x / 3$. • Misalignment (median lines) between members above and below stool top plate $\leq t_b / 3$. 	<p>NDE:</p> <p>The following NDE are required:</p> <ul style="list-style-type: none"> – VE 100%, – UE 35% of full penetration welds for absence of cracks, lack of penetration and lamellar tears. 	
<p>WELDING AND MATERIALS:</p> <ul style="list-style-type: none"> • Welding requirements: <ul style="list-style-type: none"> – bulkhead and stool side plating generally to be connected with full penetration welding to stool top plate (if not full penetration welding, the weld preparation is to be indicated on the approved drawings), – approval of the procedure on a sample representative of the actual conditions foreseen in production, – welding sequence against the risk of lamellar tearing is recommended in case Z material is not adopted for the stool top plate, – weld finishing well faired to the stool top plate. • Material requirements: <ul style="list-style-type: none"> – the stool top plate is recommended to be Z25/ZH25 quality. If a steel of such a quality is not adopted, 100% UE of the plate in way of the weld is required prior to and after welding, – material properties of: <ul style="list-style-type: none"> ▪ the stool top plate, ▪ the portion A of the stool side plating, <p>to be not less than those of the transverse bulkhead plating.</p> 		

AUXILIARY (CARGO TANK REGIONS)

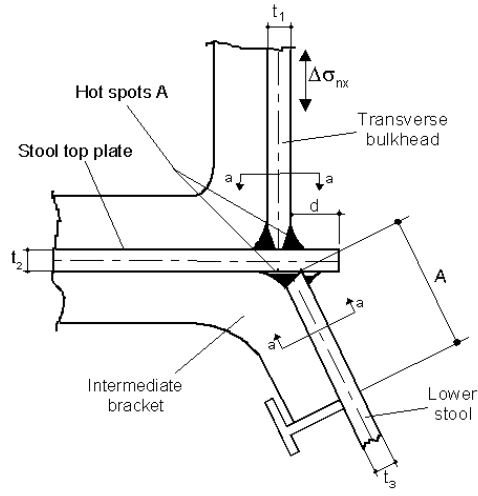
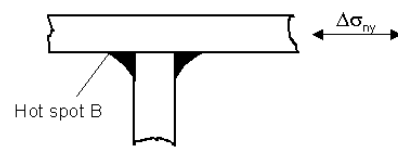
AREA 5: Lower part of transverse bulkheads with lower stools	Connection of lower stools with plane bulkheads in way of intermediate brackets	Sheet 5.2
<div style="display: flex; justify-content: space-between;"> <div style="width: 45%;">  </div> <div style="width: 45%;">  <p style="text-align: center;">Section a - a</p> </div> </div> <p style="margin-top: 10px;">A = distance to be taken not less than the spacing of bulkhead vertical webs</p> <p>Hot spot stresses:</p> <ul style="list-style-type: none"> • At hot spot A: $\Delta\sigma_{SX} = K_{SX} \cdot \Delta\sigma_{nx}$ • At hot spot B: $\Delta\sigma_{SY} = K_{SY} \cdot \Delta\sigma_{ny} + K_{SXY} \cdot \Delta\sigma_{nx}$ <p>$t_A = \min(t_1, t_2, t_3)$</p> <p>$t_B = \text{minimum among:}$</p> <ul style="list-style-type: none"> – thickness of member above stool top plate, – thickness of intermediate bracket, – t_2. 		
<p>SCANTLINGS:</p> <ul style="list-style-type: none"> • $d \geq t_1$, • $t_2 \geq t_1$, • $t_3 \geq t_1$ in portion A. • Thickness of intermediate brackets and members above stool top plate to be not less than that of bulkhead vertical webs. 	<p>FATIGUE:</p> <p>Fatigue check to be carried out for $L \geq 90$ m:</p> <ul style="list-style-type: none"> – $K_{SX} = 3,55$ – $K_{SY} = 1,30$ – $K_{SXY} = 1,75$ 	
<p>CONSTRUCTION:</p> <ul style="list-style-type: none"> • Misalignment (median lines) between bulkhead plating and stool side plating $\leq t_A / 3$. • Misalignment (median lines) between intermediate bracket and member above stool top plate $\leq t_B / 3$. • Intermediate brackets to be fitted in place and welded after the welding of the joint between the stool side plating and the stool top plate. 	<p>NDE:</p> <p>The following NDE are required:</p> <ul style="list-style-type: none"> – VE 100%, – UE 35% of full penetration welds for absence of cracks, lack of penetration and lamellar tears. 	
<p>WELDING AND MATERIALS:</p> <ul style="list-style-type: none"> • Welding requirements: <ul style="list-style-type: none"> – bulkhead and stool side plating generally to be connected with full penetration welding to stool top plate (if not full penetration welding, the weld preparation is to be indicated on the approved drawings), – brackets to be connected with continuous fillet welding to plating and stiffeners, – approval of the procedure on a sample representative of the actual conditions foreseen in production, – welding sequence against the risk of lamellar tearing is recommended in case Z material is not adopted for the stool top plate, – weld finishing well faired to the stool top plate. • Material requirements: <ul style="list-style-type: none"> – the stool top plate is recommended to be Z25/ZH25 quality. If a steel of such a quality is not adopted, 100% UE of the plate in way of the weld is required prior to and after welding, – material properties of: <ul style="list-style-type: none"> ▪ the stool top plate, ▪ the portion A of the stool side plating, <p style="margin-left: 40px;">to be not less than those of the transverse bulkhead plating.</p>		

AUXILIARY (CARGO TANK REGIONS)

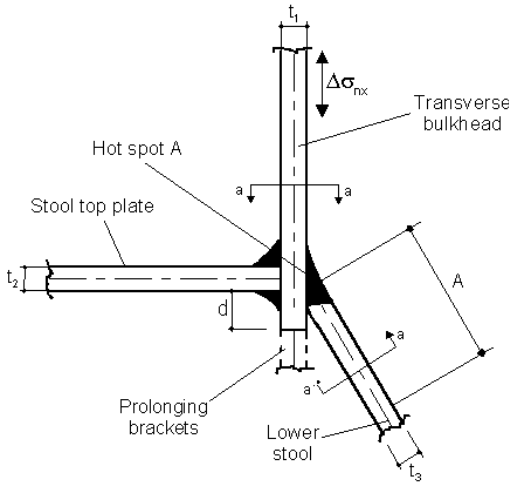
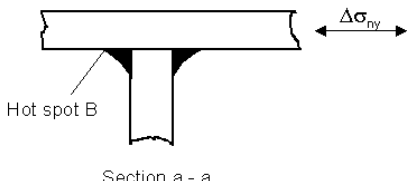
AREA 5: Lower part of transverse bulkheads with lower stools	Connection of lower stools with plane bulkheads – Prolonging brackets	Sheet 5.3
<div style="display: flex; justify-content: space-between;"> <div style="width: 45%;">  </div> <div style="width: 45%;">  <p style="text-align: center;">Section a - a</p> <p>A = distance to be taken not less than the spacing of bulkhead vertical webs</p> <p>Hot spot stresses:</p> <ul style="list-style-type: none"> • At hot spot A: $\Delta\sigma_{SX} = K_{SX} \cdot \Delta\sigma_{nx}$ • At hot spot B: $\Delta\sigma_{SY} = K_{SY} \cdot \Delta\sigma_{ny} + K_{SXY} \cdot \Delta\sigma_{nx}$ <p>$t_A = \min(t_1, t_2, t_3)$</p> <p>$t_B =$ minimum among:</p> <ul style="list-style-type: none"> – thickness of member above stool top plate, – thickness of member below stool top plate, – t_2. </div> </div>		
<p>SCANTLINGS:</p> <ul style="list-style-type: none"> • $d \geq 50$ mm. • $t_2 \geq t_1$. • $t_3 \geq t_1$ in portion A. • Thickness of prolonging brackets $\geq t_1$. • Thickness of members above and below stool top plate to be not less than that of bulkhead vertical webs. 	<p>FATIGUE:</p> <p>Fatigue check to be carried out for $L \geq 90$ m:</p> <ul style="list-style-type: none"> – $K_{SX} = 2,40$ – $K_{SY} = 1,30$ – $K_{SXY} = 1,5$ 	
<p>CONSTRUCTION:</p> <ul style="list-style-type: none"> • Misalignment (median lines) between stool top plate and stool side plating $\leq t_A / 3$. • Misalignment (median lines) between members above and below stool top plate $\leq t_B / 3$. 	<p>NDE:</p> <p>The following NDE are required:</p> <ul style="list-style-type: none"> – VE 100%, – UE 35% of full penetration welds for absence of cracks, lack of penetration and lamellar tears. 	
<p>WELDING AND MATERIALS:</p> <ul style="list-style-type: none"> • Welding requirements: <ul style="list-style-type: none"> – stool side plating to be connected with full penetration welding to the bulkhead plating. Root gap to be checked along the production steps as appropriate, – brackets to be connected with full penetration welding to transverse bulkhead plating, – full penetration weld of stool side plating to bulkhead plating to be welded first, – welding sequence against lamellar tearing in the bulkhead plating is recommended. • Material requirements: <ul style="list-style-type: none"> – the lower strake of transverse bulkhead plating is recommended to be Z25/ZH25 quality. If a steel of such a quality is not adopted, 100% UE of the strake in way of the weld is required prior to and after welding, – material properties of: <ul style="list-style-type: none"> ▪ the stool top plate, ▪ the portion A of the stool side plating, <p>to be not less than those of the transverse bulkhead plating,</p> <p>– material properties of prolonging brackets to be not less than those of the bulkhead plating.</p>		

AUXILIARY (CARGO TANK REGIONS)

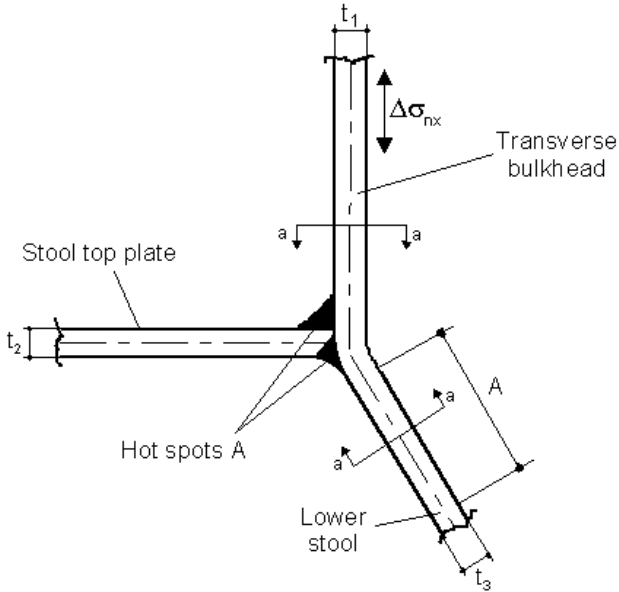
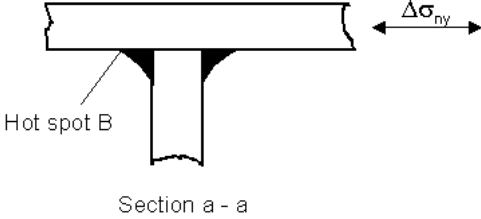
AREA 5: Lower part of transverse bulkheads with lower stools	Connection of lower stools with plane bulkheads – Radiused construction	Sheet 5.4
<div style="display: flex; justify-content: space-between;"> <div style="width: 45%;">  </div> <div style="width: 45%;">  <p style="text-align: center;">Section a - a</p> <p>A = distance to be taken not less than the spacing of bulkhead vertical webs</p> <p>Hot spot stresses:</p> <ul style="list-style-type: none"> • At hot spot A: $\Delta\sigma_{SX} = K_{SX} \cdot \Delta\sigma_{nx}$ • At hot spot B: $\Delta\sigma_{SY} = K_{SY} \cdot \Delta\sigma_{ny} + K_{SXY} \cdot \Delta\sigma_{nx}$ <p>$t_A = \min(t_1, t_2, t_3)$</p> <p>$t_B =$ minimum among:</p> <ul style="list-style-type: none"> - thickness of member above stool top plate, - thickness of member below stool top plate, - t_2. </div> </div>		
<p>SCANTLINGS:</p> <ul style="list-style-type: none"> • Inner radius of the bent plate to be between 3,5 and 5 times the thickness of the bent plate and to be indicated in the approved plan. • $t_2 \geq t_1$. • $t_3 \geq t_1$ in portion A. • Thickness of members above and below stool top plate to be not less than that of bulkhead vertical webs. 	<p>FATIGUE:</p> <p>Fatigue check to be carried out for $L \geq 90$ m:</p> <ul style="list-style-type: none"> - $K_{SX} = 3,30$ - $K_{SY} = 1,30$ - $K_{SXY} = 2,25$ 	
<p>CONSTRUCTION:</p> <ul style="list-style-type: none"> • Misalignment (median lines) between stool top plate and stool side plating $\leq t_A / 3$. • Misalignment (median lines) between members above and below stool top plate $\leq t_B / 3$. • If not full penetration welding of stool top plate to bulkhead, the weld preparation is to be indicated on the approved drawings. • Butt welds between transverse bulkhead and stool side plating at a distance greater than 500 mm from the stool top plate. 	<p>NDE:</p> <p>The following NDE are required:</p> <ul style="list-style-type: none"> - VE 100%, - UE 35% of full penetration welds, if any, for absence of cracks, lack of penetration and lamellar tears. 	
<p>WELDING AND MATERIALS:</p> <ul style="list-style-type: none"> • Welding requirements: <ul style="list-style-type: none"> -welding sequence against the risk of lamellar tearing in the bulkhead plate is recommended, -weld finishing well faired to the bulkhead plating and stool side plating. • Material requirements: <ul style="list-style-type: none"> - the radiused construction may be accepted provided that the folding procedure is submitted to the Society for review, with evidence given that the mechanical properties and, in particular, the impact properties are not deteriorated by the folding operation. - material properties of: <ul style="list-style-type: none"> ▪the stool top plate, ▪the portion A of the stool side plating, <p style="margin-left: 40px;">to be not less than those of the transverse bulkhead plating.</p>		

AUXILIARY (CARGO TANK REGIONS)

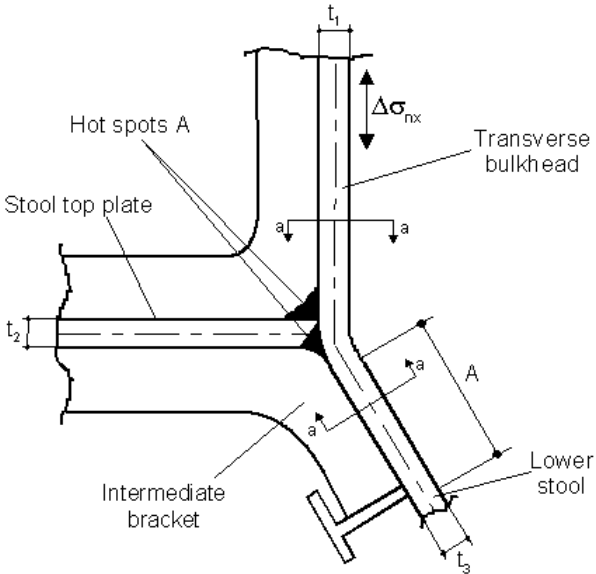
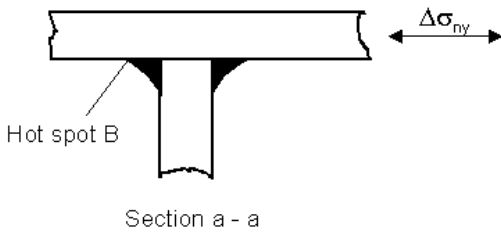
AREA 5: Lower part of transverse bulkheads with lower stools	Connection of lower stools with plane bulkheads in way of intermediate brackets – Radiused construction	Sheet 5.5
<div style="display: flex; justify-content: space-between;"> <div style="width: 45%;">  </div> <div style="width: 45%;">  <p style="text-align: center;">Section a - a</p> <p>A = distance to be taken not less than the spacing of bulkhead vertical webs</p> <p>Hot spot stresses:</p> <ul style="list-style-type: none"> • At hot spot A: $\Delta\sigma_{sx} = K_{sx} \cdot \Delta\sigma_{nx}$ • At hot spot B: $\Delta\sigma_{sy} = K_{sy} \cdot \Delta\sigma_{ny} + K_{sxy} \cdot \Delta\sigma_{nx}$ <p>$t_A = \min(t_1, t_2, t_3)$</p> <p>$t_B =$ minimum among:</p> <ul style="list-style-type: none"> – thickness of member above stool top plate, – thickness of intermediate bracket, – t_2. </div> </div>		
<p>SCANTLINGS:</p> <ul style="list-style-type: none"> • Inner radius of the bent plate to be between 3,5 and 5 times the thickness of the bent plate and to be indicated in the approved plan. • $t_2 \geq t_1$. • $t_3 \geq t_1$ in portion A. • Thickness of intermediate brackets and members above stool top plate to be not less than that of bulkhead vertical webs. 	<p>FATIGUE:</p> <p>Fatigue check to be carried out for $L \geq 90$ m:</p> <ul style="list-style-type: none"> – $K_{sx} = 3,15$ – $K_{sy} = 1,30$ – $K_{sxy} = 2,05$ 	
<p>CONSTRUCTION:</p> <ul style="list-style-type: none"> • Misalignment (median lines) between stool top plate and stool side plating $\leq t_A / 3$. • Misalignment (median lines) between intermediate bracket and member below stool top plate $\leq t_B / 3$. • If not full penetration welding of stool top plate to bulkhead, the weld preparation is to be indicated on the approved drawings. • Intermediate brackets to be fitted in place and welded after the welding of the joint between the stool top plate and the bulkhead plating. • Butt welds between transverse bulkhead and stool side plating at a distance greater than 500 mm from the stool top plate. 	<p>NDE:</p> <p>The following NDE are required:</p> <ul style="list-style-type: none"> – VE 100%, – UE 35% of full penetration welds, if any, for absence of cracks, lack of penetration and lamellar tears. 	
<p>WELDING AND MATERIALS:</p> <ul style="list-style-type: none"> • Welding requirements: <ul style="list-style-type: none"> – brackets to be connected with continuous fillet welding to plating and stiffeners, – welding sequence against the risk of lamellar tearing in the bulkhead plate is recommended, – weld finishing well faired to the bulkhead plating and stool side plating. • Material requirements: <ul style="list-style-type: none"> – the radiused construction may be accepted provided that the folding procedure is submitted to the Society for review, with evidence given that the mechanical properties and, in particular, the impact properties are not deteriorated by the folding operation. – material properties of: <ul style="list-style-type: none"> ▪ the stool top plate, ▪ the portion A of the stool side plating, <p>to be not less than those of the transverse bulkhead plating.</p>		

AUXILIARY (CARGO TANK REGIONS)

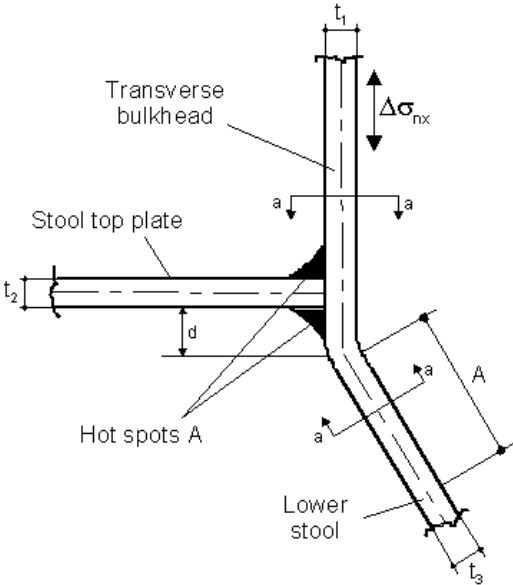
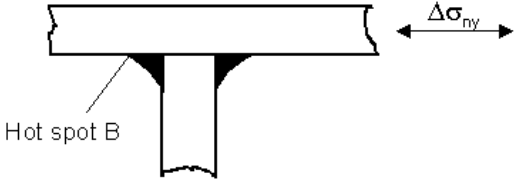
AREA 5: Lower part of transverse bulkheads with lower stools	Connection of lower stools with plane bulkheads – Radiused construction	Sheet 5.6
<div style="display: flex; justify-content: space-around;"> <div style="text-align: center;">  <p>Transverse bulkhead</p> <p>Stool top plate</p> <p>Hot spots A</p> <p>Lower stool</p> </div> <div style="text-align: center;">  <p>Hot spot B</p> <p>Section a - a</p> </div> </div> <p>A = distance to be taken not less than the spacing of bulkhead vertical webs</p> <p>Hot spot stresses:</p> <ul style="list-style-type: none"> • At hot spot A: $\Delta\sigma_{SX} = K_{SX} \cdot \Delta\sigma_{nx}$ • At hot spot B: $\Delta\sigma_{SY} = K_{SY} \cdot \Delta\sigma_{ny} + K_{SXY} \cdot \Delta\sigma_{nx}$ <p>t = minimum among:</p> <ul style="list-style-type: none"> - thickness of member above stool top plate, - thickness of member below stool top plate, - t_2. 		
<p>SCANTLINGS:</p> <ul style="list-style-type: none"> • Inner radius of the bent plate to be between 3,5 and 5 times the thickness of the bent plate and to be indicated in the approved plan. • $d \leq 40$ mm. • $t_2 \geq t_1$. • $t_3 \geq t_1$ in portion A. • Thickness of members above and below stool top plate to be not less than that of bulkhead vertical webs. 	<p>FATIGUE:</p> <p>Fatigue check to be carried out for $L \geq 90$ m:</p> <ul style="list-style-type: none"> - $K_{SX} = 4,50$ - $K_{SY} = 1,30$ - $K_{SXY} = 5,6$ 	
<p>CONSTRUCTION:</p> <ul style="list-style-type: none"> • Misalignment (median lines) between members above and below stool top plate $\leq t / 3$. • If not full penetration welding of stool top plate to bulkhead, the weld preparation is to be indicated on the approved drawings. • Butt welds between transverse bulkhead and stool side plating at a distance greater than 500 mm from the stool top plate. 	<p>NDE:</p> <p>The following NDE are required:</p> <ul style="list-style-type: none"> - VE 100%, - UE 35% of full penetration welds, if any, for absence of cracks, lack of penetration and lamellar tears. 	
<p>WELDING AND MATERIALS:</p> <p>Material requirements:</p> <ul style="list-style-type: none"> - where stool top plate is welded within the bent area, folding procedure to be submitted to the Society for review, with evidence given that the mechanical properties and, in particular, the impact properties are not deteriorated by the folding operation, - material properties of: <ul style="list-style-type: none"> ▪ the stool top plate, ▪ the portion A of the stool side plating, <p>to be not less than those of the transverse bulkhead plating.</p>		

AUXILIARY (CARGO TANK REGIONS)

<p>AREA 5: Lower part of transverse bulkheads with lower stools</p>	<p>Connection of lower stools with plane bulkheads in way of intermediate brackets - Radiused construction</p>	<p>Sheet 5.7</p>
<div style="display: flex; justify-content: space-between;"> <div style="width: 45%;"> </div> <div style="width: 45%;"> <p style="text-align: center;">Section a - a</p> <p>A = distance to be taken not less than the spacing of bulkhead vertical webs</p> <p>Hot spot stresses:</p> <ul style="list-style-type: none"> • At hot spot A: $\Delta\sigma_{SX} = K_{SX} \cdot \Delta\sigma_{nx}$ • At hot spot B: $\Delta\sigma_{SY} = K_{SY} \cdot \Delta\sigma_{ny} + K_{SXY} \cdot \Delta\sigma_{nx}$ <p>t = minimum among:</p> <ul style="list-style-type: none"> - thickness of member above stool top plate, - thickness of intermediate bracket, - t_2. </div> </div>		
<p>SCANTLINGS:</p> <ul style="list-style-type: none"> • Inner radius of the bent plate to be between 3,5 and 5 times the thickness of the bent plate and to be indicated in the approved plan. • $d \leq 40$ mm. • $t_2 \geq t_1$. • $t_3 \geq t_1$ in portion A. • Thickness of intermediate brackets and members above stool top plate to be not less than that of bulkhead vertical webs. 		<p>FATIGUE:</p> <p>Fatigue check to be carried out for $L \geq 90$ m:</p> <ul style="list-style-type: none"> - $K_{SX} = 3,85$ - $K_{SY} = 1,30$ - $K_{SXY} = 4,50$
<p>CONSTRUCTION:</p> <ul style="list-style-type: none"> • Misalignment (median lines) between intermediate bracket and member above stool top plate $\leq t/3$. • If not full penetration welding of stool top plate to bulkhead, the weld preparation is to be indicated on the approved drawings. • Intermediate brackets to be fitted in place and welded after the welding of the joint between the stool top plate and the bulkhead plating. • Butt welds between transverse bulkhead and stool side plating at a distance greater than 500 mm from the stool top plate. 		<p>NDE:</p> <p>The following NDE are required:</p> <ul style="list-style-type: none"> - VE 100%, - UE 35% of full penetration welds, if any, for absence of cracks, lack of penetration and lamellar tears.
<p>WELDING AND MATERIALS:</p> <p>Material requirements:</p> <ul style="list-style-type: none"> - where stool top plate is welded within the bent area, folding procedure to be submitted to the Society for review, with evidence given that the mechanical properties and, in particular, the impact properties are not deteriorated by the folding operation, - material properties of: <ul style="list-style-type: none"> ▪ the stool top plate, ▪ the portion A of the stool side plating, to be not less than those of the transverse bulkhead plating. 		

AUXILIARY (CARGO TANK REGIONS)

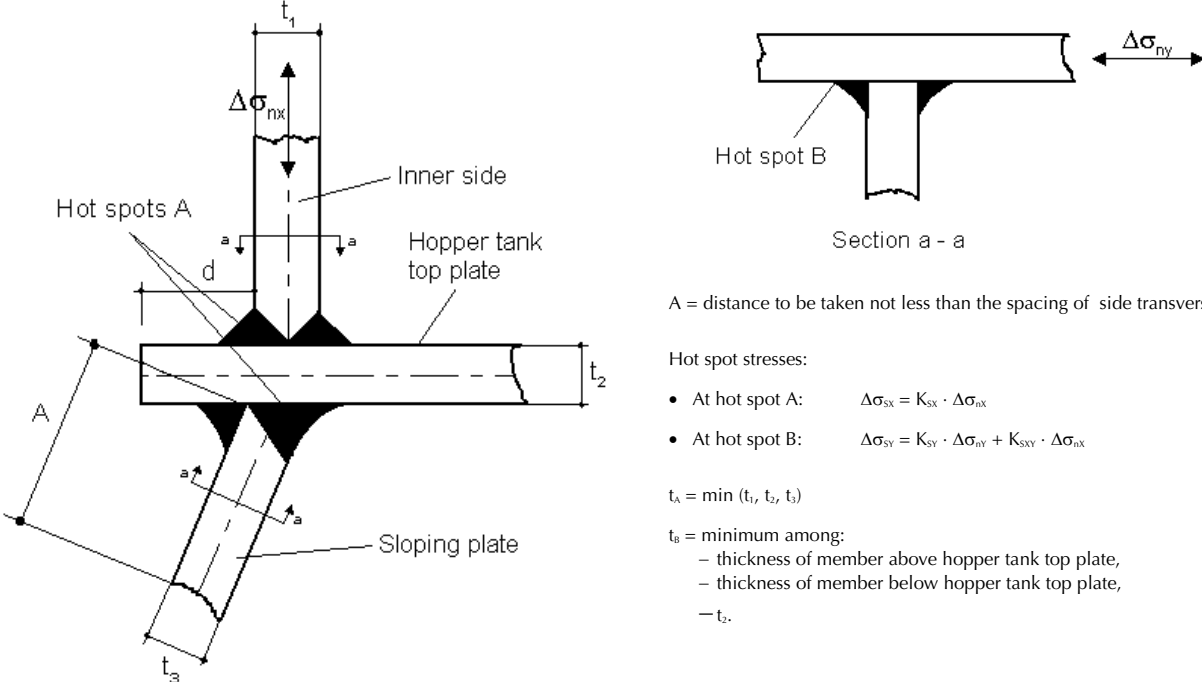
AREA 6: Lower part of inner side	Connection of hopper tank sloping plates with inner side	Sheet 6.1
 <p>Hot spot stresses:</p> <ul style="list-style-type: none"> • At hot spot A: $\Delta\sigma_{SX} = K_{SX} \cdot \Delta\sigma_{nx}$ • At hot spot B: $\Delta\sigma_{SY} = K_{SY} \cdot \Delta\sigma_{ny} + K_{SXY} \cdot \Delta\sigma_{nx}$ <p>$t_A = \min(t_1, t_2, t_3)$</p> <p>$t_b = \text{minimum among:}$</p> <ul style="list-style-type: none"> – thickness of member above hopper tank top plate, – thickness of member below hopper tank top plate, – t_2. 		
<p>SCANTLINGS:</p> <ul style="list-style-type: none"> • $d \geq t_1$. • $t_2 \geq t_1$. • $t_3 \geq t_1$ in portion A. • Thickness of members above and below hopper tank top plate to be not less than that of side transverses. 	<p>FATIGUE:</p> <p>Fatigue check to be carried out for $L \geq 90$ m:</p> <ul style="list-style-type: none"> – $K_{SX} = 3,85$ – $K_{SY} = 1,30$ – $K_{SXY} = 2,00$ 	
<p>CONSTRUCTION:</p> <ul style="list-style-type: none"> • Misalignment (median lines) between inner side plating and hopper tank sloping plate $\leq t_A / 3$. • Misalignment (median lines) between members above and below hopper tank top plate $\leq t_b / 3$. 	<p>NDE:</p> <p>The following NDE are required:</p> <ul style="list-style-type: none"> – VE 100%, – UE 25% of full penetration welds for absence of cracks, lack of penetration and lamellar tears. 	
<p>WELDING AND MATERIALS:</p> <ul style="list-style-type: none"> • Welding requirements: <ul style="list-style-type: none"> – inner side and hopper tank sloping plate generally to be connected with full penetration welding to hopper tank top plate (if not full penetration welding, the weld preparation is to be indicated on the approved drawings), – approval of the procedure on a sample representative of the actual conditions foreseen in production, – welding sequence against the risk of lamellar tearing is recommended in case Z material is not adopted for the hopper tank top plate, – weld finishing well faired to the hopper tank top plate. • Material requirements: <ul style="list-style-type: none"> – the hopper tank top plate is recommended to be Z25/ZH25 quality. If a steel of such a quality is not adopted, 100% UE of the plate in way of the weld is required prior to and after welding, – material properties of the portion A of the hopper tank sloping plate to be not less than those of the inner side plating. 		

AUXILIARY (CARGO TANK REGIONS)

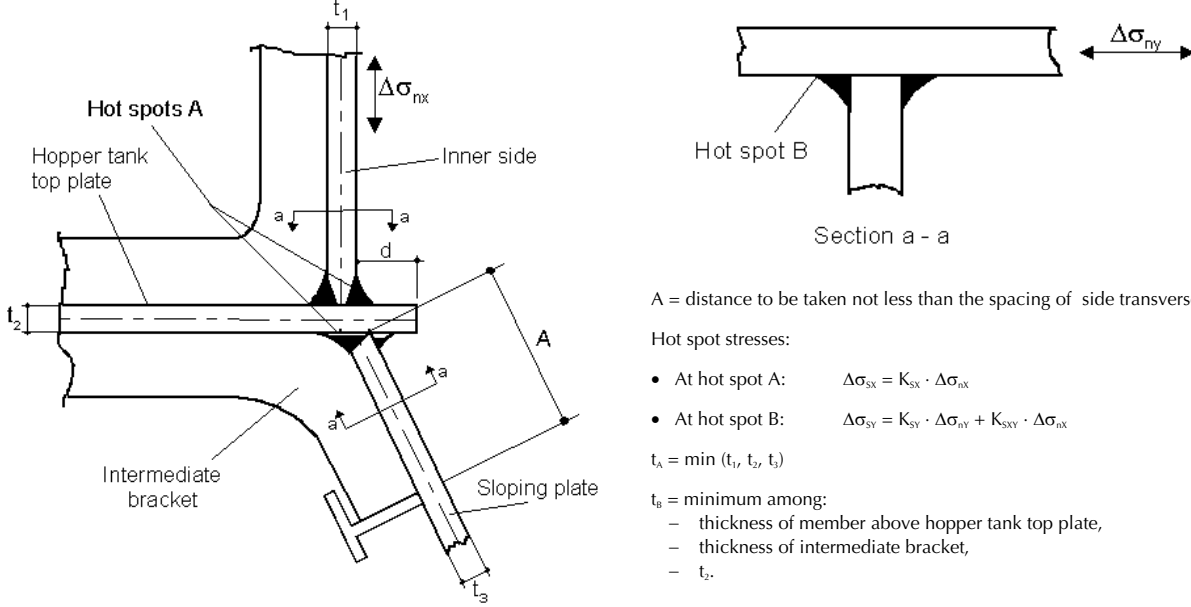
AREA 6: Lower part of inner side	Connection of hopper tank sloping plates with inner side in way of intermediate brackets	Sheet 6.2
 <p>A = distance to be taken not less than the spacing of side transverses</p> <p>Hot spot stresses:</p> <ul style="list-style-type: none"> • At hot spot A: $\Delta\sigma_{SX} = K_{SX} \cdot \Delta\sigma_{nx}$ • At hot spot B: $\Delta\sigma_{SY} = K_{SY} \cdot \Delta\sigma_{ny} + K_{SXY} \cdot \Delta\sigma_{nx}$ <p>$t_x = \min(t_1, t_2, t_3)$</p> <p>$t_0 =$ minimum among:</p> <ul style="list-style-type: none"> - thickness of member above hopper tank top plate, - thickness of intermediate bracket, - t_2. 		
<p>SCANTLINGS:</p> <ul style="list-style-type: none"> • $d \geq t_1$, • $t_2 \geq t_1$, • $t_3 \geq t_1$ in portion A. • Thickness of intermediate brackets and members above hopper tank top plate to be not less than that of side transverses. 	<p>FATIGUE:</p> <p>Fatigue check to be carried out for $L \geq 90$ m:</p> <ul style="list-style-type: none"> - $K_{SX} = 3,55$ - $K_{SY} = 1,30$ - $K_{SXY} = 1,75$ 	
<p>CONSTRUCTION:</p> <ul style="list-style-type: none"> • Misalignment (median lines) between inner side plating and hopper tank sloping plate $\leq t_x / 3$. • Misalignment (median lines) between intermediate bracket and member above hopper tank top plate $\leq t_0 / 3$. • Intermediate brackets to be fitted in place and welded after the welding of the joint between the hopper tank sloping plate and the hopper tank top plate. 	<p>NDE:</p> <p>The following NDE are required:</p> <ul style="list-style-type: none"> - VE 100%, - UE 25% of full penetration welds for absence of cracks, lack of penetration and lamellar tears. 	
<p>WELDING AND MATERIALS:</p> <ul style="list-style-type: none"> • Welding requirements: <ul style="list-style-type: none"> - inner side and hopper tank sloping plate generally to be connected with full penetration welding to hopper tank top plate (if not full penetration welding, the weld preparation is to be indicated on the approved drawings), - brackets to be connected with continuous fillet welding to plating and stiffeners, - approval of the procedure on a sample representative of the actual conditions foreseen in production, - welding sequence against the risk of lamellar tearing is recommended in case Z material is not adopted for the hopper tank top plate, - weld finishing well faired to the hopper tank top plate. • Material requirements: <ul style="list-style-type: none"> - the hopper tank top plate is recommended to be Z25/ZH25 quality. If a steel of such a quality is not adopted, 100% UE of the plate in way of the weld is required prior to and after welding, - material properties of the portion A of the hopper tank sloping plate to be not less than those of the inner side plating. 		

AUXILIARY (CARGO TANK REGIONS)

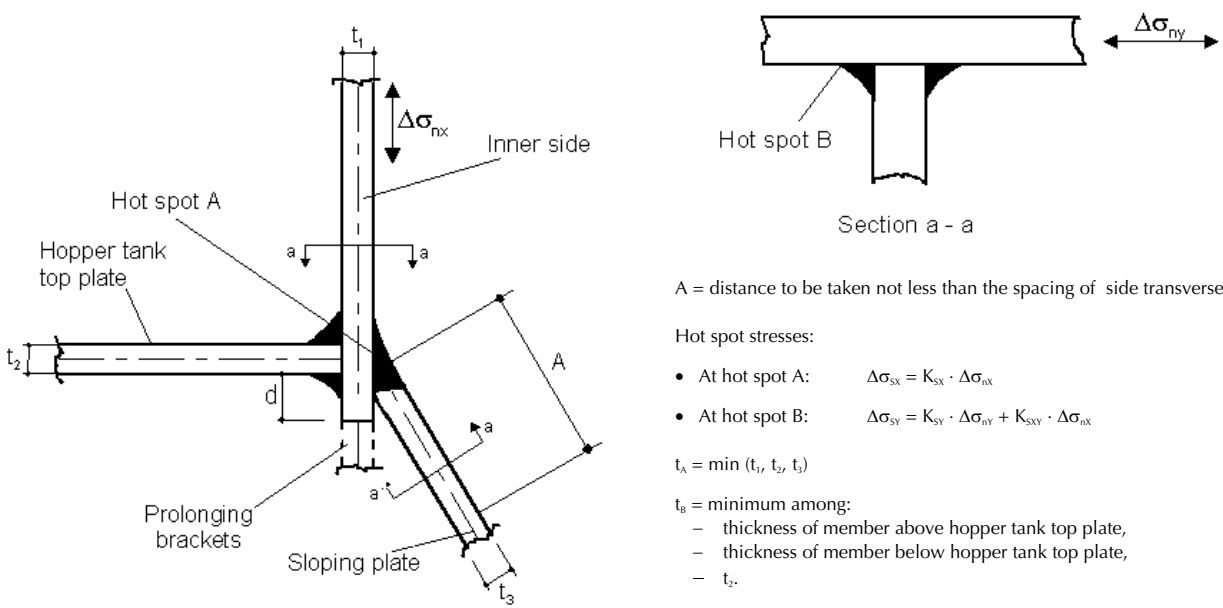
AREA 6: Lower part of inner side	Connection of hopper tank sloping plates with inner side – Prolonging brackets	Sheet 6.3
 <p>A = distance to be taken not less than the spacing of side transverses</p> <p>Hot spot stresses:</p> <ul style="list-style-type: none"> • At hot spot A: $\Delta\sigma_{sx} = K_{sx} \cdot \Delta\sigma_{ax}$ • At hot spot B: $\Delta\sigma_{sy} = K_{sy} \cdot \Delta\sigma_{ay} + K_{sxy} \cdot \Delta\sigma_{ax}$ <p>$t_A = \min(t_1, t_2, t_3)$</p> <p>$t_b =$ minimum among:</p> <ul style="list-style-type: none"> – thickness of member above hopper tank top plate, – thickness of member below hopper tank top plate, – t_2. 		
<p>SCANTLINGS:</p> <ul style="list-style-type: none"> • $d \geq 50$ mm. • $t_2 \geq t_1$. • $t_3 \geq t_1$ in portion A. • Thickness of prolonging brackets $\geq t_1$. • Thickness of members above and below hopper tank top plate to be not less than that of side transverses. 	<p>FATIGUE:</p> <p>Fatigue check to be carried out for $L \geq 90$ m:</p> <ul style="list-style-type: none"> – $K_{sx} = 2,40$ – $K_{sy} = 1,30$ – $K_{sxy} = 1,50$ 	
<p>CONSTRUCTION:</p> <ul style="list-style-type: none"> • Misalignment (median lines) between hopper tank top plate and hopper tank sloping plate $\leq t_A / 3$. • Misalignment (median lines) between members above and below hopper tank top plate $\leq t_b / 3$. 	<p>NDE:</p> <p>The following NDE are required:</p> <ul style="list-style-type: none"> – VE 100%, – UE 25% of full penetration welds for absence of cracks, lack of penetration and lamellar tears. 	
<p>WELDING AND MATERIALS:</p> <ul style="list-style-type: none"> • Welding requirements: <ul style="list-style-type: none"> – Hopper tank sloping plate to be connected with full penetration welding to the inner side plating. Root gap to be checked along the production steps as appropriate, – Prolonging brackets to be connected with full penetration welding to inner side plating, – full penetration weld of hopper tank sloping plate to inner side plating to be welded first, – welding sequence against lamellar tearing in the inner side plating is recommended. • Material requirements: <ul style="list-style-type: none"> – the lower strake of inner side plating is recommended to be Z25/ZH25 quality. If a steel of such a quality is not adopted, 100% UE of the strake in way of the weld is required prior to and after welding, – material properties of the portion A of the hopper tank sloping plate to be not less than those of the inner side plating, – material properties of prolonging brackets to be not less than those of the inner side plating. 		

AUXILIARY (CARGO TANK REGIONS)

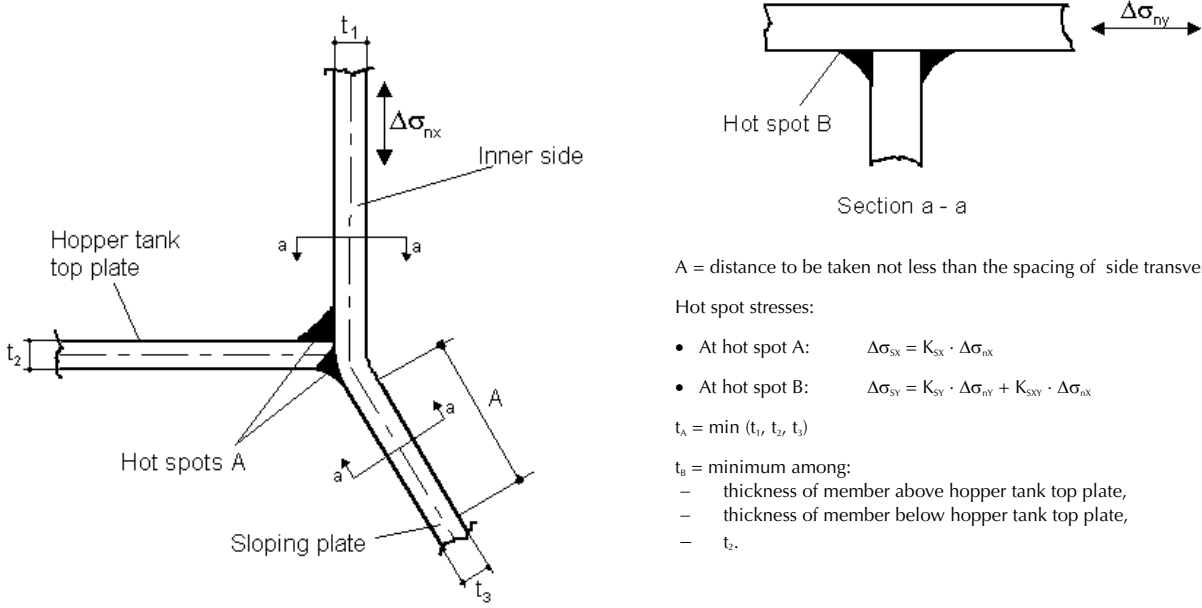
AREA 6: Lower part of inner side	Connection of hopper tank sloping plates with inner side – Radiused construction	Sheet 6.4
 <p>A = distance to be taken not less than the spacing of side transverses</p> <p>Hot spot stresses:</p> <ul style="list-style-type: none"> • At hot spot A: $\Delta\sigma_{sx} = K_{sx} \cdot \Delta\sigma_{nx}$ • At hot spot B: $\Delta\sigma_{sy} = K_{sy} \cdot \Delta\sigma_{ny} + K_{sxy} \cdot \Delta\sigma_{nx}$ <p>$t_x = \min(t_1, t_2, t_3)$</p> <p>$t_b = \text{minimum among:}$</p> <ul style="list-style-type: none"> – thickness of member above hopper tank top plate, – thickness of member below hopper tank top plate, – t_x. 		
<p>SCANTLINGS:</p> <ul style="list-style-type: none"> • Inner radius of the bent plate to be between 3,5 and 5 times the thickness of the bent plate and to be indicated in the approved plan. • $t_b \geq t_x$. • $t_b \geq t_x$ in portion A. • Thickness of members above and below hopper tank top plate to be not less than that of side transverses. 	<p>FATIGUE:</p> <p>Fatigue check to be carried out for $L \geq 90$ m:</p> <ul style="list-style-type: none"> – $K_{sx} = 3,30$ – $K_{sy} = 1,30$ – $K_{sxy} = 2,25$ 	
<p>CONSTRUCTION:</p> <ul style="list-style-type: none"> • Misalignment (median lines) between hopper tank top plate and hopper tank sloping plate $\leq t_x / 3$. • Misalignment (median lines) between members above and below hopper tank top plate $\leq t_b / 3$. • If not full penetration welding of hopper tank top plate to inner side, the weld preparation is to be indicated on the approved drawings. • Butt welds between inner side and hopper tank sloping plate at a distance greater than 500 mm from the hopper tank top plate. 	<p>NDE:</p> <p>The following NDE are required:</p> <ul style="list-style-type: none"> – VE 100%, – UE 25% of full penetration welds, if any, for absence of cracks, lack of penetration and lamellar tears. 	
<p>WELDING AND MATERIALS:</p> <ul style="list-style-type: none"> • Welding requirements: <ul style="list-style-type: none"> – Welding sequence against the risk of lamellar tearing in the inner side plate is recommended, – Weld finishing well faired to the inner side plating and hopper tank sloping plate. • Material requirements: <ul style="list-style-type: none"> – the radiused construction may be accepted provided that the folding procedure is submitted to the Society for review, with evidence given that the mechanical properties and, in particular, the impact properties are not deteriorated by the folding operation. – material properties of the portion A of the hopper tank sloping plate to be not less than those of the inner side plating. 		

AUXILIARY (CARGO TANK REGIONS)

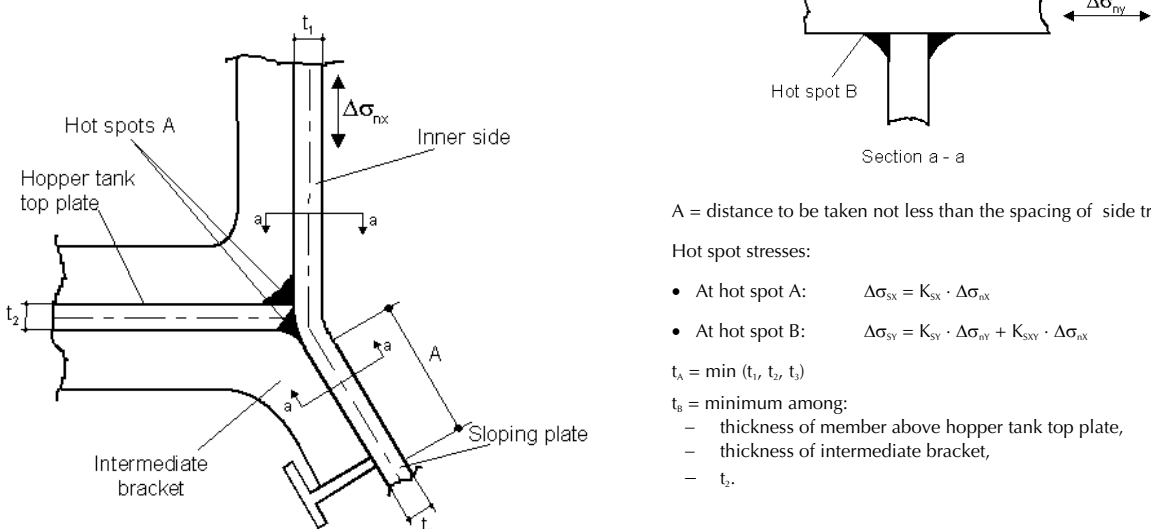
AREA 6: Lower part of inner side	Connection of hopper tank sloping plates with inner side in way of intermediate brackets – Radiused construction	Sheet 6.5
 <p>Hot spots A</p> <p>Hopper tank top plate</p> <p>Intermediate bracket</p> <p>Inner side</p> <p>Sloping plate</p> <p>Hot spot B</p> <p>Section a - a</p> <p>$\Delta\sigma_{nx}$</p> <p>$\Delta\sigma_{ny}$</p> <p>t_1</p> <p>t_2</p> <p>t_3</p> <p>a</p> <p>A</p> <p>$\Delta\sigma_{sx} = K_{sx} \cdot \Delta\sigma_{nx}$</p> <p>$\Delta\sigma_{sy} = K_{sy} \cdot \Delta\sigma_{ny} + K_{sxy} \cdot \Delta\sigma_{nx}$</p> <p>$t_A = \min(t_1, t_2, t_3)$</p> <p>$t_b = \text{minimum among:}$</p> <ul style="list-style-type: none"> - thickness of member above hopper tank top plate, - thickness of intermediate bracket, - t_2. 		
<p>SCANTLINGS:</p> <ul style="list-style-type: none"> • Inner radius of the bent plate to be between 3,5 and 5 times the thickness of the bent plate and to be indicated in the approved plan. • $t_2 \geq t_1$. • $t_3 \geq t_1$ in portion A. • Thickness of intermediate brackets and members above hopper tank top plate to be not less than that of side transverses. 		<p>FATIGUE:</p> <p>Fatigue check to be carried out for $L \geq 90$ m:</p> <ul style="list-style-type: none"> - $K_{sx} = 3,15$ - $K_{sy} = 1,30$ - $K_{sxy} = 2,05$
<p>CONSTRUCTION:</p> <ul style="list-style-type: none"> • Misalignment (median lines) between hopper tank top plate and hopper tank sloping plate $\leq t_A / 3$. • Misalignment (median lines) between intermediate bracket and member below hopper tank top plate $\leq t_b / 3$. • If not full penetration welding of hopper tank top plate to inner side, the weld preparation is to be indicated on the approved drawings. • Intermediate brackets to be fitted in place and welded after the welding of the joint between the hopper tank top plate and the inner side plating. • Butt welds between inner side and hopper tank sloping plate at a distance greater than 500 mm from the hopper tank top plate. 		<p>NDE:</p> <p>The following NDE are required:</p> <ul style="list-style-type: none"> - VE 100%, - UE 25% of full penetration welds, if any, for absence of cracks, lack of penetration and lamellar tears.
<p>WELDING AND MATERIALS:</p> <ul style="list-style-type: none"> • Welding requirements: <ul style="list-style-type: none"> - brackets to be connected with continuous fillet welding to plating and stiffeners, - welding sequence against the risk of lamellar tearing in the inner side plate is recommended, - weld finishing well faired to the inner side plating and hopper tank sloping plate. • Material requirements: <ul style="list-style-type: none"> - the radiused construction may be accepted provided that the folding procedure is submitted to the Society for review, with evidence given that the mechanical properties and, in particular, the impact properties are not deteriorated by the folding operation. - material properties of the portion A of the hopper tank sloping plate to be not less than those of the inner side plating. 		

AUXILIARY (CARGO TANK REGIONS)

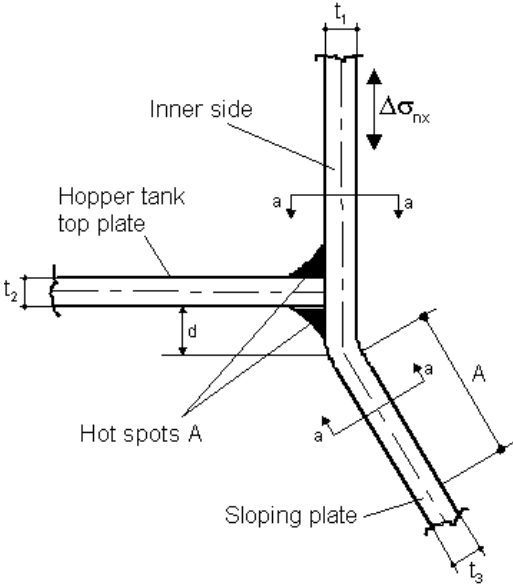
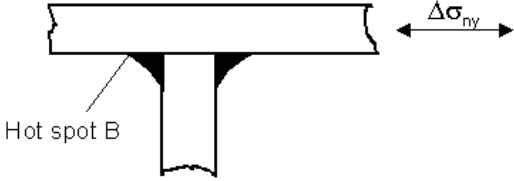
<p>AREA 6: Lower part of inner side</p>	<p>Connection of hopper tank sloping plates with inner side – Radiused construction</p>	<p>Sheet 6.6</p>
<div style="display: flex; justify-content: space-between;"> <div style="width: 45%;">  </div> <div style="width: 45%;">  <p style="text-align: center;">Section a - a</p> <p>A = distance to be taken not less than the spacing of side transverses</p> <p>Hot spot stresses:</p> <ul style="list-style-type: none"> • At hot spot A: $\Delta\sigma_{sx} = K_{sx} \cdot \Delta\sigma_{nx}$ • At hot spot B: $\Delta\sigma_{sy} = K_{sy} \cdot \Delta\sigma_{ny} + K_{sxy} \cdot \Delta\sigma_{nx}$ <p>t = minimum among:</p> <ul style="list-style-type: none"> - thickness of member above hopper tank top plate, - thickness of member below hopper tank top plate, - t_2. </div> </div>		
<p>SCANTLINGS:</p> <ul style="list-style-type: none"> • Inner radius of the bent plate to be between 3,5 and 5 times the thickness of the bent plate and to be indicated in the approved plan. • $d \leq 40$ mm. • $t_2 \geq t_1$. • $t_3 \geq t_1$ in portion A. • Thickness of members above and below hopper tank top plate to be not less than that of side transverses. 	<p>FATIGUE:</p> <p>Fatigue check to be carried out for</p> <p>$L \geq 90$ m:</p> <ul style="list-style-type: none"> - $K_{sx} = 4,50$ - $K_{sy} = 1,30$ - $K_{sxy} = 5,60$ 	
<p>CONSTRUCTION:</p> <ul style="list-style-type: none"> • Misalignment (median lines) between members above and below hopper tank top plate $\leq t / 3$. • If not full penetration welding of hopper tank top plate to inner side, the weld preparation is to be indicated on the approved drawings. • Butt welds between inner side and hopper tank sloping plate at a distance greater than 500 mm from the hopper tank top plate. 	<p>NDE:</p> <p>The following NDE are required:</p> <ul style="list-style-type: none"> - VE 100%, - UE 25% of full penetration welds, if any, for absence of cracks, lack of penetration and lamellar tears. 	
<p>WELDING AND MATERIALS:</p> <p>Material requirements:</p> <ul style="list-style-type: none"> - where hopper tank top plate is welded within the bent area, folding procedure to be submitted to the Society for review, with evidence given that the mechanical properties and, in particular, the impact properties are not deteriorated by the folding operation, - material properties of the portion A of the hopper tank sloping plate to be not less than those of the inner side plating. 		

AUXILIARY (CARGO TANK REGIONS)

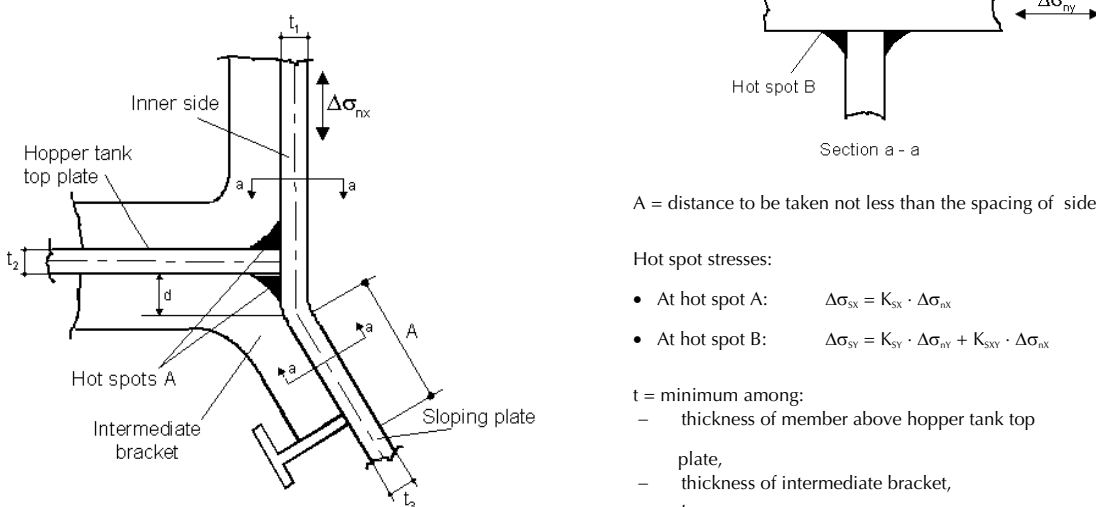
AREA 6: Lower part of inner side	Connection of hopper tank sloping plates with inner side in way of intermediate brackets - Radiused construction	Sheet 6.7
 <p>A = distance to be taken not less than the spacing of side transverses</p> <p>Hot spot stresses:</p> <ul style="list-style-type: none"> • At hot spot A: $\Delta\sigma_{sx} = K_{sx} \cdot \Delta\sigma_{nx}$ • At hot spot B: $\Delta\sigma_{sy} = K_{sy} \cdot \Delta\sigma_{ny} + K_{sxy} \cdot \Delta\sigma_{nx}$ <p>t = minimum among:</p> <ul style="list-style-type: none"> - thickness of member above hopper tank top plate, - thickness of intermediate bracket, - t_2. 		
<p>SCANTLINGS:</p> <ul style="list-style-type: none"> • Inner radius of the bent plate to be between 3,5 and 5 times the thickness of the bent plate and to be indicated in the approved plan. • $d \leq 40$ mm. • $t_2 \geq t_1$. • $t_3 \geq t_1$ in portion A. • Thickness of intermediate brackets and members above hopper tank top plate to be not less than that of side transverses. 		<p>FATIGUE:</p> <p>Fatigue check to be carried out for $L \geq 90$ m:</p> <ul style="list-style-type: none"> - $K_{sx} = 3,85$ - $K_{sy} = 1,30$ - $K_{sxy} = 4,50$
<p>CONSTRUCTION:</p> <ul style="list-style-type: none"> • Misalignment (median lines) between intermediate bracket and member above hopper tank top plate $\leq t/3$. • If not full penetration welding of hopper tank top plate to inner side, the weld preparation is to be indicated on the approved drawings. • Intermediate brackets to be fitted in place and welded after the welding of the joint between the hopper tank top plate and the inner side plating. • Butt welds between inner side and hopper tank sloping plate at a distance greater than 500 mm from the hopper tank top plate. 		<p>NDE:</p> <p>The following NDE are required:</p> <ul style="list-style-type: none"> - VE 100%, - UE 25% of full penetration welds, if any, for absence of cracks, lack of penetration and lamellar tears.
<p>WELDING AND MATERIALS:</p> <p>Material requirements:</p> <ul style="list-style-type: none"> - where hopper tank top plate is welded within the bent area, folding procedure to be submitted to the Society for review, with evidence given that the mechanical properties and, in particular, the impact properties are not deteriorated by the folding operation, - material properties of the portion A of the hopper tank sloping plate to be not less than those of the inner side plating. 		

AUXILIARY (CARGO TANK REGIONS)

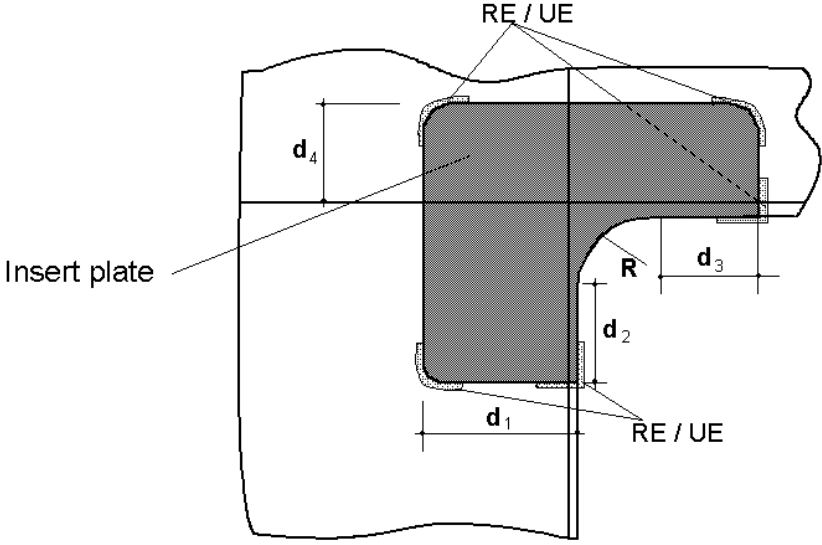
AREA 7: Hatch corners	Deck plating in way of hatch corners	Sheet 7.1
		
<p>SCANTLINGS:</p> <ul style="list-style-type: none"> • Insert plates with circular profiles in general to be fitted in way of corners of hatchways located within the cargo area. The radius of circular corners to be in accordance with Ch 4, Sec 6, [6.2.1]. • Insert plates not required in way of corners of hatchways located in the above positions, where corners have an elliptical or parabolic profile according to Ch 4, Sec 6, [6.2.2]. • Where insert plates are required, their thickness to be defined according to Ch 4, Sec 6, [6.2.3] and their extension to be such that d_1, d_2, d_3 and $d_4 \geq s$, s being the ordinary frame spacing. 		<p>FATIGUE:</p> <p>Fatigue check not required.</p>
<p>CONSTRUCTION:</p> <ul style="list-style-type: none"> • Corners of insert plates to be rounded, unless corresponding to joints of deck strakes. • Insert cut edges to be carefully executed. 		<p>NDE:</p> <p>The following NDE are required:</p> <ul style="list-style-type: none"> – VE 100%, – RE / UE in areas indicated in the sketch.
<p>WELDING AND MATERIALS:</p> <ul style="list-style-type: none"> • Welding requirements: <ul style="list-style-type: none"> – welds recommended to be continued on auxiliary pieces temporarily fitted at the free end of each joint, to be cut away; the joint ends are to be carefully ground. • Materials requirements: <ul style="list-style-type: none"> – insert plate material of same or higher quality than the adjacent deck plating, depending on the insert thickness according to Ch 4, Sec 1, [2]. 		

AUXILIARY (CARGO TANK REGIONS)

AREA 7: Hatch corners	Ends of longitudinal hatch coamings – Bracket welded to deck plating	Sheet 7.2
		<p>t_a = minimum among:</p> <ul style="list-style-type: none"> – thickness of bracket flange at lower end, – deck plating thickness, – under deck transverse stiffener web thickness, <p>t_b = minimum among:</p> <ul style="list-style-type: none"> – bracket web thickness, – deck plating thickness, – thickness of the under deck longitudinal member.
SCANTLINGS:	FATIGUE:	
An additional under deck transverse stiffener is to be fitted in way of termination bracket toe, where the toe is clear of normal stiffener.	Fatigue check not required.	
CONSTRUCTION:	NDE:	
<ul style="list-style-type: none"> • Misalignment between bracket flange and under deck transverse stiffener $\leq t_a / 3$. • Misalignment between bracket and under deck longitudinal $\leq t_b / 3$. 	<p>The following NDE are required:</p> <ul style="list-style-type: none"> – VE 100%, with particular care for the weld shape and undercuts on deck plating at the bracket flange connection, – UE 100% of full penetration welds for absence of cracks, lack of penetration and lamellar tears. 	
WELDING AND MATERIALS:		
<ul style="list-style-type: none"> • Welding requirements: <ul style="list-style-type: none"> – bracket flange to be connected with full penetration welding to deck plating, with half V bevel and weld shape elongated on deck plating (see sketch), – ends of bracket webs to be connected with full penetration welding to deck plating for the extension shown in the sketch, with half X bevel, – under deck transverse stiffener to be connected with full penetration welding to deck plating in way of the bracket flange, – care is to be taken to ensure soundness of the crossing welds at the bracket toe, if the case, adopting small scallop to be closed by welding. 		

AUXILIARY (CARGO TANK REGIONS)

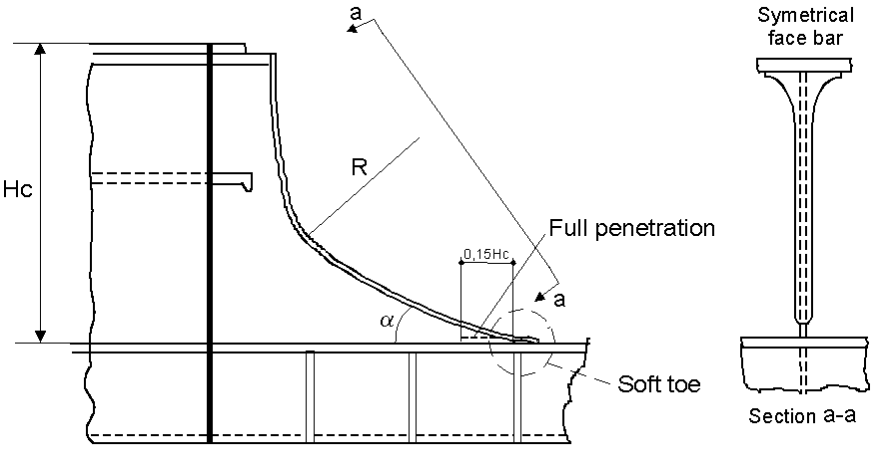
AREA 7: Hatch corners	Ends of longitudinal hatch coamings – Bracket sniped at deck plating	Sheet 7.3
 <p data-bbox="1069 336 1436 492">t = minimum among: – bracket web thickness, – deck plating thickness, – thickness of the under deck longitudinal member.</p>		
SCANTLINGS:	FATIGUE:	
<ul style="list-style-type: none"> • $R \geq 500$ mm. • $\alpha \leq 30^\circ$ 	Fatigue check not required.	
CONSTRUCTION:	NDE:	
<ul style="list-style-type: none"> • Misalignment between bracket and under deck longitudinal $\leq t_b / 3$. • Soft toe: tapering of bracket flange at ends: thickness 1:3, width 1:5. 	The following NDE are required: <ul style="list-style-type: none"> – VE 100%, with particular care for the weld shape and undercuts on deck plating, – UE 100% of full penetration welds for absence of cracks, lack of penetration and lamellar tears. 	
WELDING AND MATERIALS:		
<ul style="list-style-type: none"> • Welding requirements: <ul style="list-style-type: none"> – ends of bracket webs to be connected with full penetration welding to deck plating for the extension shown in the sketch, with half X bevel. 		