



Rules for the Type Approval of Divisions having Resistance to Fire Characteristics in accordance with the IMO FTP Code

Effective from 1 January 2016

Emirates Classification Society (Tasneef)
Aldar HQ 19th Floor,
Al Raha Beach, Abu Dhabi, UAE
Abu Dhabi, United Arab Emirates

Phone (+971) 2 692 2333
Fax (+971) 2 445 433
P.O. Box. 111155
info@tasneef.ae

GENERAL CONDITIONS

Definitions:

"Administration" means the Government of the State whose flag the Ship is entitled to fly or under whose authority the Ship is authorized to operate in the specific case.

"IACS" means the International Association of Classification Societies.

"Interested Party" means the party, other than the Society, having an interest in or responsibility for the Ship, product, plant or system subject to classification or certification (such as the owner of the Ship and his representatives, the ship builder, the engine builder or the supplier of parts to be tested) who requests the Services or on whose behalf the Services are requested.

"Owner" means the registered owner, the ship owner, the manager or any other party with the responsibility, legally or contractually, to keep the ship seaworthy or in service, having particular regard to the provisions relating to the maintenance of class laid down in Part A, Chapter 2 of the Rules for the Classification of Ships or in the corresponding rules indicated in the specific Rules.

"Rules" in these General Conditions means the documents below issued by the Society:

- (i) Rules for the Classification of Ships or other special units;
- (ii) Complementary Rules containing the requirements for product, plant, system and other certification or containing the requirements for the assignment of additional class notations;
- (iii) Rules for the application of statutory rules, containing the rules to perform the duties delegated by Administrations;
- (iv) Guides to carry out particular activities connected with Services;
- (v) Any other technical document, as for example rule variations or interpretations.

"Services" means the activities described in Article 1 below, rendered by the Society upon request made by or on behalf of the Interested Party.

"Ship" means ships, boats, craft and other special units, as for example offshore structures, floating units and underwater craft.

"Society" or "TASNEEF" means Tasneef and/or all the companies in the Tasneef Group which provide the Services.

"Surveyor" means technical staff acting on behalf of the Society in performing the Services.

Article 1

1.1. The purpose of the Society is, among others, the classification and certification of ships and the certification of their parts and components. In particular, the Society:

- (i) sets forth and develops Rules;
- (ii) publishes the Register of Ships;
- (iii) issues certificates, statements and reports based on its survey activities.

1.2. The Society also takes part in the implementation of national and international rules and standards as delegated by various Governments.

1.3. The Society carries out technical assistance activities on request and provides special services outside the scope of classification, which are regulated by these general conditions, unless expressly excluded in the particular contract.

Article 2

2.1. The Rules developed by the Society reflect the level of its technical knowledge at the time they are published. Therefore, the Society, although committed also through its research and development services to continuous updating of the Rules, does not guarantee the Rules meet state-of-the-art science and technology at the time of publication or that they meet the Society's or others' subsequent technical developments.

2.2. The Interested Party is required to know the Rules on the basis of which the Services are provided. With particular reference to Classification Services, special attention is to be given to the Rules concerning class suspension, withdrawal and reinstatement. In case of doubt or inaccuracy, the Interested Party is to promptly contact the Society for clarification. The Rules for Classification of Ships are published on the Society's website: www.tasneef.ae.

2.3. The Society exercises due care and skill:

- (i) in the selection of its Surveyors
- (ii) in the performance of its Services, taking into account the level of its technical knowledge at the time the Services are performed.

2.4. Surveys conducted by the Society include, but are not limited to, visual inspection and non-destructive testing. Unless otherwise required, surveys are conducted through sampling techniques and do not consist of comprehensive verification or monitoring of the Ship or of the items subject to certification. The surveys and checks made by the Society on board ship do not necessarily require the constant and continuous presence of the Surveyor. The Society may also commission laboratory testing, underwater inspection and other checks carried out by and under the responsibility of qualified service suppliers. Survey practices and procedures are selected by the Society based on its experience and knowledge and according to generally accepted technical standards in the sector.

Article 3

3.1. The class assigned to a Ship, like the reports, statements, certificates or any other document or information issued by the Society, reflects the opinion of the Society concerning compliance, at the time the Service is provided, of the Ship or product subject to certification, with the applicable Rules (given the intended use and within the relevant time frame).

The Society is under no obligation to make statements or provide information about elements or facts which are not part of the specific scope of the Service requested by the Interested Party or on its behalf.

3.2. No report, statement, notation on a plan, review, Certificate of Classification, document or information issued or given as part of the Services provided by the Society shall have any legal effect or implication other than a representation that, on the basis of the checks made by the Society, the Ship, structure, materials, equipment, machinery or any other item covered by such document or information meet the Rules. Any such document is issued solely for the use of the Society, its committees and clients or other duly authorised bodies and for no other purpose. Therefore, the Society cannot be held liable for any act made or document issued by other parties on the basis of the statements or information given by the Society. The validity, application, meaning and interpretation of a Certificate of Classification, or any other document or information issued by the Society in connection with its Services, is governed by the Rules of the Society, which is the sole subject entitled to make such interpretation. Any disagreement on technical matters between the Interested Party and the Surveyor in the carrying out of his functions shall be raised in writing as soon as possible with the Society, which will settle any divergence of opinion or dispute.

3.3. The classification of a Ship, or the issuance of a certificate or other document connected with classification or certificate on and in general with the performance of Services by the Society shall have the validity conferred upon it by the Rules of the Society at the time of the assignment of class or issuance of the certificate; in no case shall it amount to a statement or warranty of seaworthiness,

structural integrity, quality or fitness for a particular purpose or service of any Ship, structure, material, equipment or machinery inspected or tested by the Society.

- 3.4. Any document issued by the Society in relation to its activities reflects the condition of the Ship or the subject of certification or other activity at the time of the check.
- 3.5. The Rules, surveys and activities performed by the Society, reports, certificates and other documents issued by the Society are in no way intended to replace the duties and responsibilities of other parties such as Governments, designers, ship builders, manufacturers, repairers, suppliers, contractors or sub-contractors, Owners, operators, charterers, underwriters, sellers or intended buyers of a Ship or other product or system surveyed.

These documents and activities do not relieve such parties from any fulfilment, warranty, responsibility, duty or obligation (also of a contractual nature) expressed or implied or in any case incumbent on them, nor do they confer on such parties any right, claim or cause of action against the Society. With particular regard to the duties of the ship Owner, the Services undertaken by the Society do not relieve the Owner of his duty to ensure proper maintenance of the Ship and ensure seaworthiness at all times. Likewise, the Rules, surveys performed, reports, certificates and other documents issued by the Society are intended neither to guarantee the buyers of the Ship, its components or any other surveyed or certified item, nor to relieve the seller of the duties arising out of the law or the contract, regarding the quality, commercial value or characteristics of the item which is the subject of transaction.

In no case, therefore, shall the Society assume the obligations incumbent upon the above-mentioned parties, even when it is consulted in connection with matters not covered by its Rules or other documents.

In consideration of the above, the Interested Party undertakes to relieve and hold harmless the Society from any third party claim, as well as from any liability in relation to the latter concerning the Services rendered.

Insofar as they are not expressly provided for in these General Conditions, the duties and responsibilities of the Owner and Interested Parties with respect to the services rendered by the Society are described in the Rules applicable to the specific Service rendered.

Article 4

- 4.1. Any request for the Society's Services shall be submitted in writing and signed by or on behalf of the Interested Party. Such a request will be considered irrevocable as soon as received by the Society and shall entail acceptance by the applicant of all relevant requirements of the Rules, including these General Conditions. Upon acceptance of the written request by the Society, a contract between the Society and the Interested Party is entered into, which is regulated by the present General Conditions.

- 4.2. In consideration of the Services rendered by the Society, the Interested Party and the person requesting the service shall be jointly liable for the payment of the relevant fees, even if the service is not concluded for any cause not pertaining to the Society. In the latter case, the Society shall not be held liable for non-fulfilment or partial fulfilment of the Services requested. In the event of late payment, interest at the legal current rate increased by 1.5% may be demanded.

- 4.3. The contract for the classification of a Ship or for other Services may be terminated and any certificates revoked at the request of one of the parties, subject to at least 30 days' notice to be given in writing. Failure to pay, even in part, the fees due for Services carried out by the Society will entitle the Society to immediately terminate the contract and suspend the Services.

For every termination of the contract, the fees for the activities performed until the time of the termination shall be owed to the Society as well as the expenses incurred in view of activities already programmed; this is without prejudice to the right to compensation due to the Society as a consequence of the termination.

With particular reference to Ship classification and certification, unless decided otherwise by the Society, termination of the contract implies that the assignment of class to a Ship is withheld or, if already assigned, that it is suspended or withdrawn; any statutory certificates issued by the Society will be withdrawn in those cases where provided for by agreements between the Society and the flag State.

Article 5

- 5.1. In providing the Services, as well as other correlated information or advice, the Society, its Surveyors, servants or agents operate with due diligence for the proper execution of the activity. However, considering the nature of the activities performed (see art. 2.4), it is not possible to guarantee absolute accuracy, correctness and completeness of any information or advice supplied. Express and implied warranties are specifically disclaimed.

Therefore, except as provided for in paragraph 5.2 below, and also in the case of activities carried out by delegation of Governments, neither the Society nor any of its Surveyors will be liable for any loss, damage or expense of whatever nature sustained by any person, in tort or in contract, derived from carrying out the Services.

- 5.2. Notwithstanding the provisions in paragraph 5.1 above, should any user of the Society's Services prove that he has suffered a loss or damage due to any negligent act or omission of the Society, its Surveyors, servants or agents, then the Society will pay compensation to such person for his proved loss, up to, but not exceeding, five times the amount of the fees charged for the specific services, information or opinions from which the loss or damage derives or, if no fee has been charged, a maximum of AED5,000 (Arab Emirates Dirhams Five Thousand only). Where the fees charged are related to a number of Services, the amount of the fees will be apportioned for the purpose of the calculation of the maximum compensation, by reference to the estimated time involved in the performance of the Service from which the damage or loss derives. Any liability for indirect or consequential loss, damage or expense is specifically excluded. In any case, irrespective of the amount of the fees charged, the maximum damages payable by the Society will not be more than AED5,000,000 (Arab Emirates Dirhams Five Millions only). Payment of compensation under this paragraph will not entail any admission of responsibility and/or liability by the Society and will be made without prejudice to the disclaimer clause contained in paragraph 5.1 above.

- 5.3. Any claim for loss or damage of whatever nature by virtue of the provisions set forth herein shall be made to the Society in writing, within the shorter of the following periods: (i) THREE (3) MONTHS from the date on which the Services were performed, or (ii) THREE (3) MONTHS from the date on which the damage was discovered. Failure to comply with the above deadline will constitute an absolute bar to the pursuit of such a claim against the Society.

Article 6

- 6.1. These General Conditions shall be governed by and construed in accordance with United Arab Emirates (UAE) law, and any dispute arising from or in connection with the Rules or with the Services of the Society, including any issues concerning responsibility, liability or limitations of liability of the Society, shall be determined in accordance with UAE law. The courts of the Dubai International Financial Centre (DIFC) shall have exclusive jurisdiction in relation to any claim or dispute which may arise out of or in connection with the Rules or with the Services of the Society.

- 6.2. However,

- (i) In cases where neither the claim nor any counterclaim exceeds the sum of AED300,000 (Arab Emirates Dirhams Three Hundred Thousand) the dispute shall be referred to the jurisdiction of the DIFC Small Claims Tribunal; and
- (ii) for disputes concerning non-payment of the fees and/or expenses due to the Society for services, the Society shall have the

right to submit any claim to the jurisdiction of the Courts of the place where the registered or operating office of the Interested Party or of the applicant who requested the Service is located.

In the case of actions taken against the Society by a third party before a public Court, the Society shall also have the right to summon the Interested Party or the subject who requested the Service before that Court, in order to be relieved and held harmless according to art. 3.5 above.

Article 7

- 7.1.** All plans, specifications, documents and information provided by, issued by, or made known to the Society, in connection with the performance of its Services, will be treated as confidential and will not be made available to any other party other than the Owner without authorization of the Interested Party, except as provided for or required by any applicable international, European or domestic legislation, Charter or other IACS resolutions, or order from a competent authority. Information about the status and validity of class and statutory certificates, including transfers, changes, suspensions, withdrawals of class, recommendations/conditions of class, operating conditions or restrictions issued against classed ships and other related information, as may be required, may be published on the website or released by other means, without the prior consent of the Interested Party. Information about the status and validity of other certificates and statements may also be published on the website or released by other means, without the prior consent of the Interested Party.
- 7.2.** Notwithstanding the general duty of confidentiality owed by the Society to its clients in clause 7.1 above, the Society's clients hereby accept that the Society may participate in the IACS Early Warning System which requires each Classification Society to provide other involved Classification Societies with relevant technical information on serious hull structural and engineering systems failures, as defined in the IACS Early Warning System (but not including any drawings relating to the ship which may be the specific property of another party), to enable such useful information to be shared and used to facilitate the proper working of the IACS Early Warning System. The Society will provide its clients with written details of such information sent to the involved Classification Societies.
- 7.3.** In the event of transfer of class, addition of a second class or withdrawal from a double/dual class, the Interested Party undertakes to provide or to permit the Society to provide the other Classification Society with all building plans and drawings, certificates, documents and information relevant to the classed unit, including its history file, as the other Classification Society may require for the purpose of classification in compliance with the applicable legislation and relative IACS Procedure. It is the Owner's duty to ensure that, whenever required, the consent of the builder is obtained with regard to the provision of plans and drawings to the new Society, either by way of appropriate stipulation in the building contract or by other agreement.
- In the event that the ownership of the ship, product or system subject to certification is transferred to a new subject, the latter shall have the right to access all pertinent drawings, specifications, documents or information issued by the Society or which has come to the knowledge of the Society while carrying out its Services, even if related to a period prior to transfer of ownership.

Article 8

- 8.1.** Should any part of these General Conditions be declared invalid, this will not affect the validity of the remaining provisions.

INDEX

1 – GENERAL	1
2 – FIELD OF APPLICATION	1
3 – TYPE APPROVAL OF CLASS “A” AND “B” BULKHEADS AND DECKS, CLASS “B” CEILINGS, CLASS “A” WINDOWS, FIRE DAMPERS, PIPE, DUCTS AND CABLE TRANSITS.....	1
3.1 – Test procedure	1
3.2 – Data relevant to the prototype division to be tested.....	1
3.3 – Test specimen.....	1
3.4 – Marking of the specimens	2
4 – TYPE APPROVAL OF CLASS “A” AND “B” DOORS.....	2
4.1 – Test procedure	2
4.2 – Data relevant to the prototype door to be tested	2
4.3 – Test specimen.....	2
4.4 – Marking of the specimen	2
5 – ISSUE AND VALIDITY OF TYPE APPROVAL CERTIFICATE.....	2
6 – RENEWAL OF TYPE APPROVAL CERTIFICATE	3
7 – REPETITION OF THE TESTS.....	3
8 – CONSERVING RECORDS.....	3
ANNEX 1 CLASS “A” BULKHEAD AND DECK DRAWING	
ANNEX 2 CLASS “B” BULKHEAD AND DECK DRAWING	
ANNEX 3 CLASS “B” CEILING DRAWING	
ANNEX 4 CLASS “A” WINDOW DRAWING	
ANNEX 5 DRAWING OF CLASS “A” FIRE DAMPER FITTED ON BULKHEAD	
ANNEX 6 DRAWING OF CLASS “A” FIRE DAMPER FITTED ON DECK	
ANNEX 7 DRAWING OF CLASS “A” CABLE, PIPE AND DUCT PENETRATION FITTED ON BULKHEAD	
ANNEX 8 DRAWING OF CLASS “A” CABLE, PIPE AND DUCT PENETRATION FITTED ON DECK	
ANNEX 9 CLASS “B” DOOR DRAWING	
ANNEX 10 CLASS “A” DOOR DRAWING	
ANNEX 11 TEST SPECIMEN SAMPLING REPORT	
ANNEX 12 LIST OF ACCESSORIES TO BE DELIVERED WITH THE PROTOTYPE DIVISION SPECIMEN	

1 – GENERAL

These requirements define the criteria and the procedures adopted by Tasneef for the type approval of divisions having resistance to fire characteristics in accordance with the procedures contained in Part 3 of Annex 1 of the IMO International Code for Application of Fire Test Procedures (FTP Code), in the following referred to as IMO FTPC Part 3.

2 – FIELD OF APPLICATION

These requirements apply for type approval of the following divisions

1. class “A” bulkheads;
2. class “A” decks;
3. class “B” bulkheads;
4. class “B” decks;
5. class “B” ceilings;
6. windows;
7. fire dampers;
8. pipe and duct penetrations;
9. cable transits;
10. class “A” doors;
11. class “B” doors.

3 – TYPE APPROVAL OF CLASS “A” AND “B” BULKHEADS AND DECKS, CLASS “B” CEILINGS, CLASS “A” WINDOWS, FIRE DAMPERS, PIPE, DUCTS AND CABLE TRANSITS

3.1 – Test procedure

The test and classification procedure defined in IMO FTPC Part 3, which makes application of the IMO Resolution A.754(18) mandatory, shall be applied.

IMO FTPC Annex 2 is also applicable.

3.2 – Data relevant to the prototype division to be tested

The prototype division to undergo the fire resistance test is to be constructed according to the drawings shown in the following Annexes:

Annex 1	class “A” bulkhead and deck
Annex 2	class “B” bulkhead and deck
Annex 3	class “B” ceiling
Annex 4	class “A” window
Annex 5	class “A” fire damper fitted on bulkhead
Annex 6	class “A” fire damper fitted on deck
Annex 7	class “A” cable, pipe and duct penetration fitted on bulkhead
Annex 8	class “A” cable, pipe and duct penetration fitted on deck

The construction drawings of the prototype division, containing the information below, are to be supplied in triplicate and a further two copies in A3:

- dimensions

- detailed list of all the material components and their trade name and manufacturer (full address);
- dimensions and details relative to the insulating material elements used;
- details relative to the method of securing the insulating material;
- details relative to joints, connections and air gaps;
- other significant details.

In particular, as concerns the insulating materials, the following information is to be provided:

- trade name and identification mark;
- manufacturer (full address);
- nominal density (kg/dm³) (indicating any tolerances);
- nominal thickness (mm) (indicating any tolerances);
- description of the composition of the material, indicating, also quantitatively, the main components;
- nominal equilibrium moisture content (at 23 °C and 50% relative humidity);
- specific heat at ambient temperature;
- thermal conductivity at ambient temperature;
- test reports of non-combustibility according to ISO 1182: 1990 with test date not more than 24 months from the date of the fire resistance test.

With regard to the adhesives used in the construction of the specimen of the prototype deck, documentation relative to their type approval as low flame-spread material according to IMO Resolution A.653(16) is to be provided.

3.3 – Test specimen

The specimen of the prototype division is to be built after the drawings in point 3.2 above have been approved by Tasneef.

The specimen is to be constructed under the surveillance of a Tasneef Surveyor; during surveillance one specimen 500 x 500 mm of each type of insulating material used is to be cut.

The Test Specimen Sampling Report (See Annex 11) is to be filled in and signed by the Tasneef Surveyor and the applicant at the time of surveillance of specimen construction and of sampling of insulating material.

The Specimens of insulating material are to be sent to the Tasneef Laboratorio Prove, Calata G. Gadda 16126 Genova, prior to sending the prototype division, for the various measurements foreseen in Res. A.754(18).

The specimen of the prototype division is to be sent to the Tasneef laboratory the day before the test is to be performed, together with steel shapes and nuts and bolts as per the list given in Annex 12 (except for class “B” ceilings) and the means of transport for the specimen must be able to enter the Laboratory’s furnace room so that the specimen can be lifted using the overhead travelling crane or must be able to put the specimen down inside the Laboratory. (entrance clear size of 3750 mm in height.

The applicant is responsible for having the specimen taken away at the end of the tests.

3.4 – Marking of the specimens

Individual insulation specimens are to be contained in a wrapping which is to be marked by the applicant, consisting of the file number assigned, followed by /TYPE (alphanumeric), in the case of different types of materials.

The prototype division is also to be marked, consisting of the file number assigned, followed by / PROGRESSIVE NUMBER in the case of more than one specimen.

All the markings assigned to the specimens should be reported in the Test Specimen Sampling Report.

4 – TYPE APPROVAL OF CLASS “A” AND “B” DOORS

4.1 – Test procedure

The test and classification procedure defined in IMO FTPC Part 3, which makes application of the IMO Resolution A.754(18) mandatory, shall be applied.

IMO FTPC Annex 2 is also applicable.

4.2 – Data relevant to the prototype door to be tested

The prototype door specimen to undergo the fire resistance test is to be constructed according to the drawings shown in the following Annexes:

Annex 9 class “B” door

Annex 10 class “A” door

The construction drawings of the prototype door specimen, containing the information below, are to be supplied in triplicate and a further two copies in A3

- dimensions;
- construction details of the bulkhead in which the door is inserted;
- construction details of the leaves and frame including the air gaps between a leaf and the frame and between the leaves;
- detailed list of all the material components (hinges, shoot bolts, latches, locks, handles, etc.) and relative trade name and manufacturer (full address);
- dimensions and details relative to the insulating material elements used;
- details relative to the method of securing the insulating material;
- details relative to joints and connections between frame and bulkhead;
- other significant details.

In particular, as concerns the insulating materials, the following information is to be provided:

- trade name and identification mark;
- manufacturer (full address);
- nominal density (kg/dm³) (indicating any tolerances);
- nominal thickness (mm) (indicating any tolerances);
- description of the composition of the material, indicating, also quantitatively, the main components;
- nominal equilibrium moisture content (at 23 °C and 50% relative humidity);

- specific heat at ambient temperature;
- thermal conductivity at ambient temperature;
- test reports of non-combustibility according to ISO 1182: 1990 with test date not more than 24 months from the date of the fire resistance test.

With regard to the adhesives used in the construction of the specimen of the prototype door, documentation relative to their type approval as low flame-spread material according to IMO Resolution A.653(16) is to be provided.

4.3 – Test specimen

The specimen of the prototype door is to be built after the drawings in point 4.2 above have been approved by Tasneef Head Office.

The specimen is to be constructed under the surveillance of a Tasneef Surveyor; during surveillance one specimen 500 x 500 mm of each type of insulating material used is to be cut.

The Test Specimen Sampling Report (See Annex 11) is to be filled in and signed by the Tasneef Surveyor and the applicant at the time of surveillance of specimen construction and of sampling of insulating material. The specimens of insulating material are to be sent to the Tasneef Laboratorio Prove, Calata G. Gadda 16126 Genova, prior to sending the prototype division, for the various measurements foreseen in Res. A.754(18).

The specimen of the prototype door is to be sent to the Tasneef laboratory the day before the test is to be performed, together with steel shapes and nuts and bolts as per the list given in Annex 12 and the means of transport for the specimen must be able to enter the Laboratory’s furnace room so that the specimen can be lifted using the overhead travelling crane or must be able to put the specimen down inside the Laboratory. (entrance clear size of 3750 mm in height).

The applicant is responsible for having the specimen taken away at the end of the tests.

4.4 – Marking of the specimen

Individual insulation specimens are to be contained in a wrapping which is to be marked by the applicant, consisting of the file number assigned, followed by /TYPE (alphanumeric), in the case of different types of materials.

The prototype door specimen is also to be marked, consisting of the file number assigned, followed by / PROGRESSIVE NUMBER in the case of more than one specimen.

All the markings assigned to the specimens should be reported in the Test Specimen Sampling Report.

5 – ISSUE AND VALIDITY OF TYPE APPROVAL CERTIFICATE

Subject to the satisfactory outcome of the required checks and tests, Tasneef Head Office issues to the applicant a “Type approval certificate” valid for the division subjected to the type tests.

The “Type approval certificate” is valid for five years from the date of issue.

6 – RENEWAL OF TYPE APPROVAL CERTIFICATE

In order to renew the “Type approval certificate”, an application, together with the technical sheet, is to be submitted to Tasneef Head Office with indication of any modifications in respect of the previous approval.

On the basis of the check of such documentation, Tasneef will establish the checks and tests to be carried out in order to renew the “Type approval certificate”.

7 – REPETITION OF THE TESTS

Tasneef reserves the right to repeat type tests, wholly or in part, in the case of modification of the rules on the basis of which the type approval was issued, in the event of doubts or complaints or when the test reports are particularly dated.

8 – CONSERVING RECORDS

The file records, consisting of:

- Activity contracts and their reviews;
- Test reports;
- Worksheets;
- Specimen sampling reports;
- Type approval certificates

are to be kept for at least 10 years, plus the current year, from the date of the last activity.

ANNEX 1 - CLASS "A" BULKHEAD AND DECK DRAWING

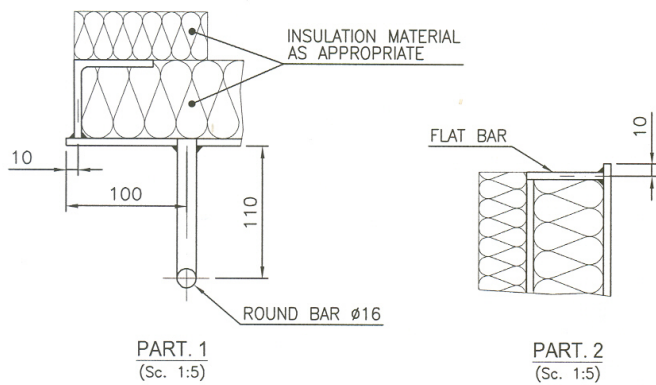
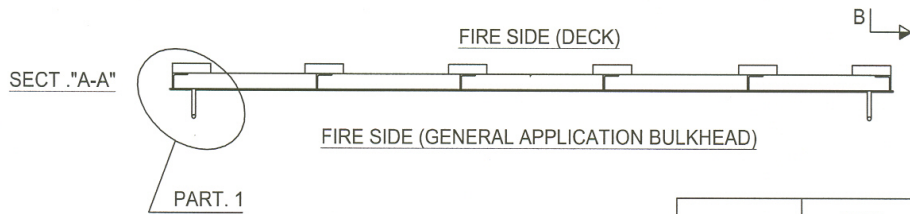
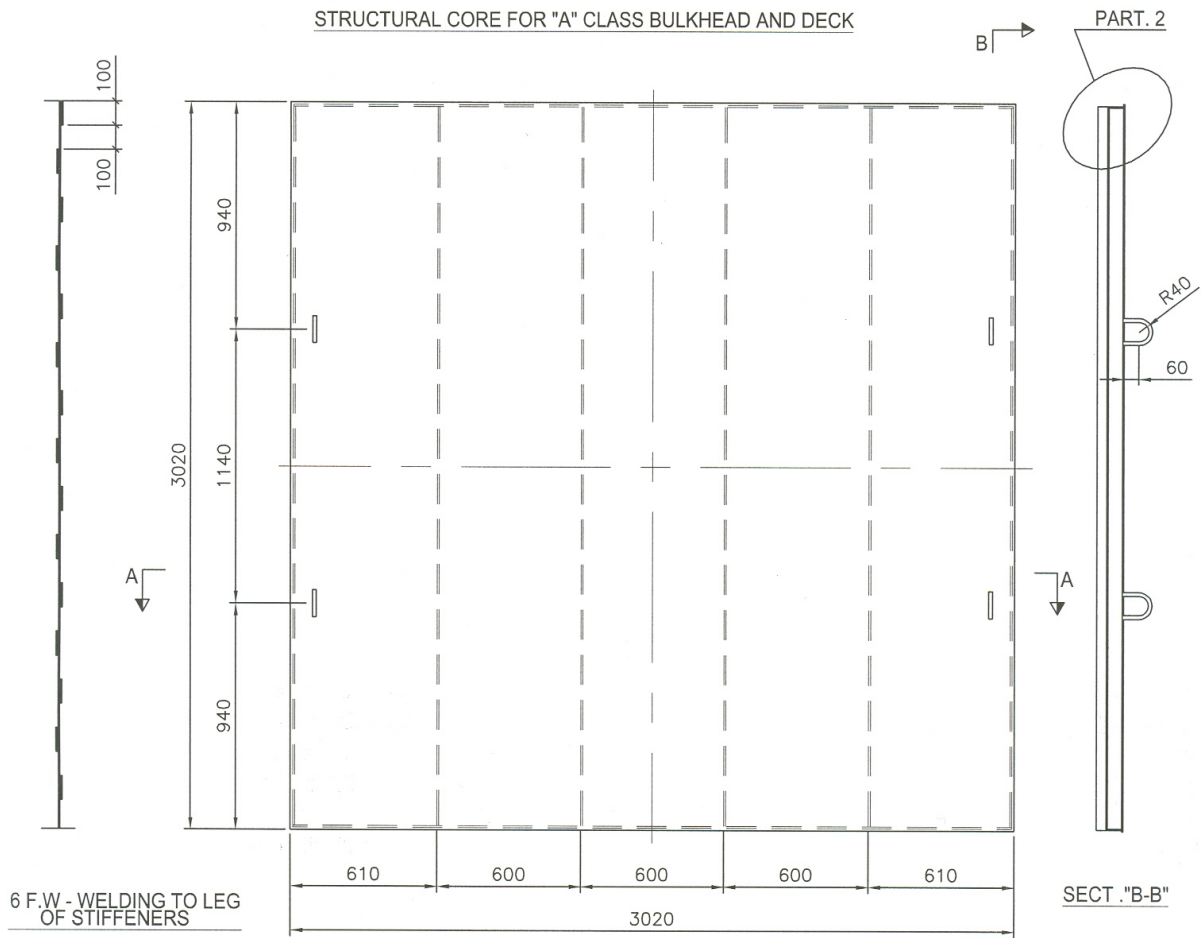

		STEEL	L.ALLOY
BULKHEAD	PLATE	4.5 (± 0.5)	6 (± 0.5)
	STIFFENERS	65x65 (± 5) th. 6 (± 1)	100x75 (± 5) th. 9 (± 1)
	FLAT BAR	65(± 5)x6(± 1)	100(± 5)x8(± 1)
DECK	PLATE	4.5 (± 0.5)	6 (± 0.5)
	STIFFENERS	100x70 (± 5) th. 8 (± 1)	150x100 (± 5) th. 9 (± 1)
	FLAT BAR	100(± 5)x8(± 1)	150(± 5)x9(± 1)

ANNEX No.1

ANNEX 2 - CLASS "B" BULKHEAD AND DECK DRAWING

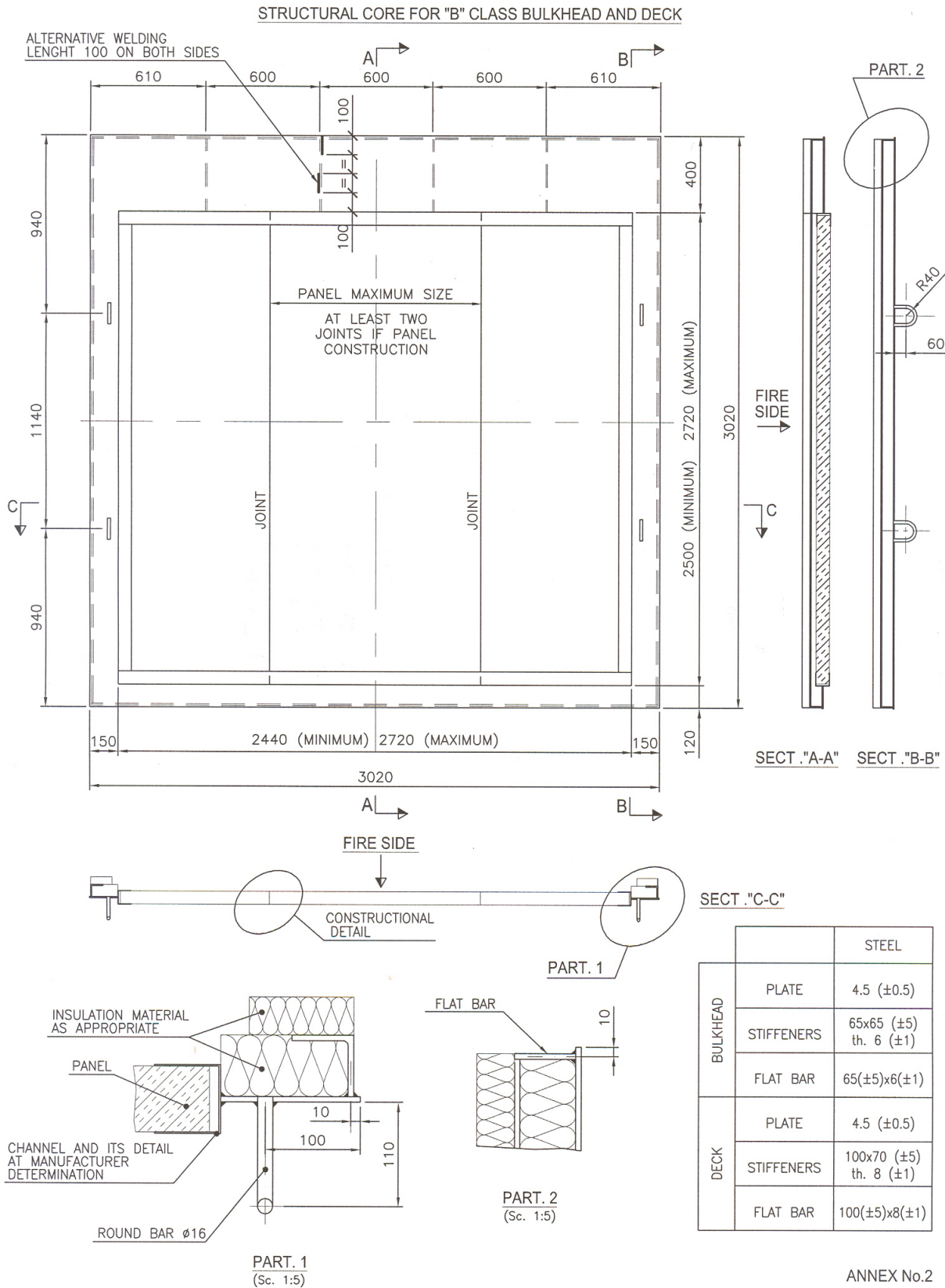

ANNEX 4 - CLASS "A" WINDOW DRAWING

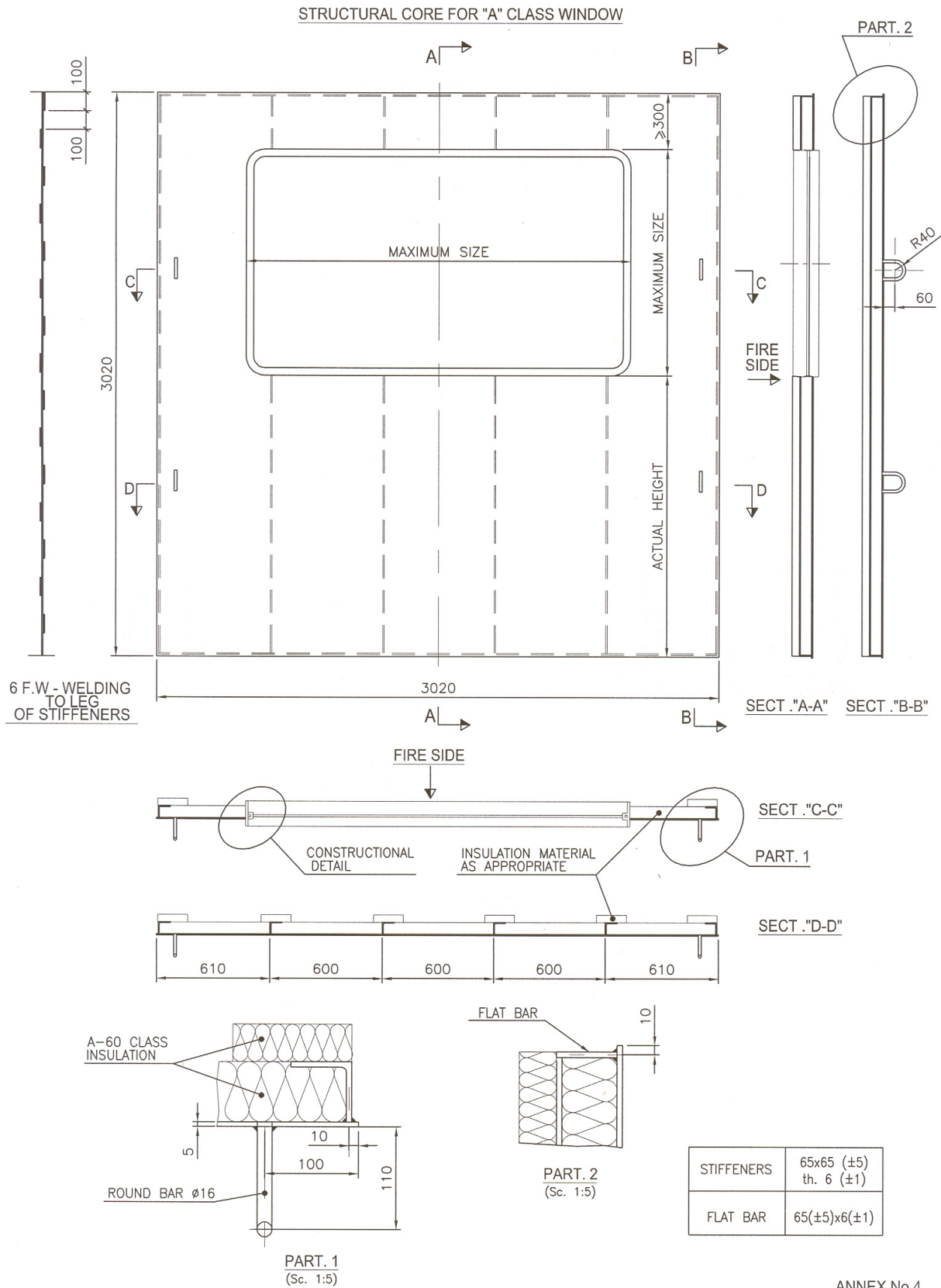

ANNEX 5 - DRAWING OF CLASS "A" FIRE DAMPER FITTED ON BULKHEAD

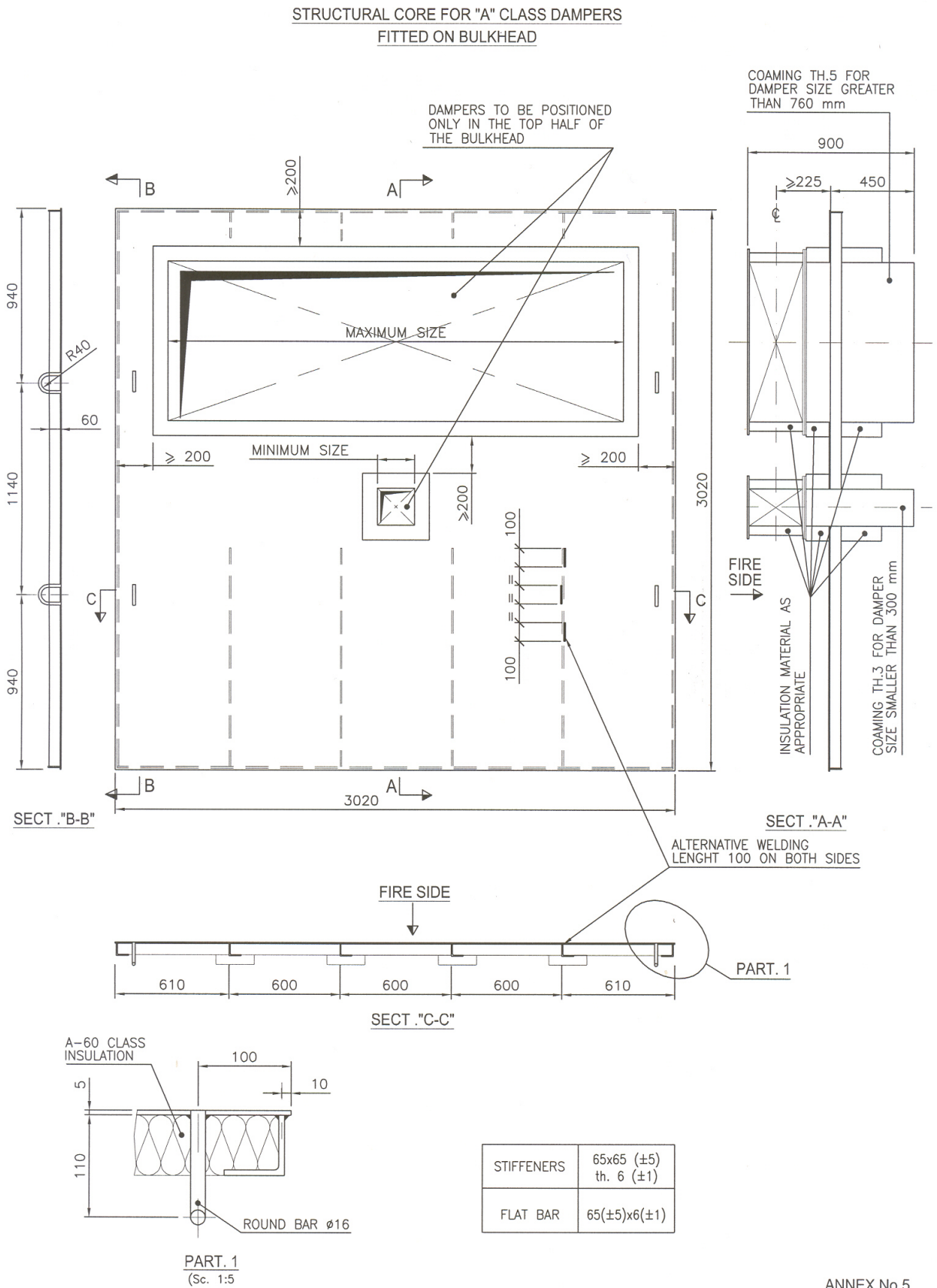

ANNEX 6 - DRAWING OF CLASS "A" FIRE DAMPER FITTED ON DECK

STRUCTURAL CORE FOR "A" CLASS DAMPERS
FITTED ON DECK

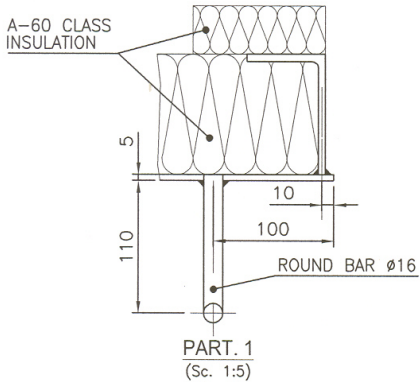
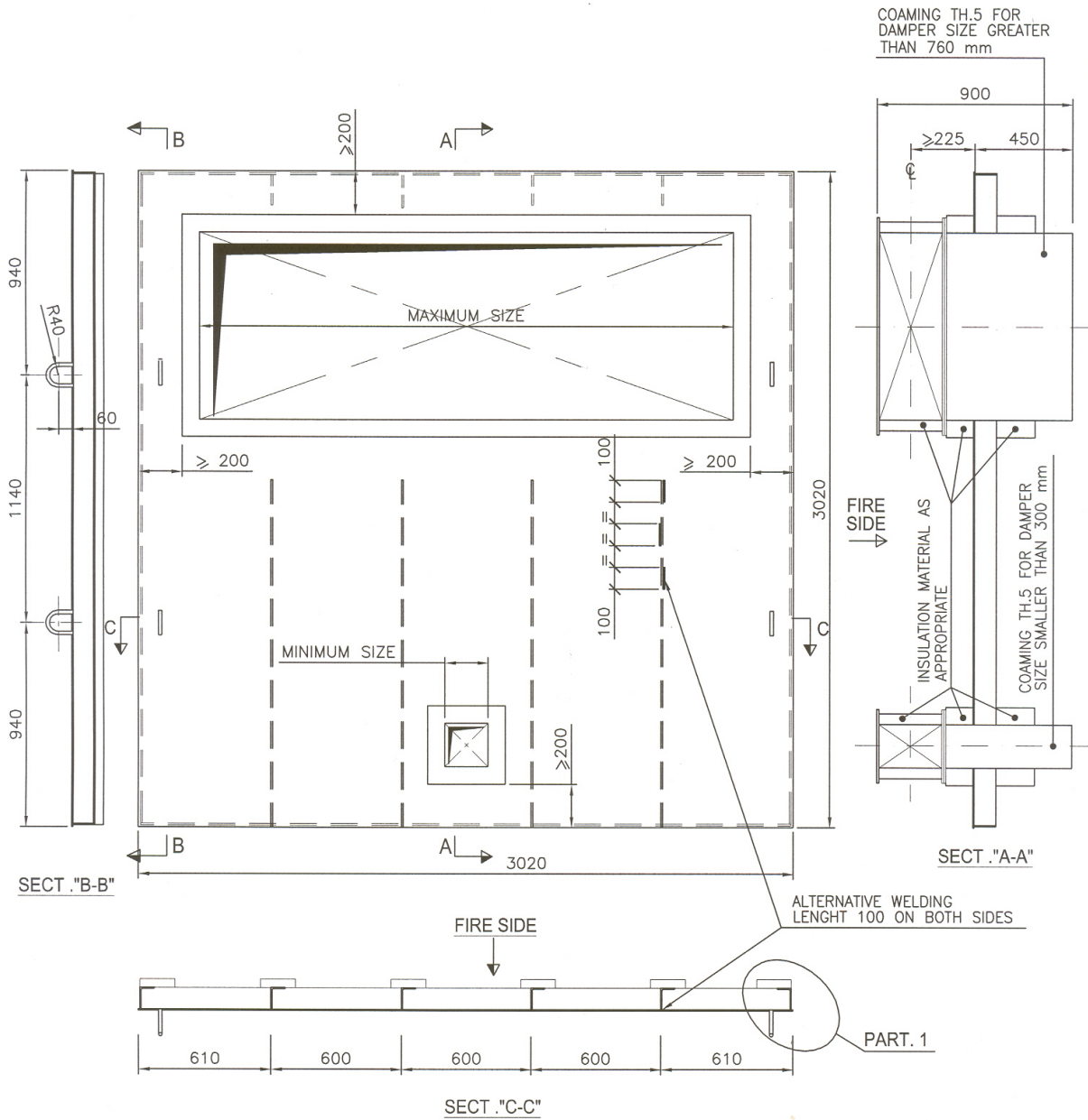

STIFFENERS	100x70 (±5) th. 8 (±1)
FLAT BAR	100(±5)x8(±1)

ANNEX No.6

ANNEX 9 CLASS "B" DOOR DRAWING

STRUCTURAL CORE FOR "B" CLASS DOOR

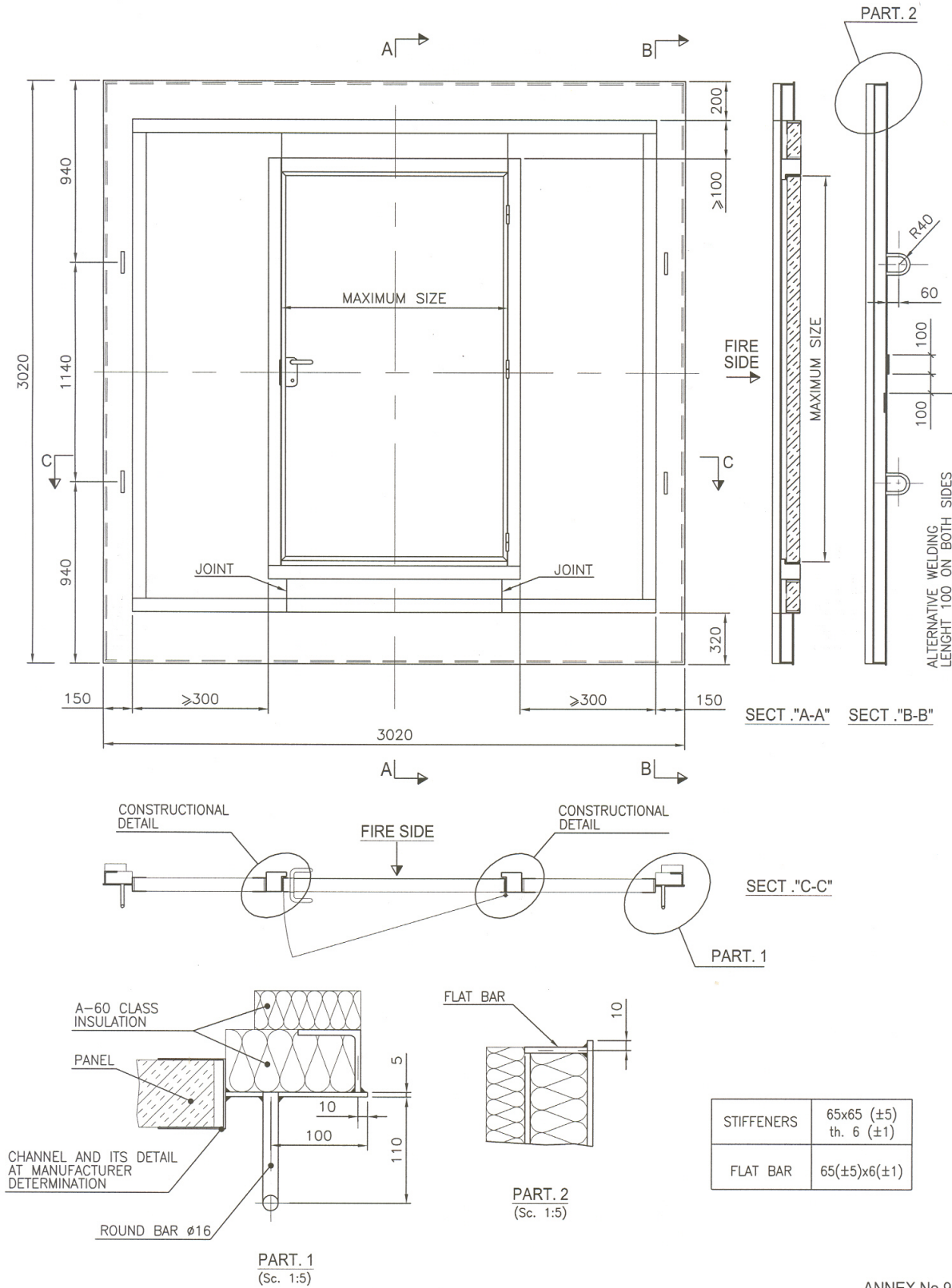

ANNEX No.9

ANNEX 10 CLASS "A" DOOR DRAWING

STRUCTURAL CORE FOR "A" CLASS DOOR

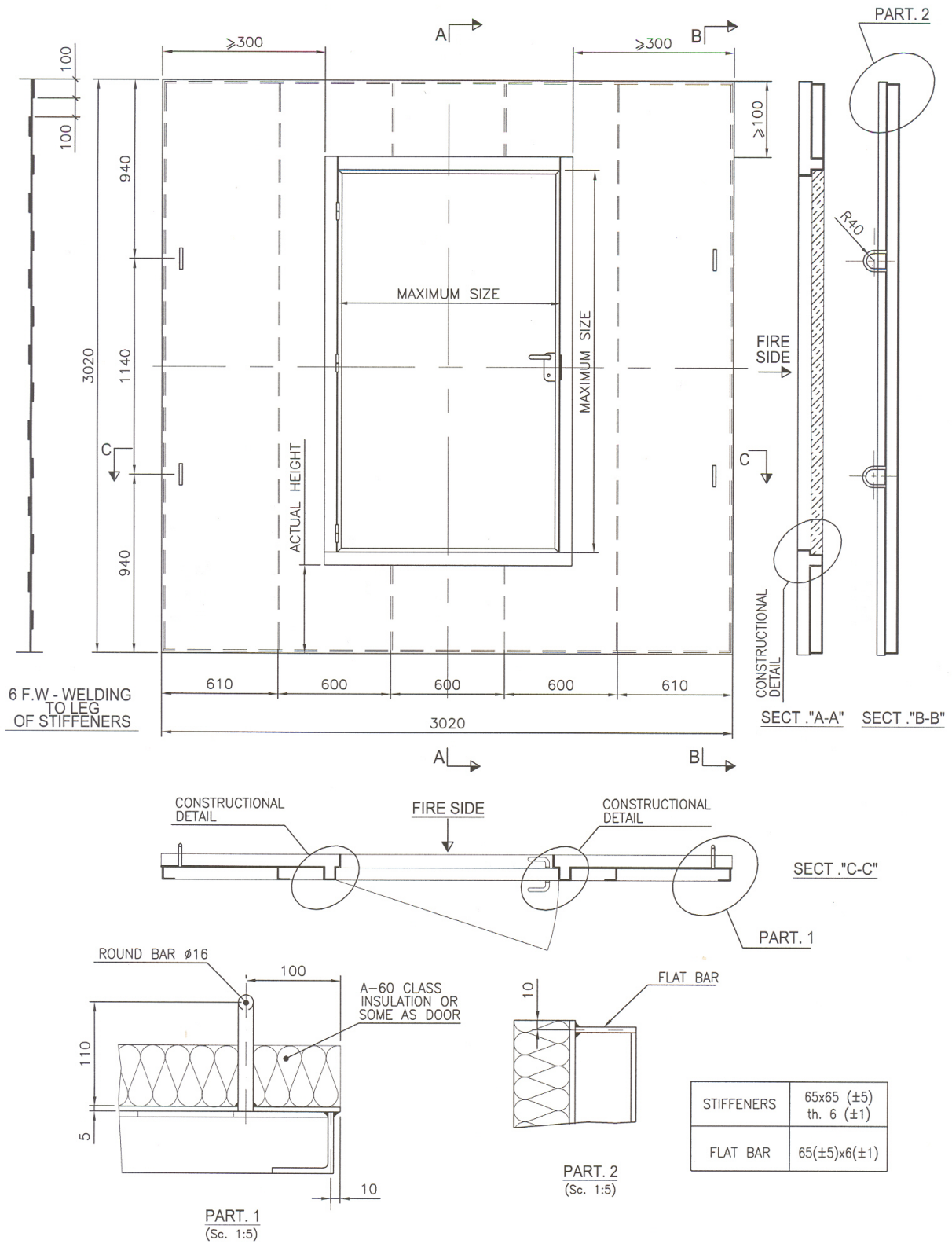

ANNEX 11 TEST SPECIMEN SAMPLING REPORT



File		CS	01	
------	--	----	----	--

Sheet 1	of	
---------	----	--

Name and address of the applicant

Name and characteristics of the material to be tested

Sampling location

Type of test	Specimen marking

Notes

Date Applicant Tasneef Surveyor

ANNEX 12 LIST OF ACCESSORIES TO BE DELIVERED WITH THE PROTOTYPE DIVISION SPECIMEN

- 1) 25 L shaped steel pieces, 100 mm long, with equal flanges 50 x 50 x 5 to be welded in loco during assembly of the specimen.

A slot is to be made on one flange as shown below:

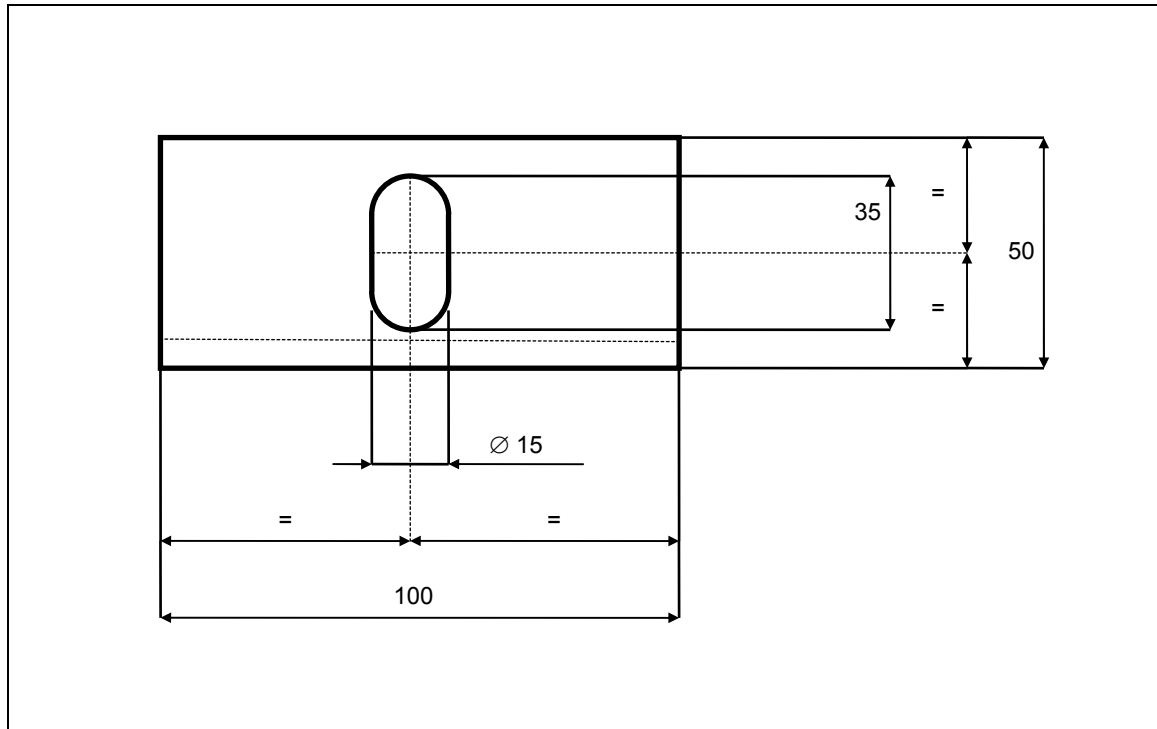

- 2) 25 screws M12 x100 mm
- 3) 25 nuts M12
- 4) 25 washers \varnothing_i 14 mm