

Rules for the Classification of Offshore Units Operating in the Caspian Sea and Similar Areas

Effective from 1 January 2023

Part C

Machinery, Systems and Fire Protection

GENERAL TERMS AND CONDITIONS
OF EMIRATES CLASSIFICATION SOCIETY – L.L.C – O.P.C (TASNEEF)
EFFECTIVE AS OF 1 APRIL 2025

DEFINITIONS

Administration	means the government of the state whose flag the Ship is entitled to fly or under whose authority the Ship is authorised to operate in the specific case.
Client	means the interested party and any other party who requires the Services.
Certificate of Classification	means a certificate of classification, issued by a Society and the certificate confirms that the vessel's structure, machinery, and equipment meet the society's specific technical rules and regulations.
Interested Party	means the party, other than the society, having an interest in or responsibility for the Ship, product, plant or system subject to classification or certification (such as the owner of the Ship and his representatives, the Ship builder, the engine builder or the supplier of parts to be tested) who requests the Services or on whose behalf the Services are requested.
Owner	means the registered owner, the Ship owner, the manager or any other party with the responsibility, legally or contractually, to keep the Ship seaworthy or in service, having particular regard to the provisions relating to the maintenance of class laid down in part a, chapter 2 of the rules for the classification of Ships or in the corresponding rules indicated in the specific rules.
Register of Ships	means a register book, also known as a Register of Ships, is a comprehensive record of vessels that are classified by a society.
Rules	means the documents below issued by the Society: <ul style="list-style-type: none"> a. Rules for the classification of Ships or other special units. b. Complementary rules containing the requirements for certification of products, plants, systems and other or containing the requirements for the assignment of additional class notations. c. Rules for the application of statutory rules, containing the rules to perform the duties delegated by administrations. d. Guides to carry out particular activities connected with Services. e. Any other technical document, as for example rule variations or interpretations.

**GENERAL TERMS AND CONDITIONS
OF EMIRATES CLASSIFICATION SOCIETY – L.L.C – O.P.C (TASNEEF)
EFFECTIVE AS OF 1 APRIL 2025**

DEFINITIONS

Administration	means the government of the state whose flag the Ship is entitled to fly or under whose authority the Ship is authorised to operate in the specific case.
Client	means the interested party and any other party who requires the Services.
Certificate of Classification	means a certificate of classification, issued by a Society and the certificate confirms that the vessel's structure, machinery, and equipment meet the society's specific technical rules and regulations.
Interested Party	means the party, other than the society, having an interest in or responsibility for the Ship, product, plant or system subject to classification or certification (such as the owner of the Ship and his representatives, the Ship builder, the engine builder or the supplier of parts to be tested) who requests the Services or on whose behalf the Services are requested.
Owner	means the registered owner, the Ship owner, the manager or any other party with the responsibility, legally or contractually, to keep the Ship seaworthy or in service, having particular regard to the provisions relating to the maintenance of class laid down in part a, chapter 2 of the rules for the classification of Ships or in the corresponding rules indicated in the specific rules.
Register of Ships	means a register book, also known as a Register of Ships, is a comprehensive record of vessels that are classified by a society.
Rules	means the documents below issued by the Society: <ul style="list-style-type: none"> a. Rules for the classification of Ships or other special units. b. Complementary rules containing the requirements for certification of products, plants, systems and other or containing the requirements for the assignment of additional class notations. c. Rules for the application of statutory rules, containing the rules to perform the duties delegated by administrations. d. Guides to carry out particular activities connected with Services. e. Any other technical document, as for example rule variations or interpretations.

Services	means the activities described in Article 1 below, rendered by the Society upon request made by or on behalf of the Interested Party.
Ship	means ships, boats, craft and other special units, as for example offshore structures, floating units and underwater craft.
Society	means Emirates Classification Society LLC OPC and/or its affiliated entities providing the Services.
Surveyor	means technical staff acting on behalf of the society in performing the Services.
UAE	means United Arab Emirates.

ARTICLE 1

- 1.1 The purpose of the Society is, among others, the classification and certification of Ships and the certification of their parts and components.
- 1.2 The Society (a) sets forth and develops Rules; (b) publishes the Register of Ships¹; and (c) issues certificates, statements and reports based on its survey activities.
- 1.3 The Society also takes part in the implementation of national and international rules and standards as delegated by various Governments.
- 1.4 The Society carries out technical assistance activities on request and provides special services outside the scope of classification, which is regulated by these general conditions unless expressly excluded in the particular contract.

ARTICLE 2

- 2.1 The Rules developed by the Society reflect the level of its technical knowledge at the time they are published. Therefore, the Society, though committed, also through its research and development services, to continuous updating, does not guarantee they meet state-of-the-art science and technology at the time of publication or that they meet the Society's or others' subsequent technical developments.
- 2.2 The Interested Party is required to know the Rules on the basis of which the Services are provided. With particular reference to Classification Services, special attention is to be given to the Rules concerning class suspension, withdrawal and reinstatement. In case of doubt or inaccuracy, the Interested Party is to promptly contact the Society for clarification. The Rules for Classification of Ships are published on the Society's website: www.tasneefmaritime.ae
- 2.3 The Society exercises due care and skill:
 - (a) in the selection of its Surveyors; and
 - (b) in the performance of its Services, taking into account the level of its technical knowledge at the time the

Services are performed.

- 2.4 Surveys conducted by the Society include, but are not limited to, visual inspection and non-destructive testing. Unless otherwise required, surveys are conducted through sampling techniques and do not consist of comprehensive verification or monitoring of each component of the Ship or of the items subject to certification. The surveys and checks made by the Society, either on board Ships or with remote techniques, do not necessarily require the constant and continuous presence of the Surveyor. The Society may also commission laboratory testing, underwater inspection and other checks to qualified service suppliers, who will carry out these duties under their responsibility. Survey practices and procedures are selected by the Society based on its experience and knowledge and according to generally accepted technical standards in the sector.

ARTICLE 3

- 3.1 The class assigned to a Ship, like the reports, statements, certificates or any other document or information issued by the Society, reflect the discretionary opinion of the Society concerning compliance, at the time the Service is provided, of the Ship or product subject to certification, with the applicable Rules (given the intended use and within the relevant time frame).
- 3.2 The Society is under no obligation to make statements or provide information about elements or facts which are not part of the specific scope of the Service requested by the Interested Party or on its behalf.
- 3.3 No report, statement, notation on a plan, review, Certificate of Classification, document or information issued or given as part of the Services provided by the Society shall have any legal effect or implication other than a representation that, on the basis of the checks made by the Society, the Ship, structure, materials, equipment, machinery or any other item covered by such document or information meet the Rules. Any such document is issued solely for the use of the Society, its committees and clients or other duly authorised bodies and for no other purpose. Therefore, the Society cannot be held liable for any act made or document issued by other parties on the basis of the statements or information given by the Society. The validity, application, meaning and interpretation of a Certificate of Classification, or any other document or information issued by the Society in connection with its Services, are governed by the Rules of the Society, whom is the sole subject entitled to make such authentic interpretation. Any disagreement on technical matters between the Interested Party and the Surveyor in the carrying out of his functions shall be raised in writing as soon as possible with the Society, which will settle any divergence of opinion or dispute.
- 3.4 The classification of a Ship, or the issuance of a certificate or other document connected with classification or certification and in general with the performance of Services by the Society shall have the validity conferred upon it by the Rules of the Society at the time of the assignment of class or issuance of the certificate; in no case shall it amount to a statement or warranty of seaworthiness, structural integrity, quality or fitness for a particular purpose or service of any Ship, structure, material, equipment or machinery inspected or tested by the Society.
- 3.5 Any document issued by the Society in relation to its activities reflects the condition of the Ship or the subject of certification or other activity at the time of the check.
- 3.6 The Rules, surveys and activities performed by the Society, reports, certificates and other documents issued by

the Society are in no way intended to replace the duties and responsibilities of other parties including, without limitation, Governments, designers, ship builders, manufacturers, repairers, suppliers, contractors or sub-contractors, Owners, operators, charterers, underwriters, sellers or intended buyers of a Ship or other product or system surveyed.

- 3.7 These documents and activities do not relieve such parties from any fulfilment, warranty, responsibility, duty or obligation (also of a contractual nature) expressed or implied or in any case incumbent on them, nor do they confer on such parties any right, claim or cause of action against the Society. With particular regard to the duties of the Owner, the Services undertaken by the Society do not relieve the Owner of his duty to ensure proper maintenance of the Ship and ensure seaworthiness at all times. Likewise, the Rules, surveys performed, reports, certificates and other documents issued by the Society are intended neither to guarantee the buyers of the Ship, its components or any other surveyed or certified item, nor to relieve the seller of the duties arising out of the law or the contract, regarding the quality, commercial value or characteristics of the item which is the subject of transaction.
- 3.8 In no case, therefore, shall the Society assume the obligations incumbent upon the above-mentioned parties, even when it is consulted in connection with matters not covered by its Rules or other documents.
- 3.9 In consideration of the above, and within the limits of liability under Article 5 below, the Interested Party undertakes to relieve and hold harmless the Society from any third party claim, as well as from any liability in relation to the latter concerning the Services rendered, where these are attributable to the Interested Party.
- 3.10 Insofar as they are not expressly provided for in these General Conditions, the duties and responsibilities of the Owner and Interested Parties with respect to the Services rendered by the Society are described in the Rules applicable to the specific Service rendered.

ARTICLE 4

- 4.1 Any request for the Society's Services shall be submitted in writing and signed by or on behalf of the Interested Party. Such a request will be considered irrevocable as soon as received by the Society and shall entail acceptance by the applicant of all relevant requirements of the Rules, including these General Conditions. Upon acceptance of the written request by the Society, a contract between the Society and the Interested Party is entered into, which is regulated by the present General Conditions.
- 4.2 In consideration of the Services rendered by the Society, the Interested Party and the person requesting the service shall be jointly liable for the payment of the relevant fees and costs, even if the service is not concluded for any cause not pertaining to the Society. In the latter case, the Society shall not be held liable for non-fulfilment or partial fulfilment of the Services requested. In the event of non-payment of the invoice within the contractually agreed terms, the Society reserves the right to request, in addition to the full payment of the principal amount due and without the need for further formal notice, also:
- (a) Late payment interest at a rate of 5% per annum, calculated from the due date of the invoice until full payment is received, in accordance with the applicable laws in the United Arab Emirates or the country from where the invoice is issued. Any applicable VAT, taxes, or statutory levies shall be borne by the Client as per the laws

- of the respective jurisdiction;
- (b) full reimbursement of any costs incurred for debt recovery, including, but not limited to, legal fees, administrative expenses, and the costs of any extrajudicial actions; and
 - (c) any additional amount due as compensation for damages suffered as a result of the delay or non-compliance, where documented.
- 4.3 The contract for the classification of a Ship or for other Services may be terminated and any certificates revoked at the request of one of the parties, subject to at least 30 days' notice to be given in writing. Failure to pay, even in part, the fees due for Services carried out by the Society will entitle the Society to immediately terminate the contract and suspend the Services.
- 4.4 The Society may withhold, suspend or withdraw any certificate, report or service in the event of non-payment of fees due to any member of the Society by the Client in relation to the entire business relationship between any member of the Society and the Client or by any other companies belonging to the same group as the Client. This also applies when the obligation to pay rests with a builder or with the Ship's previous Owner.
- 4.5 For every case of termination or suspension of the contract, the fees for the activities performed until the time of the termination or of the suspension shall be owed to the Society as well as the expenses incurred in view of activities already programmed; this is without prejudice to the right to compensation due to the Society as a consequence of the termination or of the suspension.
- 4.6 With particular reference to Ship classification and certification, unless decided otherwise by the Society, termination of the contract implies that the assignment of class to a Ship is withheld or, if already assigned, that it is suspended or withdrawn; any statutory certificates issued by the Society will be withdrawn in those cases where provided for by agreements between the Society and the flag State.

ARTICLE 5

- 5.1 In providing the Services, as well as other correlated information or advice, the Society, its Surveyors, servants or agents operate with due diligence for the proper execution of the activity. However, considering the nature of the activities performed (see Article 2), it is not possible to guarantee absolute accuracy, correctness and completeness of any information or advice supplied. Express and implied warranties are specifically disclaimed.
- 5.2 Therefore, subject to what provided for in Article 5.3 below, and also in the case of activities carried out by delegation of Governments, neither the Society nor any of its Surveyors will be liable for any loss, damage or expense of whatever nature sustained by any person, in tort or in contract, derived from carrying out the Services.
- 5.3 Notwithstanding the provisions in Article 5.1 above, should any user of the Society's Services prove that he has suffered a loss or damage due to any negligent act or omission of the Society, its Surveyors, servants or agents, then the Society will pay compensation to such person for his proved loss, up to, but not exceeding, five times the amount of the fees charged for the specific Services, information or opinions from which the loss or damage derives or, if no fee has been charged, a maximum of AED5,000 (Arab Emirates Dirhams Five Thousand only).
- 5.4 Where the fees charged are related to a number of Services, the amount of the fees will be apportioned for the purpose of the calculation of the maximum compensation, by reference to the estimated time involved in the

performance of the Service from which the damage or loss derives. Any liability for indirect or consequential loss, damage or expense is specifically excluded. In any case, irrespective of the amount of the fees charged, the maximum damages payable by the Society will not be more than AED 300,000 (Three Hundred Thousand Dirhams). Payment of compensation under this Article will not entail any admission of responsibility and/or liability by the Society and will be made without prejudice to the disclaimer clause contained in Article 5.

- 5.5 Any claim for loss or damage of whatever nature by virtue of the provisions set forth herein shall be made to the Society in writing, within the shorter of the following periods: THREE MONTHS from the date on which the Services were performed or THREE MONTHS from the date on which the damage was discovered. Failure to comply with the above deadline will constitute an absolute bar to the pursuit of such a claim against the Society.

ARTICLE 6

- 6.1 Any dispute, controversy, or claim arising out of or relating to these Rules, the Services of the Society, or the interpretation, breach, or termination thereof, shall first be referred to the parties' senior management for amicable resolution within thirty (30) days of written notice by either party.
- 6.2 If the dispute is not resolved amicably under Article 6.1, it shall be exclusively governed by and construed in accordance with the laws of the Emirate of Abu Dhabi and the applicable federal laws of the United Arab Emirates. The courts of Abu Dhabi shall have exclusive jurisdiction to settle any such dispute.

ARTICLE 7

- 7.1 All plans, specifications, documents and information provided by, issued by, or made known to the Society, in connection with the performance of its Services, will be treated as confidential and will not be made available to any other party other than the Owner without authorisation of the Interested Party, except as provided for or required by any applicable legislation from a competent authority. Information about the status and validity of class and statutory certificates, including transfers, changes, suspensions, withdrawals of class, conditions of class, operating conditions or restrictions issued against classed ships and other related information, as may be required, may be published on the website or released by other means, without the prior consent of the Interested Party.
- 7.2 Information about the status and validity of other certificates and statements may also be published on the website or released by other means, without the prior consent of the Interested Party.
- 7.3 Notwithstanding the general duty of confidentiality owed by the Society to its clients in Article 7.1 above, the Society's clients hereby accept that the Society will participate in the IACS Early Warning System which requires each Classification Society to provide other involved Classification Societies with relevant technical information on serious hull structural and engineering systems failures, as defined in the IACS Early Warning System (but not including any drawings relating to the Ship which may be the specific property of another party), to enable such useful information to be shared and used to facilitate the proper working of the IACS Early Warning System. The Society will provide its clients with written details of such information sent to the involved Classification Societies.
- 7.4 In the event of transfer of class, addition of a second class or withdrawal from a double/dual class, the Interested Party undertakes to provide or to permit the Society to provide the other Classification Society with all building plans and drawings, certificates, documents and information relevant to the classed unit, including its history file,

as the other Classification Society may require for the purpose of classification in compliance with the applicable legislation and relative IACS Procedure. It is the Owner's duty to ensure that, whenever required, the consent of the builder is obtained with regard to the provision of plans and drawings to the new Society, either by way of appropriate stipulation in the building contract or by other agreement.

- 7.5 In the event that the ownership of the Ship, product or system subject to certification is transferred to a new subject, the latter shall have the right to access all pertinent drawings, specifications, documents or information issued by the Society or which have come to the knowledge of the Society while carrying out its Services, even if related to a period prior to transfer of ownership.

ARTICLE 8

- 8.1 The Society shall not be obliged to perform any obligation towards the Client (including, without limitation, obligation to (a) perform, deliver, accept, sell, purchase, pay or receive money to, from or through a person or entity, or (b) engage in any other act) if this would be in violation of, inconsistent with or expose the Society to punitive measures under any United Nations resolutions and/or under any laws, regulations, decrees, ordinances, orders, demands, requests, rules or requirements of EU, United Kingdom, and/or United States of America and which relate to foreign trade controls, export controls, embargoes or international boycotts (applying, without limitation, to the financing, payment, insurance, transportation, delivery or storage of product and/or services) hereinafter referred to as "Trade Sanctions".
- 8.2 Recurring the above circumstances during the performance of the contract, the Society shall be entitled at its sole and absolute discretion:
- (a) to immediately suspend payment or performance of the Services which are the object of the contract until such;
 - (b) time as the Trading Sanctions are in force;
 - (c) to a full disengagement from the obligation affected by the Trading Sanctions, in the event that the inability to fulfill the said obligation persists until the term provided for the fulfilment hereunder, provided that where the relevant obligation relates to payments for activities and/or Services which have already been delivered, the affected payment obligation shall remain only suspended until such time as the Trading Sanctions no longer apply to the payment ; and/or
 - (d) to terminate the contract, without prejudice of the Society's rights pursuant to Article 4.

ARTICLE 9

Should any part of these General Conditions be declared invalid, this will not affect the validity of the remaining provisions.

ARTICLE 10

When the Society provides its Services to a consumer - i.e. a natural person who does not act within the scope of his business or professional activity - the following provisions do not apply Article 3 (as far as the Society is solely entitled to the authentic interpretation of the Rules); Article 4, (as far as the payment of the fees is also due for Services not

concluded due to causes not attributable to the Interested Party); Article 5 (as far as the exclusion of liability is concerned), and Article 6 (as far as the jurisdiction of a Board of Arbitrators based in Abu Dhabi is concerned).

ARTICLE 11

- 11.1 The Society and the Interested Party shall promote safety, protect human health and environment and create safe working conditions for their personnel.
- 11.2 The Interested Party shall guarantee that the working environment in which the Society's Surveyor will be required to work is adequate, safe and in all respect compliant with the applicable legislation and Rules and shall adopt all necessary measures to mitigate and/or control any relevant risk.
- 11.3 Furthermore, in accordance with the applicable legislation and Rules, the Interested Party shall provide the Society with complete and detailed information relevant to any actual or potential specific risk existing in the work areas where the Surveyor will be required to operate and relevant to the performance of the Services as well as with any specific safety measure that the Society's Surveyor is requested to comply with.
- 11.4 The Society reserves not to commence and/or to suspend the Services and/or to terminate the contract, claiming compensation for any damage occurred, if it considers that the safety requirements listed in this Article are not satisfactorily met.

RULES FOR THE CLASSIFICATION OF
OFFSHORE UNITS OPERATING IN THE CASPIAN SEA
AND SIMILAR AREAS

Part C
Machinery, Systems and Fire Protection

Chapters **1** 2 3 4

Chapter 1	MACHINERY
Chapter 2	ELECTRICAL INSTALLATIONS
Chapter 3	AUTOMATION
Chapter 4	FIRE PROTECTION AND SAFETY SYSTEMS

CHAPTER 1 MACHINERY

Section 1 General Requirements

1	General	19
	1.1 Application	
	1.2 Additional requirements	
	1.3 Documentation to be submitted	
	1.4 Definitions	
2	Design and construction	20
	2.1 General	
	2.2 Materials, welding and testing	
	2.3 Vibrations	
	2.4 Operation in inclined position	
	2.5 Ambient conditions	
	2.6 Power of machinery	
	2.7 Astern power	
	2.8 Safety devices	
	2.9 Fuels	
	2.10 Use of asbestos	
3	Arrangement and installation on board	22
	3.1 General	
	3.2 Floors	
	3.3 Bolting down	
	3.4 Safety devices on moving parts	
	3.5 Gauges	
	3.6 Equipment located in the machinery space	
	3.7 Heating of spaces	
	3.8 Windows	
	3.9 Ventilation inlets	
	3.10 Ventilation in machinery spaces	
	3.11 Hot surfaces and fire protection	
	3.12 Special equipment	
	3.13 Communications	
	3.14 Machinery remote control, alarms and safety systems	
	3.15 Anti-icing	
	3.16 De-icing	
	3.17 Anti-freezing	
	3.18 Arrangements based on heating by fluids	
4	Tests and trials	25
	4.1 Works tests	
	4.2 Trials on board	

Section 2 Diesel Engines

1	General	26
	1.1 Application	
	1.2 Documentation to be submitted	
	1.3 Definitions	

2	Design and construction	29
	2.1 Materials and welding	
	2.2 Crankshaft	
	2.3 Crankcase	
	2.4 Scavenge manifolds	
	2.5 Systems	
	2.6 Starting air system	
	2.7 Control and monitoring	
3	Arrangement and installation	34
	3.1 Starting arrangements	
	3.2 Turning gear	
	3.3 Trays	
	3.4 Exhaust gas system	
4	Type tests, material tests, workshop inspection and testing, certification	37
	4.1 Type tests - General	
	4.2 Type tests of engines not admitted to an alternative inspection scheme	
	4.3 Type tests of engines admitted to an alternative inspection scheme	
	4.4 Material and non-destructive tests	
	4.5 Workshop inspections and testing	
	4.6 Certification	

Section 3 Boilers and Pressure Vessels

1	General	45
	1.1 Principles	
	1.2 Application	
	1.3 Definitions	
	1.4 Classes	
	1.5 Alternative standards	
	1.6 Documentation to be submitted	
2	Design and Construction - Principles	48
	2.1 Materials	
	2.2 Boilers and other steam generators	
	2.3 Boiler and steam generator safety valves	
	2.4 Pressure vessels	
	2.5 Thermal oil heaters and other pressure vessels associated with thermal oil installations	
	2.6 Special types of pressure vessels	
	2.7 Additional requirements for shell type exhaust gas economisers	
3	Design and construction - Scantlings	54
	3.1 General	
	3.2 Permissible stresses	
	3.3 Cylindrical, spherical and conical shells with circular cross-sections subject to internal pressure	
	3.4 Dished heads subject to pressure on the concave (internal) side	
	3.5 Flat heads	
	3.6 Nozzles	
	3.7 Water tube boilers	
	3.8 Additional requirements for vertical boilers and cylindrical boilers (fire tube boilers)	
	3.9 Bottles containing pressurised gases	
	3.10 Heat exchangers	

4	Design and construction - Fabrication and welding	76
4.1	General	
4.2	Welding design	
4.3	Miscellaneous requirements for fabrication and welding	
4.4	Preparation of parts to be welded	
4.5	Tolerances after construction	
4.6	Preheating	
4.7	Post-weld heat treatment	
4.8	Welding samples	
4.9	Specific requirements for class 1 vessels	
4.10	Specific requirements for class 2 vessels	
4.11	Specific requirements for Class 3 vessels	
5	Design and construction - Control and monitoring	89
5.1	Boiler control and monitoring system	
5.2	Pressure vessel instrumentation	
5.3	Thermal oil heater control and monitoring	
5.4	Control and monitoring	
6	Arrangement and installation	91
6.1	Foundations	
6.2	Boilers	
6.3	Pressure vessels	
6.4	Thermal oil heaters	
7	Material test, workshop inspection and testing, certification	93
7.1	Material testing	
7.2	Workshop inspections	
7.3	Hydrostatic tests	
7.4	Certification	

Section 4 Gearing

1	General	95
1.1	Application	
1.2	Documentation to be submitted	
2	Design of gears - Determination of the load capacity	96
2.1	Symbols, units, definitions	
2.2	Principle	
2.3	General influence factors	
2.4	Calculation of surface durability	
2.5	Calculation of tooth bending strength	
3	Design and construction - except tooth load capacity	103
3.1	Materials	
3.2	Teeth	
3.3	Wheels and pinions	
3.4	Shafts and bearings	
3.5	Casings	
3.6	Lubrication and clutch control	
3.7	Control and monitoring	
4	Installation	106
4.1	General	
4.2	Fitting of gears	

5	Certification, inspection and testing	106
5.1	General	
5.2	Workshop inspection and testing	

Section 5 Main Propulsion Shafting

1	General	108
1.1	Application	
1.2	Documentation to be submitted	
2	Design and construction	108
2.1	Materials	
2.2	Shafts - Scantling	
2.3	Liners	
2.4	Stern tube bearings	
2.5	Couplings	
2.6	Control and monitoring	
3	Arrangement and installation	115
3.1	General	
3.2	Protection of propeller shaft against corrosion	
3.3	Shaft alignment	
4	Material tests, workshop inspection and testing, certification	115
4.1	Material and non-destructive tests, workshop inspections and testing	
4.2	Certification	

Section 6 Propellers

1	General	117
1.1	Application	
1.2	Definitions	
1.3	Documentation to be submitted	
2	Design and construction	118
2.1		
2.2	Materials	
2.3	Solid propellers - Blade thickness	
2.4	Built-up propellers and controllable pitch propellers	
2.5	Skewed propellers	
2.6	Ducted propellers	
2.7	Features	
3	Arrangement and installation	121
3.1	Fitting of propeller on the propeller shaft	
4	Testing and certification	122
4.1	Material tests	
4.2	Testing and inspection	
4.3	Certification	

Section 7 Shaft Vibrations

1	General	125
	1.1 Application	
	1.2 Submission of documentation	
2	Design of systems in respect of vibrations	125
	2.1 Principle	
	2.2 Modifications of existing plants	
3	Torsional vibrations	125
	3.1 General	
	3.2 Documentation to be submitted	
	3.3 Definitions, symbols and units	
	3.4 Calculation principles	
	3.5 Permissible limits for torsional vibration stresses in crankshaft, propulsion shafting and other transmission shafting	
	3.6 Permissible vibration levels in components other than shafts	
	3.7 Torsional vibration measurements	
4	Lateral vibrations of main propulsion systems	129
	4.1 General	
	4.2 Calculations and measurements on board	
5	Axial vibrations of main propulsion systems	129
	5.1 General	
	5.2 Calculations and measurements on board	

Section 8 Piping Systems

1	General	130
	1.1 Application	
	1.2 Documentation to be submitted	
	1.3 Definitions	
	1.4 Symbols and units	
	1.5 Class of piping systems	
2	General requirements for design and construction	132
	2.1 Materials	
	2.2 Thickness of pressure piping	
	2.3 Calculation of high temperature pipes	
	2.4 Junction of pipes	
	2.5 Protection against overpressure	
	2.6 Flexible hoses and expansion joints	
	2.7 Valves and accessories	
	2.8 Sea inlets and overboard discharges	
	2.9 Control and monitoring	
3	Welding of steel piping	148
	3.1 Application	
	3.2 General	
	3.3 Design of welded joints	
	3.4 Preparation of elements to be welded and execution of welding	
	3.5 Post-weld heat treatment	
	3.6 Inspection of welded joints	

4	Bending of pipes	151
	4.1 Application	
	4.2 Bending process	
	4.3 Heat treatment after bending	
5	Arrangement and installation of piping systems	152
	5.1 General	
	5.2 Location of tanks and piping system components	
	5.3 Passage through watertight bulkheads or decks	
	5.4 Independence of lines	
	5.5 Prevention of progressive flooding	
	5.6 Provision for expansion	
	5.7 Supporting of the pipes	
	5.8 Protection of pipes	
	5.9 Valves, accessories and fittings	
	5.10 Additional arrangements for flammable fluids	
6	Bilge systems	155
	6.1 Application	
	6.2 Principle	
	6.3 Design of bilge systems	
	6.4 Draining of cargo spaces	
	6.5 Draining of machinery spaces	
	6.6 Draining of dry spaces other than cargo holds and machinery spaces	
	6.7 Bilge pumps	
	6.8 Size of bilge pipes	
	6.9 Bilge accessories	
	6.10 Materials	
	6.11 Bilge piping arrangement	
7	Ballast systems	160
	7.1 Design of ballast systems	
	7.2 Ballast pumping arrangement	
8	Scuppers and sanitary discharges	161
	8.1 Application	
	8.2 Principle	
	8.3 Drainage from spaces below the freeboard deck or within enclosed superstructures and deckhouses on the freeboard deck	
	8.4 Drainage of superstructures or deckhouses not fitted with efficient weathertight doors	
	8.5 Drainage of enclosed cargo spaces situated on the bulkhead deck or on the freeboard deck	
	8.6 Arrangement of discharges from spaces below the margin line	
	8.7 Arrangement of discharges from spaces above the margin line	
	8.8 Summary table of overboard discharge arrangements	
	8.9 Valves and pipes	
	8.10 Arrangement of scuppers and sanitary discharge piping	
9	Air, sounding and overflow pipes	165
	9.1 Air pipes	
	9.2 Sounding pipes	
	9.3 Overflow pipes	
	9.4 Constructional requirements applying to sounding, air and overflow pipes	
10	Cooling systems	170
	10.1 Application	
	10.2 Principle	

	10.3 Design of sea water cooling systems	
	10.4 Design of fresh water cooling systems	
	10.5 Design of oil cooling systems	
	10.6 Control and monitoring	
	10.7 Arrangement of cooling systems	
11	Fuel oil systems	172
	11.1 Application	
	11.2 Principle	
	11.3 General	
	11.4 Design of fuel oil filling and transfer systems	
	11.5 Arrangement of fuel oil tanks and bunkers	
	11.6 Design of fuel oil tanks and bunkers	
	11.7 Design of fuel oil heating systems	
	11.8 Design of fuel oil treatment systems	
	11.9 Design of fuel supply systems	
	11.10 Control and monitoring	
	11.11 Construction of fuel oil piping systems	
	11.12 Arrangement of fuel oil piping systems	
12	Lubricating oil systems	178
	12.1 Application	
	12.2 Principle	
	12.3 General	
	12.4 Design of engine lubricating oil systems	
	12.5 Design of lubricating oil tanks	
	12.6 Control and monitoring	
	12.7 Construction of lubricating oil piping systems	
13	Thermal oil systems	180
	13.1 Application	
	13.2 Principle	
	13.3 General	
	13.4 Design of thermal oil heaters and heat exchangers	
	13.5 Design of storage, expansion and draining tanks	
	13.6 Design of circulation and heat exchange systems	
	13.7 Control and monitoring	
	13.8 Construction of thermal oil piping systems	
	13.9 Thermal oil piping arrangements	
14	Hydraulic systems	183
	14.1 Application	
	14.2 Principle	
	14.3 General	
	14.4 Design of hydraulic systems	
	14.5 Design of hydraulic tanks and other components	
	14.6 Control and monitoring	
	14.7 Construction of hydraulic oil piping systems	
15	Steam systems	184
	15.1 Application	
	15.2 Principle	
	15.3 Design of steam lines	
16	Boiler feed water and condensate systems	185
	16.1 Application	
	16.2 Principle	
	16.3 Design of boiler feed water systems	

	16.4	Design of condensate systems	
	16.5	Control and monitoring	
	16.6	Arrangement of feed water and condensate piping	
17		Compressed air systems	187
	17.1	Application	
	17.2	Principle	
	17.3	Design of starting air systems	
	17.4	Design of control and monitoring air systems	
	17.5	Design of air compressors	
	17.6	Control and monitoring of compressed air systems	
	17.7	Materials	
	17.8	Arrangement of compressed air piping systems	
18		Exhaust gas systems	189
	18.1	General	
	18.2	Design of exhaust systems	
	18.3	Materials	
	18.4	Arrangement of exhaust piping systems	
19		Oxyacetylene welding systems	190
	19.1	Application	
	19.2	Definitions	
	19.3	Design of oxyacetylene welding systems	
	19.4	Arrangement of oxyacetylene welding systems	
20		Certification, inspection and testing of piping systems	192
	20.1	Application	
	20.2	Type tests	
	20.3	Testing of materials	
	20.4	Hydrostatic testing of piping systems and their components	
	20.5	Testing of piping system components during manufacturing	
	20.6	Inspection and testing of piping systems	

Section 9 Steering Gear

1		General	196
	1.1	Application	
	1.2	Documentation to be submitted	
	1.3	Definitions	
	1.4	Symbols	
2		Design and construction - Requirements applicable to all ships	198
	2.1	Mechanical components	
	2.2	Hydraulic system	
	2.3	Electrical systems	
	2.4	Alarms and indications	
3		Design and construction - Requirements for cargo ships of 500 tons gross tonnage or more	203
	3.1	Application	
	3.2	General	
	3.3	Strength, performance and power operation of the steering gear	
	3.4	Control of the steering gear	
	3.5	Availability	

4	Design and construction - Requirements for cargo ships of less than 500 tons gross tonnage	205
	4.1 Application	
	4.2 General	
	4.3 Strength, performance and power operation of the steering gear	
	4.4 Control of the steering gear	
	4.5 Availability	
5	Design and construction - Requirements for ships equipped with several rudders	206
	5.1 Principle	
	5.2 Synchronisation	
6	Design and construction - Requirements for ships equipped with thrusters as steering means	207
	6.1 Principle	
	6.2 Use of azimuth thrusters	
	6.3 Use of water-jets	
7	Arrangement and installation	207
	7.1 Steering gear room arrangement	
	7.2 Rudder actuator installation	
	7.3 Overload protections	
	7.4 Means of communication	
	7.5 Operating instructions	
8	Certification, inspection and testing	208
	8.1 Type tests of hydraulic pumps	
	8.2 Testing of materials	
	8.3 Inspection and tests during manufacturing	
	8.4 Inspection and tests after completion	

Section 10 Thrusters

1	General	209
	1.1 Application	
	1.2 Definitions	
	1.3 Thrusters intended for propulsion	
	1.4 Documentation to be submitted	
2	Design and Construction	209
	2.1 Materials	
	2.2 Transverse thrusters and azimuth thrusters	
	2.3 Water-jets	
	2.4 Alarm, monitoring and control systems	
3	Testing and certification	212
	3.1 Material tests	
	3.2 Testing and inspection	
	3.3 Certification	

Section 11 Refrigerating Installations

1	General	213
	1.1 Application	
2	Minimum design requirements	213
	2.1 Refrigerating installation components	
	2.2 Refrigerants	
	2.3 Special requirements for ammonia (R717)	

Section 12 Turbochargers

1	General	215
	1.1 Application	
	1.2 Documentation to be submitted	
2	Design and construction	215
	2.1 Monitoring	
3	Arrangement and installation	215
	3.1 General	
4	Type tests, material tests, workshop inspection and testing, certification	215
	4.1 Type tests	
	4.2 Identification of parts	
	4.3 Material tests	
	4.4 Workshop inspections and testing	
	4.5 Certification	

Section 13 Tests on Board

1	General	217
	1.1 Application	
	1.2 Purpose of shipboard tests	
	1.3 Documentation to be submitted	
2	General requirements for shipboard tests	217
	2.1 Trials at the moorings	
	2.2 Sea trials	
3	Shipboard tests for machinery	217
	3.1 Conditions of sea trials	
	3.2 Navigation and manoeuvring tests	
	3.3 Tests of boilers	
	3.4 Tests of diesel engines	
	3.5 Tests of electric propulsion system	
	3.6 Tests of gears	
	3.7 Tests of main propulsion shafting and propellers	
	3.8 Tests of piping systems	
	3.9 Tests of steering gear	
4	Inspection of machinery after sea trials	221
	4.1 General	
	4.2 Diesel engines	

Appendix 1 Check for Scantlings of Crankshafts for Diesel Engines

1	General	222
	1.1 Application	
	1.2 Documentation to be submitted	
	1.3 Principles of calculation	
2	Calculation of stresses	223
	2.1 Calculation of alternating stresses due to bending moments and radial forces	
	2.2 Calculation of alternating torsional stresses	
3	Evaluation of stress concentration factors	227
	3.1 General	
	3.2 Crankpin fillet	
	3.3 Journal fillet (not applicable to semi-built crankshafts)	
	3.4 Outlet of the crankpin oil bore	
4	Additional bending stresses	230
	4.1 General	
5	Calculation of equivalent alternating stress	230
	5.1 General	
	5.2 Equivalent alternating stress	
6	Calculation of fatigue strength	231
	6.1 General	
7	Acceptability criteria	231
	7.1 General	
8	Calculation of shrink-fits of semi-built crankshafts	231
	8.1 General	
	8.2 Maximum permissible hole in the journal pin	
	8.3 Necessary minimum oversize of shrink-fit	
	8.4 Maximum permissible oversize of shrink-fit	

Appendix 2 Plastic Pipes

1	General	235
	1.1 Application	
	1.2 Use of plastic pipes	
	1.3 Definitions	
2	Design of plastic piping systems	235
	2.1 General	
	2.2 Strength	
	2.3 Requirements depending on service and/or location	
	2.4 Pipe and fitting connections	
3	Arrangement and installation of plastic pipes	239
	3.1 General	
	3.2 Supporting of the pipes	
	3.3 Provision for expansion	
	3.4 External loads	
	3.5 Earthing	
	3.6 Penetration of fire divisions and watertight bulkheads or decks	

	3.7	Systems connected to the hull	
	3.8	Application of fire protection coatings	
4		Certification, inspection and testing of plastic piping	241
	4.1	Certification	
	4.2	Workshop tests	
	4.3	Testing after installation on board	

Appendix 3 Independent Fuel Oil Tanks

1		General	242
	1.1	Application	
	1.2	Documents to be submitted	
	1.3	Symbols and units	
2		Design and installation of tanks	242
	2.1	Materials	
	2.2	Scantling of steel tanks	
	2.3	Installation	

Appendix 4 Type Test Procedure for Crankcase Explosion Relief Valves

1		General	245
	1.1	Application	
	1.2	Recognised Standards	
	1.3	Purpose	
2		Test houses	245
	2.1	General	
3		Explosion tests, assessment and design series qualifications	246
	3.1	Process	
	3.2	Valves to be tested	
	3.3	Method	
	3.4	Assessment and records	
	3.5	Design series qualification	
4		Report and approval	248
	4.1	The test report	
	4.2	Approval	

Appendix 5 Type Test Procedure for Crankcase Oil Mist Detection and Alarm Equipment

1	General	249
	1.1 Application	
	1.2 Purpose	
2	Test houses	249
	2.1 General	
3	Tests	249
	3.1 Equipment testing	
	3.2 Functional test process	
	3.3 Detectors and alarm equipment to be tested	
	3.4 Method	
	3.5 Assessment	
	3.6 Design series qualification	
4	Report and approval	251
	4.1 Report	
	4.2 Approval	

Part C

Machinery , Systems and Fire Protection

Chapter 1

MACHINERY

SECTION 1	GENERAL REQUIREMENTS
SECTION 2	DIESEL ENGINES
SECTION 3	BOILERS AND PRESSURE VESSELS
SECTION 4	GEARING
SECTION 5	MAIN PROPULSION SHAFTING
SECTION 6	PROPELLERS
SECTION 7	SHAFT VIBRATIONS
SECTION 8	PIPING SYSTEMS
SECTION 9	STEERING GEAR
SECTION 10	THRUSTERS
SECTION 11	REFRIGERATING INSTALLATIONS
SECTION 12	TURBOCHARGERS
SECTION 13	TESTS ON BOARD
APPENDIX 1	CHECK FOR SCANTLINGS OF CRANKSHAFTS FOR DIESEL ENGINES
APPENDIX 2	PLASTIC PIPES
APPENDIX 3	INDEPENDENT FUEL OIL TANKS
APPENDIX 4	TYPE TEST PROCEDURE FOR CRANKCASE EXPLOSION RELIEF VALVES
APPENDIX 5	TYPE TEST PROCEDURE FOR CRANKCASE OIL MIST DETECTION AND ALARM EQUIPMENT

SECTION 1

GENERAL REQUIREMENTS

1 General

1.1 Application

1.1.1 Chapter 1 applies to the design, construction, installation, tests and trials of main propulsion and essential auxiliary machinery systems and associated equipment, boilers and pressure vessels, piping systems, and steering and manoeuvring systems installed on offshore units operating in the Caspian Sea and similar areas, as indicated in each Section of this Chapter.

1.2 Additional requirements

1.2.1 Additional requirements for machinery are given in:

- Part E, for the assignment of the service notations
- Part F, for the assignment of additional class notations.

1.3 Documentation to be submitted

1.3.1 Before the actual construction is commenced, the Manufacturer, Designer or Shipbuilder is to submit to the Society the documents (plans, diagrams, specifications and

calculations) requested in the relevant Sections of this Chapter.

The list of documents requested in each Section is to be intended as guidance for the complete set of information to be submitted, rather than an actual list of titles.

The Society reserves the right to request the submission of additional documents to those detailed in the Sections, in the case of non-conventional design or if it is deemed necessary for the evaluation of the system, equipment or component.

Plans are to include all the data necessary for their interpretation, verification and approval.

Unless otherwise stated in the other Sections of this Chapter or agreed with the Society, documents for approval are to be sent in triplicate if submitted by the Shipyard and in four copies if submitted by the equipment supplier. Documents requested for information are to be sent in duplicate.

In any case, the Society reserves the rights to require additional copies when deemed necessary.

1.3.2 Tab 1 lists the documents to be submitted for information or approval.

Table 1

No.	I/A (1)	Document
1	I	Manual for anti-icing precautions and de-icing procedures, including arrangement of anti-icing and de-icing equipment for the various areas (heating capacities are to be specified) and storage facilities and specification of hand tools for manual ice removing, protective clothing, lines, ect. to be carried onboard
2	A	Arrangement of the heat tracing systems based on: <ul style="list-style-type: none"> • fluid heating • electrical heating
3	A	De-icing arrangements of ballast tanks, sea chests
4	A	De-icing arrangements and protection for air intakes
5	A	Deck machinery arrangement (windlasses, winches and deck cranes)
6	A	Diagram of compressed air supply to important consumers outside machinery space
7	A	Diagrams of the steam, hot water, thermal oil piping or other systems used for de-icing purposes
8	A	De-icing devices distribution board
9	A	Test program for anti-icing and de-icing systems
10	A	Arrangement of the equipment located in the machinery spaces, refer to [3.6]
<p>(1) A : to be submitted for approval I : to be submitted for information.</p>		

1.4 Definitions

1.4.1 Machinery spaces of Category A

Machinery spaces of Category A are those spaces and trunks to such spaces which contain:

- internal combustion machinery used for main propulsion, or
- internal combustion machinery used for purposes other than main propulsion where such machinery has in the aggregate a total power output of not less than 375 kW, or
- any oil fired boiler or fuel oil unit, or
- gas generators, incinerators, waste disposal units, etc., which use oil fired equipment.

1.4.2 Machinery spaces

Machinery spaces are all machinery spaces of Category A and all other spaces containing propulsion machinery, boilers, fuel oil units, steam and internal combustion engines, generators and major electrical machinery, oil filling stations, refrigerating, stabilising, ventilation and air conditioning machinery, and similar spaces, and trunks to such spaces.

1.4.3 Fuel oil unit

Fuel oil unit is the equipment used for the preparation of fuel oil for delivery to an oil fired boiler, or equipment used for the preparation for delivery of heated oil to an internal combustion engine, and includes any oil pressure pumps, filters and heaters dealing with oil at a pressure of more than 0,18 N/mm².

For the purpose of this definition, inert gas generators are to be considered as oil fired boilers and gas turbines are to be considered as internal combustion engines.

1.4.4 Dead ship condition

Dead ship condition is the condition under which the whole propulsion system, including the main power supply, is not in operation and auxiliary means for bringing the main propulsion machinery into operation and for the restoration of the main power supply, such as compressed air and starting current from batteries, are not available, but assuming that means are available to start the emergency generator at all times.

2 Design and construction

2.1 General

2.1.1 The machinery, boilers and other pressure vessels, associated piping systems and fittings are to be of a design and construction adequate for the service for which they are intended and shall be so installed and protected as to reduce to a minimum any danger to persons on board, due regard being paid to moving parts, hot surfaces and other hazards.

The design is to have regard to materials used in construction, the purpose for which the equipment is intended, the working conditions to which it will be subjected and the environmental conditions on board.

2.2 Materials, welding and testing

2.2.1 General

Materials, welding and testing procedures are to be in accordance with the requirements of Part D and those given in the other Sections of this Chapter. In addition, for machinery components fabricated by welding the requirements given in [2.2.2] apply.

2.2.2 Welded machinery components

Welding processes and welders are to be approved by the Society in accordance with Part D, Chapter 5.

References to welding procedures adopted are to be clearly indicated on the plans submitted for approval.

Joints transmitting loads are to be either:

- full penetration butt-joints welded on both sides, except when an equivalent procedure is approved
- full penetration T- or cruciform joints.

For joints between plates having a difference in thickness greater than 3 mm, a taper having a length of not less than 4 times the difference in thickness is required. Depending on the type of stress to which the joint is subjected, a taper equal to three times the difference in thickness may be accepted.

T-joints on scalloped edges are not permitted.

Lap-joints and T-joints subjected to tensile stresses are to have a throat size of fillet welds equal to 0,7 times the thickness of the thinner plate on both sides.

In the case of welded structures including cast pieces, the latter are to be cast with appropriate extensions to permit connection, through butt-welded joints, to the surrounding structures, and to allow any radiographic and ultrasonic examinations to be easily carried out.

Where required, preheating and stress relieving treatments are to be performed according to the welding procedure specification.

2.3 Vibrations

2.3.1 Special consideration is to be given to the design, construction and installation of propulsion machinery systems and auxiliary machinery so that any mode of their vibrations shall not cause undue stresses in this machinery in the normal operating ranges.

2.4 Operation in inclined position

2.4.1

Main propulsion machinery and all auxiliary machinery essential to the propulsion and the safety of the ship are, as fitted in the ship, be designed to operate when the ship is upright and when inclined at any angle of list either way and trim by bow or stern as stated in Tab 2.

The Society may permit deviations from angles given in Tab 2, taking into consideration the type, size and service conditions of the ship.

Machinery with a horizontal rotation axis is generally to be fitted on board with such axis arranged alongships. If this is

not possible, the Manufacturer is to be informed at the time the machinery is ordered.

2.5 Ambient conditions

2.5.1 Machinery and systems covered by the Rules are to be designed to operate properly under the ambient conditions specified in Tab 3, unless otherwise specified in each Section of this Chapter.

2.6 Power of machinery

2.6.1 Unless otherwise stated in each Section of this Chapter, where scantlings of components are based on power, the values to be used are determined as follows:

- for main propulsion machinery, the power/rotational speed for which classification is requested
- for auxiliary machinery, the power/rotational speed which is available in service.

2.7 Astern power

2.7.1 Sufficient power for going astern is to be provided to secure proper control of the ship in all normal circumstances.

The main propulsion machinery is to be capable of maintaining in free route astern at least 70% of the maximum ahead revolutions for a period of at least 30 min.

Table 2 : Inclination of ship

Installations, components	Angle of inclination (degrees) (1)			
	Athwartship		Fore and aft	
	static	dynamic	static	dynamic
Main and auxiliary machinery	15	22,5	5 (4)	7,5
Safety equipment, e.g. emergency power installations, emergency fire pumps and their devices Switch gear, electrical and electronic appliances (3) and remote control systems	22,5 (2)	22,5 (2)	10	10

(1) Athwartship and fore-and-aft inclinations may occur simultaneously.
 (2) In ships for the carriage of liquefied gases and of chemicals the emergency power supply must also remain operable with the ship flooded to a final athwartship inclination up to a maximum of 30°.
 (3) Up to an angle of inclination of 45° no undesired switching operations or operational changes may occur.
 (4) Where the length of the ship exceeds 100m, the fore-and-aft static angle of inclination may be taken as 500/L degrees, where L is the length of ship, in metres, as defined in Pt B, Ch 1, Sec 2, [3.1.1].

Table 3 : Ambient conditions

AIR TEMPERATURE	
Location, arrangement	Temperature range (°C)
In enclosed spaces	between 0 and +45 (2)
On machinery components, boilers In spaces subject to higher or lower temperatures	According to specific local conditions
On exposed decks	between -35 and +45 (1)

WATER TEMPERATURE	
Coolant	Temperature (°C)
Sea water or, if applicable, sea water at charge air coolant inlet	between 0 and +32
(1) Electronic appliances are to be designed for an air temperature up to 55°C (for electronic appliances see also Chapter 2).	
(2) Different temperatures may be accepted by the Society in the case of ships intended for restricted service.	

For main propulsion systems with reversing gears, controllable pitch propellers or electrical propeller drive, running astern is not to lead to an overload of propulsion machinery.

During the sea trials, the ability of the main propulsion machinery to reverse the direction of thrust of the propeller is to be demonstrated and recorded (see also Sec 15).

2.8 Safety devices

2.8.1 Where risk from overspeeding of machinery exists, means are to be provided to ensure that the safe speed is not exceeded.

2.8.2 Where main or auxiliary machinery including pressure vessels or any parts of such machinery are subject to internal pressure and may be subject to dangerous overpressure, means shall be provided, where practicable, to protect against such excessive pressure.

2.8.3 Main turbine propulsion machinery and, where applicable, main internal combustion propulsion machinery and auxiliary machinery shall be provided with automatic shut-off arrangements in the case of failures, such as lubricating oil supply failure, which could lead rapidly to complete breakdown, serious damage or explosion.

The Society may permit provisions for overriding automatic shut-off devices.

See also the specific requirements given in the other Sections of this Chapter.

2.9 Fuels

2.9.1 Fuel oils employed for engines and boilers are, in general, to have a flash point (determined using the closed cup test) of not less than 60°C. However, for engines driving emergency generators, fuel oils having a flash point of less than 60°C but not less than 43°C are acceptable.

The use of fuel oil having a flashpoint of less than 60° C but not less than 43° C may be permitted (e.g. for feeding the emergency fire pump's engines and auxiliary machines which are not located in category A machinery spaces):

- a) for cargo ships of less than 500 gross tonnage or of 500 gross tonnage and upwards not engaged in international voyages or
- b) subject to the following:
 - fuel oil tanks except those arranged in double bottom compartments are located outside of category A machinery spaces;
 - provisions for the measurement of oil temperature are provided on the suction pipe of the fuel oil pump;
 - stop valves and/or cocks are provided on the inlet side and outlet side of the fuel oil strainers; and
 - pipe joints of welded construction or of circular cone type or spherical type union joint are applied as far as possible.

Fuel oil having flash points of less than 43°C may be employed on board cargo ships provided that it is stored outside machinery spaces and the arrangements adopted are specially approved by the Society.

2.10 Use of asbestos

2.10.1 New installation of materials which contain asbestos is prohibited.

3 Arrangement and installation on board

3.1 General

3.1.1 Provision shall be made to facilitate cleaning, inspection and maintenance of main propulsion and auxiliary machinery, including boilers and pressure vessels.

Easy access to the various parts of the propulsion machinery is to be provided by means of metallic ladders and gratings fitted with strong and safe handrails.

Spaces containing main and auxiliary machinery are to be provided with adequate lighting and ventilation.

3.2 Floors

3.2.1 Floors in engine rooms are to be metallic, divided into easily removable panels.

3.3 Bolting down

3.3.1 Bedplates of machinery are to be securely fixed to the supporting structures by means of foundation bolts which are to be distributed as evenly as practicable and of a sufficient number and size so as to ensure a perfect fit.

Where the bedplates bear directly on the inner bottom plating, the bolts are to be fitted with suitable gaskets so as to ensure a tight fit and are to be arranged with their heads within the double bottom.

Continuous contact between bedplates and foundations along the bolting line is to be achieved by means of chocks of suitable thickness, carefully arranged to ensure a complete contact.

The same requirements apply to thrust block and shaft line bearing foundations.

Particular care is to be taken to obtain a perfect levelling and general alignment between the propulsion engines and their shafting (see Sec 5).

3.3.2 Chocking resins are to be type approved.

3.4 Safety devices on moving parts

3.4.1 Suitable protective devices are to be provided in way of moving parts (flywheels, couplings, etc.) in order to avoid injuries to personnel.

3.5 Gauges

3.5.1 All gauges are to be grouped, as far as possible, near each manoeuvring position; in any event, they are to be clearly visible.

3.6 Equipment located in the machinery space

3.6.1 The combustion air is to be brought directly to the main and auxiliary engines by means of dedicated ducts in order not to lower machinery spaces temperature.

Alternatively operational limitations might be imposed to the unit.

3.6.2 Additional volume of air receivers is to be provided unless the internal combustion engine Manufacturer states that the provision above is unnecessary.

3.7 Heating of spaces

3.7.1 Heating of machinery spaces is to be provided if thermal balance may lead to low temperatures inside the room.

3.7.2 Special provisions are to be provided for heating and insulation of crew accommodation.

3.8 Windows

3.8.1 Heated windows to prevent moisture formation and icing are to be provided on the bridge.

3.9 Ventilation inlets

3.9.1 Closing apparatus for ventilation inlets and outlets are to be designed and located to protect them from ice or snow accumulation that could interfere with the effective closure of such systems.

3.10 Ventilation in machinery spaces

3.10.1

Machinery spaces of category A are to be sufficiently ventilated so as to ensure that when machinery or boilers therein are operating at full power in all weather conditions, including heavy weather, an adequate supply of air is maintained to the spaces for the safety and comfort of personnel and the operation of the machinery.

Any other machinery space shall be adequately ventilated in relation to the purpose of that machinery space.

This sufficient amount of air is to be supplied through suitably protected openings arranged in such a way that they can be used in all weather conditions, including heavy weather, taking into account Regulation 17(3) and Regulation 19 of the 1966 Load Line Convention as amended by the Protocol of 1988.

Special attention is to be paid both to air delivery and extraction and to air distribution in the various spaces. The quantity and distribution of air are to be such as to satisfy machinery requirements for developing maximum continuous power.

The ventilation is to be so arranged as to prevent any accumulation of flammable gases or vapours.

3.11 Hot surfaces and fire protection

3.11.1 Surfaces, having temperature exceeding 60°C, with which the crew are likely to come into contact during operation are to be suitably protected or insulated.

Surfaces of machinery with temperatures above 220°C, e.g. steam, thermal oil and exhaust gas lines, silencers, exhaust gas boilers and turbochargers, are to be effectively insulated with non-combustible material or equivalently protected to prevent the ignition of combustible materials coming into contact with them. Where the insulation used for this purpose is oil absorbent or may permit the penetration of oil, the insulation is to be encased in steel sheathing or equivalent material.

The insulation of hot surfaces is to be of a type and so supported that it does not crack or deteriorate when subject to vibration.

Fire protection, detection and extinction is to comply with the requirements of Chapter 4.

3.12 Special equipment

3.12.1 Protective clothing, safety lines, hand tools, crampons for shoes and similar equipment for de-icing purposes

are to be kept onboard. The quantity of the equipment is to be sufficient for the assumed extent of manual de-icing.

The equipment for manual de-icing is to be kept in storage facilities and at locations protected from accretion of ice by covers or other anti-icing arrangements.

3.13 Communications

3.13.1 Appropriate means of communication shall be provided from the navigating bridge and the engine room to any other position from which the speed and direction of thrust of the propellers may be controlled.

At least two independent means are to be provided for communicating orders from the navigating bridge to the position in the machinery space or in the control room from which the speed and the direction of the thrust of the propellers are normally controlled; one of these is to be an engine room telegraph, which provides visual indication of the orders and responses both in the machinery space and on the navigating bridge, with audible alarm mismatch between order and response.

The second means for communicating orders is to be fed by an independent power supply and is to be independent of other means of communication.

Where the main propulsion system of the ship is controlled from the navigating bridge by a remote control system, the second means of communication may be the same bridge control system.

The engine room telegraph is required in any case, even if the remote control of the engine is foreseen, irrespective of whether the engine room is attended.

For ships assigned with a restricted navigation notation these requirements may be relaxed at the Society's discretion.

3.14 Machinery remote control, alarms and safety systems

3.14.1 For remote control systems of main propulsion machinery and essential auxiliary machinery and relevant alarms and safety systems, the requirements of Chapter 3 apply.

3.14.2 An engineers' alarm shall be provided to be operated from the engine control room or at the manoeuvring platform as appropriate, and shall be clearly audible in the engineers' accommodation.

3.15 Anti-icing

3.15.1 Anti-icing arrangement is an arrangement suitable to keep areas free from ice under the ice conditions specified, by means of heating or covering.

Anti-icing arrangement is to be provided with sufficient capacity to keep the equipment or areas free from ice at all times in the service areas and under icing conditions for

components that are essential for the ship safety and operation such as:

- navigation (including navigation lights where necessary)
- communication equipment (i.e. antenna)
- scanning equipment (radar)
- watchman location
- steering
- propulsion
- air pipe vent heads for tanks
- scuppers and drains
- anchoring
- emergency towing
- cargo systems and ancillary systems
- fire fighting system
- crew thermal protection
- life saving appliances (including launching devices, heating system of lifeboat engine, storage facilities for life-saving outfit)
- ship whistle / air horn
- access way to the bow
- escape exits including doors
- ventilation inlets to spaces where ventilation is essential for the safe operation of the ship
- scuppers and drains for heated decks and spaces
- stern roller.

3.16 De-icing

3.16.1 De-icing arrangements are means suitable to remove ice from areas or equipment under the ice conditions specified.

In addition to the below, other operational equipment may be required to have de-icing arrangements as found necessary.

De-icing arrangements are to be provided with sufficient capacity for removal of accreted ice under the icing conditions specified for equipment /areas such as:

- open deck
- gangways/stairways
- superstructures
- railings
- mooring
- outdoor piping
- winches not listed in item [1]
- deck lighting
- helicopter decks
- cargo deck area.

De-icing arrangements are to be achievable in a limited time (normally 4 to 6 hours), in safe condition for the crew.

The heating power capacity for anti-icing and de-icing arrangements are to be not less than:

- for open deck areas, helicopter decks, gangways, stairways, etc.: 300 W/m²
- for superstructures: 200 W/m²
- for railings with inside heating: 50 W/m
- for other areas the heating capacity will be considered on a case-by-case basis.

An alarm is to be given when the temperature is below 10°C for 5 hours to inform the crew that the de-icing system is to be put into operation.

3.17 Anti-freezing

3.17.1 Anti-freezing arrangements are arrangements suitable to avoid freezing of liquids under the ice conditions specified.

Anti-freezing arrangements are to be provided for:

- fresh water
- ballast
- fuel oil tanks
- piping systems
- fire extinguishing systems
- water pipes on decks or non-heated spaces
- hydraulic oil systems on decks or non-heated spaces
- life-boat equipment.

3.18 Arrangements based on heating by fluids

3.18.1 In case of heating by fluids, when calculating the required steam capacity of steam plants or thermal oil heaters, additional capacity is to be considered for anti-icing and de-icing arrangements applying heating by fluids in pipes, as follows taking:

- 100% of the power consumption for anti-icing and anti-freezing equipment and areas, and
- 50% of the power consumption for de-icing equipment and areas.

When heating is based on fluid heat transfer by means of pipes, special attention is to be paid to the heat transfer from the pipes to the parts to be heated. The pipes are to be adequately spaced in order to provide sufficient heating. The connection of the pipes is to be adequate in order to efficiently transmit the heat to the parts to be heated.

Valves relevant to specific areas or equipment are to be clearly marked with reference to the equipment or area to be heated, and open-closed position of the valves is to be indicated.

Pumps applied for anti-icing purposes are to be arranged with redundancy.

The piping systems for anti-icing and de-icing purposes are also to comply with the requirements in Pt C, Ch 1, Sec 8.

Due regard is to be paid to the piping arrangements to avoid that the heating fluid freezes.

4 Tests and trials

4.1 Works tests

4.1.1 Equipment and its components are subjected to works tests which are detailed in the relevant Sections of this Chapter and are to be witnessed by the Surveyor.

Where such tests cannot be performed in the workshop, the Society may allow them to be carried out on board, provided this is not judged to be in contrast either with the general characteristics of the machinery being tested or with particular features of the shipboard installation. In such cases, the Surveyor entrusted with the acceptance of machinery on board and the purchaser are to be informed

in advance and the tests are to be carried out in accordance with the provisions of Part D relative to incomplete tests.

All boilers, all parts of machinery, all steam, hydraulic, pneumatic and other systems and their associated fittings which are under internal pressure shall be subjected to appropriate tests including a pressure test before being put into service for the first time as detailed in the other Sections of this Chapter.

4.1.2 Anti-icing, de-icing and anti-freezing systems are to be adequately tested.

4.2 Trials on board

4.2.1 Trials on board of machinery are detailed in Sec 13.

SECTION 2

DIESEL ENGINES

1 General

1.1 Application

1.1.1 Diesel engines listed below are to be designed, constructed, installed, tested and certified in accordance with the requirements of this Section, under the supervision and to the satisfaction of the Society's Surveyors:

- a) main propulsion engines
- b) engines driving electrical generators and other auxiliaries essential for safety and navigation and cargo pumps in tankers, when they develop a power of 110 kW and over.

All other engines are to be designed and constructed according to sound marine practice, with the equipment required in [2.3.4], [2.5.2], [2.7.2] [2.7.3], [2.7.5] and [2.7.8] and delivered with the relevant works' certificate (see Pt D, Ch 1, Sec 1, [4.2.3]).

Engines intended for propulsion of lifeboats and compression ignition engines intended for propulsion of rescue boats are to comply with the relevant Rule requirements.

In addition to the requirements of this Section, those given in Sec 1 apply.

1.2 Documentation to be submitted

1.2.1 For each type of engine that is required to be approved according to a) and b) of [1.1.1], the Manufacturer is to submit to the Society the documents listed in Tab 1.

Plans listed under items [2] and [3] in Tab 1 are also to contain details of the lubricating oil sump in order to demonstrate compliance with Sec 1, [2.4].

Where considered necessary, the Society may request the submission of further documents, including details of evidence of existing type approval or proposals for a type testing program in accordance with [4.2] and [4.3].

Where changes are made to an engine type for which the documents listed in Tab 1 have already been examined or approved, the engine Manufacturer is to resubmit to the Society for consideration and approval only those documents concerning the engine parts which have undergone substantial changes.

If the engines are manufactured by a licensee, the licensee is to submit, for each engine type, a list of all the drawings specified in Tab 1, indicating for each drawing the relevant number and revision status from both licensor and licensee.

Where the licensee proposes design modifications to components, the associated documents are to be submitted by

the licensee to the Society for approval or for information purposes. In the case of significant modifications, the licensee is to provide the Society with a statement confirming the licensor's acceptance of the changes. In all cases, the licensee is to provide the Surveyor entrusted to carry out the testing, with a complete set of the documents specified in Tab 1.

1.3 Definitions

1.3.1 Engine type

In general, the type of an engine is defined by the following characteristics:

- the cylinder diameter
- the piston stroke
- the method of injection (direct or indirect injection)
- the kind of fuel (liquid, gaseous or dual-fuel)
- the working cycle (4-stroke, 2-stroke)
- the gas exchange (naturally aspirated or supercharged)
- the maximum continuous power per cylinder at the corresponding speed and/or brake mean effective pressure corresponding to the above-mentioned maximum continuous power
- the method of pressure charging (pulsating system or constant pressure system)
- the charging air cooling system (with or without inter-cooler, number of stages, etc.)
- cylinder arrangement (in-line or V-type).

1.3.2 Engine power

The maximum continuous power is the maximum power at ambient reference conditions [1.3.3] which the engine is capable of delivering continuously, at nominal maximum speed, in the period of time between two consecutive overhauls.

Power, speed and the period of time between two consecutive overhauls are to be stated by the Manufacturer and agreed by the Society.

The rated power is the maximum power at ambient reference conditions [1.3.3] which the engine is capable of delivering as set after works trials (fuel stop power) at the maximum speed allowed by the governor.

The rated power for engines driving electric generators is the nominal power, taken at the net of overload, at ambient reference conditions [1.3.3], which the engine is capable of delivering as set after the works trials [4.5].

Table 1 : Documentation to be submitted

No.	I/A/A* (1)	Document	Document details
1	I	Engine particulars as per the Society form "Particulars of diesel engines" or equivalent form	-
2	I	Engine transverse cross-section	Max inclination angles, oil surface lines, oil suction strum position
3	I	Engine longitudinal section	Max inclination angles, oil surface lines, oil suction strum position
4	I / A*	Bedplate and crankcase, cast or welded. For welded bedplates or crankcases, welding details and instructions	The weld procedure specification is to include design of welded joints, electrodes used, welding sequence, pre- and post-heat treatment, non-destructive examinations
5	I	Thrust bearing assembly (2)	-
6	I / A*	Thrust bearing bedplate, cast or welded. For welded bedplates or cranks, welding details and instructions (2)	The weld procedure specification is to include design of welded joints, electrodes used, welding sequence, pre- and post-heat treatment, non-destructive examinations
7	I / A*	Frame/framebox, cast or welded with welding details and instructions (3)	The weld procedure specification is to include design of welded joints, electrodes used, welding sequence, pre- and post-heat treatment, non-destructive examinations
8	I	Tie rod	-
9	I	Cylinder head, assembly	-
10	I	Cylinder liner	-
11	A	Crankshaft, details, for each cylinder number	-
12	A	Crankshaft, assembly, for each cylinder number	-
13	A	Thrust shaft or intermediate shaft (if integral with engine)	-
14	A	Shaft coupling bolts	-
15	I	Counterweights (if not integral with crankshaft), with associated fastening bolts	Bolt fastening instructions
16	I	Connecting rod	-
17	I	Connecting rod, assembly	Bolt fastening instructions
18	I	Crosshead, assembly (4)	-
19	I	Piston rod, assembly (4)	-
20	I	Piston, assembly	-
21	I	Camshaft drive, assembly	-
<p>(1) A = to be submitted for approval, in four copies A* = to be submitted for approval of materials and weld procedure specifications, in four copies I = to be submitted for information, in duplicate. Where two indications I / A are given, the first refers to cast design and the second to welded design.</p> <p>(2) To be submitted only if the thrust bearing is not integral with the engine and not integrated in the engine bedplate.</p> <p>(3) Only for one cylinder.</p> <p>(4) To be submitted only if sufficient details are not shown on the engine transverse and longitudinal cross-sections.</p> <p>(5) Dimensions and materials of pipes, capacity and head of pumps and compressors and any additional functional information are to be included. The layout of the entire system is also required, if this is part of the goods to be supplied by the engine Manufacturer.</p> <p>(6) Required only for engines with cylinder bore of 200 mm and above or crankcase gross volume of 0,6 m³ and above.</p> <p>(7) Operation and service manuals are to contain maintenance requirements (servicing and repair) including details of any special tools and gauges that are to be used with their fitting/settings together with any test requirements on completion of maintenance. Where the operation and service manuals identify special tools and gauges for maintenance purposes, refer to Sec 10, [2.4.5].</p> <p>(8) For comparison with Society requirements for material, NDT and pressure testing as applicable.</p>			

No.	I/A/A* (1)	Document	Document details
22	A (8)	Material specifications of main parts of engine, with detailed information on: non-destructive tests, and pressure tests	Information on non-destructive tests is required for items 4, 7, 8, 9, 10, 11, 14, 17, 20, including acceptable defects and repair procedures. Information on pressure tests is required for items 4, 7, 9, 10, 20 and for injection pumps and exhaust manifold
23	A	Arrangement of foundation (for main engines only)	-
24	A	Schematic layout or other equivalent documents for starting air system on the engine (5)	-
25	A	Schematic layout or other equivalent documents for fuel oil system on the engine (5)	-
26	A	Schematic layout or other equivalent documents for lubricating oil system on the engine (5)	-
27	A	Schematic layout or other equivalent documents for cooling water system on the engine (5)	-
28	A	Schematic diagram of engine control and safety system on the engine (5) (see also [2.7])	List, specification and layout of sensors, automatic controls and other control and safety devices
29	I	Failure Mode and Effect Analysis (FMEA) of the electronic control system	The failure mode and effects analysis (FMEA) to demonstrate that failure of an electronic control system will not result in the loss of essential services for the operation of the engine and that operation of the engine will not be lost or degraded beyond an acceptable performance criterion of the engine, where engines incorporate electronic control in systems as per 24 to 28.
30	I	Shielding and insulation of exhaust pipes, assembly	-
31	A	Shielding of high pressure fuel pipes, assembly (see also [2.5.2])	Recovery and leak detection devices
32	A	Crankcase explosion relief valves (6) (see also [2.3.4])	Volume of crankcase and other spaces (camshaft drive, scavenge, etc.)
33	I	Operation and service manuals (7)	-
34	A	Schematic layout or other equivalent documents of hydraulic system (for valve lift) on the engine	-
35	A	Type test program and type test report	-
36	A	High pressure parts for fuel oil injection system	Specification of pressure, pipe dimensions and materials

- (1) A = to be submitted for approval, in four copies
A* = to be submitted for approval of materials and weld procedure specifications, in four copies
I = to be submitted for information, in duplicate.
Where two indications I / A are given, the first refers to cast design and the second to welded design.
- (2) To be submitted only if the thrust bearing is not integral with the engine and not integrated in the engine bedplate.
- (3) Only for one cylinder.
- (4) To be submitted only if sufficient details are not shown on the engine transverse and longitudinal cross-sections.
- (5) Dimensions and materials of pipes, capacity and head of pumps and compressors and any additional functional information are to be included. The layout of the entire system is also required, if this is part of the goods to be supplied by the engine Manufacturer.
- (6) Required only for engines with cylinder bore of 200 mm and above or crankcase gross volume of 0,6 m³ and above.
- (7) Operation and service manuals are to contain maintenance requirements (servicing and repair) including details of any special tools and gauges that are to be used with their fitting/settings together with any test requirements on completion of maintenance. Where the operation and service manuals identify special tools and gauges for maintenance purposes, refer to Sec 10, [2.4.5].
- (8) For comparison with Society requirements for material, NDT and pressure testing as applicable.

1.3.3 Ambient reference conditions

The power of engines as per [1.1.1] (a) and (b) is to be referred to the following conditions:

- barometric pressure = 0,1 MPa
- relative humidity = 60%
- ambient air temperature = 45°C
- sea water temperature (and temperature at inlet of sea water cooled charge air cooler) = 32°C.

In the case of ships assigned with a navigation notation other than unrestricted navigation, different temperatures may be accepted by the Society.

The engine Manufacturer is not expected to provide the above ambient conditions at a test bed. The rating is to be adjusted according to a recognised standard accepted by the Society.

1.3.4 Same type of engines

Two diesel engines are considered to be of the same type when they do not substantially differ in design and construction characteristics, such as those listed in the engine type definition as per [1.3.1], it being taken for granted that the documentation concerning the essential engine components listed in [1.2] and associated materials employed has been submitted, examined and, where necessary, approved by the Society.

2 Design and construction

2.1 Materials and welding

2.1.1 Crankshaft materials

In general, crankshafts are to be of forged steel having a tensile strength not less than 400 N/mm² and not greater than 1000 N/mm².

The use of forged steels of higher tensile strength is subject to special consideration by the Society in each case.

The Society, at its discretion and subject to special conditions (such as restrictions in ship navigation), may accept crankshafts made of cast carbon steel, cast alloyed steel or spheroidal or nodular graphite cast iron of appropriate quality and manufactured by a suitable procedure having a tensile strength as follows:

- between 400 N/mm² and 560 N/mm² for cast carbon steel
- between 400 N/mm² and 700 N/mm² for cast alloyed steel.

The acceptable values of tensile strength for spheroidal or nodular graphite cast iron will be considered by the Society on a case by case basis.

2.1.2 Welded frames and foundations

Steels used in the fabrication of welded frames and bed-plates are to comply with the requirements of Part D.

Welding is to be in accordance with the requirements of Sec 1, [2.2].

2.2 Crankshaft

2.2.1 Check of the scantling

The check of crankshaft strength is to be carried out in accordance with App 1.

2.3 Crankcase

2.3.1 Strength

Crankcase construction and crankcase doors are to be of sufficient strength to withstand anticipated crankcase pressures that may arise during a crankcase explosion taking into account the installation of explosion relief valves required in [2.3.4]. Crankcase doors are to be fastened sufficiently securely for them not be readily displaced by a crankcase explosion.

2.3.2 Ventilation and drainage

Ventilation of the crankcase, or any arrangement which could produce a flow of external air within the crankcase, is in principle not permitted.

Where provided, crankcase ventilation pipes are to be as small as practicable to minimise the inrush of air after a crankcase explosion.

If forced extraction of the oil mist atmosphere gases from the crankcase is provided (for mist smoke detection purposes, for instance), the vacuum in the crankcase is not to exceed $2,5 \times 10^{-4}$ N/mm².

To avoid interconnection between crankcases and the possible spread of fire following an explosion, crankcase ventilation pipes and oil drain pipes for each engine are to be independent of any other engine.

Lubricating oil drain pipes from the engine sump to the drain tank are to be submerged at their outlet ends.

2.3.3 Warning notice

A warning notice is to be fitted either on the control stand or, preferably, on a crankcase door on each side of the engine.

This warning notice is to specify that, whenever overheating is suspected within the crankcase, the crankcase doors or sight holes are not to be opened before a reasonable time has elapsed, sufficient to permit adequate cooling after stopping the engine.

2.3.4 Relief valves

- Diesel engines of a cylinder diameter of 200 mm and above or a crankcase gross volume of 0,6 m³ and above are to be provided with crankcase explosion relief valves according to the requirements of this item [2.3.4].

The total volume of the stationary parts within the crankcase may be discounted in estimating the crankcase gross volume (rotating and reciprocating components are to be included in the gross volume).

- Relief valves are to be provided with lightweight spring-loaded valve discs or other quick-acting and self-closing devices to relieve a crankcase of pressure in the event of an internal explosion and to prevent the inrush of air thereafter.

The valve discs in relief valves are to be made of ductile material capable of withstanding the shock of contact with stoppers at the full open position.

Relief valves are to be designed and constructed to open quickly and be fully open at a pressure not greater than 0,02 N/mm².

The free area of each crankcase explosion relief valve is not to be less than 45 cm². The aggregate free area of the valves fitted on an engine is not to be less than 115 cm² per cubic metre of the crankcase gross volume.

Relief valves are to be provided with a flame arrester that permits flow for crankcase pressure relief and prevents passage of flame following a crankcase explosion.

Relief valves are to be type approved. Type testing is to be carried out in a configuration that represents the installation arrangements that will be used on an engine in accordance with App 5.

Where relief valves are provided with arrangements for shielding emissions from the valve following an explosion, the valve is to be type tested to demonstrate that the shielding does not adversely affect the operational effectiveness of the valve.

- c) Relief valves are to be provided with a copy of the Manufacturer's installation and maintenance manual that is pertinent to the size and type of valve being supplied for installation on a particular engine.

The manual is to contain the following information:

- 1) Description of valve with details of function and design limits
- 2) Copy of type test certification
- 3) Installation instructions
- 4) Maintenance in service instructions to include testing and renewal of any sealing arrangements
- 5) Actions required after a crankcase explosion.

A copy of the installation and maintenance manual required above is to be provided on board ship.

Plans showing details and arrangements of crankcase explosion relief valves are to be submitted for approval in accordance with Tab 1.

Valves are to be provided with suitable markings that include the following information:

- Name and address of Manufacturer
- Designation and size
- Month/Year of manufacture
- Approved installation orientation.

- d) Engines of a cylinder diameter of 200 mm and above, but not exceeding 250 mm, are to have at least one valve near each end; however, for engines with more than 8 crankthrows, an additional valve is to be fitted near the middle of the engine.

Engines of a cylinder diameter of 250 mm and above, but not exceeding 300 mm, are to have at least one valve in way of each alternate crankthrow, with a minimum of two valves.

Engines of a cylinder diameter exceeding 300 mm are to have at least one valve in way of each main crankthrow.

- e) Additional relief valves are to be fitted on separate spaces of the crankcase, such as gear or chain cases for camshaft or similar drives, when the gross volume of such spaces is 0,6 m³ or above.

Scavenge spaces in open connection to the cylinders are to be fitted with explosion relief valves.

2.3.5 Oil mist detection/monitoring arrangements

Oil mist detection arrangements (or engine bearing temperature monitors or equivalent devices) are required:

- for alarm and slowdown purposes for low speed diesel engines of 2250 kW and above or having cylinders of more than 300 mm bore
- for alarm and automatic shut-off purposes for medium and high speed diesel engines of 2250 kW and above or having cylinders of more than 300 mm bore.

Oil mist detection arrangements are to be of a type approved by the Society and tested in accordance with App. 6 and are to comply with the requirements indicated hereinafter.

Engine bearing temperature monitors or equivalent devices used as safety devices are to be of a type approved by classification societies for such purposes.

Equivalent devices mean measures applied to high speed engines where specific design features are incorporated to preclude the risk of crankcase explosions.

The oil mist detection system and arrangements are to be installed in accordance with the engine Designer's and oil mist Manufacturer's instructions/recommendations. The following particulars are to be included in the instructions:

- Schematic layout of engine oil mist detection and alarm system showing location of engine crankcase sample points and piping or cable arrangements together with pipe dimensions to detector
- Evidence of study to justify the selected location of sample points and sample extraction rate (if applicable) in consideration of the crankcase arrangements and geometry and the predicted crankcase atmosphere where oil mist can accumulate
- The Manufacturer's maintenance and test manual
- Information relating to type or in-service testing of the engine carried out with engine protection system test arrangements having approved types of oil mist detection equipment.

A copy of the oil mist detection equipment maintenance and test manual required above is to be provided on board ship.

Oil mist detection and alarm information is to be capable of being read from a safe location away from the engine.

Each engine is to be provided with its own independent oil mist detection arrangement and a dedicated alarm.

Oil mist detection and alarm systems are to be capable of being tested on the test bed and on board under engine at standstill and engine running at normal operating conditions in accordance with test procedures that are acceptable to the Society.

Alarms and shutdowns for the oil mist detection/monitoring system are to be in accordance with Pt F, Ch 3, Sec 1,

Tab 2, Pt F, Ch 3, Sec 1, Tab 3 and Pt F, Ch 3, Sec 1, Tab 27 and the system arrangements are to comply with Ch 3, Sec 2, [6] and Ch 3, Sec 2, [7].

The oil mist detection arrangements are to provide an alarm indication in the event of a foreseeable functional failure in the equipment and installation arrangements.

The oil mist detection system is to provide an indication that any lenses fitted in the equipment and used in determination of the oil mist level have been partially obscured to a degree that will affect the reliability of the information and alarm indication.

Where oil mist detection equipment includes the use of programmable electronic systems, the arrangements are to be in accordance with Chapter 3.

Plans showing details and arrangements of oil mist detection arrangements are to be submitted for approval in accordance with Tab 1.

The equipment together with detectors is to be tested when installed on the test bed and on board ship to demonstrate that the detection and alarm system functionally operates. The testing arrangements are to be to the satisfaction of the Society.

Where sequential oil mist detection arrangements are provided, the sampling frequency and time are to be as short as reasonably practicable.

Where alternative methods are provided for the prevention of the build-up of potentially explosive oil mist conditions within the crankcase, details are to be submitted for consideration. The following information is to be included in the details to be submitted for consideration:

- Engine particulars - type, power, speed, stroke, bore and crankcase volume
- Details of arrangements to prevent the build-up of potentially explosive conditions within the crankcase, e.g. bearing temperature monitoring, oil splash temperature, crankcase pressure monitoring, recirculation arrangements
- Evidence to demonstrate that the arrangements are effective in preventing the build-up of potentially explosive conditions together with details of in-service experience
- Operating instructions and the maintenance and test instructions.

Where it is proposed to use the introduction of inert gas into the crankcase to minimise a potential crankcase explosion, details of the arrangements are to be submitted to the Society for consideration.

2.4 Scavenge manifolds

2.4.1 Fire extinguishing

For two-stroke crosshead type engines, scavenge spaces in open connection (without valves) to the cylinders are to be connected to a fixed fire-extinguishing system, which is to be entirely independent of the fire-extinguishing system of the machinery space.

2.4.2 Blowers

Where a single two-stroke propulsion engine is equipped with an independently driven blower, alternative means to drive the blower or an auxiliary blower are to be provided ready for use.

2.4.3 Relief valves

Scavenge spaces in open connection to the cylinders are to be fitted with explosion relief valves in accordance with [2.3.4].

2.5 Systems

2.5.1 General

In addition to the requirements of the present sub-article, those given in Sec 10 are to be satisfied.

Flexible hoses in the fuel and lubricating oil system are to be limited to the minimum and are to be type approved.

Unless otherwise stated in Sec 10, propulsion engines are to be equipped with external connections for standby pumps for:

- fuel oil supply
- lubricating oil and cooling water circulation.

2.5.2 Fuel oil system

Relief valves discharging back to the suction of the pumps or other equivalent means are to be fitted on the delivery side of the pumps.

In fuel oil systems for propulsion machinery, filters are to be fitted and arranged so that an uninterrupted supply of filtered fuel oil is ensured during cleaning operations of the filter equipment, except when otherwise stated in Sec 10.

- a) All external high pressure fuel delivery lines between the high pressure fuel pumps and fuel injectors are to be protected with a shielded piping system capable of containing fuel from a high pressure line failure.

A shielded pipe incorporates an outer pipe into which the high pressure fuel pipe is placed forming a permanent assembly.

The shielded piping system is to include a means for collection of leakages and arrangements are to be provided for an alarm to be given in the event of a fuel line failure.

If flexible hoses are used for shielding purposes, these are to be approved by the Society.

When in fuel oil return piping the pulsation of pressure with peak to peak values exceeds 2 MPa, shielding of this piping is also required as above.

- b) For ships classed for restricted navigation, the requirements under a) may be relaxed at the Society's discretion.

2.5.3 Lubricating oil system

Efficient filters are to be fitted in the lubricating oil system when the oil is circulated under pressure.

In such lubricating oil systems for propulsion machinery, filters are to be arranged so that an uninterrupted supply of filtered lubricating oil is ensured during cleaning operations of the filter equipment, except when otherwise stated in Sec 10.

Relief valves discharging back to the suction of the pumps or other equivalent means are to be fitted on the delivery side of the pumps.

The relief valves may be omitted provided that the filters can withstand the maximum pressure that the pump may develop.

Where necessary, the lubricating oil is to be cooled by means of suitable coolers.

2.5.4 Charge air system

- a) Requirements relevant to design, construction, arrangement, installation, tests and certification of exhaust gas turbochargers are given in Sec 14.
- b) When two-stroke propulsion engines are supercharged by exhaust gas turbochargers which operate on the impulse system, provision is to be made to prevent broken piston rings entering turbocharger casings and causing damage to blades and nozzle rings.

2.6 Starting air system

2.6.1 The requirements given in [3.1] apply.

2.7 Control and monitoring

2.7.1 General

In addition to those of this item [2.7], the general requirements given in Chapter 3 apply.

In the case of ships with automation notations, the requirements in Part F, Chapter 3 also apply.

2.7.2 Alarm

The lubricating oil system of diesel engines with a power equal to or in excess of 37 kW is to be fitted with alarms to give audible and visual warning in the event of an appreciable reduction in pressure of the lubricating oil supply.

2.7.3 Governors of main and auxiliary engines

Each engine, except the auxiliary engines for driving electric generators for which [2.7.5] applies, is to be fitted with a speed governor so adjusted that the engine does not exceed the rated speed by more than 15%.

2.7.4 Overspeed protective devices of main and auxiliary engines

In addition to the speed governor, each

- main propulsion engine having a rated power of 220kW and above, which can be declutched or which drives a controllable pitch propeller, and
- auxiliary engine having a rated power of 220kW and above, except those for driving electric generators, for which [2.7.6] applies

is to be fitted with a separate overspeed protective device so adjusted that the engine cannot exceed the rated speed n by

more than 20%; arrangements are to be made to test the overspeed protective device.

Equivalent arrangements may be accepted subject to special consideration by the Society in each case.

The overspeed protective device, including its driving mechanism or speed sensor, is to be independent of the governor.

2.7.5 Governors for auxiliary engines driving electric generators

- a) Auxiliary engines intended for driving electric generators are to be fitted with a speed governor which prevents transient frequency variations in the electrical network in excess of $\pm 10\%$ of the rated frequency with a recovery time to steady state conditions not exceeding 5 seconds, when the maximum electrical step load is switched on or off.

When a step load equivalent to the rated output of a generator is switched off, a transient speed variation in excess of 10% of the rated speed may be acceptable, provided this does not cause the intervention of the overspeed device as required by [2.7.4].

- b) At all loads between no load and rated power, the permanent speed variation is not to be more than 5% of the rated speed.
- c) Prime movers are to be selected in such a way that they meet the load demand within the ship's mains and, when running at no load, can satisfy the requirement in item a) above if suddenly loaded to 50% of the rated power of the generator, followed by the remaining 50% after an interval sufficient to restore speed to steady state. Steady state conditions (see Note 1) are to be achieved in not more than 5 s.

Note 1: Steady state conditions are those at which the envelope of speed variation does not exceed $\pm 1\%$ of the declared speed at the new power.

- d) Application of the the electrical load in more than 2 load steps can only be allowed if the conditions within the ship's mains permit the use of those auxiliary engines which can only be loaded in more than 2 load steps (see Fig 1 for guidance) and provided that this is already allowed for in the designing stage.

This is to be verified in the form of system specifications to be approved and to be demonstrated at ship's trials. In this case, due consideration is to be given to the power required for the electrical equipment to be automatically switched on after blackout and to the sequence in which it is connected

This also applies to generators to be operated in parallel and where the power is to be transferred from one generator to another, in the event that any one generator is to be switched off.

- e) Emergency generator sets must satisfy the governor conditions as per items a) and b), even when:
 - 1) their total consumer load is applied suddenly, or

2) their total consumer load is applied in steps, provided that:

- the total load is supplied within 45 seconds of power failure on the main switchboard, and
- the maximum step load is declared and demonstrated, and
- the power distribution system is designed such that the declared maximum step loading is not exceeded, and
- compliance of time delays and loading sequence with the above is demonstrated at ship's trials.

f) For alternating current generating sets operating in parallel, the governing characteristics of the prime movers are to be such that, within the limits of 20% and 100% total load, the load on any generating set will not normally differ from its proportionate share of the total load by more than 15% of the rated power in kW of the largest machine or 25% of the rated power in kW of the individual machine in question, whichever is the lesser.

For alternating current generating sets intended to operate in parallel, facilities are to be provided to adjust the governor sufficiently finely to permit an adjustment of load not exceeding 5% of the rated load at normal frequency.

2.7.6 Overspeed protective devices of auxiliary engines driving electric generators

In addition to the speed governor, auxiliary engines of rated power equal to or greater than 220 kW driving electric generators are to be fitted with a separate overspeed protective device, with a means for manual tripping, adjusted so as to prevent the rated speed from being exceeded by more than 15%.

This device is to automatically shut down the engine.

2.7.7 Use of electronic governors

a) Type approval

Electronic governors and their actuators are to be type approved by the Society, according to Ch 3, Sec 6.

b) Electronic governors for main propulsion engines

If an electronic governor is fitted to ensure continuous speed control or resumption of control after a fault, an additional separate governor is to be provided unless the engine has a manually operated fuel admission control system suitable for its control.

A fault in the governor system is not to lead to sudden major changes in propulsion power or direction of propeller rotation.

Alarms are to be fitted to indicate faults in the governor system.

The acceptance of electronic governors not in compliance with the above requirements will be considered by the Society on a case by case basis, when fitted on ships with two or more main propulsion engines.

c) Electronic governors for auxiliary engines driving electric generators

In the event of a fault in the electronic governor system the fuel admission is to be set to "zero".

Alarms are to be fitted to indicate faults in the governor system.

The acceptance of electronic governors fitted on engines driving emergency generators will be considered by the Society on a case by case basis.

2.7.8 Alarms and safeguards for emergency diesel engines

a) These requirements apply to diesel engines required to be immediately available in an emergency (i.e. emergency generating set engine, emergency fire pump engine, etc.) and capable of being controlled remotely or automatically operated.

b) Information demonstrating compliance with these requirements is to be submitted to the Society. The information is to include instructions to test the alarm and safety systems.

c) The alarms and safeguards are to be fitted in accordance with Tab 4.

d) The safety and alarm systems are to be designed to 'fail safe'. The characteristics of the 'fail safe' operation are to be evaluated on the basis not only of the system and its associated machinery, but also the complete installation, as well as the ship.

e) Regardless of the engine output, if shutdowns additional to those specified in Tab 4, except for the overspeed shutdown, are provided, they are to be automatically overridden when the engine is in automatic or remote control mode during navigation.

f) The alarm system is to function in accordance with Part F, Chapter 3 with the additional requirement that grouped alarms are to be arranged on the bridge.

g) In addition to the fuel oil control from outside the space, a local means of engine shutdown is to be provided.

h) Local indications of at least those parameters listed in Tab 4 to be provided within the same space as the diesel engines and are to remain operational in the event of failure of the alarm and safety systems.

2.7.9 Summary tables

Diesel engines are to be equipped with monitoring equipment as detailed in Tab 2 and Tab 3, for main propulsion and auxiliary services, respectively.

For ships classed for restricted navigation, the acceptance of a reduction in the monitoring equipment required in Tab 2 and Tab 3 may be considered.

The alarms are to be visual and audible.

The indicators are to be fitted at a normally attended position (on the engine or at the local control station).

In the case of diesel engines required to be immediately available in an emergency and capable of being controlled remotely or automatically operated, Tab 4 applies.

3 Arrangement and installation

3.1 Starting arrangements

3.1.1 Mechanical air starting (1/1/2023)

- a) Air starting the main and auxiliary engines is to be arranged such that the necessary air for the first charge can be produced on board the ship without external aid.
- b) The total capacity of air receivers is to be sufficient to provide, without replenishment, not less than 12 consecutive starts alternating between ahead and astern of each main engine of the reversible type, and not less than 6 consecutive starts of each main non-reversible type engine connected to a controllable pitch propeller or other device enabling the start without opposite torque.

When other users such as auxiliary engine starting systems, control systems, whistle etc. are connected to the starting air receivers of main propulsion engines, their air consumption is also to be taken into account.

Regardless of the above, for multi-engine installations the number of starts required for each engine may be reduced subject to the agreement of the Society and depending upon the arrangement of the engines and the transmission of their output to the propellers.

- c) The main starting air arrangements for main propulsion or auxiliary diesel engines are to be adequately protected against the effects of backfiring and internal explosion in the starting air pipes. To this end, the following safety devices are to be fitted:

- An isolating non-return valve, or equivalent, at the starting air supply connection to each engine.
- A bursting disc or flame arrester:
 - in way of the starting valve of each cylinder, for direct reversing engines having a main starting air manifold
 - at least at the supply inlet to the starting air manifold, for non-reversing engines.

The bursting disc or flame arrester above may be omitted for engines having a bore not exceeding 230 mm.

Other protective devices will be specially considered by the Society.

The requirements of this item c) do not apply to engines started by pneumatic motors.

- d) Compressed air receivers are to comply with the requirements of Sec 3. Compressed air piping and associated air compressors are to comply with the requirements of Sec 10.

Figure 1 : Limiting curves for loading 4-stroke diesel engines step by step from no load to rated power as a function of the brake mean effective pressure

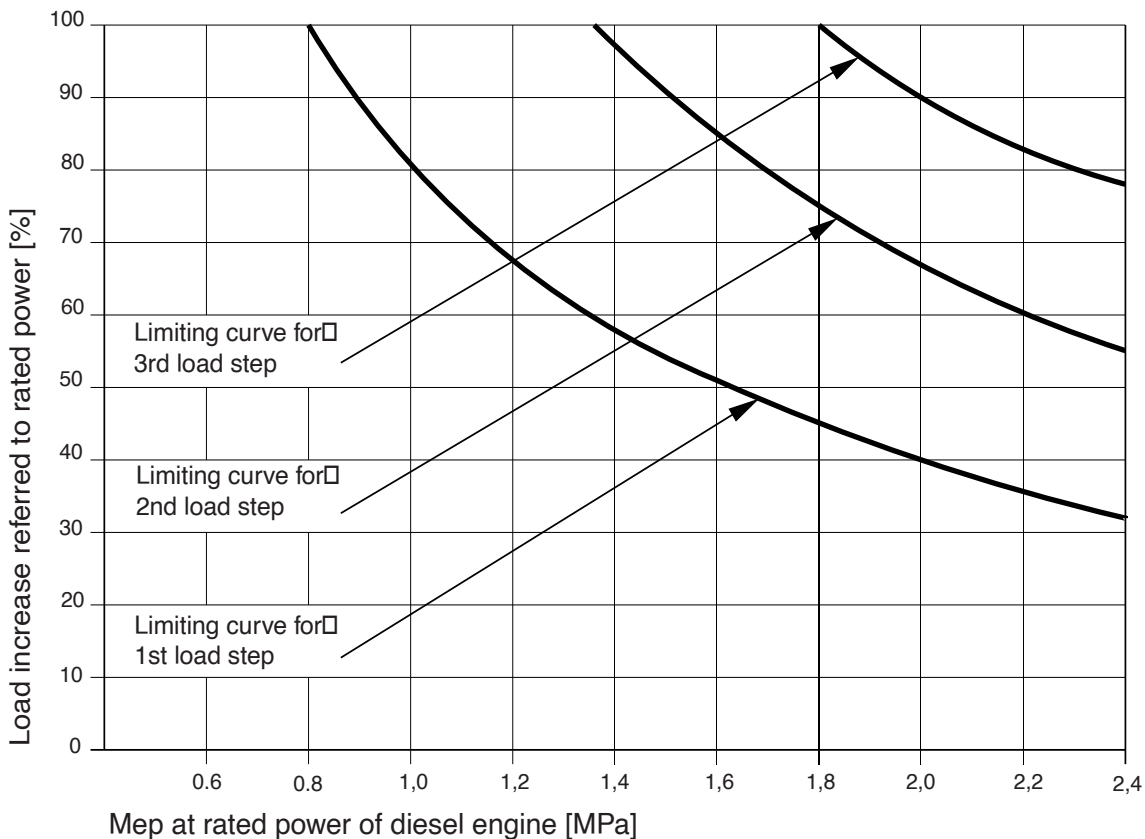

Table 2 : Monitoring of main propulsion diesel engines

Symbol convention H = High, HH = High high, G = group alarm L = Low, LL = Low low, I = individual alarm X = function is required, R = remote	Monitoring		Automatic control				
			Main Engine			Auxiliary	
Identification of system parameter	Alarm	Indica- tion	Slow- down	Shut- down	Control	Stand by Start	Stop
Fuel oil pressure after filter (engine inlet)		local					
Fuel oil viscosity before injection pumps or fuel oil temperature before injection pumps (For engine running on heavy fuel)		local					
Leakage from high pressure pipes where required	H						
Lubricating oil to main bearing and thrust bearing pressure	L	local					
	LL			X			
Lubricating oil to cross-head bearing pressure when separate	L	local					
	LL			X			
Lubricating oil to camshaft pressure when separate	L	local					
	LL			X			
Turbocharger lubricating oil inlet pressure		local					
Lubricating oil inlet temperature		local					
Thrust bearing pads or bearing outlet temperature	H	local					
Cylinder fresh cooling water system inlet pressure	L	local (3)					
Cylinder fresh cooling water outlet temperature or, when common cooling space without individual stop valves, the common cylinder water outlet temperature		local					
Piston coolant inlet pressure on each cylinder (1)	L	local					
Piston coolant outlet temperature on each cylinder (1)		local					
Piston coolant outlet flow on each cylinder (1) (2)	L						
Scavenging air receiver pressure		local					
Scavenging air box temperature (Detection of fire in receiver)		local					
Exhaust gas temperature		local (4)					
Engine speed / direction of speed (when reversible)		local					
	H			X			
Fault in the electronic governor system	X						
<p>(1) Not required, if the coolant is oil taken from the main cooling system of the engine</p> <p>(2) Where outlet flow cannot be monitored due to engine design, alternative arrangement may be accepted</p> <p>(3) For engines of 220 kW and above</p> <p>(4) Indication is required after each cylinder, for engines of 500 kW/cylinder and above</p>							

Table 3 : Monitoring of diesel engines used for auxiliary services

Symbol convention H = High, HH = High high, G = group alarm L = Low, LL = Low low, I = individual alarm X = function is required, R = remote	Monitoring		Automatic control				
			Engine			Auxiliary	
Identification of system parameter	Alarm	Indication	Slow-down	Shut-down	Control	Stand by Start	Stop
Fuel oil viscosity or temperature before injection (2)		local					
Fuel oil pressure (2)		local					
Fuel oil leakage from pressure pipes	H						
Lubricating oil pressure	L	local		X (1)			
Pressure or flow of cooling water, if not connected to main system	L	local					
Temperature of cooling water or cooling air		local					
Engine speed		local					
	H			X (3)			
Fault in the electronic governor system	X						
(1) Not acceptable to emergency generator set							
(2) Where heavy fuel is used							
(3) Only requested for diesel engines having rating of 220 kW and above							

Table 4 : Monitoring of diesel engines required to be immediately available in an emergency and capable of being controlled remotely or automatically operated

Symbol convention H = High, HH = High high, G = group alarm L = Low, LL = Low low, I = individual alarm X = function is required, R = remote	Monitoring		Automatic control				
			Engine			Auxiliary	
Identification of system parameter	Alarm	Indication	Slow-down	Shut-down	Control	Stand by Start	Stop
Fuel oil leakage from pressure pipes	H						
Lubricating oil pressure	L	local					
Lubricating oil temperature (1)	H	local					
Pressure or flow of cooling water (1)	L	local					
Oil mist concentration in crankcase (2)	H	local					
Temperature of cooling water or cooling air	H	local					
Engine speed		local					
	H (1)			X (1)			
Fault in the electronic governor system	X						
(1) Requested only for diesel engines having rating of 220 kW and above.							
(2) Requested only for diesel engines having rating of 2250 kW and above or cylinder bore of 300 mm and above							

3.1.2 Electrical starting

- a) Where main internal combustion engines are arranged for electrical starting, at least two separate batteries are to be fitted.

The arrangement is to be such that the batteries cannot be connected in parallel.

Each battery is to be capable of starting the main engine when in cold and ready to start condition.

The combined capacity of batteries is to be sufficient to provide within 30 min, without recharging, the number of starts required in [3.1.1] (b) in the event of air starting.

- b) Electrical starting arrangements for auxiliary engines are to have two separate storage batteries or may be supplied by two separate circuits from main engine storage

batteries when these are provided. In the case of a single auxiliary engine, one battery is acceptable. The combined capacity of the batteries is to be sufficient for at least three starts for each engine.

- c) The starting batteries are only to be used for starting and for the engine's alarm and monitoring. Provision is to be made to maintain the stored energy at all times.
- d) Each charging device is to have at least sufficient rating for recharging the required capacity of batteries within 6 hours.

3.1.3 Special requirements for starting arrangements for emergency generating sets

- a) Emergency generating sets are to be capable of being readily started in their cold condition at a temperature of 0°C. If this is impracticable, or if lower temperatures are likely to be encountered, provision acceptable to the Society shall be made for the maintenance of heating arrangements, to ensure ready starting of the generating sets.
- b) Each emergency generating set arranged to be automatically started shall be equipped with starting devices approved by the Society with a stored energy capability of at least three consecutive starts.

The source of stored energy shall be protected to preclude critical depletion by the automatic starting system, unless a second independent means of starting is provided. In addition, a second source of energy shall be provided for an additional three starts within 30 minutes, unless manual starting can be demonstrated to be effective.

- c) The stored energy is to be maintained at all times, as follows:
 - electrical and hydraulic starting systems shall be maintained from the emergency switchboard
 - compressed air starting systems may be maintained by the main or auxiliary compressed air receivers through a suitable non-return valve or by an emergency air compressor which, if electrically driven, is supplied from the emergency switchboard
 - all of these starting, charging and energy storing devices are to be located in the emergency generator space; these devices are not to be used for any purpose other than the operation of the emergency generating set. This does not preclude the supply to the air receiver of the emergency generating set from the main or auxiliary compressed air system through the non-return valve fitted in the emergency generator space.
- d) Where automatic starting is not required, manual starting, such as manual cranking, inertia starters, manually charged hydraulic accumulators, or powder charge cartridges, is permissible where this can be demonstrated as being effective.
- e) When manual starting is not practicable, the requirements of (b) and (c) are to be complied with, except that starting may be manually initiated.

3.2 Turning gear

3.2.1 Each engine is to be provided with hand-operated turning gear; where deemed necessary, the turning gear is to be both hand and mechanically-operated.

The turning gear engagement is to inhibit starting operations.

3.3 Trays

3.3.1 Trays fitted with means of drainage are to be provided in way of the lower part of the crankcase and, in general, in way of the parts of the engine, where oil is likely to spill in order to collect the fuel oil or lubricating oil dripping from the engine.

3.4 Exhaust gas system

3.4.1 In addition to the requirements given in Sec 10, the exhaust system is to be efficiently cooled or insulated in such a way that the surface temperature does not exceed 220°C (see also Sec 1, [3.11]).

4 Type tests, material tests, workshop inspection and testing, certification

4.1 Type tests - General

4.1.1 Upon finalisation of the engine design for production of every new engine type intended for installation on board ships, one engine is to be presented for type testing as required below.

A type test carried out for a particular type of engine at any place in any manufacturer's works will be accepted for all engines of the same type (see [1.3.4]) built by licensees and licensors.

In any case, one type test suffices for the whole range of engines having different numbers of cylinders.

Engines which are subjected to type testing are to be tested in accordance with the scope specified below, it being taken for granted that:

- the engine is optimised as required for the conditions of the type test
- the investigations and measurements required for reliable engine operation have been carried out during preliminary internal tests by the engine Manufacturer
- the documentation to be submitted as required in [1.2] has been examined and, when necessary, approved by the Society and the latter has been informed about the nature and extent of investigations carried out during pre-production stages.

4.1.2 At the request of the Manufacturer, an increase in power and/or mean effective pressure up to a maximum of 10% may be accepted by the Society for an engine previously subjected to a type test without any further such test being required, provided the engine reliability has been

proved successfully by the service experience of a sufficient number of engines of the same type.

For the purpose of the acceptance of the above performance increase, the Manufacturer is in any case to submit for examination and, where necessary, approval, the documentation listed in [1.2] relevant to any components requiring modification in order to achieve the increased performance.

4.1.3 If an electronically controlled diesel engine has been type tested as a conventional engine, the Society may waive the type tests required by the present item [4.1] provided the results of the individual tests in [4.5] are similar.

4.2 Type tests of engines not admitted to an alternative inspection scheme

4.2.1 General

Engines which are not admitted to testing and inspections according to an alternative inspection scheme (see Pt D, Ch 1, Sec 1, [3.2]) are to be type tested in the presence of a Surveyor in accordance with the requirements of this item [4.2].

The type test is subdivided into three stages, namely:

a) Stage A - Preliminary internal tests carried out by the Manufacturer.

Stage A includes functional tests and collection of operating values including the number of testing hours during the internal tests, the results of which are to be presented to the Surveyor during the type test. The number of testing hours of components which are inspected according to [4.2.5] is to be stated by the Manufacturer.

b) Stage B - Type approval test

The type approval test is to be carried out in the presence of the Surveyor.

c) Stage C - Inspection of main engine components.

After completion of the test programme, the main engine components are to be inspected.

The engine Manufacturer is to compile all results and measurements for the engine tested during the type test in a type test report, which is to be submitted to the Society.

If an electronically controlled diesel engine has been type tested as a conventional engine, the Society may waive tests required by this item [4.2] provided the results of the individual tests would be similar.

4.2.2 Stage A - Internal tests (function tests and collection of operating data)

During the internal tests the engine is to be operated at the load points considered important by the engine Manufacturer and the relevant operating values are to be recorded (see item (a)).

The load points may be selected according to the range of application (see Fig 2).

If an engine can be satisfactorily operated at all load points without using mechanically driven cylinder lubricators, this is to be verified.

For engines which may operate on heavy fuel oil, their suitability for this is to be proved to the satisfaction of the Society.

a) Functional tests under normal operating conditions

Functional tests under normal operating conditions include:

1) The load points 25%, 50%, 75%, 100% and 110% of the maximum continuous power for which type approval is requested, to be carried out:

- along the nominal (theoretical) propeller curve and at constant speed, for propulsion engines
- at constant speed, for engines intended for generating sets.

2) The limit points of the permissible operating range.

These limit points are to be defined by the engine Manufacturer.

The maximum continuous power P is defined in [1.3.2].

b) Tests under emergency operating conditions

For turbocharged engines, the achievable continuous output is to be determined for a situation when one turbocharger is damaged, i.e.:

- for engines with one turbocharger, when the rotor is blocked or removed;
- for engines with two or more turbochargers, when the damaged turbocharger is shut off.

4.2.3 Stage B - Type approval tests in the presence of the Surveyor

During the type test, the tests listed below are to be carried out in the presence of the Surveyor and the results are to be recorded in a report signed by both the engine Manufacturer and the Surveyor.

Any departures from this programme are to be agreed upon by the engine Manufacturer and the Society.

a) Load points

The load points at which the engine is to be operated according to the power/speed diagram (see Fig 2) are those listed below. The data to be measured and recorded when testing the engine at various load points are to include all necessary parameters for engine operation.

The operating time per load point depends on the engine characteristics (achievement of steady-state condition) and the time for collection of the operating values.

Normally, an operating time of 0,5 hour per load point can be assumed.

At the maximum continuous power as per the following item (1) an operating time of two hours is required. Two

sets of readings are to be taken at a minimum interval of one hour.

- 1) Test at maximum continuous power P: i.e. 100% output at 100% torque and 100% speed, corresponding to load point 1 in the diagram in Fig 2.
- 2) Test at 100% power at maximum permissible speed, corresponding to load point 2 in the diagram in Fig 2.
- 3) Test at maximum permissible torque (normally 110% of nominal torque T) at 100% speed, corresponding to load point 3 in the diagram in Fig 2; or test at maximum permissible power (normally 110% of P) and speed according to the nominal propeller curve, corresponding to load point 3a in the diagram in Fig 2.
- 4) Test at minimum permissible speed at 100% of torque T, corresponding to load point 4 in the diagram in Fig 2.
- 5) Test at minimum permissible speed at 90% of torque T, corresponding to load point 5 in the diagram in Fig 2.
- 6) Tests at part loads, e.g. 75%, 50%, 25% of maximum continuous power P and speed according to the nominal propeller curve, corresponding to load points 6, 7 and 8 in the diagram in Fig 2; and tests at the above part loads and at speed n with constant governor setting, corresponding to load points 9, 10 and 11 in the diagram in Fig 2.

b) Tests under emergency operating conditions

These are tests at maximum achievable power when operating along the nominal propeller curve and when operating with constant governor setting for speed n, in emergency operating conditions as stated in [4.2.2] (b).

c) Additional tests

- Test at lowest engine speed according to the nominal propeller curve.
- Starting tests for non-reversible engines, or starting and reversing tests for reversible engines.
- Governor tests.
- Testing of the safety system, particularly for over-speed and low lubricating oil pressure.
- Integration tests, for electronically controlled diesel engines, to verify that the response of the complete mechanical, hydraulic and electronic system is as predicted for all intended operational modes. The scope of these tests is to be agreed with the Society for selected cases based on the FMEA required in Tab 1.

For engines intended to be used for emergency services, supplementary tests may be required to the satisfaction of the Society. In particular, for engines intended to drive emergency generating sets, additional tests and/or documents may be required to prove that the engine is capable of being readily started at a temperature of 0°C.

Figure 2 : Power/speed diagram

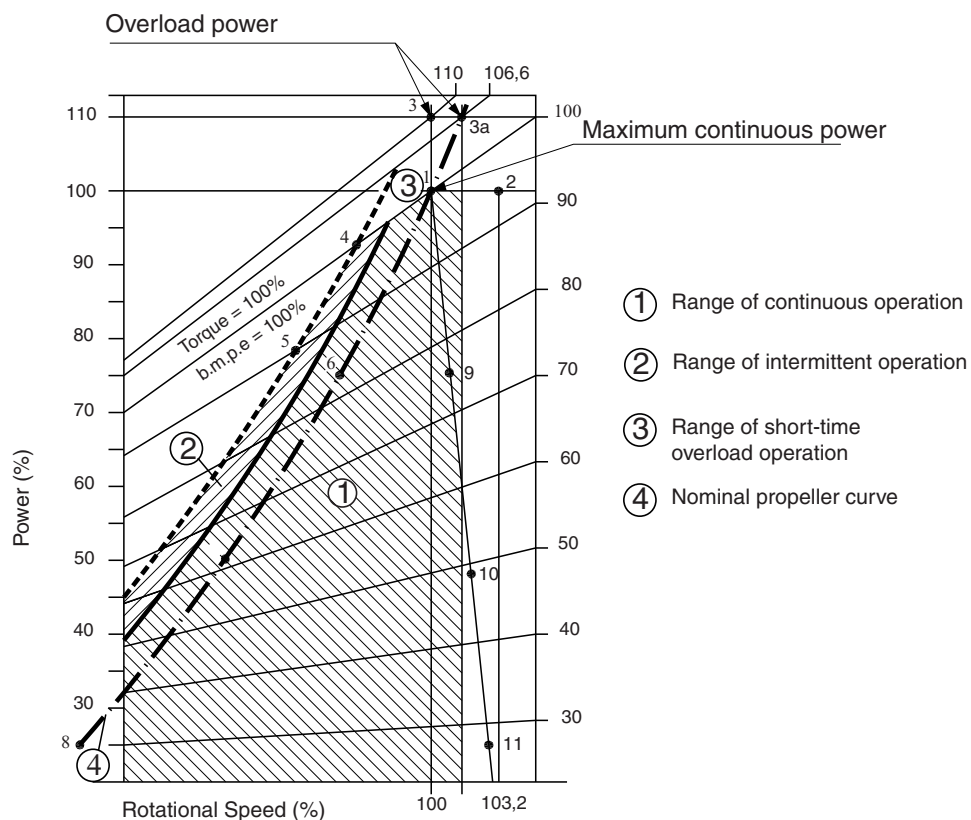

4.2.4 Evaluation of test results

The results of the tests and checks required by [4.2.3] will be evaluated by the attending Surveyor. Normally the main operating data to be recorded during the tests are those listed in [4.3.4].

In particular, the maximum combustion pressure measured with the engine running at the maximum continuous power P is not to exceed the value taken for the purpose of checking the scantlings of the engine crankshaft, according to the applicable requirements of Chapter 1, Appendix 1.

The values of temperatures and pressures of media, such as cooling water, lubricating oil, charge air, exhaust gases, etc., are to be within limits which, in the opinion of the Surveyor, are appropriate for the characteristics of the engine tested.

4.2.5 Stage C - Inspection of main engine components

Immediately after the test run as per [4.2.3], the components of one cylinder for in-line engines, and two cylinders for V-type engines, are to be presented for inspection to the Surveyor.

The following main engine components are to be inspected:

- piston removed and dismantled
- crosshead bearing, dismantled
- crank bearing and main bearing, dismantled
- cylinder liner in the installed condition
- cylinder head and valves, disassembled
- control gear, camshaft and crankcase with opened covers.

Where deemed necessary by the Surveyor, further dismantling of the engine may be required.

4.3 Type tests of engines admitted to an alternative inspection scheme

4.3.1 General

Engines for which the Manufacturer is admitted to testing and inspections according to an alternative inspection scheme (see Pt D, Ch 1, Sec 1, [3.2]) and which have a cylinder bore not exceeding 300 mm are to be type tested in the presence of a Surveyor in accordance with the requirements of this item [4.3].

The selection of the engine to be tested from the production line is to be agreed upon with the Surveyor.

4.3.2 Type test

The programme of the type test is to be in general as specified below, P being the maximum continuous power and n the corresponding speed. The maximum continuous power is that stated by the engine Manufacturer and accepted by the Society, as defined in [1.3.2].

- a) 80 hours at power P and speed n
- b) 8 hours at overload power (110% of power P)
- c) 10 hours at partial loads (25%, 50%, 75% and 90% of power P)
- d) 2 hours at intermittent loads
- e) starting tests

- f) reverse running for direct reversing engines
- g) testing of speed governor, overspeed device and lubricating oil system failure alarm device;
- h) testing of the engine with one turbocharger out of action, when applicable
- i) testing of the minimum speed along the nominal (theoretical) propeller curve, for main propulsion engines driving fixed pitch propellers, and of the minimum speed with no brake load, for main propulsion engines driving controllable pitch propellers or for auxiliary engines.

The tests at the above-mentioned outputs are to be combined together in working cycles which are to be repeated in succession for the entire duration within the limits indicated.

In particular, the overload test, to be carried out at the end of each cycle, is to be of one hour's duration and is to be carried out alternately:

- at 110% of the power P and 103% of the speed n
- at 110% of the power P and 100% of the speed n.

The partial load tests specified in (c) are to be carried out:

- along the nominal (theoretical) propeller curve and at constant speed, for propulsion engines
- at constant speed, for engines intended for generating sets.

For engines intended to be used for emergency services, supplementary tests may be required, to the satisfaction of the Society. In particular, for engines intended to drive emergency generating sets, additional tests and/or documents may be required to prove that the engine is capable of being readily started at a temperature of 0°C, as required in [3.1.3].

In the case of prototype engines, the duration and programme of the type test will be specially considered by the Society.

4.3.3 In cases of engines for which the Manufacturer submits documentary evidence proving successful service experience or results of previous bench tests, the Society, at its discretion, may allow a type test to be carried out in the presence of the Surveyor according to a programme to be agreed upon in each instance.

In the case of engines which are to be type approved for different purposes and performances, the programme and duration of the type test will be decided by the Society in each case to cover the whole range of engine performances for which approval is requested, taking into account the most severe values.

4.3.4 During the type test, at least the following particulars are to be recorded:

- a) ambient air temperature, pressure and atmospheric humidity in the test room
- b) cooling raw water temperature at the inlet of heat exchangers
- c) characteristics of fuel and lubricating oil used during the test
- d) engine speed

- e) brake power
- f) brake torque
- g) maximum combustion pressure
- h) indicated pressure diagrams, where practicable
- i) exhaust smoke (with a smoke meter deemed suitable by the Surveyor)
- j) lubricating oil pressure and temperature
- k) cooling water pressure and temperature
- l) exhaust gas temperature in the exhaust manifold and, where facilities are available, from each cylinder
- m) minimum starting air pressure necessary to start the engine in cold condition.

In addition to the above, for supercharged engines the following data are also to be measured and recorded:

- turbocharger speed
- air temperature and pressure before and after turbocharger and charge air coolers
- exhaust gas temperatures and pressures before and after turbochargers and cooling water temperature at the inlet of charge air coolers.

4.3.5 Inspection of main engine components and evaluation of test results

The provisions of [4.2.4] and [4.2.5] are to be complied with, as far as applicable.

4.4 Material and non-destructive tests

4.4.1 Material tests

Engine components are to be tested in accordance with Tab 5 and in compliance with the requirements of Part D.

Magnetic particle or liquid penetrant tests are required for the parts listed in Tab 5 and are to be effected in positions mutually agreed upon by the Manufacturer and the Society Surveyor, where experience shows defects are most likely to occur.

The magnetic particle test of tie rods/stay bolts is to be carried out at each end, for a portion which is at least twice the length of the thread.

For important structural parts of engines, in addition to the above-mentioned non-destructive tests, examination of welded seams by approved methods of inspection may be required.

Where there is evidence to doubt the soundness of any engine component, non-destructive tests using approved detecting methods may be required.

Engines of a cylinder diameter not exceeding 300 mm may be tested according to an alternative survey scheme.

Table 5 : Material and non-destructive tests

Engine component	Material tests (1) (Mechanical properties and chemical composition)	Non-destructive tests	
		Magnetic particle or liquid penetrant	Ultrasonic
1) Crankshaft	all	all	all
2) Crankshaft coupling flange (non-integral) for main power transmissions	if bore > 400 mm	-	-
3) Coupling bolts for crankshaft	if bore > 400 mm	-	-
4) Steel piston crowns (2)	if bore > 400 mm	if bore > 400 mm	all
5) Piston rods	if bore > 400 mm	if bore > 400 mm	if bore > 400 mm
6) Connecting rods, together with connecting rod bearing caps	all	all	if bore > 400 mm
7) Crossheads	if bore > 400 mm	-	-
8) Cylinder liners	if bore > 300 mm	-	-
9) Steel cylinder covers (2)	if bore > 300 mm	if bore > 400 mm	all
10) Bedplates of welded construction; plates and transverse bearing girders made of forged or cast steel (2) (3)	all	all	all
11) Frames and crankcases of welded construction (3)	all	-	-
12) Entablatures of welded construction (3)	all	-	-
13) Tie rods	all	if bore > 400 mm	-
14) Shafts and rotors, including blades, for turbochargers (4)	(see Sec 14)	-	-
15) Bolts and studs for cylinder covers, crossheads, main bearings and connecting rod bearings; nuts for tie rods	if bore > 300 mm	if bore > 400 mm	-
16) Steel gear wheels for camshaft drives	if bore > 400 mm	if bore > 400 mm	-
<p>(1) In addition, material tests may also be required, at the Society's discretion, for piping and valves for starting air lines and any other pressure piping fitted on the engines.</p> <p>(2) For items 4), 9) and 10), it is implicit that as well as for steel parts, material tests are also required for parts made of other materials which are comparable to steel on account of their mechanical properties in general and their ductility in particular: e.g. aluminium and its alloys, ductile and spheroidal or nodular graphite cast iron.</p> <p>(3) Material tests for bedplates, frames, crankcases and entablatures are required even if these parts are not welded and for any material except grey cast iron.</p> <p>(4) Turbocharger is understood as turbocharger itself and engine driven compressor (incl. "Root blowers", but not auxiliary blowers)</p>			

4.4.2 Hydrostatic tests

Parts of engines under pressure are to be hydrostatically tested at the test pressure specified for each part in Tab 6.

The following parts of auxiliaries which are necessary for operation of engines as per [1.1.1] a), b) and c):

- cylinders, cylinder covers, coolers and receivers of independent air compressors
- water, oil and air coolers (tube bundles or coils, shells and heads) not fitted on the engine and filters
- independently driven lubricating oil, fuel oil and water pumps
- pressure pipes (water, lubricating oil, fuel oil, and compressed air pipes), valves and other fittings

are to be subjected to hydrostatic tests at 1,5 times the maximum working pressure, but not less than 0,4 MPa.

4.5 Workshop inspections and testing

4.5.1 General

In addition to the type test, diesel engines are to be subjected to works trials, which are to be witnessed by the Surveyor except where an Alternative Inspection Scheme has been granted or where otherwise decided by the Society on a case by case basis.

Engines which are to be subjected to trials on the test bed at the Manufacturer's works and under the Society's supervision are to be tested in accordance with the scope as specified below.

Exceptions to this require the agreement of the Society.

For all stages at which the engine is to be tested, the relevant operating values are to be measured and recorded by the engine Manufacturer.

In each case all measurements conducted at the various load points are to be carried out at steady operating conditions.

The readings for 100% of the rated power P at the corresponding speed n are to be taken twice at an interval of at least 30 minutes.

At the discretion of the Surveyor, the programme of trials given in [4.5.2], [4.5.3] or [4.5.4] may be expanded depending on the engine application.

Integration tests for electronically controlled diesel engines are to be carried out to verify that the response of the complete mechanical, hydraulic and electronic system is as pre-

dicted for all intended operational modes. The scope of these tests is to be agreed with the Society for selected cases based on the FMEA required in Tab 1.

Engines for which an Alternative Inspection Scheme has been agreed with the Manufacturer are to be subjected to trials at the Manufacturer's works in accordance with a procedure previously accepted on a case-by-case basis by the Society and recorded in the documentation relevant to the admission to the Alternative Inspection Scheme.

Table 6 : Test pressure of engine parts

Parts under pressure		Test pressure (MPa) (1) (2)
1	Cylinder cover, cooling space (3)	0,7
2	Cylinder liner, over the whole length of cooling space	0,7
3	Cylinder jacket, cooling space	0,4 (but not less than 1,5 p)
4	Exhaust valve, cooling space	0,4 (but not less than 1,5 p)
5	Piston crown, cooling space (3) (4)	0,7
6	Fuel injection system a) Fuel injection pump body, pressure side b) Fuel injection valve c) Fuel injection pipes	1,5 p (or p + 30, if lesser) 1,5 p (or p + 30, if lesser) 1,5 p (or p + 30, if lesser)
7	Hydraulic system • Piping, pumps, actuators etc. for hydraulic drive of valves	1,5 p
8	Scavenge pump cylinder	0,4
9	Turbocharger, cooling space	0,4 (but not less than 1,5p)
10	Exhaust pipe, cooling space	0,4 (but not less than 1,5 p)
11	Engine driven air compressor (cylinders, covers, intercoolers and aftercoolers) a) Air side b) Water side	1,5 p 0,4 (but not less than 1,5 p)
12	Coolers, each side (5)	0,4 (but not less than 1,5 p)
13	Engine driven pumps (oil, water, fuel, bilge)	0,4 (but not less than 1,5 p)
<p>(1) In general, parts are to be tested at the hydraulic pressure indicated in the Table. Where design or testing features may call for modification of these testing requirements, special consideration will be given by the Society.</p> <p>(2) p is the maximum working pressure, in MPa, in the part concerned.</p> <p>(3) For forged steel cylinder covers and forged steel piston crowns, test methods other than hydrostatic testing may be accepted, e.g. suitable non-destructive tests and documented dimensional tests.</p> <p>(4) Where the cooling space is sealed by the piston rod, or by the piston rod and the shell, the pressure test is to be carried out after assembly.</p> <p>(5) Turbocharger air coolers need to be tested on the water side only.</p>		

4.5.2 Main propulsion engines driving propellers

Main propulsion engines are to be subjected to trials to be performed as follows:

- a) at least 60 min, after having reached steady conditions, at rated power P and rated speed n
- b) 30 min, after having reached steady conditions, at 110% of rated power P and at a speed equal to 1,032 of rated speed
- c) tests at 90% (or normal continuous cruise power), 75%, 50% and 25% of rated power P, carried out:
 - at the speed corresponding to the nominal (theoretical) propeller curve, for engines driving fixed pitch propellers
 - at constant speed, for engines driving controllable pitch propellers
- d) idle run
- e) starting and reversing tests (when applicable)
- f) testing of the speed governor and of the independent overspeed protective device
- g) testing of alarm and/or shutdown devices.

Note 1: After running on the test bed, the fuel delivery system is to be so adjusted that the engine cannot deliver more than 100% of the rated power at the corresponding speed (overload power cannot be obtained in service).

4.5.3 Engines driving electric generators used for main propulsion purposes

Engines driving electric generators are to be subjected to trials to be performed with a constant governor setting, as follows:

- a) at least 60 min, after having reached steady conditions, at 100% of rated power P and rated speed n
- b) 45 min, after having reached steady conditions, at 110% of rated power and rated speed
- c) 75%, 50% and 25% of rated power P, carried out at constant rated speed n
- d) idle run
- e) starting tests
- f) testing of the speed governor ([2.7.5]) and of the independent overspeed protective device (when applicable)
- g) testing of alarm and/or shutdown devices.

Note 1: After running on the test bed, the fuel delivery system of diesel engines driving electric generators is to be adjusted such that overload (110%) power can be produced but not exceeded in service after installation on board, so that the governing characteristics, including the activation of generator protective devices, can be maintained at all times.

4.5.4 Engines driving auxiliary machinery

Engines driving auxiliary machinery are to be subjected to the tests stated in [4.5.2] or [4.5.3] for variable speed and constant speed drives, respectively.

Note 1: After running on the test bed, the fuel delivery system of diesel engines driving electric generators is to be adjusted such that overload (110%) power can be produced but not exceeded in service after installation on board, so that the governing characteristics, including the activation of generator protective devices, can be fulfilled at all times.

4.5.5 Inspection of engine components

After the works trials, several components are to be selected for inspection by the Manufacturer or by the Surveyor if the works trials are witnessed.

4.5.6 Parameters to be measured

The data to be measured and recorded, when testing the engine at various load points, are to include all necessary parameters for engine operation. The crankshaft deflection is to be verified when this check is required by the Manufacturer during the operating life of the engine.

4.5.7 Testing report

In the testing report for each engine the results of the tests carried out are to be compiled and the reference number and date of issue of the Type Approval Certificate (see [4.6]), relevant to the engine type, are always to be stated; the testing report is to be issued by the Manufacturer and enclosed with the testing certificate as per [4.6].

4.6 Certification

4.6.1 Type Approval Certificate and its validity

After the satisfactory outcome of the type tests and inspections specified in [4.2] or [4.3], the Society will issue to the engine manufacturer a "Type Approval Certificate" valid for all engines of the same type.

The Society reserves the right to consider the test carried out on one engine type valid also for engines having a different cylinder arrangement, following examination of suitable, detailed documentation submitted by the Manufacturer and including bench test results.

4.6.2 Testing certification

- a) Engines admitted to an alternative inspection scheme
 - Works' certificates (W) (see Pt D, Ch 1, Sec 1, [4.2.3]) are required for components and tests indicated in Tab 5 and Tab 6 and for works trials as per [4.5].
- b) Engines not admitted to an alternative inspection scheme
 - Society's certificates (C) (see Pt D, Ch 1, Sec 1, [4.2.1]) are required for material tests of components in Tab 5 and for works trials as per [4.5].
 - Works' certificates (W) (see Pt D, Ch 1, Sec 1, [4.2.3]) are required for non-destructive and hydrostatic tests of components in Tab 5 and Tab 6.

In both cases a) and b), the Manufacturer is to supply:

- a) the following information:
 - engine type
 - rated power
 - rated speed
 - driven equipment
 - operating conditions
 - list of auxiliaries fitted on the engine
- b) a statement certifying that the engine is in compliance with that type tested. The reference number and date of the Type Approval Certificate are also to be indicated in the statement.

SECTION 3

BOILERS AND PRESSURE VESSELS

1 General

1.1 Principles

1.1.1 Scope of the Rules

The boilers and other pressure vessels, associated piping systems and fittings shall be of a design and construction adequate for the service for which they are intended and shall be so installed and protected as to reduce to a minimum any danger to persons on board, due regard being paid to moving parts, hot surfaces and other hazards. The design is to have regard to materials used in construction, the purpose for which the equipment is intended, the working conditions to which it will be subjected and the environmental conditions on board.

1.1.2 Continuity of service

The Society shall give special consideration to the reliability of single essential propulsion components and may require a separate source of propulsion power sufficient to give the ship a navigable speed, especially in the case of unconventional arrangements.

1.1.3 Propulsion capability

Means shall be provided whereby normal operation of main boilers can be sustained or restored even though one of the essential auxiliaries becomes inoperative. Special consideration is to be given to the malfunctioning of:

- the sources of steam supply
- the boiler feed water systems
- the fuel oil supply systems for boilers;
- the mechanical air supply for boilers.

However, the Society, having regard to overall safety considerations, may accept a partial reduction in propulsion capability from normal operation.

1.1.4 Tests

All boilers and other pressure vessels including their associated fittings which are under internal pressure shall be subjected to appropriate tests including a pressure test before being put into service for the first time (see also [7]).

1.1.5 Protection against overpressure

Where main or auxiliary boilers and other pressure vessels or any parts thereof may be subject to dangerous overpressure, means shall be provided where practicable to protect against such excessive pressure.

1.2 Application

1.2.1 Boilers and pressure vessels covered by the Rules

The requirements of this Section apply to:

- all boilers and other steam generators, including the associated fittings and mountings with the exception of those indicated in [1.2.2]
- pressure vessels of metallic construction and heat exchangers, including the associated fittings and mountings with the exception of those indicated in [1.2.2].

1.2.2 Boilers and pressure vessels not covered by the Rules

The following boilers and pressure vessels are not covered by the Rules and will be considered on a case by case basis:

- a) boilers with design pressure $p > 10$ MPa
- b) pressure vessels intended for radioactive material
- c) small pressure vessels included in self-contained domestic equipment.

1.2.3 Pressure vessels not requiring design approval

Plan approval is not required for pressure vessels of class 3 (as specified in [1.4]), having design pressure $p \leq 1$ MPa and product $pV \leq 150$ (V being the internal volume, in dm^3 , calculated deducting the volume of tube bundles, if any).

However, the Society reserves the right to apply all or part of the requirements of this Section to class 3 heat exchangers and pressure vessels, depending on the criticality of the equipment and/or of the system of which they are part.

1.3 Definitions

1.3.1 Pressure vessel

Pressure vessel is a welded or seamless container used for the containment of fluids at a pressure above or below the ambient pressure and at any temperature. Fluid power cylinders in hydraulic or pneumatic plants are also considered pressure vessels.

1.3.2 Fired pressure vessel

Fired pressure vessel is a pressure vessel which is completely or partially exposed to fire from burners or combustion gases.

1.3.3 Unfired pressure vessel

Any pressure vessel which is not a fired pressure vessel is an unfired pressure vessel.

1.3.4 Boiler

- a) Boiler is one or more fired pressure vessels and associated piping systems used for generating steam or hot water at a temperature above 120°C by means of heat

resulting from combustion of fuel or from combustion gases.

- b) Any equipment directly connected to the boiler, such as economisers, superheaters, and safety valves, is considered as part of the boiler, if it is not separated from the steam generator by means of any isolating valve. Piping connected to the boiler is considered part of the boiler upstream of the isolating valve and part of the associated piping system downstream of the isolating valve.

1.3.5 Steam generator

Steam generator is a heat exchanger and associated piping used for generating steam. In general, in these Rules, the requirements for boilers are also applicable for steam generators, unless otherwise indicated.

1.3.6 Heat exchanger

Heat exchanger is a pressure vessel used to heat or cool a fluid with another fluid. In general heat exchangers are composed of a number of adjacent chambers, the two fluids flowing separately in adjacent chambers. One or more chambers may consist of bundles of tubes.

1.3.7 Superheaters, economisers, reheaters, de-superheaters

Superheaters, economisers, reheaters and de-superheaters are heat exchangers associated with a boiler.

1.3.8 Incinerator

Incinerator is a shipboard facility for incinerating solid garbage approximating in composition to household garbage and liquid garbage deriving from the operation of the ship (e.g. domestic garbage, cargo-associated garbage, maintenance garbage, operational garbage, cargo residue, and fishing gear), as well as for burning sludge with a flash point above 60°C.

These facilities may be designed to use the heat energy produced.

1.3.9 Design pressure

The design pressure is the pressure used by the manufacturer to determine the scantlings of the vessel. This pressure cannot be taken less than the maximum working pressure and is to be limited by the set pressure of the safety valve, as prescribed by the applicable Rules.

1.3.10 Design temperature

- a) Design temperature is the actual metal temperature of the applicable part under the expected operating conditions, as modified in Tab 1. This temperature is to be stated by the manufacturer and is to take account of the effect of any temperature fluctuations which may occur during the service.
- b) The design temperature is to be not less than the temperatures stated in Tab 1, unless specially agreed between the manufacturer and the Society on a case by case basis.

For boilers the design temperature is to be not less than 250 °C.

1.3.11 Boiler heating surface

Heating surface is the area of that part of the boiler through which the heat is supplied to the medium, measured on the side exposed to fire or hot gas.

1.3.12 Maximum steam output

Maximum steam output is the maximum quantity of steam that can be produced continuously by the boiler or steam generator operating under the design steam conditions.

1.3.13 Toxic and corrosive substances

Toxic and corrosive substances are those which are listed in the IMO "International Maritime Dangerous Goods Code (IMDG Code)", as amended.

1.3.14 Ductile material

For the purpose of this Section, ductile material is a material having an elongation over 12%.

Table 1 : Minimum design temperature

TYPE OF VESSEL	MINIMUM DESIGN TEMPERATURE
Pressure parts of pressure vessels and boilers not heated by hot gases or adequately protected by insulation	Maximum temperature of the internal fluid
Pressure vessel heated by hot gases	25°C in excess of the temperature of the internal fluid
Water tubes of boilers mainly subjected to convection heat	25°C in excess of the temperature of the saturated steam
Water tubes of boilers mainly subjected to radiant heat	50°C in excess of the temperature of the saturated steam
Superheater tubes of boilers mainly subjected to convection heat	35°C in excess of the temperature of the saturated steam
Superheater tubes of boilers mainly subjected to radiant heat	50°C in excess of the temperature of the saturated steam
Economiser tubes	35°C in excess of the temperature of the internal fluid
For combustion chambers of the type used in wet-back boilers	50°C in excess of the temperature of the internal fluid
For furnaces, fire-boxes, rear tube plates of dry-back boilers and other pressure parts subjected to similar rate of heat transfer	90°C in excess of the temperature of the internal fluid

Table 2 : Pressure vessels classification

Equipment	class 1	class 2	class 3
Boilers	$p > 0,35$ MPa	$p \leq 0,35$ MPa	-
Steam heated generators or steam generators heated by another fluid	$p > 1,15$ MPa, or $p \cdot D > 1500$	All steam generators which are not class 1	-
Pressure vessels and heat exchangers	$p > 4$ MPa, or $t_A > 40$ mm, or $T > 350^\circ\text{C}$	$1,75 < p \leq 4$ MPa, or $15 < t_A \leq 40$ mm, or $150 < T \leq 350^\circ\text{C}$, or $p \cdot t_A > 15$	All pressure vessels and heat exchangers which are not class 1 or 2
Pressure vessels for toxic substances	All	-	-
Pressure vessels for corrosive substances	$p > 4$ MPa, or $t_A > 40$ mm, or $T > 350^\circ\text{C}$	All pressure vessels which are not class 1	-

Note 1: Whenever the class is defined by more than one characteristic, the equipment is to be considered belonging to the highest class of its characteristics, independently of the values of the other characteristics.

Table 3 : Drawings to be submitted for boilers and steam generators

No.	A/I	Item
1	I	General arrangement plan including valves and fittings
2	A	Material specifications
3	A	Sectional assembly
4	A	Evaporating parts
5	A	Superheater
6	A	De-superheater
7	A	Economiser
8	A	Air heater
9	A	Tubes and tube plates
10	A	Nozzles and fittings
11	A	Safety valves and their arrangement
12	A	Boiler seating
13	I	Fuel oil burning arrangement
14	I	Forced draft system
15	I	Refractor or insulation arrangement
16	A	Boiler instrumentation, monitoring and control system
17	A	Type of safety valves and their lift, discharge rate and setting
18	A	Welding details, including at least: <ul style="list-style-type: none"> • Typical weld joint design • Welding procedure specifications • Post-weld heat treatment

Note 1: A = to be submitted for approval in four copies
I = to be submitted for information in duplicate

1.4 Classes

1.4.1 Boilers and pressure vessels are classed as indicated in Tab 2 in consideration of their service, characteristics and scantlings. The symbols used in the table have the following meanings:

- p : Design pressure, in MPa
 T : Design temperature, in °C
 D : Inside diameter of the vessel, in mm
 t_A : Actual thickness of the vessel, in mm

1.5 Alternative standards

1.5.1

- a) All boilers and pressure vessels are to be designed, constructed, installed and tested in accordance with the applicable requirements of this Section.
- b) The acceptance of national and international standards as an alternative to the requirements of this Section may be considered by the Society on a case by case basis.

1.6 Documentation to be submitted

1.6.1 Boilers

The plans listed in Tab 3 are to be submitted.

The drawings listed in Tab 3 are to contain at least: the constructional details of all pressure parts, such as shells, headers, tubes, tube plates, nozzles; all strengthening members, such as stays, brackets, opening reinforcements and covers; installation arrangements, such as saddles and anchoring system; as well as the information and data indicated in Tab 4.

1.6.2 Other pressure vessels and heat exchangers

The plans listed in Tab 5 are to be submitted.

The drawings listed in Tab 5 are to contain at least the constructional details of all pressure parts, such as shells, headers, tubes, tube plates, nozzles, opening reinforcements and covers, and of all strengthening members, such as stays, brackets and reinforcements.

Table 4 : Information and data to be submitted for boilers and steam generators

No.	Item
1	Design pressure and temperature
2	Pressure and temperature of the superheated steam
3	Pressure and temperature of the saturated steam
4	Maximum steam production per hour
5	Evaporating surface of the tube bundles and water-walls
6	Heating surface of the economiser, superheater and air-heater
7	Surface of the furnace
8	Volume of the combustion chamber
9	Temperature and pressure of the feed water
10	Type of fuel to be used and fuel consumption at full steam production
11	Number and capacity of burners

Table 5 : Drawings, information and data to be submitted for pressure vessels and heat exchangers

No.	A/I	Item
1	I	General arrangement plan including nozzles and fittings
2	A	Sectional assembly
3	A	Material specifications
4	A	Welding details, including at least: <ul style="list-style-type: none"> • Typical weld joint design • Welding procedure specifications • Post-weld heat treatments
5	I	Design data, including at least design pressure and design temperatures (as applicable)
6	A	For seamless (extruded) pressure vessels, the manufacturing process including: <ul style="list-style-type: none"> • A description of the manufacturing process with indication of the production controls normally carried out in the manufacturer's works • Details of the materials to be used (specification, yield point, tensile strength, impact strength, heat treatment) • Details of the stamped marking to be applied
7	I	Type of fluid or fluids contained
Note 1: A = to be submitted for approval in four copies I = to be submitted for information in duplicate		

1.6.3 Incinerators

Incinerators will be considered on a case by case basis, based on their actual arrangement, using the applicable requirements for boilers and pressure vessels.

2 Design and Construction - Principles

2.1 Materials

2.1.1 Materials for high temperatures

- Materials for pressure parts having a design temperature exceeding the ambient temperature are to have mechanical and metallurgical properties adequate for the design temperature. Their allowable stress limits are to be determined as a function of the temperature, as per [3.2].
- When the design temperature of pressure parts exceeds 400°C, alloy steels are to be used. Other materials are subject of special consideration by the Society.

2.1.2 Materials for low temperatures

Materials for pressure parts having a design temperature below the ambient temperature are to have notch toughness properties suitable for the design temperature.

2.1.3 Cast iron

Grey cast iron is not to be used for:

- class 1 and class 2 pressure vessels
- class 3 pressure vessels with design pressure $p > 0,7\text{MPa}$ or product $pV > 15$, where V is the internal volume of the pressure vessel in m^3
- Bolted covers and closures of pressure vessels having a design pressure $p > 1\text{MPa}$, except for covers intended for boiler shells, for which [2.2.3] applies.

Spheroidal cast iron may be used subject to the agreement of the Society following special consideration. However, it is not to be used for parts having a design temperature exceeding 350°C.

2.1.4 Valves and fittings for boilers

- Ductile materials are to be used for valves and fittings intended to be mounted on boilers. The material is to have mechanical and metallurgical characteristics suitable for the design temperature and for the thermal and other loads imposed during the operation.
- Grey cast iron is not to be used for valves and fittings which are subject to dynamic loads, such as safety valves and blow-down valves, and in general for fittings and accessories having design pressure p exceeding 0,3 MPa and design temperature T exceeding 220°C.
- Spheroidal cast iron is not to be used for parts having a design temperature T exceeding 350°C.
- Bronze is not to be used for parts having design temperature T exceeding 220°C for normal bronzes and 260°C for bronzes suitable for high temperatures. Copper and aluminium brass are not to be used for fittings with design temperature T above 200°C and copper-nickel for fittings with design temperature T exceeding 300°C.

2.1.5 Alternative materials

In the case of boilers or pressure vessels constructed in accordance with one of the standards considered acceptable by the Society as per [1.5], the material specifications are to be in compliance with the requirements of the standard used.

2.2 Boilers and other steam generators

2.2.1 Insulation of headers and combustion chambers

Those parts of headers and/or combustion chambers which are not protected by tubes and are exposed to radiant heat or to high temperature gases are to be covered by suitable insulating material.

2.2.2 Connections of tubes to drums and tube plates

Tubes are to be adequately secured to drums and/or tube plates by expansion, welding or other appropriate procedure.

- Where the tubes are secured by expanding or equivalent process, the height of the shoulder bearing the tube, measured parallel to the tube axis, is to be at least 1/5 of the hole diameter, but not less than 9 mm for tubes normal to the tube plate or 13 mm for tubes angled to the tube plate. The tubes ends are not to project over the other face of the tube plate more than 6 mm.
- The tube ends intended to be expanded are to be partially annealed when the tubes have not been annealed by the manufacturer.

2.2.3 Access arrangement

- Boilers are to be provided with openings in sufficient number and size to permit internal examination, cleaning and maintenance operations. In general, all pressure vessels which are part of a boiler with inside diameter exceeding 1200 mm, and those with inside diameter exceeding 800 mm and length exceeding 2000 mm, are to be provided with access manholes.
- Manholes are to be provided in suitable locations in the shells, headers, domes, and steam and water drums, as

applicable. The "net" (actual hole) dimension of elliptical or similar manholes is to be not less than 300 mm x 400 mm. The "net" diameter of circular manholes (actual hole) cannot be less than 400 mm. The edges of manholes are to be adequately strengthened to provide compensation for vessel openings in accordance with [3.3.10] and [3.4.8], as applicable.

- In pressure vessels which are part of a boiler and are not covered by the requirement in a) above, or where an access manhole cannot be fitted, at least the following openings are to be provided, as far as practicable:
 - Head holes: minimum dimensions: 220mm x 320mm (320 mm diameter if circular)
 - Handholes: minimum dimensions: 87mm x 103mm
 - Sight holes: minimum diameter: 50 mm.
- Sight holes may only be provided when the arrangement of manholes, head holes, or handholes is impracticable.
- Covers for manholes and other openings are to be made of ductile steel, dished or welded steel plates or other approved design. Grey cast iron may be used only for small openings, such as handholes and sight holes, provided the design pressure p does not exceed 1 MPa and the design temperature T does not exceed 220°C.
- Covers are to be of self-closing internal type. Opening covers of other type, having a diameter not exceeding 150 mm, may be accepted by the Society.
- Covers of the internal type are to have a spigot passing through the opening. The clearance between the spigot and the edge of the opening is to be uniform for the whole periphery of the opening and is not to exceed 1,5 mm. Fig 1 shows a typical arrangement.
- Closing devices of internal type covers, having dimensions not exceeding 180mm x 230mm, may be fitted with a single fastening bolt or stud. Larger closing devices are to be fitted with at least two bolts or studs. For fastening bolt or stud arrangement see Fig 1.
- Covers are to be designed so as to prevent the dislocation of the required gasket by the internal pressure. Only continuous ring gaskets may be used for packing.

Figure 1 : Opening cover

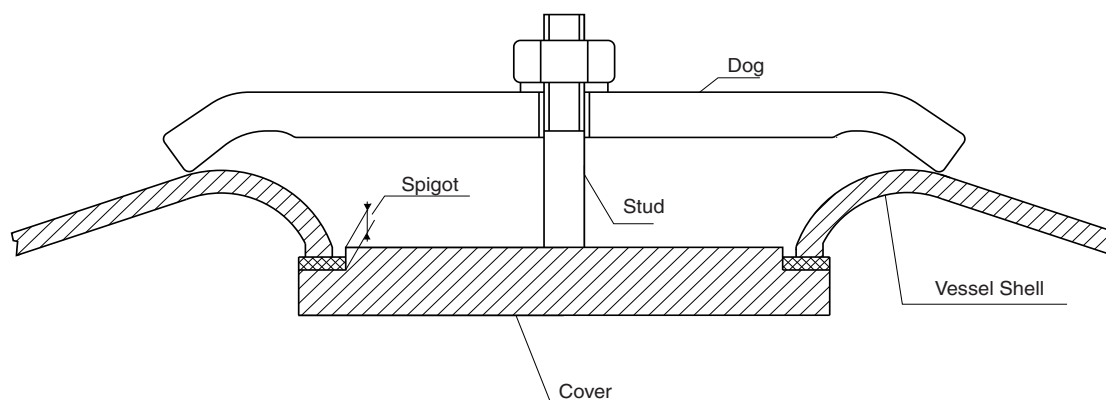

2.2.4 Fittings

- a) In general, cocks and valves are to be designed in accordance with the requirements in Sec 10, [2.7.2].
- b) Cocks, valves and other fittings are to be connected directly or as close as possible to the boiler shell.
- c) Cocks and valves for boilers are to be arranged in such a way that it can be easily seen when they are open or closed and so that their closing is obtained by a clockwise rotation of the actuating mechanism.

2.2.5 Boiler burners

Burners are to be arranged so that they cannot be withdrawn unless the fuel supply to the burners is cut off.

2.2.6 Allowable water levels

- a) In general, for water tube boilers the lowest permissible water level is just above the top row of tubes when the water is cold. Where the boiler is designed not to have fully submerged tubes, when the water is cold, the lowest allowable level indicated by the manufacturer is to be indicated on the drawings and submitted to the Society for consideration.
- b) For fire tube boilers with combustion chamber integral with the boiler, the minimum allowable level is to be at least 50 mm above the highest part of the combustion chamber.
- c) For vertical fire tube boilers the minimum allowable level is 1/2 of the length of the tubes above the lower tube sheet.

2.2.7 Steam outlets

- a) Each boiler steam outlet, if not serving safety valves, integral superheaters and other appliances which are to have permanent steam supply during boiler operation, is to be fitted with an isolating valve secured either directly to the boiler shell or to a standpipe of substantial thickness, as short as possible, and secured directly to the boiler shell.
- b) The number of auxiliary steam outlets is to be reduced to a minimum for each boiler.
- c) Where several boilers supply steam to common mains, the arrangement of valves is to be such that it is possible to positively isolate each boiler for inspection and maintenance. In addition, for water tube boilers, non-return devices are to be fitted on the steam outlets of each boiler.
- d) Where steam is used for essential auxiliaries (such as whistles, steam operated steering gears, steam operated electric generators, etc.) and when several boilers are fitted on board, it is to be possible to supply steam to these auxiliaries with any one of these boilers out of operation.
- e) Each steam stop valve exceeding 150 mm nominal diameter is to be fitted with a bypass valve.

2.2.8 Feed check valves

- a) Each fired boiler supplying steam to essential services is to be fitted with at least two feed check valves connected to two separate feed lines. For unfired steam generators a single feed check valve may be allowed.
- b) Feed check valves are to be secured directly to the boiler or to an integral economiser. Water inlets are to be separated. Where, however, feed check valves are secured to an economiser, a single water inlet may be allowed provided that each feed line can be isolated without stopping the supply of feed water to the boiler.
- c) Where the economisers may be bypassed and cut off from the boiler, they are to be fitted with pressure-limiting type valves, unless the arrangement is such that excessive pressure cannot occur in the economiser when cut off.
- d) Feed check valves are to be fitted with control devices operable from the stokehold floor or from another appropriate location. In addition, for water tube boilers, at least one of the feed check valves is to be arranged so as to permit automatic control of the water level in the boiler.
- e) Provision is to be made to prevent the feed water from getting in direct contact with the heated surfaces inside the boiler and to reduce, as far as possible and necessary, the thermal stresses in the walls.

2.2.9 Blow-down devices

- a) Each boiler is to be fitted with at least one bottom blow-down valve or cock and, where necessary, with a similar valve or cock for scumming from the surface. These valves or cocks are to be secured directly to the boiler shell and are to be connected to overboard discharge pipes.
- b) The diameter of valves or cocks and of the connected piping is not to be less than 20 mm and need not be more than 40 mm.
- c) Where the bottom blow-down valve may not be directly connected to the boiler shell in water tube boilers, the valve may be placed immediately outside the boiler casing with a pipe of substantial thickness suitably supported and protected from the heat of the combustion chamber.
- d) Where two or more boilers have the bottom blow-down and surface scumming-off valves connected to the same discharge, the relevant valves and cocks are to be of the non-return type to prevent the possibility of the contents of one boiler passing to another.

2.2.10 Drains

Each superheater, whether or not integral with the boiler, is to be fitted with cocks or valves so arranged that it is possible to drain it completely.

2.2.11 Water sample

- a) Every boiler shall be provided with means to supervise and control the quality of the feed water. Suitable arrangements shall be provided to preclude, as far as

practicable, the entry of oil or other contaminants which may adversely affect the boiler.

- b) For this purpose, boilers are to be fitted with at least one water sample cock or valve. This device is not to be connected to the water level standpipes.
- c) Suitable inlets for water additives are to be provided in each boiler.

2.2.12 Marking of boilers

- a) Each boiler is to be fitted with a permanently attached plate made of non-corrosive metal, with indication of the following information, in addition to the identification marks (name of manufacturer, year and serial number):
 - the design pressure
 - the design temperature
 - the test pressure and the date of the test
- b) Markings may be directly stamped on the vessel if this does not produce notches having an adverse influence on its behaviour in service.
- c) For lagged vessels, these markings are also to appear on a similar plate fitted above the lagging.

2.3 Boiler and steam generator safety valves

2.3.1 Safety valve arrangement

- a) Every steam boiler and every steam generator with a total heating surface of 50 m² and above is to be provided with not less than two spring loaded safety valves of adequate capacity. For steam boilers and steam generators having heating surface less than 50 m², only one safety valve need be fitted.
- b) Where a superheater is an integral part of the boiler, at least one safety valve is to be located on the steam drum and at least one at the superheater outlet. The valves fitted at the superheater outlet may be considered as part of the boiler safety valves required in a) provided that their capacity does not account for more than 25% of the total capacity required in [2.3.2], unless specially considered by the Society.
- c) Where fitted, superheaters which may be shut-off from the boiler, are to be provided with at least one safety valve; such valve(s) cannot be considered as part of the boiler safety valves required in a).
- d) In the case of boilers fitted with a separate steam accumulator, safety valves may be fitted on the accumulator if no shut-off is provided between it and the boiler and if the connecting pipe is of a size sufficient to allow the whole steam production to pass through, without increasing the boiler pressure more than 10% above the design pressure.

2.3.2 Orifice minimum aggregate area

- a) The minimum aggregate area of the orifices of the safety valves in way of the seat is to be determined by the appropriate formula below.
 - Saturated steam:

$$A = c \cdot \frac{d}{h} \cdot \frac{W}{10,2 \cdot p + 1}$$

- Superheated steam:

$$A_s = c \cdot \frac{d}{h} \cdot \frac{W_s}{10,2 \cdot p + 1} \cdot \left(1 + \frac{T_s}{556}\right)$$

where:

A : Aggregate area, in mm², of the orifices in way of the seat, for saturated steam safety valves

A_s : Aggregate area, in mm², as defined above, for superheated steam safety valves

p : Maximum working pressure of the boiler or other steam generator, in MPa

p_s : Maximum working pressure of the superheated steam, in MPa

W : Maximum steam production, in kg/h.

Under no circumstances, the value of W is to be based on evaporating capacities (referring to evaporating surfaces of the boiler concerned) not less than the following:

- 14 kg/(m² × h) for exhaust gas heated boilers
- 29 kg/(m² × h) for coal fired or oil fired boilers
- 60 kg/(m² × h) for water walls of oil fired boilers

W_s : Steam relieving capacity, in kg/h, of the valves fitted at the superheater outlet. This capacity is to be such that, during the discharge of safety valves, a sufficient quantity of steam is circulated through the superheater to avoid damage

d/h : Ratio of the actual orifice diameter in way of the seat to the actual lift of the safety valve plug. The values of d/h are to be taken not less than 4 and not greater than 24.

For valves of common type, or where the lift of the plug is not known, the value d/h = 24 is to be used

c : 0,875 for safety valves whose relieving capacity has not been ascertained experimentally as specified hereunder

0,485/Z where Z is the flow coefficient, for valves of large relieving capacity ascertained experimentally as directed by the Society, in the presence of the Surveyor. The flow coefficient Z is to be taken as the ratio of 90% of the experimentally checked relieving capacity to the theoretical relieving capacity calculated with a flow coefficient equal to 1. Values of Z higher than 0,88 are not to be used

T_s : Temperature of superheated steam, in °C

- b) The orifice diameter in way of the safety valves seat is not to be less than 40 mm. Where only one safety valve need be fitted, the orifice minimum diameter is not to be less than 50 mm. Valves of large relieving capacity

with 15 mm minimum diameter may be accepted for boilers with steam production not exceeding 2000 kg/h.

- c) Independently of the above requirements, the aggregate capacity of the safety valves is to be such as to discharge all the steam that can be generated without causing a transient pressure rise of more than 10% over the design pressure.

2.3.3 Safety valves operated by pilot valves

The arrangement on the superheater of large relieving capacity safety valves, operated by pilot valves fitted in the saturated steam drum, is to be specially considered by the Society.

2.3.4 Steam heated steam generator protection

Steam heated steam generators are also to be protected against possible damage resulting from failure of the heating coils. In this case, the area of safety valves calculated as stated in [2.3.2] may need to be increased to the satisfaction of the Society, unless suitable devices limiting the flow of steam in the heating coils are provided.

2.3.5 Safety valve setting

- a) Safety valves are to be set under steam in the presence of the Surveyor to a pressure not higher than 1,03 times the design pressure.
- b) Safety valves are to be so constructed that their setting may not be increased in service and their spring may not be expelled in the event of failure. In addition, safety valves are to be provided with simple means of lifting the plug from its seat from a safe position in the boiler or engine room.
- c) Where safety valves are provided with means for regulating their relieving capacity, they are to be so fitted that their setting cannot be modified when the valves are removed for surveys.

2.3.6 Safety valve fitting on boiler

- a) The safety valves of a boiler are to be directly connected to the boiler and separated from other valve bodies.
- b) Where it is not possible to fit the safety valves directly on the superheater headers, they are to be mounted on a strong nozzle fitted as close as practicable to the superheater outlet. The cross-sectional area for passage of steam through restricted orifices of the nozzles is not to be less than 1/2 the aggregate area of the valves, calculated with the formulae of [2.3.2], when $d/h \geq 8$, and not less than the aggregate area of the valves, when $4 \leq d/h < 8$.
- c) Safety valve bodies are to be fitted with drain pipes of a diameter not less than 20 mm for double valves, and not less than 12 mm for single valves, leading to the bilge or to the hot well. Valves or cocks are not to be fitted on drain pipes.

2.3.7 Exhaust pipes

- a) The minimum cross-sectional area of the exhaust pipes of safety valves which have not been experimentally tested is not to be less than 11,5 h/d times the aggregate area as calculated by the formulae in [2.3.2]. However,

this area is not to be less than 1,1 times the safety valve aggregate area.

- b) The minimum cross-sectional area of the exhaust pipes of large relieving capacity safety valves whose capacity has been experimentally tested is to be not less than $18 Z \times h/d$ times the aggregate area calculated by the formulae in [2.3.2].
- c) The cross-sectional area of the exhaust manifold of safety valves is to be not less than the sum of the areas of the individual exhaust pipes connected to it.
- d) Silencers fitted on exhaust manifolds are to have a free passage area not less than that of the manifolds.
- e) The strength of exhaust manifolds and pipes and associated silencers is to be such that they can withstand the maximum pressure to which they may be subjected, which is to be assumed not less than 1/4 of the safety valve setting pressure.
- f) In the case that the discharges from two or more valves are led to the same exhaust manifold, provision is to be made to avoid the back pressure from the valve which is discharging influencing the other valves.
- g) Exhaust manifolds are to be led to the open and are to be adequately supported and fitted with suitable expansion joints or other means so that their weight does not place an unacceptable load on the safety valve bodies.

2.4 Pressure vessels

2.4.1 Access arrangement

The access requirements for boilers stated in [2.2.3], except item (f), are also applicable for other pressure vessels.

2.4.2 Safety valves

- a) Pressure vessels which are part of a system are to be provided with safety valves, or equivalent devices, if they are liable to be isolated from the system safety devices. This provision is also to be made in all cases in which the vessel pressure can rise, for any reason, above the design pressure. See also [6.3] for grouped pressure vessels.
- b) In particular, air pressure vessels which can be isolated from the safety valves ensuring their protection in normal service are to be fitted with another safety device, such as a rupture disc or a fusible plug, in order to ensure their discharge in case of fire. This device is to discharge to the open.
- c) Safety devices ensuring protection of pressure vessels in normal service are to be rated to operate before the pressure exceeds the maximum working pressure by more than 5%.

2.4.3 Protection of heat exchangers

Special attention is to be paid to the protection against overpressure of vessels, such as heat exchangers, which have parts that are designed for a pressure which is below that to which they might be subjected in the case of rupture of the tubular bundles or coils contained therein and that have been designed for a higher pressure.

2.4.4 Corrosion protection

Vessels and equipment containing media that might lead to accelerated corrosion are to be suitably protected.

2.4.5 Drainage

- a) Each air pressure vessel is to be fitted with a drainage device allowing the evacuation of any oil or water accumulated in the vessel.
- b) Drainage devices are also to be fitted on other vessels, in particular steam vessels, in which condensation water is likely to accumulate.

2.4.6 Marking

- a) Each pressure vessel is to be fitted with a permanently attached plate made of non-corrosive metal, with indication of the following information, in addition to the identification marks (name of manufacturer, year and serial number):
 - the design pressure
 - the design temperature
 - the test pressure and the date of the test
- b) Markings may be directly stamped on the vessel if this does not produce notches having an adverse influence on its behaviour in service.
- c) For smaller pressure vessels the indication of the design pressure only may be sufficient.

2.5 Thermal oil heaters and other pressure vessels associated with thermal oil installations

2.5.1 General

- a) The following requirements apply to thermal oil heaters in which organic liquids (thermal oils) are heated by oil fired burners, exhaust gases or electricity to temperatures below their initial boiling point at atmospheric pressure.
- b) Thermal oils are only to be used within the limits set by the manufacturer.
- c) Means are to be provided for manual operation. However, at least the temperature control device on the oil side and flow monitoring are to remain operative even in manual operation.
- d) Means are to be provided to take samples of thermal oil.

2.5.2 Thermal oil heaters

- a) Heaters are to be so constructed that neither the surfaces nor the thermal oil becomes excessively heated at any point. The flow of the thermal oil is to be ensured by forced circulation.
- b) The surfaces which come into contact with the thermal oil are to be designed for the design pressure, subject to the minimum pressure of 1 MPa.
- c) Copper and copper alloys are not permitted.
- d) Heaters heated by exhaust gas are to be provided with inspection openings at the exhaust gas intake and outlet.
- e) Oil fired heaters are to be provided with inspection openings for examination of the combustion chamber.

The opening for the burner may be considered as an inspection opening, provided its size is sufficient for this purpose.

- f) Heaters are to be fitted with means enabling them to be completely drained.
- g) Thermal oil heaters heated by exhaust gas are to be fitted with a permanent system for extinguishing and cooling in the event of fire, for instance a pressure water spraying system.

2.5.3 Safety valves

Each heater is to be equipped with at least one safety valve having a discharge capacity at least equal to the increase in volume of the thermal oil at the maximum heating power. During discharge the pressure may not increase above 10% over the design pressure.

2.5.4 Pressure vessels

The design pressure of all vessels which are part of a thermal oil system, including those open to the atmosphere, is to be taken not less than 0,2 MPa.

2.5.5 Equipment of the expansion, storage and drain tanks

For the equipment to be installed on expansion, storage and drain tanks, see Sec 10, [13].

2.5.6 Marking

Each thermal oil heater and other pressure vessels which are part of a thermal oil installation are to be fitted with a permanently attached plate made of non-corrosive metal, with indication of the following information, in addition to the identification marks (name of manufacturer, year and serial number):

- a) Heaters
 - Maximum allowable heating power
 - Design pressure
 - Maximum allowable discharge temperature
 - Minimum flow rate
 - Liquid capacity
- b) Vessels
 - Design pressure
 - Design temperature
 - Capacity.

2.6 Special types of pressure vessels

2.6.1 Seamless pressure vessels (bottles)

Each bottle is to be marked with the following information:

- Name or trade name of the manufacturer
- Serial number
- Type of gas
- Capacity
- Test pressure
- Empty weight
- Test stamp.

2.6.2 Steam condensers

- a) The water chambers and steam spaces are to be fitted with doors for inspection and cleaning.
- b) Where necessary, suitable diaphragms are to be fitted for supporting tubes.
- c) Condenser tubes are to be removable.
- d) High speed steam flow, where present, is to be prevented from directly striking the tubes by means of suitable baffles.
- e) Suitable precautions are to be taken in order to avoid corrosion on the circulating water side and to provide an efficient grounding.

2.7 Additional requirements for shell type exhaust gas economisers

2.7.1 Application

These requirements apply to shell type exhaust gas economisers that are intended to be operated in a flooded condition and that can be isolated from the steam piping system.

2.7.2 Design and Construction

Design and construction of shell type exhaust gas economisers are to pay particular attention to the welding, heat treatment and inspection arrangements at the tube plate connection to the shell.

2.7.3 Pressure Relief

The requirements given in [2.3.1] apply.

To avoid the accumulation of solid matter deposits on the outlet side of safety valves, the discharge pipes and safety valve housings are to be fitted with drainage arrangements from the lowest part, directed with continuous fall to a position clear of the shell type exhaust gas economisers where it will not pose threats to either personnel or machinery. No valves or cocks are to be fitted in the drainage arrangements.

2.7.4 Pressure Indication

Every shell type exhaust gas economiser is to be provided with a means of indicating the internal pressure located so that the pressure can be easily read from any position from which it may be controlled.

2.7.5 Lagging

Every shell type exhaust gas economiser is to be provided with removable lagging at the circumference of the tube end plates to enable ultrasonic examination of the tube plate to shell connection.

2.7.6 Feed Water

Every shell type exhaust gas economiser is to be provided with arrangements for preheating and de-aeration, addition of water treatment or combination thereof to control the quality of feed water to within the Manufacturer's recommendations.

2.7.7 Operating Instructions

The Manufacturer is to provide operating instructions for each shell type exhaust gas economiser which are to include reference to:

- a) Feed water treatment and sampling arrangements
- b) Operating temperatures - exhaust gas and feed water temperatures
- c) Operating pressure
- d) Inspection and cleaning procedures
- e) Records of maintenance and inspection
- f) The need to maintain adequate water flow through the economiser under all operating conditions
- g) Periodical operational checks of the safety devices to be carried out by the operating personnel and to be documented accordingly
- h) Procedures for using the exhaust gas economiser in the dry condition
- i) Procedures for maintenance and overhaul of safety valves.

3 Design and construction - Scantlings

3.1 General

3.1.1 Application

- a) In general, the formulae in this Section do not take into account additional stresses imposed by effects other than pressure, such as stresses deriving from the static and dynamic weight of the vessel and its content, external loads from connecting equipment and foundations, etc. For the purpose of the Rules these additional loads may be neglected, provided it can reasonably be presumed that the actual average stresses of the vessel, considering all these additional loads, would not increase more than 10% with respect to the stresses calculated by the formulae in this Section.
- b) Where it is necessary to take into account additional stresses, such as dynamic loads, the Society reserves the right to ask for additional requirements on a case by case basis.

3.1.2 Additional requirements

When pressure parts are of an irregular shape, such as to make it impossible to check the scantlings by applying the formulae of this Section, the approval is to be based on other means, such as burst and/or deformation tests on a prototype or by another method agreed upon between the manufacturer and the Society.

3.2 Permissible stresses

3.2.1 Permissible stress tables

The permissible stresses K , in N/mm^2 , for steels, to be used in the formulae of this Section, may be determined from Tab 6, Tab 7, Tab 8 and Tab 9, where R_m is the ultimate strength of the material in N/mm^2 . For intermediate values of the temperature, the value of K is to be obtained by linear interpolation.

Table 6 : Permissible stresses K for carbon steels intended for boilers and thermal oil heaters

Carbon steel	T (°C)	≤ 50	100	150	200	250	300	350	400
$R_m = 360 \text{ N/mm}^2$ Grade HA	$t \leq 15 \text{ mm}$	133	109	107	105	94	77	73	72
	$15 \text{ mm} < t \leq 40 \text{ mm}$	128	106	105	101	90	77	73	72
	$40 \text{ mm} < t \leq 60 \text{ mm}$	122	101	99	95	88	77	73	72
$R_m = 360 \text{ N/mm}^2$ Grades HB, HD	$t \leq 15 \text{ mm}$	133	127	116	103	79	79	72	69
	$15 \text{ mm} < t \leq 40 \text{ mm}$	133	122	114	102	79	79	72	69
	$40 \text{ mm} < t \leq 60 \text{ mm}$	133	112	107	99	79	79	72	69
$R_m = 410 \text{ N/mm}^2$ Grade HA	$t \leq 15 \text{ mm}$	152	132	130	126	112	94	89	86
	$15 \text{ mm} < t \leq 40 \text{ mm}$	147	131	124	119	107	94	89	86
	$40 \text{ mm} < t \leq 60 \text{ mm}$	141	120	117	113	105	94	89	86
$R_m = 410 \text{ N/mm}^2$ Grades HB, HD	$t \leq 15 \text{ mm}$	152	147	135	121	107	95	88	84
	$15 \text{ mm} < t \leq 40 \text{ mm}$	152	142	133	120	107	95	88	84
	$40 \text{ mm} < t \leq 60 \text{ mm}$	152	134	127	117	107	95	88	84
$R_m = 460 \text{ N/mm}^2$ Grades HB, HD	$t \leq 15 \text{ mm}$	170	164	154	139	124	111	104	99
	$15 \text{ mm} < t \leq 40 \text{ mm}$	169	162	151	137	124	111	104	99
	$40 \text{ mm} < t \leq 60 \text{ mm}$	162	157	147	136	124	111	104	99
$R_m = 510 \text{ N/mm}^2$ Grades HB, HD	$t \leq 60 \text{ mm}$	170	170	169	159	147	134	125	112

Table 7 : Permissible stresses K for carbon steels intended for other pressure vessels

Carbon steel	T (°C)	≤ 50	100	150	200	250	300	350	400
$R_m = 360 \text{ N/mm}^2$ Grade HA	$t \leq 15 \text{ mm}$	133	117	115	112	100	83	78	77
	$15 \text{ mm} < t \leq 40 \text{ mm}$	133	114	113	108	96	83	78	77
	$40 \text{ mm} < t \leq 60 \text{ mm}$	130	108	105	101	94	83	78	77
$R_m = 360 \text{ N/mm}^2$ Grades HB, HD	$t \leq 15 \text{ mm}$	133	133	123	110	97	85	77	73
	$15 \text{ mm} < t \leq 40 \text{ mm}$	133	131	122	109	97	85	77	73
	$40 \text{ mm} < t \leq 60 \text{ mm}$	133	119	115	106	97	85	77	73
$R_m = 410 \text{ N/mm}^2$ Grade HA	$t \leq 15 \text{ mm}$	152	141	139	134	120	100	95	92
	$15 \text{ mm} < t \leq 40 \text{ mm}$	152	134	132	127	114	100	95	92
	$40 \text{ mm} < t \leq 60 \text{ mm}$	150	128	121	112	112	100	95	92
$R_m = 410 \text{ N/mm}^2$ Grades HB, HD	$t \leq 15 \text{ mm}$	152	152	144	129	114	101	94	89
	$15 \text{ mm} < t \leq 40 \text{ mm}$	152	152	142	128	114	101	94	89
	$40 \text{ mm} < t \leq 60 \text{ mm}$	152	143	139	125	114	101	94	89
$R_m = 460 \text{ N/mm}^2$ Grades HB, HD	$t \leq 15 \text{ mm}$	170	170	165	149	132	118	111	105
	$15 \text{ mm} < t \leq 40 \text{ mm}$	170	170	161	147	132	118	111	105
	$40 \text{ mm} < t \leq 60 \text{ mm}$	170	167	157	145	132	118	111	105
$R_m = 510 \text{ N/mm}^2$ Grades HB, HD	$t \leq 60 \text{ mm}$	189	189	180	170	157	143	133	120

Table 8 : Permissible stresses K for alloy steels intended for boilers and thermal oil heaters

Alloy steel	T(°C)	≤ 50	100	150	200	250	300	350	400	450	475	500	525	550	575	600
0,3Mo	t ≤ 60 mm	159	153	143	134	125	106	100	94	91	89	87	36			
1Cr 0,5Mo	t ≤ 60 mm	167	167	157	144	137	128	119	112	106	104	103	55	31	19	
2,25Cr 1Mo (1)	t ≤ 60 mm	170	167	157	147	144	137	131	125	119	115	112	61	41	30	22
2,25Cr 1Mo (2)	t ≤ 60 mm	170	167	164	161	159	147	141	130	128	125	122	61	41	30	22
(1) Normalised and tempered																
(2) Normalised and tempered or quenched and tempered																

Table 9 : Permissible stresses K for alloy steels intended for other pressure vessels

Alloy steel	T(°C)	≤ 50	100	150	200	250	300	350	400	450	475	500	525	550	575	600
0,3Mo	t ≤ 60 mm	159	159	153	143	133	113	107	100	97	95	93	38			
1Cr 0,5Mo	t ≤ 60 mm	167	167	167	154	146	137	127	119	113	111	110	59	33	20	
2,25Cr 1Mo (1)	t ≤ 60 mm	183	174	167	157	154	146	140	133	127	123	119	65	44	32	23
2,25Cr 1Mo (2)	t ≤ 60 mm	174	174	174	172	170	157	150	139	137	133	130	65	44	32	23
(1) Normalised and tempered																
(2) Normalised and tempered or quenched and tempered																

3.2.2 Direct determination of permissible stresses

The permissible stresses K, where not otherwise specified, may be taken as indicated below.

a) Steel:

The permissible stress is to be the minimum of the values obtained by the following formulae:

$$K = \frac{R_{m,20}}{2,7}$$

$$K = \frac{R_{S,MIN,T}}{A}$$

$$K = \frac{S_A}{A}$$

where:

$R_{m,20}$: Minimum tensile strength at ambient temperature (20°C), in N/mm²

$R_{S,MIN,T}$: Minimum between R_{eH} and $R_{p 0,2}$ at the design temperature T, in N/mm²

S_A : Average stress to produce creep rupture in 100000 hours, in N/mm², at the design temperature T

A : Safety factor taken as follows, when reliability of $R_{S,MIN,T}$ and S_A values are proved to the Society's satisfaction:

- 1,6 for boilers and other steam generators
- 1,5 for other pressure vessels
- specially considered by the Society if average stress to produce creep rupture in more than 100000 hours is used instead of S_A

In the case of steel castings, the permissible stress K, calculated as above, is to be decreased by 20%. Where steel castings are subjected to non-destructive tests, a

smaller reduction up to 10% may be taken into consideration by the Society.

b) Spheroidal cast iron:

The permissible stress is to be the minimum of the values obtained by the following formulae:

$$K = \frac{R_{m,20}}{4,8}$$

$$K = \frac{R_{S,MIN,T}}{3}$$

c) Grey cast iron:

The permissible stress is obtained by the following formula:

$$K = \frac{R_{m,20}}{10}$$

d) Copper alloys:

The permissible stress is obtained by the following formula:

$$K = \frac{R_{m,T}}{4}$$

where:

$R_{m,T}$: Minimum tensile strength at the design temperature T, in N/mm²

e) Aluminium and aluminium alloys:

The permissible stress is to be the minimum of the values obtained by the following formulae:

$$K = \frac{R_{m,T}}{4}$$

$$K = \frac{R_{e,H}}{1,5}$$

where:

$R_{e,H}$: Minimum yield stress, in N/mm²

f) Additional conditions:

- In special cases the Society reserves the right to apply values of permissible stress K lower than those specified above.
- In the case of boilers or other steam generators, the permissible stress K is not to exceed 170 N/mm².
- For materials other than those listed above the permissible stress is to be agreed with the Society on a case by case basis.

3.3 Cylindrical, spherical and conical shells with circular cross-sections subject to internal pressure

3.3.1 Cylindrical shell thickness

- The minimum thickness of cylindrical, spherical and conical shells with circular cross-sections is not to be less than the value t, in mm, calculated by one of the following formulae, as appropriate. Cylindrical tube plates pierced by a great number of tube holes are to have thickness calculated by the applicable formula in [3.3.2], [3.3.3], [3.3.4] and [3.7.2].
- The thicknesses obtained by the formulae in [3.3.2], [3.3.3], [3.3.4], are "net" thicknesses, as they do not include any corrosion allowance. Unless a greater value is agreed in the vessel contract specification, the thickness obtained by the above formulae is to be increased by 0.75 mm. See also [3.3.7].

3.3.2 Cylindrical shells

- When the ratio external diameter/inside diameter is equal to or less than 1,5, the minimum thickness of cylindrical shells is given by the following formula:

$$t = \frac{pD}{2Ke - p}$$

where:

- p : Design pressure, in MPa
 D : Inside diameter of vessel, in mm
 K : Permissible stress, in N/mm², obtained as specified in [3.2]
 e : Efficiency of welded joint. For the value of the efficiency e, see [3.3.5].

- The minimum thickness of shells having ratio external diameter/inside diameter exceeding 1,5 is subject of special consideration.

3.3.3 Spherical shells

- When the ratio external diameter/inside diameter is equal to or less than 1,5, the minimum thickness of spherical shells is given by the following formula:

$$t = \frac{pD}{4Ke - p}$$

For the meaning of the symbols, see [3.3.2].

- The minimum thickness of shells having ratio external diameter/inside diameter exceeding 1,5 is subject of special consideration.

3.3.4 Conical shells

- The following formula applies to conical shells of thickness not exceeding 1/6 of the external diameter in way of the large end of the cone.

$$t = \frac{pD}{(2Ke - p) \cdot \cos \varphi}$$

For the meaning of the symbols, see [3.3.2].

D is measured in way of the large end of the cone and φ is the angle of slope of the conical section of the shell to the pressure vessel axis (see Fig 2). When φ exceeds 75°, the shell thickness is to be taken as required for flat heads, see [3.5].

- The minimum thickness of shells having thickness exceeding 1/6 of the external diameter in way of the large end of the cone is subject of special consideration.
- Conical shells may be made of several ring sections of decreasing thickness. The minimum thickness of each section is to be obtained by the formula in a) using for D the maximum diameter of the considered section.
- In general, the junction with a sharp angle between the conical shell and the cylindrical or other conical shell, having different angle of slope, is not allowed if the angle of the generating line of the shells to be assembled exceeds 30°.
- The shell thickness in way of knuckles is subject of special consideration by the Society.

3.3.5 Efficiency

The values of efficiency e to be used in the formulae in [3.3.2], [3.3.3] and [3.3.4] are indicated in Tab 10.

Table 10 : Efficiency of unpierced shells

Case	e
Seamless shells	1
Shells of class 1 vessels (1)	1
Shells of class 2 vessels (with partial radiographic examination of butt-joints)	0,85
Shells of class 2 vessels (without radiographic examination of butt-joints)	0,75
Shells of class 3 vessels	0,6
(1) In special cases the Society reserves the right to take a factor e < 1, depending on the welding procedure adopted for the welded joint.	

3.3.6 Minimum thickness

Irrespective of the value calculated by the formulae in [3.3.2], [3.3.3] [3.3.4], the thickness t of shells is to be not less than one of the following values, as applicable:

- for pressure vessels:
 - in carbon and low alloy steel: $t = 3 + D/1500$ mm
 - in stainless steel and non-ferrous materials: $t = 3$ mm
- for unpierced plates of boilers: $t = 6$ mm
- for boiler cylindrical tube plates: $t = 9,5$ mm.

No corrosion allowance needs to be added to the above values.

For pressure vessels where the cylindrical part is made of a pipe or where corrosion-resistant materials are used, a smaller minimum thickness may be accepted.

Figure 2 : Conic shells

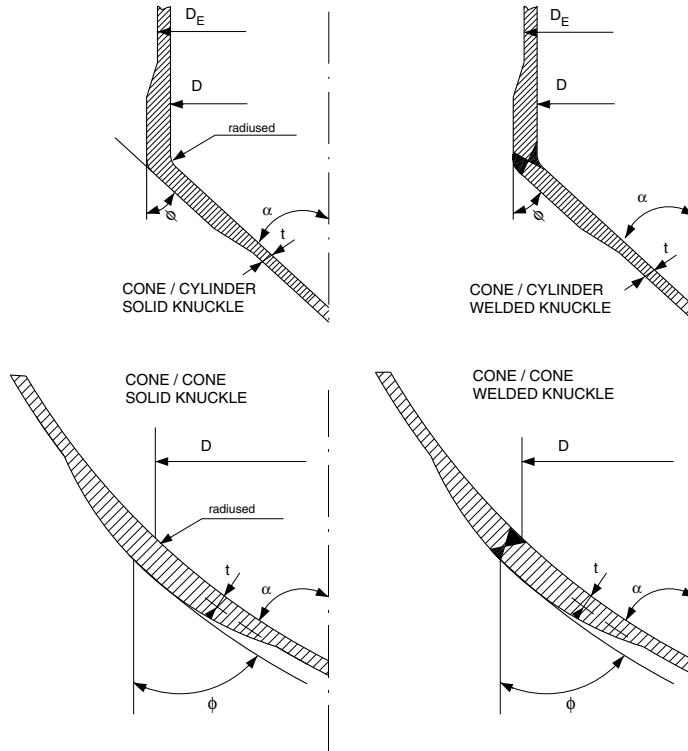

3.3.7 Corrosion allowance

The Society reserves the right to increase the corrosion allowance value in the case of vessels exposed to particular accelerating corrosion conditions. The Society may also consider the reduction of this factor where particular measures are taken to effectively reduce the corrosion rate of the vessel.

3.3.8 Openings in shells

- a) In general, the largest dimensions of the openings in shells are not to exceed:
 - for shells up to 1500 mm in diameter D_E : $1/2 D_E$, but not more than 500 mm
 - for shells over 1500 mm in diameter D_E : $1/3 D_E$, but not more than 1000 mm

where D_E is the vessel external diameter, in mm.

Greater values may be considered by the Society on a case by case basis.

- b) In general, in oval or elliptical openings the ratio major diameter/minor diameter is not to exceed 2.
- c) Openings are considered isolated when the distance between the centres of two adjacent holes in the longitudinal axis is not less than:

$$d + 1,1(D \cdot t_A)^{0,5} \quad \text{or}$$

$$5 d$$

whichever is the lesser,

where:

d : Diameter of the openings, in mm, (if the two openings have different diameter, d is the average diameter).

3.3.9 Openings requiring compensation

The following openings are to be compensated in accordance with the requirements of [3.3.10]:

- a) Isolated openings in shell plates having a diameter, in mm, greater than the smaller of the following values:

$$2,5 t + 70 \quad \text{or}$$

$$\frac{D}{6} \quad \text{or}$$

$$200 \text{ mm}$$

whichever is the lesser, where t is the thickness calculated by the formulae in [3.3.2], [3.3.3] or [3.3.4] as applicable, using an efficiency value e equal to 1 and not adding the corrosion constant.

- b) Non-isolated openings.

3.3.10 Compensation of openings in shells

- a) The compensation area is to be provided in each diametrical direction of the opening and is to be at least equal to the area of the missing material in that direction, corrected as indicated in b).

The area of the missing material in one direction is the width of the opening in that direction multiplied by the required minimum shell thickness calculated by the formulae in [3.3.2], [3.3.3], or [3.3.4], as applicable,

using an efficiency value e equal to 1 without corrosion constant.

- b) The area corresponding to the maximum opening diameter for which compensation is not required may be deducted from the computation of the compensating area to be provided.
- c) Material around the opening outside the width exceeding the opening radius in any direction is not to be included in the calculation of the compensation.
- d) Excess thickness in the shell with respect to the Rule thickness t , calculated as indicated in a), may be considered as contributing to the compensation of the opening for a width not exceeding the opening radius.
- e) Where nozzles are welded to the shell, their excess thickness with respect to the Rule thickness, calculated in accordance with the requirements in [3.6.1], may be considered as contributing to the compensation of the hole for a height h , in mm, equal to:

$$h = [(d_B - 2t_B) \cdot t_B]^{0.5}$$
 where d_B and t_B are the values, in mm, of the outer diameter and thickness of the nozzle, respectively. See also Fig 3.
- f) The sectional area of welds connecting compensating parts may be included in the compensation calculation if they fall inside the area mentioned in a).
- g) If the material of rings, nozzles and reinforcement collars has a lower permissible stress than the shell material, the compensating area is to be proportionally increased.
- h) Fig 3 summarises the compensation criteria described in the above items.
- i) Different arrangements will be specially considered by the Society on a case by case basis.

3.3.11 Cylindrical shells pierced by tube holes

For the minimum thickness of cylindrical shells pierced by tube holes, see [3.7.1].

3.3.12 Covers

- a) Circular, oval and elliptical inspection openings are to be provided with steel covers. Inspection openings on boilers with a diameter not exceeding 150 mm and on pressure vessels may be closed by blind flanges.
- b) The thickness of the opening covers is not to be less than the value t , in mm, given by the following formula:

$$t = 1,22 \cdot a \cdot \left(\frac{pC}{K}\right)^{0.5}$$

where:

- a : The minor axis of the oval or elliptical opening, measured at half width of gasket, in mm
- b : The major axis of the oval or elliptical opening, measured at half width of the gasket, in mm
- C : Coefficient in Tab 11 as a function of the ratio b/a of the axes of the oval or elliptical opening, as defined above. For intermediate values of the ratio b/a , the value of C is to be obtained by linear interpolation.

For circular openings the diameter d , in mm, is to be used in the above formula instead of a .

- c) The thickness obtained by the formula in a) is "net" thickness, as it does not include any corrosion allowance. Unless a greater value is agreed in the vessel contract specification, the thickness obtained by the above formula is to be increased by 1 mm. See also [3.3.7]

Figure 3 : Opening compensation

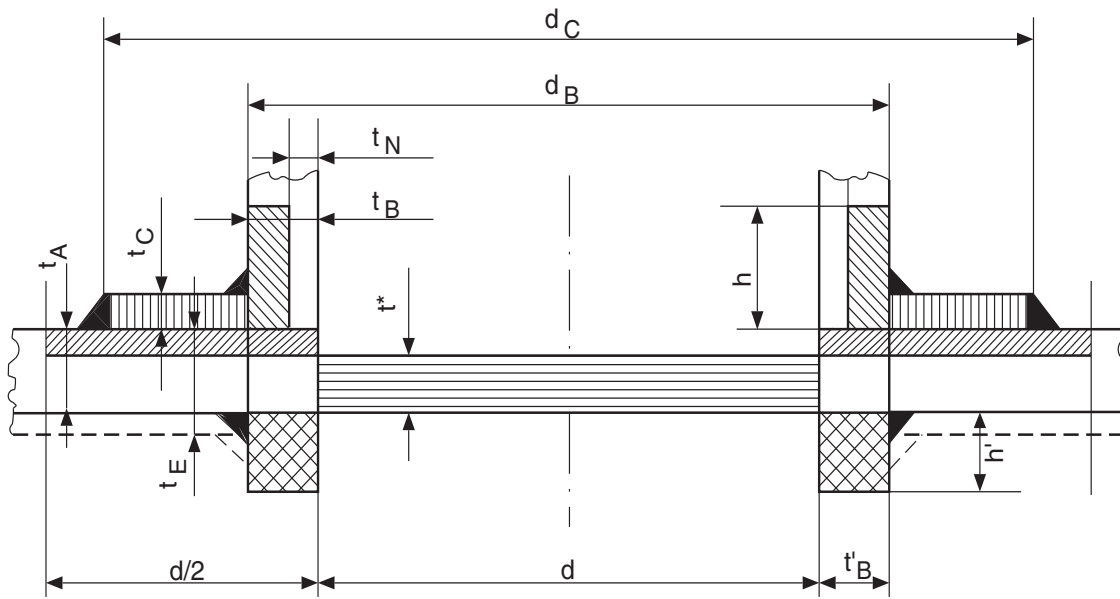

- AREA TO BE COMPENSATED = $(d \text{ minus largest acceptable non-compensated hole diameter}) \cdot t^*$
- EXCESS OF SHELL THICKNESS = $d (t_A - t^*)$
- EXCESS OF NOZZLE THICKNESS = $2h (t_B - t_N)$
- NOZZLE EXTENSION INSIDE SHELL = $2h' \cdot t'_B$
- WELDINGS TOTAL AREA
- COMPENSATION = $(d_C - d_B) t_C$ with $(d_C - d_B) \leq d$

t^* = thickness calculated with $e = 1$ and without corrosion constant

t_E = actual thickness "as built" including corrosion allowance

$$\text{Diagonal hatching} + \text{Cross-hatching} + \text{Cross-hatching} + \text{Solid black} + \text{Vertical hatching} > \text{Vertical hatching}$$

Table 11 : Coefficient C

b/a	1,00	1,05	1,10	1,15	1,20	1,25	1,30	1,40	1,50	1,60
C	0,206	0,220	0,235	0,247	0,259	0,271	0,282	0,302	0,321	0,333

b/a	1,70	1,80	1,90	2,00	2,50	3,00	3,50	4,00	4,50	5,00
C	0,344	0,356	0,368	0,379	0,406	0,433	0,449	0,465	0,473	0,480

3.4 Dished heads subject to pressure on the concave (internal) side

3.4.1 Dished heads for boiler headers

Dished heads for boiler headers are to be seamless.

3.4.2 Dished head profile

The following requirements are to be complied with for the determination of the profile of dished heads (see Fig 4 (a) and (b)).

a) Ellipsoidal heads:

$$H \geq 0,2 D$$

where:

H : External depth of head, in mm, measured from the start of curvature at the base.

D : Outside diameter of the head base, in mm

b) Torispherical heads:

$$R_{IN} \leq D$$

$$r_{IN} \geq 0,1 D$$

$$r_{IN} \geq 3 t$$

$$H \geq 0,18 D$$

where:

R_{IN} : Internal radius of the spherical part, in mm

r_{IN} : Internal knuckle radius, in mm

D : Outside diameter of the head base, in mm

H : External depth of head calculated by the following formula (see Fig 4 (b)):

$$H = R_E - [(R_E - 0,5 D) \cdot (R_E + 0,5 D - 2 r_E)]^{0,5}$$

where:

R_E : External radius of the spherical part, in mm

r_E : External knuckle radius, in mm.

3.4.3 Required thickness of solid dished heads

a) The minimum thickness of solid (not pierced) hemispherical, torispherical, or ellipsoidal unstayed dished heads, subject to pressure on the concave (internal) side, is to be not less than the value t , in mm, calculated by the following formula:

$$t = \frac{pDC}{2Ke}$$

where:

C : Shape factor, obtained from the graph in Fig 5, as a function of H/D and t/D

for other symbols, see [3.3.2].

b) The thickness obtained by the formula in a) is “net” thickness, as it does not include any corrosion allowance. Unless a greater value is agreed in the vessel contract specification, the thickness obtained by the above formula is to be increased by 0.75 mm. See also [3.3.7].

3.4.4 Composed torispherical heads

a) Torispherical heads may be constructed with welded elements of different thickness (see Fig 6).

b) Where a torispherical head is built in two sections, the thickness of the torispherical part is to be obtained by the formula in [3.4.3], while the thickness of the spherical part may be obtained by the formula in [3.3.3].

c) The spherical part may commence at a distance from the knuckle not less than:

$$0,5 \cdot (R_{IN} \cdot t)^{0,5}$$

where:

R_{IN} : Internal radius of the spherical part, in mm

t : Knuckle thickness, in mm

3.4.5 Minimum thickness

Irrespective of the value calculated in [3.4.3] and [3.4.4] the thickness t of dished heads is not to be less than:

- 3 + D/1500 mm for normal pressure vessels in carbon and low alloy steel
- 3 mm for normal pressure vessels in stainless steel and non-ferrous materials
- 6 mm for boiler pressure vessels

No corrosion allowance needs to be added to the above values.

3.4.6 Connection of heads to cylindrical shells

The heads are to be provided, at their base, with a cylindrical skirt not less than $2t$ in length and with a thickness in no case less than the Rule thickness of a cylindrical shell of the same diameter and the same material, calculated by the formula given in [3.3.2] using the same efficiency factor e adopted for calculation of the head thickness. Fig 7 and Fig 8 show typical admissible attachments of dished ends to cylindrical shells.

In particular, hemispherical heads not provided with the above skirt are to be connected to the cylindrical shell if the latter is thicker than the head, as shown in Fig 8.

Other types of connections are subject of special consideration by the Society.

Figure 4 : Dished head profiles

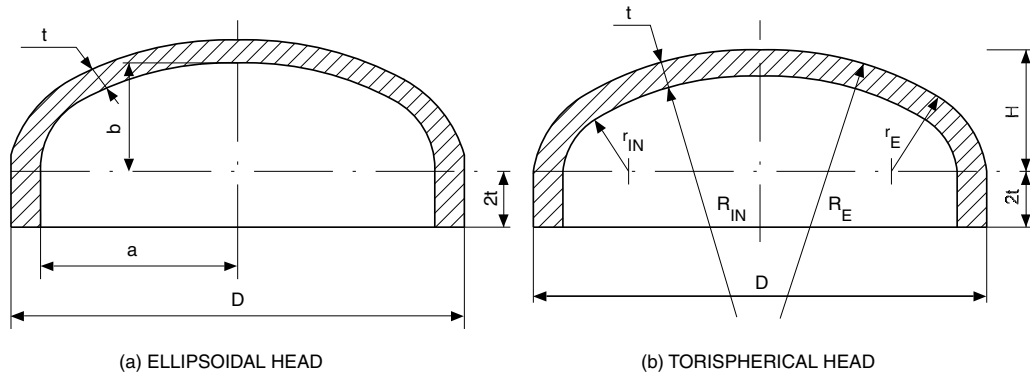

Figure 5 : Shape factor for dished heads

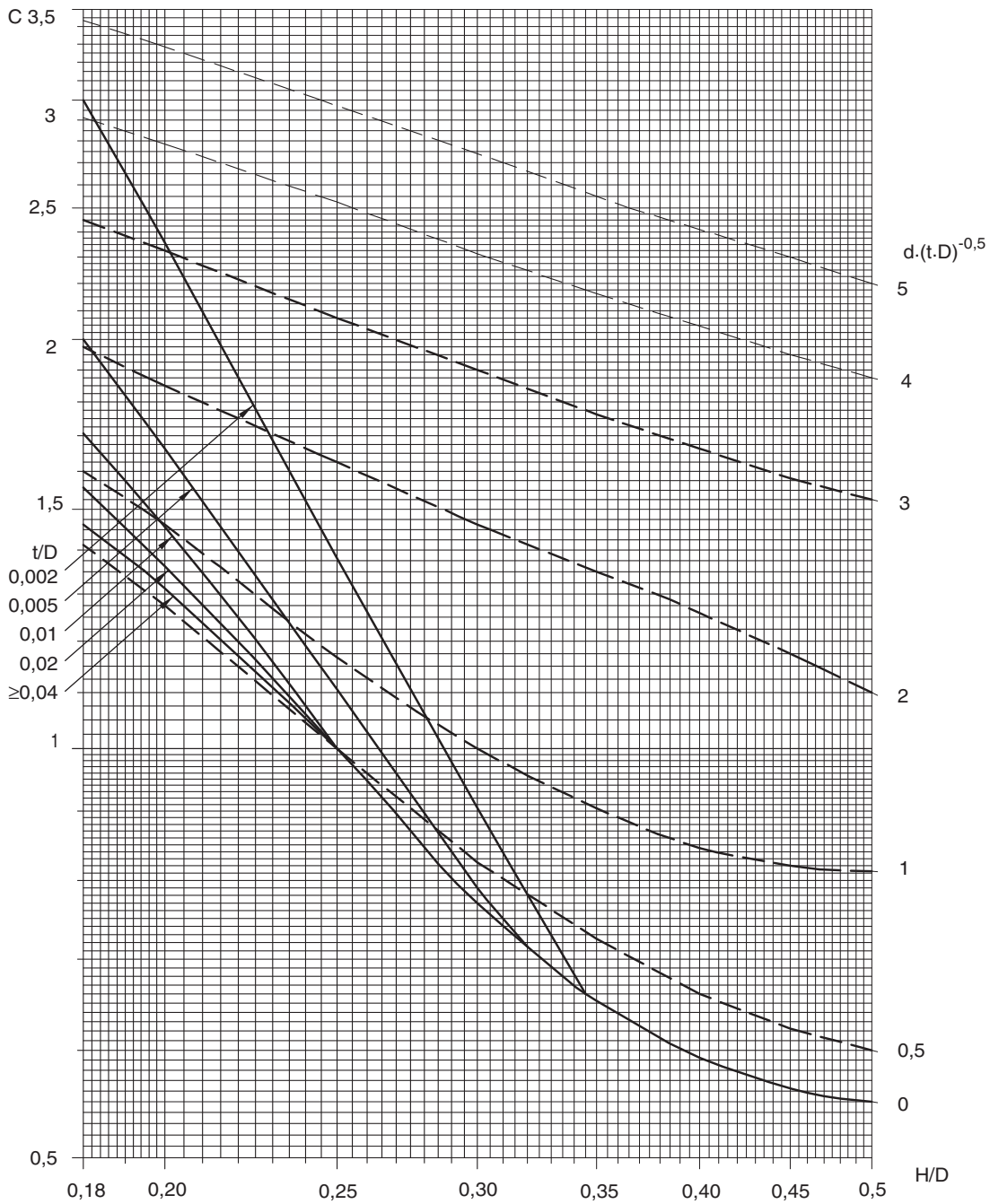
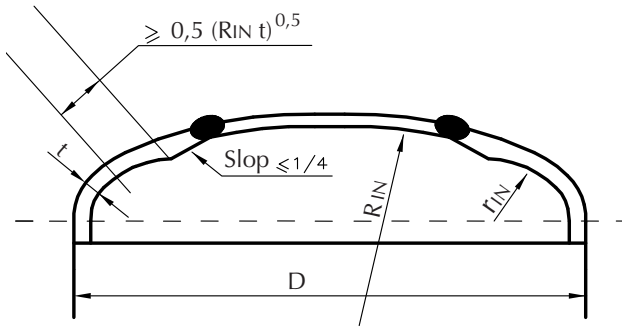

Figure 6 : Composed torispherical head



3.4.7 Dished heads with openings

- a) The openings in dished heads may be circular, elliptical or oval.
- b) The largest diameter of the non-compensated opening is not to exceed one half of the external diameter of the head.

- c) The opening is to be so situated that its projection, or its reinforcement projection in the case of compensated openings, is completely contained inside a circle having its centre at the centre of the head and a diameter of 0,8D, D being the external diameter of the head (see Fig 9). However, a small reinforced opening for drainage may be accepted outside the indicated area.
- d) In the case of non-compensated openings (for this purpose, flanged openings are also to be considered as non-compensated), the head thickness is not to be less than that calculated by the formula in [3.4.3] using the smallest of the shape factors C obtained from the graph in Fig 5 as a function of:

$$H/D \text{ and } t/D \text{ or } H/D \text{ and } d.(t.D)^{-0.5},$$

where d is the diameter of the largest non-compensated opening in the head, in mm. For oval and elliptical openings, d is the width of the opening in way of its major axis.

Figure 7 : Typical attachment of dished heads to cylindrical shells

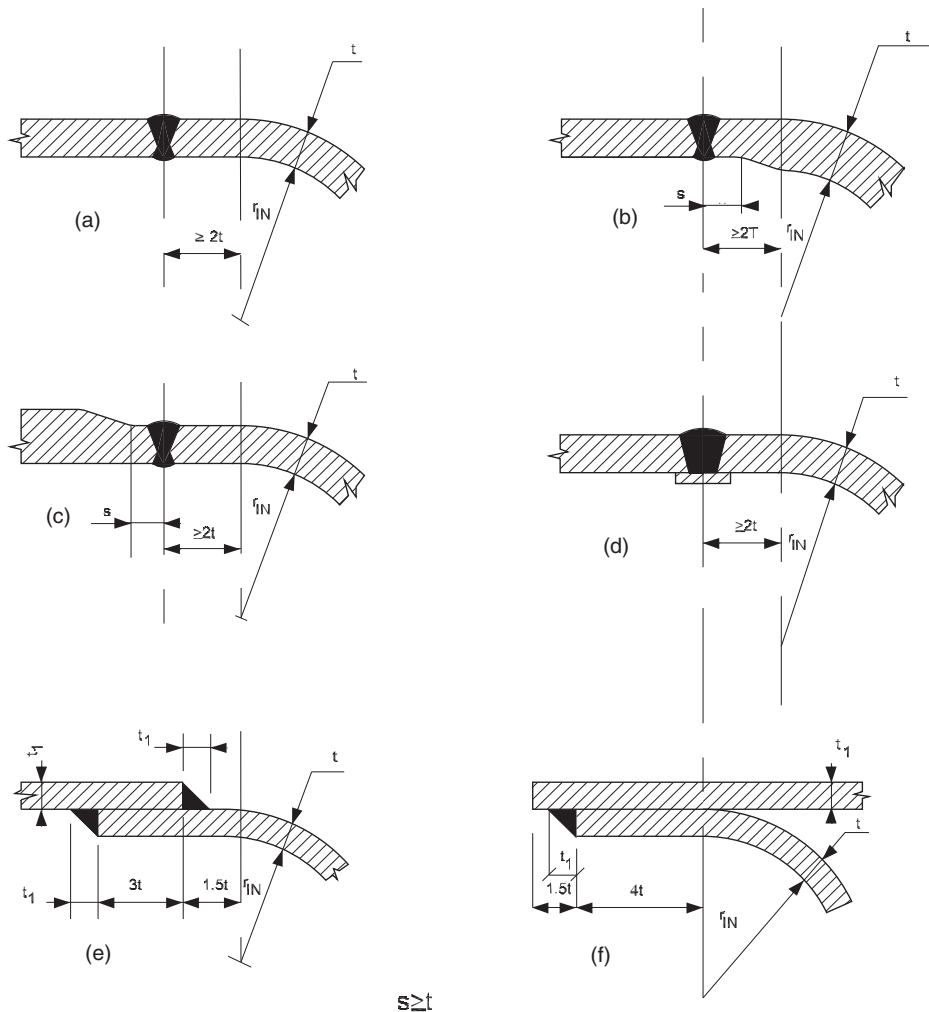

Types shown in (a), (b) and (c) are acceptable for all pressure vessels.

Type shown in (d) is acceptable for class 2 and class 3 pressure vessels.

Types shown in (e) and (f) are acceptable for class 3 pressure vessels only.

- e) In all cases the diameter D of the head base, the head thickness t and the diameter d of the largest non-compensated opening are to be such as to meet the following requirements:
- The position of non-compensated openings in the heads is to be as shown in Fig 9
 - For flanged openings, the radius r of the flanging (see Fig 9) is not to be less than 25 mm
 - The thickness of the flanged part may be less than the Rule thickness.

3.4.8 Compensated openings in dished heads

- a) Where openings are cut in dished heads and the proposed thickness of the head is less than that calculated by the formula in [3.4.3], the openings are to be compensated.
- b) Fig 22, Fig 23, Fig 24 and Fig 25 show typical connections of nozzles and compensating rings.
- c) The opening is considered sufficiently compensated when the head thickness t is not less than that calculated in accordance with [3.4.3] and using the shape-factor C obtained from the graph in Fig 5 using the value:

$$\left(d - \frac{A}{t}\right) \cdot (tD)^{-0.5}$$

in lieu of:

$$d \cdot (tD)^{-0.5}$$

where:

- A : Area, in mm^2 , of the total transverse section of the compensating parts
- t : Actual thickness of the head, in mm, in the zone of the opening under consideration

- d) When $A/t > d$, the coefficient C is to be determined using the curve corresponding to the value:
 $d \cdot (tD)^{-0.5} = 0$
- e) If necessary, calculations are to be repeated.

3.4.9 Compensation criteria

In the evaluation of the area A , the following is also to be taken into consideration:

- a) The material that may be considered for compensating an opening is that located around the opening up to a distance l from the edge of the opening. The distance l , in mm, is the lesser obtained from the following formulae:

$$l = 0,5 d$$

$$l = (2 R_{IN} t)^{0.5}$$

where:

- d : Diameter of the opening, in mm
- R_{IN} : Internal radius of the spherical part, in mm, in the case of hemispherical or torispherical heads

In the case of ellipsoidal heads, R_{IN} is to be calculated by the following formula (see Fig 4 a):

$$R_{IN} = \frac{[a^4 - x^4(a^2 - b^2)]^{3/2}}{a^4 b}$$

where;

- a : Half the major axis of the elliptical meridian section of the head, in mm
- b : Half the minor axis of the above section, in mm
- x : Distance between the centre of the hole and the rotation axis of the shell, in mm.

- b) In the case of nozzles or pads welded in the hole, the section corresponding to the thickness in excess of that required is to be considered for the part which is subject to pressure and for a depth h , in mm, both on the external and internal sides of the head, not greater than:

$$(d_B \cdot t_B)^{0.5}$$

where d_B and t_B are the diameter of the opening and the thickness of the pad or nozzle, in mm, respectively. See also Fig 3.

- c) The area of the welding connecting nozzle and pad reinforcements may be considered as a compensating section.
- d) If the material of reinforcement pads, nozzles and collars has a permissible stress lower than that of the head material, the area A , to be taken for calculation of the coefficient C , is to be reduced proportionally.

3.5 Flat heads

3.5.1 Unstayed flat head minimum thickness

- a) The minimum thickness of unstayed flat heads is not to be less than the value t , in mm, calculated by the following formula:

$$t = D \left(\frac{100p}{CK} \right)^{0.5}$$

where:

- p : Design pressure, in MPa
- K : Permissible stress, in N/mm^2 , obtained as specified in [3.2]
- D : Diameter of the head, in mm. For circular section heads, the diameter D is to be measured as shown in Fig 10 and Fig 11 for various types of heads. For rectangular section heads, the equivalent value for D may be obtained from the following formula:

$$D = a \left[3,4 - 2,4 \left(\frac{a}{b} \right) \right]^{0.5}$$

a and b being the smaller and larger side of the rectangle, respectively, in mm.

- C : The values given below, depending on the various types of heads shown in Fig 10 and Fig 11:

Fig 10(a): $C = 400$ for circular heads

Fig 10(b): $C = 330$ for circular heads

Fig 10(c): $C = 350$ for circular heads

Fig 10(d): $C = 400$ for circular heads and $C = 250$ for rectangular heads

Fig 10(e): $C = 350$ for circular heads and
 $C = 200$ for rectangular heads

Fig 10(f): $C = 350$ for circular heads

Fig 10(g): $C = 300$ for circular heads

Fig 10(h): $C = 350$ for circular heads and
 $C = 200$ for rectangular heads

Fig 11(i): $C = 350$ for circular heads and
 $C = 200$ for rectangular heads

Fig 11(j): $C = 200$ for circular heads

Fig 11(k): $C = 330$ for circular heads

Fig 11(l): $C = 300$ for circular heads

Fig 11(m): $C = 300$ for circular heads

Fig 11(n): $C = 400$ for circular heads

Fig 11(o): $C =$ value obtained from the following formula, for circular heads:

$$C = \frac{100}{0,3 + \frac{1,9Fh}{pD^3}}$$

where:

h : Radial distance, in mm, from the pitch centre diameter of bolts to the circumference of diameter D , as shown in Fig 11(o).

F : Total bolt load, in N, to be taken as the greater of the following values F_1 and F_2 :

$$F_1 = 0,785 D p (D + m b)$$

$$F_2 = 9,81 y D b$$

with:

b : Effective half contact width of the gasket, in mm, calculated as follows:

$$b = 0,5 N \quad \text{for } N < 13 \text{ mm, and}$$

$$b = 1,8 N^{0,5} \quad \text{for } N \geq 13 \text{ mm}$$

where N is the geometric contact width of the gasket, in mm, as indicated in Fig 11(o)

m, y : Adimensional coefficients, whose values are given in Tab 12, depending on the type of gasket.

The adoption of one of the above-mentioned heads is subject to the Society's approval depending upon its use. Types of heads not shown in Fig 10 and Fig 11 will be the subject of special consideration by the Society.

- b) The thickness obtained by the formula in a) is "net" thickness, as it does not include any corrosion allowance. Unless a greater value is agreed in the vessel contract specification, the thickness obtained by the above formula is to be increased by 1 mm. See also [3.3.7].

Figure 8 : Connection of hemispherical head to the cylindrical shell

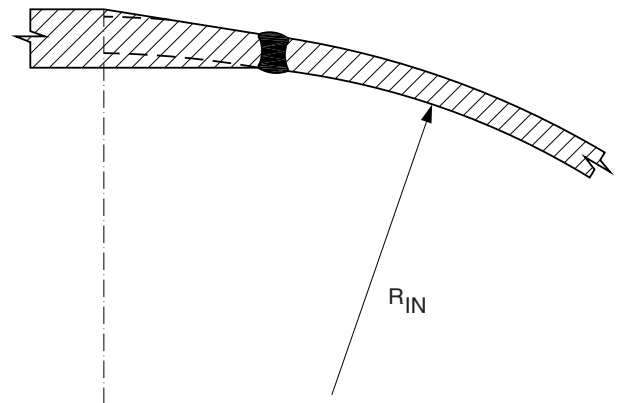
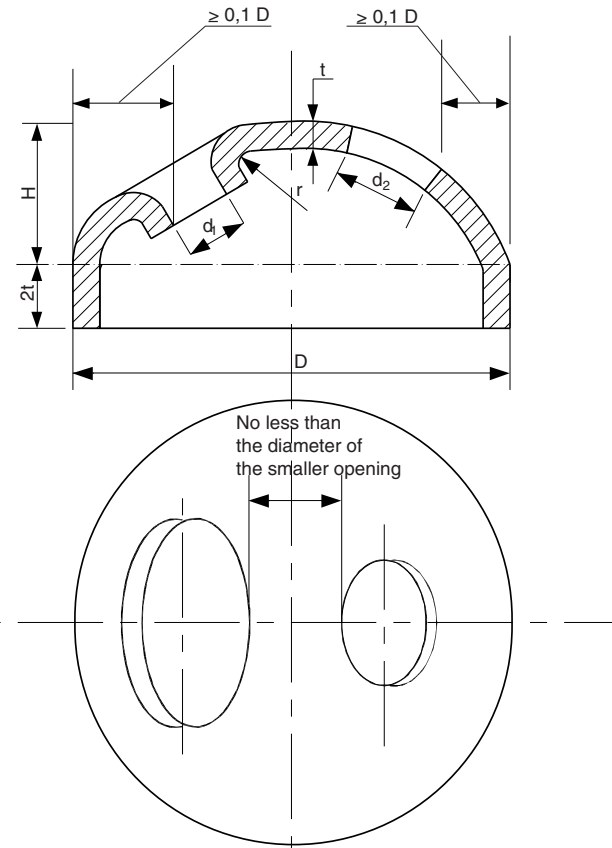

Figure 9 : Openings on dished heads



3.5.2 Stayed flat head minimum thickness

For the minimum thickness of stayed flat heads, see [3.8.4].

3.5.3 Compensation of openings in flat plates

Openings in flat plates for inspection purposes or for connection of fittings are to be compensated by reinforcement collars or by flanges.

In the latter case, the depth h of the flange, in mm, measured from the outer surface, is not to be less than the value obtained from the following formula:

$$h = (t \cdot d_M)^{0,5}$$

where t and d_M are the values, in mm, of the plate thickness and of the minimum width of the opening.

Table 12 : Coefficients m and y

Type of gasket	m	y
Self-sealing, metal or rubber (e.g. O-ring)	0	0
Rubber with cotton fabric	10	0,88
Rubber with reinforcing fabric with or without metal wire:		
- 3 layers	18	4,85
- 2 layers	20	6,4
- 1 layers	22	8,2
Synthetic fibre with suitable binders:		
- 3 mm thick	16	3,5
- 1,5 mm thick	22	8,2
Organic fibre	14	2,4
Metal spiral lined with synthetic fibre:		
- Carbon Steel	20	6,4
- Stainless Steel	24	9,9
Synthetic fibre with plain metal lining:		
- Copper	28	14,0
- Iron	30	16,8
- Stainless steel	30	20,0
Solid metal:		
- Copper	38	28,7
- Iron	44	39,8
- Stainless steel	52	57,5

3.6 Nozzles

3.6.1 Thickness

- a) The thickness t , in mm, of nozzles attached to shells and headers of boilers is not to be less than:

$$t = \frac{d_E}{25} + 2,5$$

where d_E is the outside diameter of nozzle, in mm.

The thickness of the nozzle is, however, to be not less than the thickness required for the piping system attached to the vessel shell calculated at the vessel design pressure, and need not to be greater than the thickness of the shell to which it is connected.

- b) The thickness of the nozzle attached to shells and headers of other pressure vessels is not to be less than the thickness required for the piping system attached to the vessel shell calculated at the vessel design pressure, and need not be greater than the thickness of the shell to which it is connected.
- c) Where a branch is connected by screwing, the thickness of the nozzle is to be measured at the root of the thread.

3.6.2 Nozzle connection to vessel shell

- a) In general, the axis of the nozzle is not to form an angle greater than 15° with the normal to the shell.
- b) Fig 22, Fig 23, Fig 24 and Fig 25 show some typical acceptable connections of nozzles to shells. Other types of connections will be considered by the Society on a case by case basis.

3.7 Water tube boilers

3.7.1 Drums and headers

The scantlings of cylindrical drums and headers pierced by pipe holes are to be obtained by the applicable formulae in [3.3], [3.4], [3.5], [3.7.2] and [3.7.3].

Figure 10 : Types of unstayed flat heads (1)

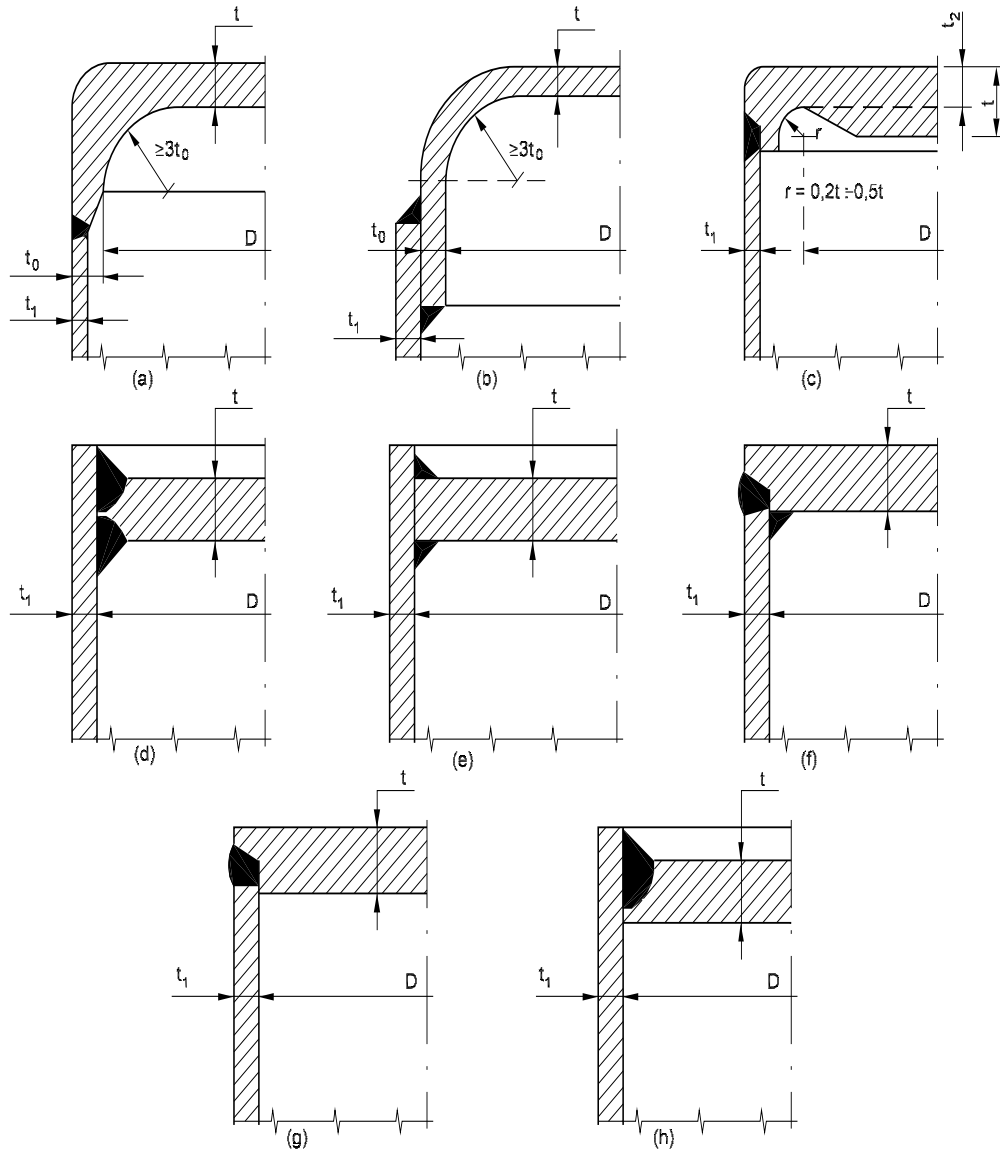
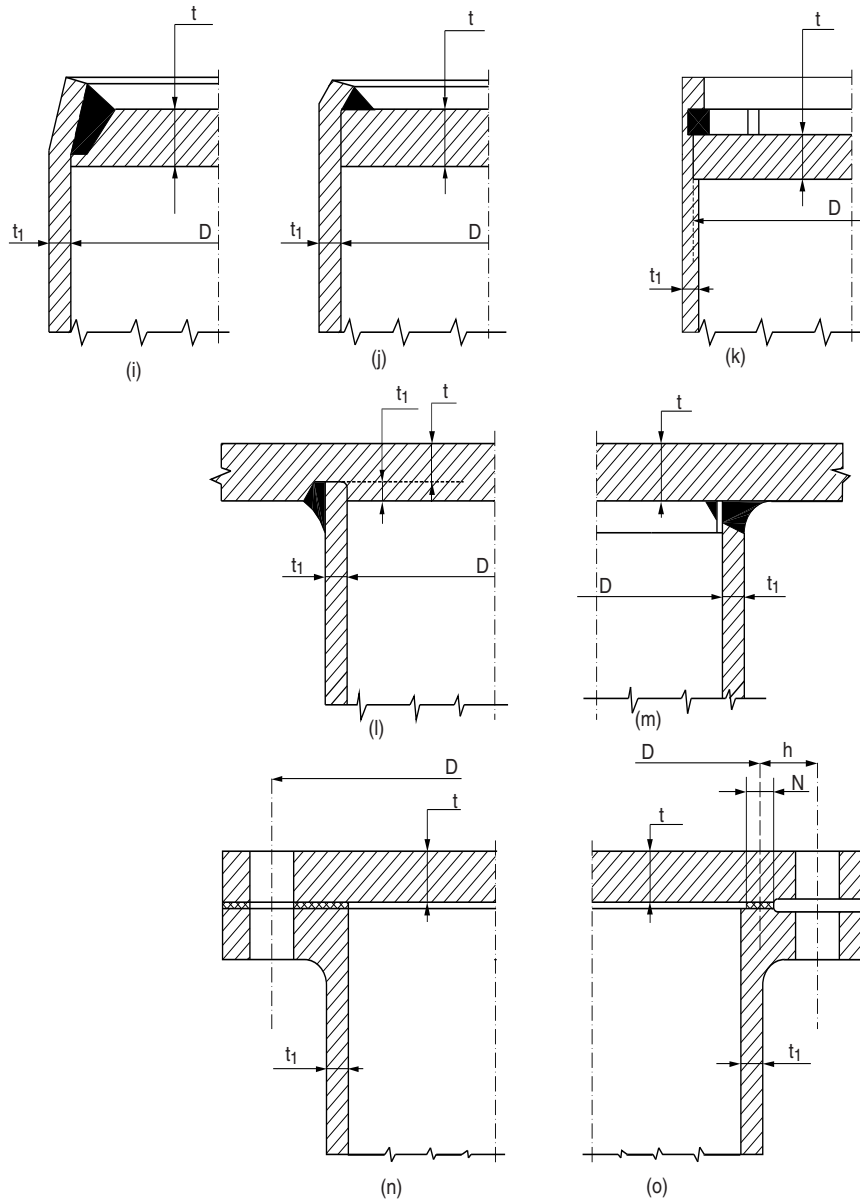

Figure 11 : Types of unstayed flat heads (2)



3.7.2 Efficiency factor of tube holes in cylindrical tube plates

The efficiency factor *e* of pipe holes in cylindrical shells pierced by tube holes is to be determined by direct calculation or by another suitable method accepted by the Society. In the case of cylindrical holes of constant diameter and radial axis, the efficiency factor *e* may be determined by the following formula (see Fig 12):

$$e = \frac{1}{\frac{s}{s-d} \cdot (1 - (0,5 \cdot \sin^2 \alpha)) + m \cdot \sin 2\alpha}$$

where:

s : Pitch of the hole row considered, in mm

- d* : Diameter of holes, in mm. The hole diameter *d* may be reduced by the amount A/t_A , where *A* is the compensating area, in mm², of nozzle and welds (see [3.3.9] and Fig 3).
- α* : Angle between the axis of hole row considered and the axis of the cylinder (*α*=0° if the hole row is parallel to the cylinder generating line; *α*=90° for circumferential hole row).
- m* : Coefficient depending upon the ratio *d/s*, as obtained from Tab 13. For intermediate values of *d/s*, the value of *m* is to be obtained by linear interpolation.

The value of *e* actually used is to be the smallest calculated value for either longitudinal, diagonal or circumferential rows of holes.

Figure 12 : Hole pattern in cylindrical shells

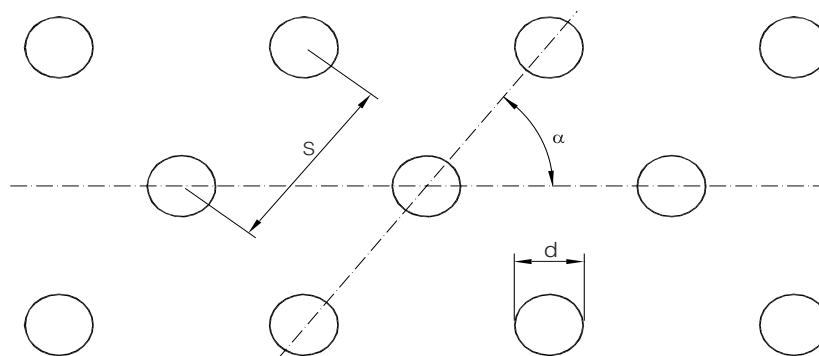

Table 13 : Coefficient m

d/s	0,30	0,35	0,40	0,45	0,50	0,55	0,60	0,65	0,70	0,75	0,80
m	0,137	0,175	0,220	0,274	0,342	0,438	0,560	0,740	1,010	1,420	2,060

3.7.3 Welded shells with tube holes and efficiency factor of different hole patterns

Where shells have welding butts and/or different groups of hole patterns, the value to be assumed for the efficiency e in the formulae is the minimum of the values calculated separately for each type of welding (as per [3.3.5]) and for each configuration of holes (as per [3.7.2]).

3.7.4 Rectangular section headers

- a) For seamless type headers of rectangular section design, the wall thickness t , in mm, in way of corner fillets and the thickness t_1 , in mm, of any drilled wall is not to be less than those given by the following formulae, as appropriate (see Fig 13):

$$t = \left(\frac{100pM_1}{K} \right)^{0.5}$$

$$t_1 = \left(\frac{100pM_2}{eK} \right)^{0.5}$$

where (see also Fig 13):

- t : Wall thickness at the corners, in mm
 t_1 : Thickness of drilled wall, in mm
 p : Design pressure, in MPa
 K : Permissible stress, in N/mm², obtained as specified in [3.2]
 a : Internal half width of the header, in a direction parallel to the wall under consideration, in mm
 b : Internal half width of the header, in a direction normal to the wall under consideration, in mm
 c : Distance between the axis of the hole row considered and the centreline of the header wall, in mm
 e : Efficiency factor of holes in the wall, determined by the following formulae:

$$e = \frac{s-d}{s} \quad \text{for } d < a$$

$$e = \frac{s-0,67d}{s} \quad \text{for } a \leq d < 1,3a$$

$$e = \frac{s-0,33d}{s} \quad \text{for } d \geq 1,3a$$

where:

s : Pitch of the holes, in mm, of the longitudinal or diagonal row under consideration. For a staggered pattern of holes the pitch of the diagonal row is to be considered

d : Diameter of the holes, in mm

M_1 : Coefficient to be calculated by the following formula:

$$M_1 = \frac{a^2 + b^2 - ab}{50}$$

M_2 : Coefficient (to be taken always positive) to be calculated by one of the following formulae, as appropriate:

For a non-staggered pattern of holes:

$$M_2 = \frac{b^2 - \frac{1}{2}a^2 - ab + \frac{3}{2}c^2}{50}$$

For a staggered pattern of holes:

$$M_2 = \frac{b^2 - \frac{1}{2}a^2 - ab}{50} \cos \alpha$$

where α is the angle between the axis of the diagonal row of the holes under consideration and the axis of the header, in the case of a staggered pattern of holes.

- b) The thickness obtained by the formulae in a) is "net" thickness, as it does not include any corrosion allowance. Unless a greater value is agreed in the vessel contract specification, the thickness obtained by the above formula is to be increased by 1,5 mm. See also [3.3.7].

Figure 13 : Rectangular section headers

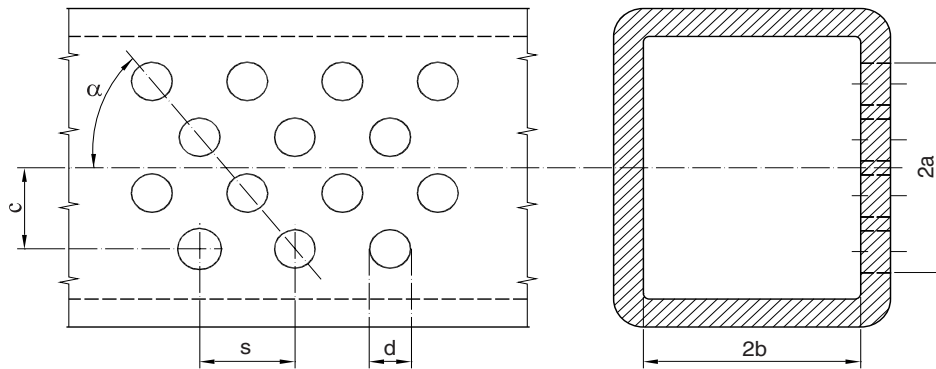

3.7.5 Water tubes, superheaters and economiser tubes

- a) The thickness of tubes of evaporating parts, economisers and superheaters exposed to gases which are subject to internal pressure is not to be less than the value t , in mm, given by the following formula:

$$t = \frac{pd}{2K + p} + 0,3$$

where:

- p : Design pressure, in MPa
- K : Permissible stress, in N/mm^2 , obtained as specified in [3.2]
- d : Outside diameter of tube, in mm

However, irrespective of the value calculated by the formulae in a), the thickness t of tubes is not to be less than the values given in Tab 14.

- b) The values of t determined by the above-mentioned formula are to be considered as theoretical values for straight tubes, not taking account of the manufacturing tolerance. Where the tubes are not precise pipes, the thickness calculated by the formula in a) is to be increased by 12,5% to take into account the manufacturing tolerance. For bent tubes, the thickness of the thinner part in way of the bend is not to be less than that given by the formula.
- c) Whenever abnormal corrosion and erosion may occur during service, the corrosion constant of 0,3 in the formula in a) may be increased to the satisfaction of the Society.
- d) The thickness of tubes which form an integral part of the boiler and which are not exposed to combustion gases is to comply with the requirements for steam pipes (see Sec 10, [15]).

3.8 Additional requirements for vertical boilers and cylindrical boilers (fire tube boilers)

3.8.1 Shells of vertical boilers and cylindrical boilers

The scantlings of the shells of vertical boilers and cylindrical boilers are to be determined in accordance with [3.3].

Table 14 : Minimum thickness of water tubes

Outside diameter in mm	Minimum thickness in mm of tubes subject to internal pressure of cylindrical boilers and water tube boilers having the feed water system	
	Closed type or open type, if equipped with suitable devices for reducing the oxygen concentration in the water	Open type, not equipped with suitable devices for reducing the oxygen concentration in the water
< 38	1,8	2,9
38 - 48,3	2,0	2,9
51 - 63,5	2,4	2,9
70	2,6	3,2
76,1 - 88,9	2,9	3,2
101,6 - 127	3,6	-

3.8.2 Ends of vertical boilers

- a) The minimum thickness of the dished ends forming the upper part of vertical boilers and subject to pressure on their concave face is to be determined in accordance with [3.4].
- b) When the end is supported in its centre by an uptake, the minimum thickness t , in mm, is to be calculated with the following formula:

$$t = 0,77 \cdot \frac{pR_i}{K}$$

where:

- p : Design pressure, in MPa
- K : Permissible stress, in N/mm^2 , obtained as specified in [3.2]
- R_i : Radius of curvature at the centre of the end measured internally. R_i is not to exceed the external diameter of the shell

- c) The thickness obtained by the formula in b) is "net" thickness, as it does not include any corrosion allowance. Unless a greater value is agreed in the vessel con-

tract specification, the thickness obtained by the above formula is to be increased by 0,7 mm. See also [3.3.7].

- d) For ends supported by an uptake at their centre, the corner radius measured internally is not to be less than 4 times the end thickness or 65 mm, whichever is the lesser and the inside radius of curvature on the flange to uptake is not to be less than twice the end thickness or 25 mm, whichever is the lesser.

3.8.3 Ends of cylindrical boilers

The minimum thickness of the dished and/or unstayed flat ends of the cylindrical boilers is to be determined in accordance with [3.4] and/or [3.5], as applicable.

3.8.4 Stayed flat head minimum thickness

- a) The thickness of stayed flat heads, or of heads supported by flanges, is not to be less than the value t , in mm, given by the following formula:

$$t = D \left[\frac{100p}{CC_1K(1+C_2B^2)} \right]^{0.5}$$

where:

- B : t_1/t = Ratio of the thickness of the large washer or doubler, where fitted, to the thickness of the plate. The value of B is to be taken between 0,67 and 1
- K : Permissible stress, in N/mm², obtained as specified in [3.2]
- C : C = 1 when the plate is not exposed to flame
C = 0,88 when the plate is exposed to flame
- C₁ : C₁ = 462 when the plate is supported by welded stays
C₁ = 704 for plates supported by flanges or equivalent
- C₂ : C₂ = 0 when no doublers are fitted
C₂ = 0,85 when a complete doubling plate is fitted, adequately joined to the base plate.

The value of D is to be in accordance with the following provisions:

- In the parts of the flat heads between the stays:

D : Diameter, in mm, of the largest circle which can be drawn through the centre of at least three stays without enclosing any other stay, where the stays are not evenly spaced (see Fig 14); or $(a^2+b^2)^{0.5}$ where the stays are evenly spaced, considering the most unfavourable condition,

where:

a : Distance between two adjacent rows of stays, in mm

b : Pitch of stays in the same row, in mm.
- In the parts of the flat heads between the stays and the boundaries, where flat heads are generally supported by flanges or shapes, or connected to other parts of the boiler:

D : Diameter, in mm, of the largest circle which can be drawn through not less

than three points of support (stay centres or points of tangency of the circle with the contour line). To this end, the contour of the part under consideration is to be drawn at the beginning of the flanging or connection curve if its inside radius does not exceed 2,5 times the thickness of the plate, or, where such radius is greater, at the above-mentioned distance (of 2,5 times the thickness of the plate) from the ideal intersection with other surfaces (see Fig 14).

- b) When applying the formulae for calculation of thickness of heads covered by this sub-article, the position of plates in the most unfavourable condition is to be considered.
- c) Where various types of supports are provided, the value of C₁ should be the arithmetic mean of the values of C₁ appropriate to each type of support.
- d) The thickness obtained by the formulae in a), is "net" thickness, as it does not include any corrosion allowance. Unless a greater value is agreed in the vessel contract specification, the thickness obtained by the above formula is to be increased by 1 mm. See also [3.3.7].

3.8.5 Furnaces

- a) In general, the minimum thickness of furnaces is to be calculated in accordance with the requirements of a recognised Standard for pressure vessels subject to external pressure accepted by the Society.
- b) However, the minimum thicknesses of furnaces and cylindrical ends of combustion chambers of fire tube boilers are to be not less than the value t given by the appropriate formula in [3.8.6], [3.8.7] and [3.8.8].
- c) The thickness of furnaces is not to be less than 8 mm and the stays are to be spaced such that the thickness does not exceed 22 mm.
- d) All the thicknesses obtained for furnaces by the formulae in [3.8.6], [3.8.7], [3.8.8], [3.8.9] and [3.8.10] are "net" thicknesses, as they do not include any corrosion allowance. Unless a greater value is agreed in the vessel contract specification, the thicknesses obtained by the above formulae are to be increased by 1 mm. See also [3.3.7].

3.8.6 Plain furnaces with reinforcing rings and similar, and bottoms of combustion chambers

The minimum thickness t , in mm, of plain furnaces with reinforcing rings and bottoms of combustion chambers is not to be less than the value given by the following equation:

$$t = \frac{pD_E}{0,28R_m} + \frac{L}{286}$$

where:

- p : Design pressure, in MPa
- R_m : Ultimate tensile strength, in N/mm²
- D_E : External diameter of the furnace, in mm
- L : Length of furnace or spacing of reinforcing rings, in mm.

Figure 14

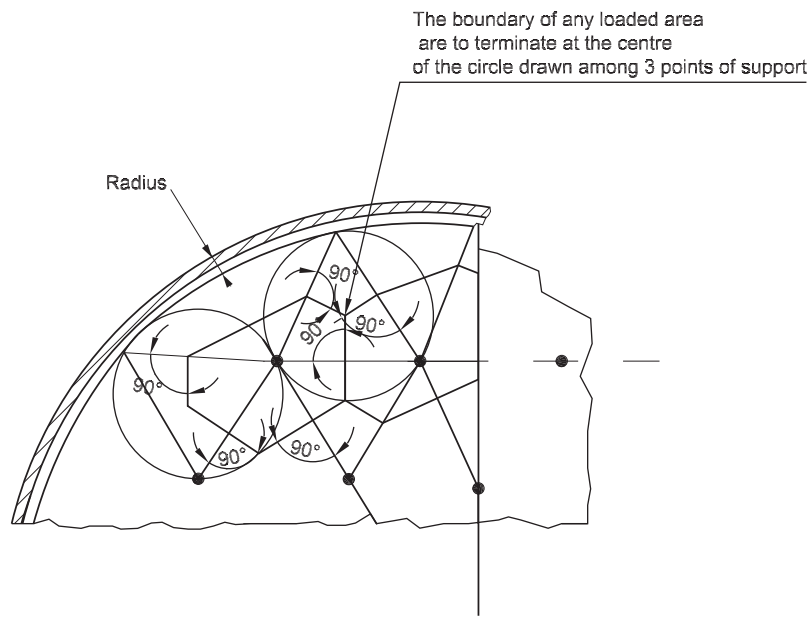

3.8.7 Corrugated or rib-reinforced furnaces

The minimum thickness t , in mm, of corrugated or rib-reinforced furnaces is to be not less than the value given by the following equation:

$$t = \frac{pD_E}{CR_m}$$

where:

D_E : Diameter of the furnace at the bottom of the corrugation or at the outside of the plain portion, in mm.

C : 0,26 for corrugated furnaces
0,28 for furnaces with rib reinforcements.

For the meaning of other symbols, see [3.8.6].

3.8.8 Hemispherical furnaces

The minimum thickness t , in mm, of hemispherical furnaces is to be not less than the value given by the following equation:

$$t = \frac{pD_E}{120}$$

For the meaning of the symbols, see [3.8.6].

3.8.9 Flat tube plates in tube bundles

The thickness of the parts of flat tube plates contained in the tube bundle and supported by stay tubes is not to be less than the value t , in mm, given by the following formula:

$$t = s \left(\frac{p}{2,8K} \right)^{0,5}$$

where:

- p : Design pressure, in MPa
- K : Permissible stress, in N/mm², obtained as specified in [3.2]
- s : Pitch of stay tubes, taken as the greatest mean pitch of the stay tubes supporting a quadrilateral portion of the plate, in mm.

3.8.10 Flat tube plates of combustion chamber in vertical boilers

Where tube plates contained in the tube bundle are simultaneously subject to compression due to the pressure in the combustion chamber, their thickness, as well as complying with the requirements in [3.8.9] is not to be less than the value t , in mm, given by the following formula:

$$t = \frac{pl_s1}{1,78(s_1 - d)K}$$

where:

- l : Depth of the combustion chamber, in mm
- s_1 : Horizontal pitch of tubes, in mm
- d : Inside diameter of plain tubes, in mm

For the meaning of other symbols, see [3.8.9]

3.8.11 Tube plates outside tube bundles

For those parts of tube plates which are outside the tube bundle, the formula in [3.8.4] is to be applied, using the following coefficients C_1 and C_2 :

$$C_1 = 390$$

$$C_2 = 0,55$$

Doublers are only permitted where the tube plate does not form part of a combustion chamber.

3.8.12 Tube plates not supported by stays

Flat tube plates which are not supported by stay tubes (e.g. in heat exchangers), are subject of special consideration by the Society (see also [3.10.1]).

3.8.13 Stay and stay tube scantlings

a) The diameter of solid stays of circular cross-section is not to be less than the value d calculated by the following formula:

$$d = \left(\frac{pA}{K} \right)^{0,5}$$

where:

- d : Minimum diameter, in mm, of the stay throughout its length.
- A : Area supported by the stay, in mm²
- K : $R_m / 7$
- R_m : Minimum ultimate tensile strength of the stay material, in N/mm².

The cross section of tube stays is to be equivalent to that of a solid stay supporting the same area, whose diameter is calculated by the above formula.

Stays which are not perpendicular to the supported surface are to be of an adequately increased diameter depending on the component of the force normal to the plate.

- b) Where articulated stays are used, articulation details are to be designed assuming a safety factor for articulated elements not less than 5 with respect to the value of R_m and a wear allowance of 2 mm.

The articulation is to be of the fork type and the clearance of the pin in respect of the holes is not to exceed 1,5 mm. The pin is to bear against the jaws of the fork and its cross-sectional area is not to be less than 80% of the cross-sectional area of the stay. The width of material around the holes is not to be less than 13 mm.

- c) Where stays are flanged for joining to the plate, the thickness of the flange is not to be less than one half the diameter of the stay.
- d) For welded connections of stays to tube plates, see Fig 29.

3.8.14 Stay and stay tube construction

- a) In general, doublers are not to be fitted in plates exposed to flame.
- b) As far as possible, stays are to be fitted perpendicularly to the supported surface.
- c) Long stays in double front boilers and, in general, stays exceeding 5 m in length, are to be supported at mid-length.
- d) Where the ends of stay tubes are of increased thickness, the excess material is to be obtained by forging and not by depositing material by means of welding.
- e) After forging, the ends of stay tubes are to be stress relieved.

3.8.15 Girders

Where tops of combustion chambers, or similar structures, are supported by girders of rectangular section associated with stays, the thickness of the single girder or the aggregate thickness of all girders, at mid-length, is not to be less than

the value t determined by the appropriate formula below, depending upon the number of stays.

- In the case of an odd number of stays:

$$t = \frac{pL(L-s)}{0,25R_m a^2} \cdot \frac{n+1}{n}$$

- In the case of an even number of stays:

$$t = \frac{pL(L-s)}{0,25R_m a^2} \cdot \frac{n+2}{n+1}$$

where:

- p : Design pressure, in MPa
- a : Depth of the girder plate at mid-length, in mm
- L : Length of girder between supports, in mm
- s : Pitch of stays, in mm
- l : Distance between centres of girders, in mm
- n : Number of stays on the girder
- R_m : Minimum ultimate tensile strength of the material used for the plates, in N/mm².

The above formulae refer to the normal arrangement where:

- a) The stays are regularly distributed over the length L .
- b) The distance from the supports of the outer stays does not exceed the uniform pitch s .
- c) When the tops of the combustion chambers are connected to the sides with curved parts with an external radius less than $0,5 l$, the distance of end girders from the inner part of the side surface does not exceed l .
- d) When the curvature radius mentioned under c) above exceeds $0,5 l$, the distance of the end girders from the beginning of the connection does not exceed $0,5 l$.

In other cases a direct calculation is to be made using a safety factor not less than 5, with respect to the minimum value of the tensile strength R_m .

3.8.16 Ogee rings

The thickness of ogee rings connecting the furnaces to the shell in vertical auxiliary boilers (see Fig 15), where the latter support the weight of the water above the furnace, is not to be less than the value t , in mm, given by the following formula:

$$t = [1,02 \cdot 10^{-3} \cdot p D_A \cdot (D_A - d_A)]^{0,5} + 1$$

where:

- p : Design pressure, in MPa
- D_A : Inside diameter of boiler shell, in mm
- d_A : Inside diameter of the lower part of the furnace where it joins the ogee ring, in mm

Figure 15 : Ogee Ring

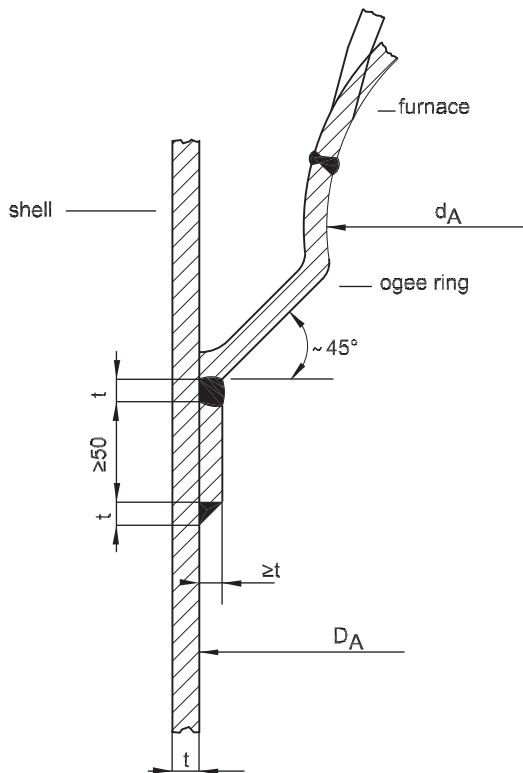

3.8.17 Fire tubes

- a) The thickness of fire tubes subject to external pressure in cylindrical boilers is not to be less than the value t , in mm, calculated by the following formula:

$$t = \frac{pd}{0,15R_m} + 1,8$$

where:

- p : Design pressure, in MPa
 d : Outside diameter of tube, in mm
 R_m : Minimum ultimate tensile strength of the tube material, in N/mm².

The thickness of the tubes is not to be less than 3 mm.

- b) The values of t determined by the above-mentioned formula are to be considered as theoretical values for straight tubes, not taking account of the manufacturing tolerance. Where the tubes are not precise pipes, the thickness calculated by the formula in a) is to be increased by 12,5% to take into account the manufacturing tolerance. In the case of bent tubes, the thickness of the thinner part in way of the bend is not to be less than that given by the above formula.
- c) Whenever abnormal corrosion and erosion may occur during service the corrosion constant of 1,8 in the formula may be increased to the satisfaction of the Society.

3.9 Bottles containing pressurised gases

3.9.1 General

- a) The following requirements apply to bottles intended to contain pressurised and/or liquefied gases at ambient temperature, made by seamless manufacturing processes.
- b) In general, such bottles are to have an outside diameter not exceeding 420 mm, length not exceeding 2000 mm and capacity not exceeding 150 litres (see also [2.6.1]).
- c) For bottles exceeding the above capacity and dimensions, the following requirements may be applied at the discretion of the Society.

3.9.2 Cylindrical shell

The wall thickness of the cylindrical shell is not to be less than the value t , in mm, determined by the following formula:

$$t = \frac{p_H D_E}{2K + p_H}$$

where:

p_H : Hydrostatic test pressure, in MPa. This pressure is to be taken as 1,5 times the setting pressure of the safety valves with the following exceptions:

- 25 MPa for CO₂ bottles
- For refrigerants, the value of hydrostatic test pressure is given in Part F, Chapter 8.

D_E : Outside diameter of tube, in mm

K : $R_{S,MIN} / 1,3$

$R_{S,MIN}$: Value of the minimum yield strength (R_{eH}), or 0,2% proof stress ($R_{p0,2}$), at the ambient temperature, in N/mm². In no case is the value $R_{S,MIN}$ to exceed:

- 0,75 R_m for normalised steels
- 0,90 R_m for quenched and tempered steels

3.9.3 Dished ends

Dished ends are to comply with the following requirements:

- a) Hemispherical ends: the thickness of the ends is to be not less than the thickness calculated for spherical shells in accordance with [3.3.3].
- b) Convex ends: see Fig 16.
- c) Concave base ends: see Fig 17.
- d) Ends with openings: see Fig 18.
- e) Other types of ends will be specially considered by the Society.

3.10 Heat exchangers

3.10.1 Scantlings

- a) Vessels are to be designed in accordance with the applicable requirements stated in [3.3] and [3.4].
- b) Tubes are to be designed in accordance with [3.7.5].
- c) Tube plates are to be designed in accordance with a recognised Standard accepted by the Society.

Figure 16 : Dished convex ends

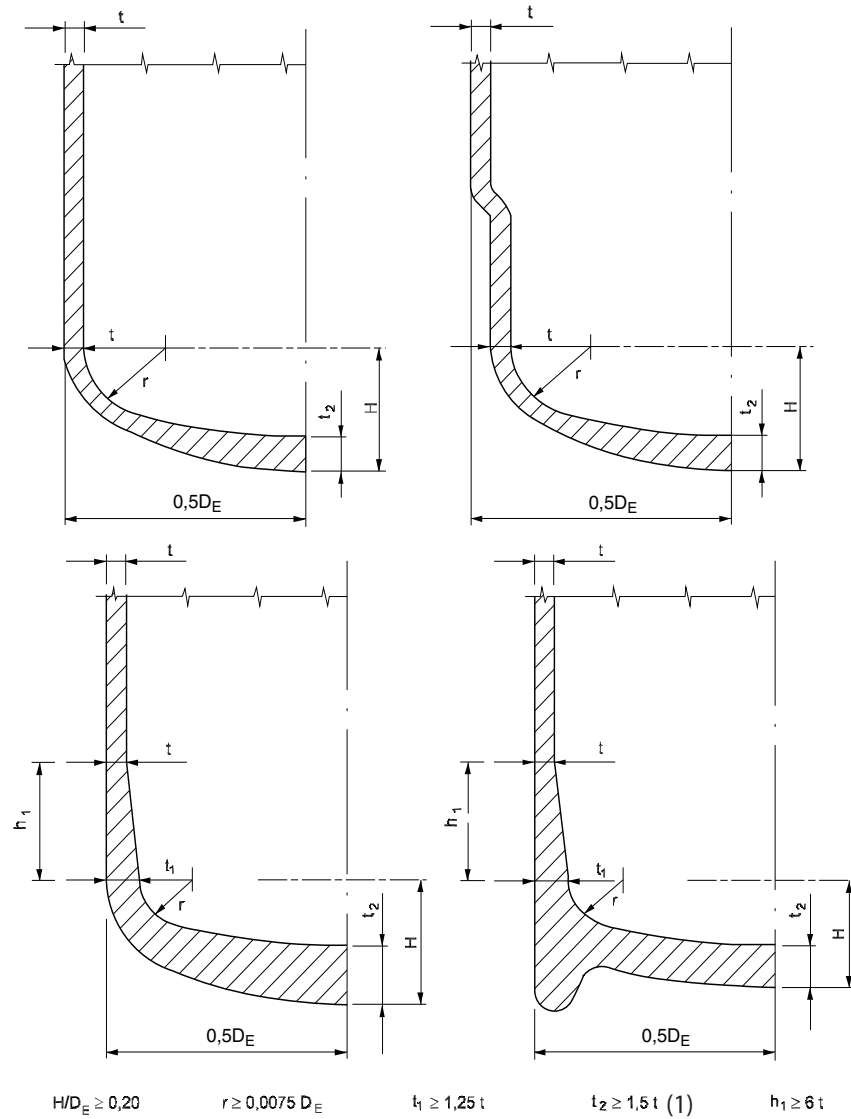

(1) : $t_2 \geq t$ in the case of dished ends manufactured from plates by deep drawing procedure, provided that $H/D_e \geq 0,4$ and thickness according to [3.4.3].

Figure 17 : Dished concave ends

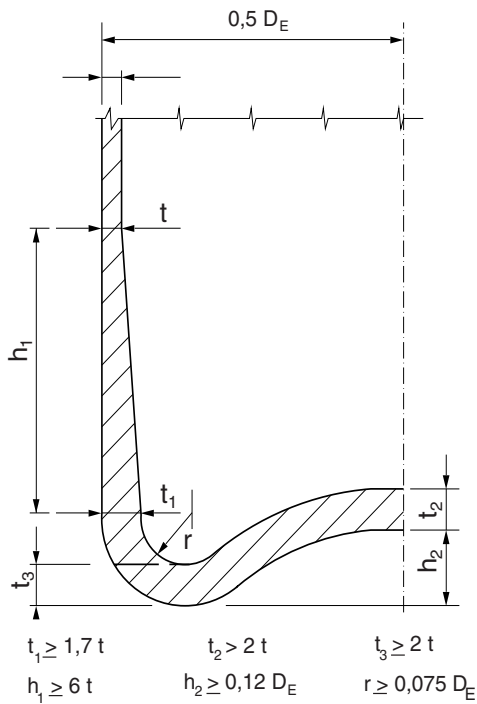
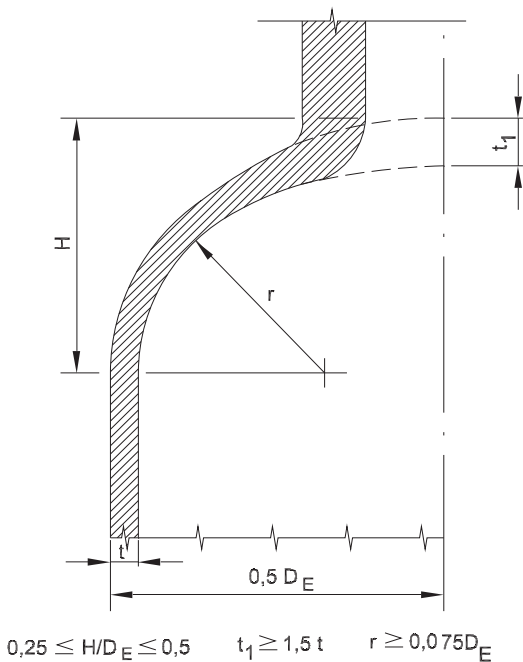

Figure 18 : Heads with openings



3.10.2 Thermal oil heat exchangers

The provisions of [3.10.1] apply also to thermal oil heat exchangers. However, irrespective of the thickness obtained by the formula in [3.7.5], the tube thickness of oil fired and exhaust gas thermal oil heaters is to be not less than the values indicated in Tab 15.

Table 15 : Minimum thickness of thermal oil heat exchanger tubes

Outside diameter in mm	Minimum thickness in mm of tubes subject to internal pressure of oil fired and exhaust gas thermal oil heaters
< 63,5	2,4
70 - 89	2,9
> 89	3,6

4 Design and construction - Fabrication and welding

4.1 General

4.1.1 Base materials

- These requirements apply to boilers and pressure vessels made of steel of weldable quality.
- Fabrication and welding of vessels made of other materials will be the subject of special consideration.

4.1.2 Welding

- Weldings are to be performed in accordance with welding procedures approved by the Society.
- Manual and semi-automatic welding is to be performed by welders qualified by the Society.
- The conditions under which the welding procedures, welding equipment and welders operate are to correspond to those specified in the relevant approvals or qualifications.
- Both ordinary and special electric arc welding processes are covered in the following requirements.

4.1.3 Cutting of plates

- Plates are to be cut by flame cutting, mechanical machining or a combination of both processes. For plates having a thickness less than 25 mm, cold shearing is admitted provided that the sheared edge is removed by machining or grinding for a distance of at least one quarter of the plate thickness with a minimum of 3 mm.
- For flame cutting of alloy steel plates, preheating is to be carried out if necessary.
- The edges of cut plates are to be examined for laminations, cracks or any other defect detrimental to their use.

4.1.4 Forming of the plates

- The forming processes are to be such as not to impair the quality of the material. The Society reserves the right to require the execution of tests to demonstrate the suitability of the processes adopted. Forming by hammering is not allowed.
- Unless otherwise justified, cold formed shells are to undergo an appropriate heat treatment if the ratio of internal diameter after forming to plate thickness is less than 20. This heat treatment may be carried out after welding.
- Before or after welding, hot formed plates are to be normalised or subjected to another treatment suitable for

their steel grade, if hot forming has not been carried out within an adequate temperature range.

d) Plates which have been previously butt-welded may be formed under the following conditions:

- Hot forming:

after forming, the welded joints are to be subjected to radiographic examination or equivalent. In addition, mechanical tests of a sample weld subjected to the same heat treatment are to be carried out.

- Cold forming

cold forming is only allowed for plates having a thickness not exceeding:

- 20 mm for steels having minimum ultimate tensile strength R_m between 360 N/mm² and 410 N/mm²
- 15 mm for steels having R_m between 460 N/mm² and 510 N/mm² as well as for steels 0,3Mo, 1Mn0,5Mo, 1Mn0,5MoV and 0,5Cr0,5Mo;

cold forming is not allowed for steels 1Cr0,5Mo and 2,25Cr1Mo.

- Weld reinforcements are to be carefully ground smooth prior to forming.
- A proper heat treatment is to be carried out after forming, if the ratio of internal diameter to thickness is less than 36, for steels: 460 N/mm², 510 N/mm², 0,3Mo, 1Mn 0,5Mo, 1Mn 0,5MoV and 0,5Cr 0,5Mo.
- After forming, the joints are to be subjected to radiographic examination or equivalent and to a magnetic particle or liquid penetrant test.

4.2 Welding design

4.2.1 Main welded joints

- All joints of class 1 and 2 pressure parts of boilers and pressure vessels are to be butt-welded, with the exception of welding connecting flat heads or tube sheets to shells, for which partial penetration welds or fillet welds may be accepted.
- Joints of class 3 pressure vessels are also subject to the requirement in a), however connection of dished heads to shells by lap welds may be accepted. Fig 19 shows some acceptable details of circumferential lap welds for class 3 pressure vessels.

4.2.2 Shell longitudinal and circumferential welds

Longitudinal and circumferential joints are to be welded from both sides of the plate. Welding from one side may be allowed only when there is evidence that the welding process permits a complete penetration and a sound weld root. If a backing strip is used, it is to be removed after welding and prior to any non-destructive examination. However, the backing strip may be retained in circumferential joints of class 2 vessels, having a thickness not exceeding 15 mm, and of class 3 vessels, provided that the material of the backing strip is such as not to adversely affect the weld.

Figure 19 : Example of acceptable lap-joints

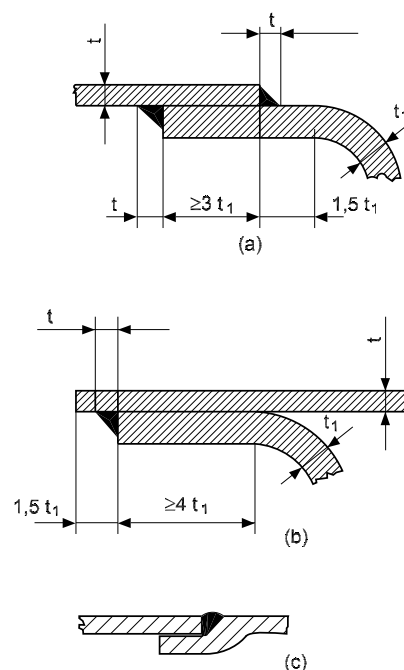

Details (b) and (c) may be used only for pressure vessels having internal diameter less than 600mm.

4.2.3 Plates of unequal thickness

- If plates of unequal thickness are butt-welded and the difference between thicknesses is more than 3 mm, the thicker plate is to be smoothly tapered for a length equal to at least four times the offset, including the width of the weld. For longitudinal joints the tapering is to be made symmetrically on both sides of the plate in order to obtain alignment of middle lines.
- If the joint is to undergo radiographic examination, the thickness of the thicker plate is to be reduced to that of the thinner plate next to the joint and for a length of at least 30 mm.

4.2.4 Dished heads

- For connection of a hemispherical end with a cylindrical shell, the joint is to be arranged in a plane parallel to that of the largest circle perpendicular to the axis of the shell and at such a distance from this plane that the tapering of the shell made as indicated in [4.2.3] is wholly in the hemisphere.
- For torispherical ends made of parts assembled by welding, no welded joint is normally admitted along a parallel in the knuckle nor at a distance less than 50 mm from the beginning of the knuckle.

4.2.5 Welding location

The location of main welded joints is to be chosen so that these joints are not submitted to appreciable bending stresses.

4.2.6 Accessories and nozzles

- Attachment of accessories by welds crossing main welds or located near such welds is to be avoided;

where this is impracticable, welds for attachment of accessories are to completely cross the main welds rather than stop abruptly on or near them.

- b) Openings crossing main joints or located near main joints are also to be avoided as far as possible.
- c) Doubling plates for attachment of accessories such as fixing lugs or supports are to be of sufficient size to ensure an adequate distribution of loads on pressure parts; such doubling plates are to have well rounded corners. Attachment of accessories such as ladders and platforms directly on the walls of vessels such that they restrain their free contraction or expansion is to be avoided.
- d) Welded connections of nozzles and other fittings, either with or without local compensation, are to be of a suitable type, size and preparation in accordance with the approved plans.

4.2.7 Connections of stays to tube plates

- a) Where stays are welded, the cross-sectional area of the weld is to be at least 1,25 times the cross-section of the stay.
- b) The cross-sectional area of the end welding of welded stay tubes is to be not less than 1,25 times the cross-sectional area of the stay tube.

4.2.8 Type of weldings

Fig 20, Fig 21, Fig 22, Fig 23, Fig 24, Fig 25, Fig 26, Fig 27, Fig 28 and Fig 29 indicate the type and size of weldings of typical pressure vessel connections. Any alternative type of welding or size will be the subject of special consideration by the Society.

4.3 Miscellaneous requirements for fabrication and welding

4.3.1 Welding position

- a) As far as possible, welding is to be carried out in the downhand horizontal position and arrangements are to be foreseen so that this can be applied in the case of circumferential joints.
- b) When welding cannot be performed in this position, tests for qualification of the welding process and the welders are to take account thereof.

4.3.2 Cleaning of parts to be welded

- a) Parts to be welded are, for a distance of at least 25mm from the welding edges, to be carefully cleaned in order

to remove any foreign matter such as rust, scale, oil, grease and paint.

- b) If the weld metal is to be deposited on a previously welded surface, all slag or oxide is to be removed to prevent inclusions.

4.3.3 Protection against adverse weather conditions

- a) Welding of pressure vessels is to be done in a sheltered position free from draughts and protected from cold and rain.
- b) Unless special justification is provided, no welding is to be performed if the temperature of the base metal is less than 0°C.

4.3.4 Interruption in welding

If, for any reason, welding is stopped, care is to be taken on restarting to obtain a complete fusion.

4.3.5 Backing weld

When a backing weld is foreseen, it is to be carried out after suitable chiseling or chipping at the root of the first weld, unless the welding process applied does not call for such an operation.

4.3.6 Appearance of welded joints

- a) Welded joints are to have a smooth surface without under-thickness; their connection with the plate surface is to be gradual without undercutting or similar defects.
- b) The weld reinforcement of butt welds, on each side of the plate, is not to exceed the following thickness:
 - 2,5mm for plates having a thickness not exceeding 12mm
 - 3mm for plates having a thickness greater than 12mm but less than 25mm
 - 5mm for plates having a thickness at least equal to 25mm.

4.4 Preparation of parts to be welded

4.4.1 Preparation of edges for welding

- a) Grooves and other preparations of edges for welding are to be made by machining, chipping or grinding. Flame cutting may also be used provided that the zones damaged by this operation are removed by machining, chipping or grinding. For alloy steel plates, preheating is to be provided, if needed, for flame cutting.
- b) Edges prepared are to be carefully examined to check that there are no defects detrimental to welding.

Figure 20 : Types of joints for unstayed flat heads (1)

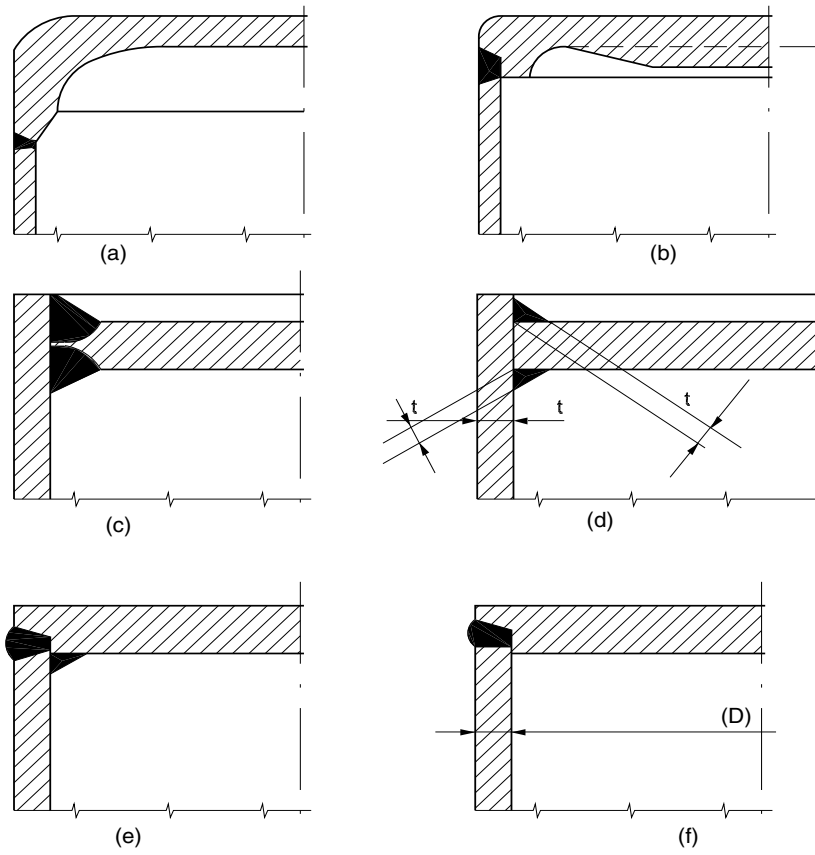

Figure 21 : Types of joint for unstayed flat heads (2)

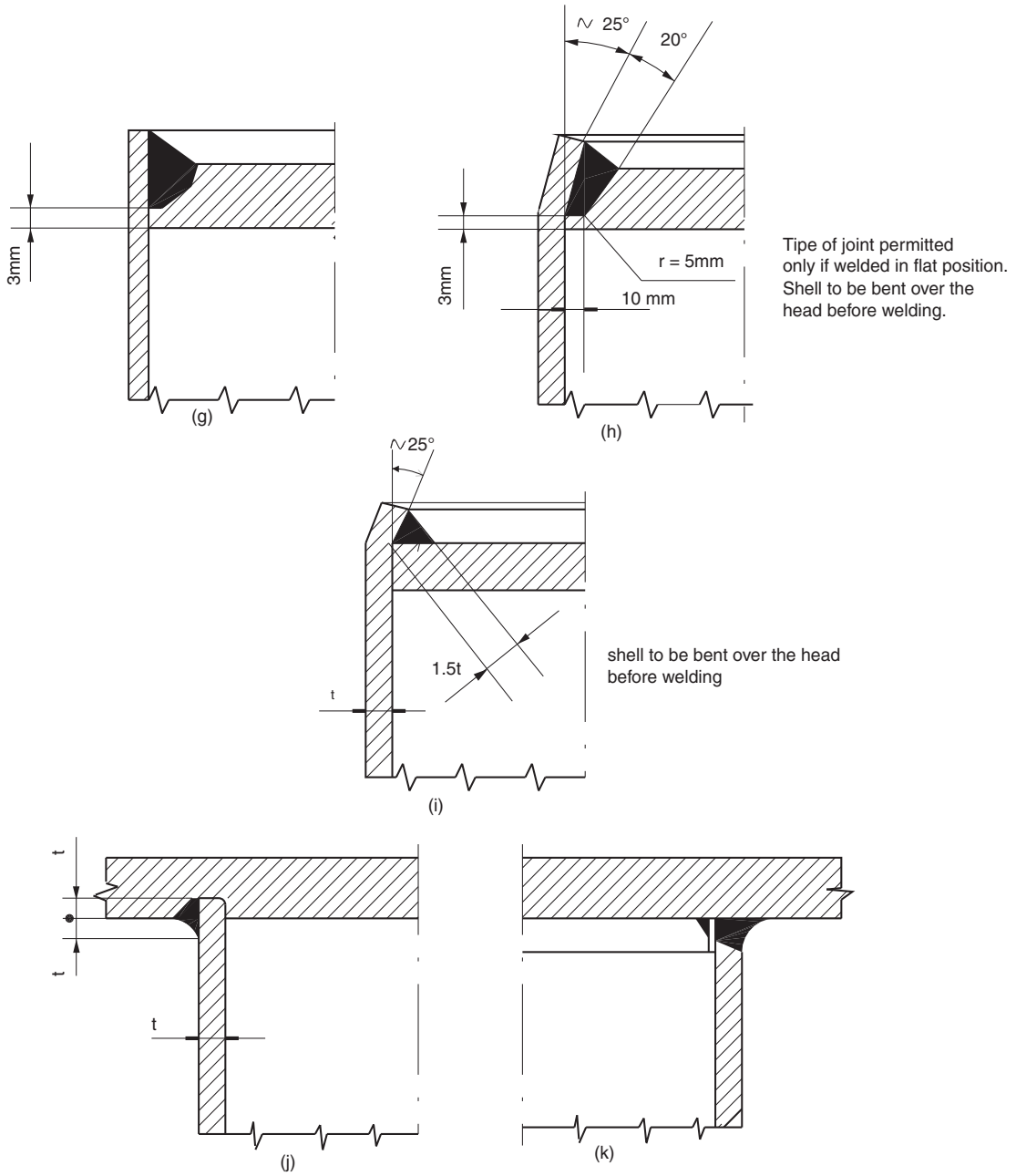

Figure 22 : Types of joints for nozzles and reinforcing rings (1)

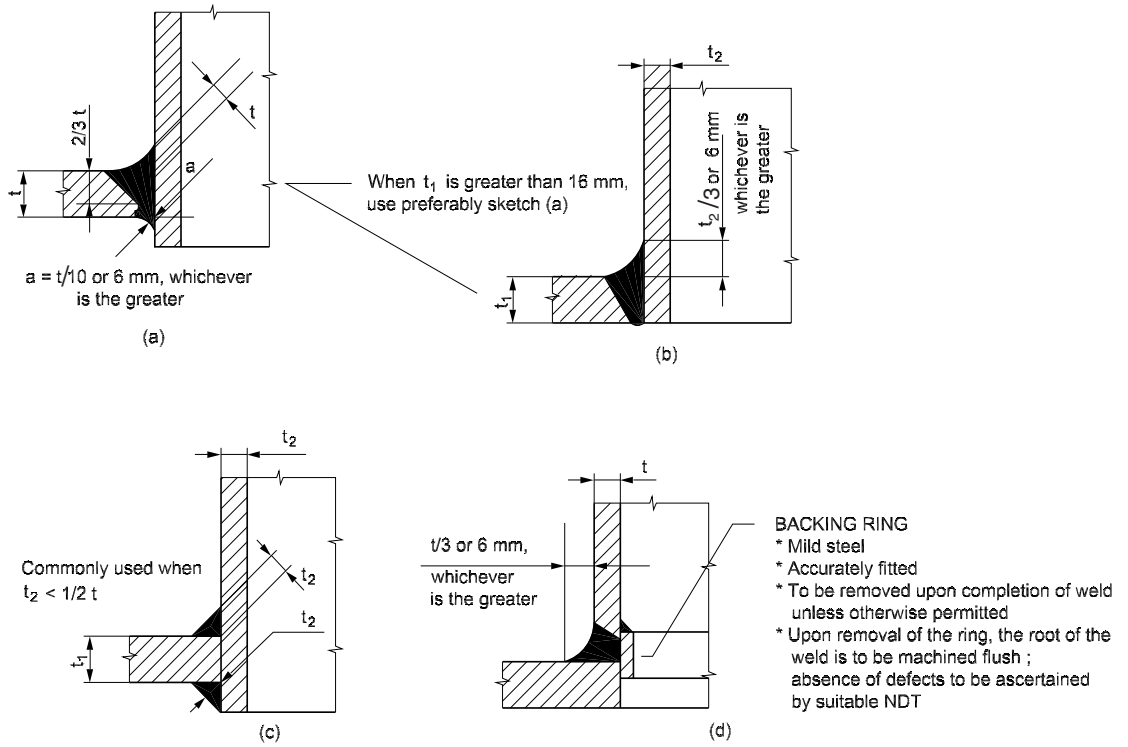

Figure 23 : Types of joint for nozzles and reinforcing rings (2)

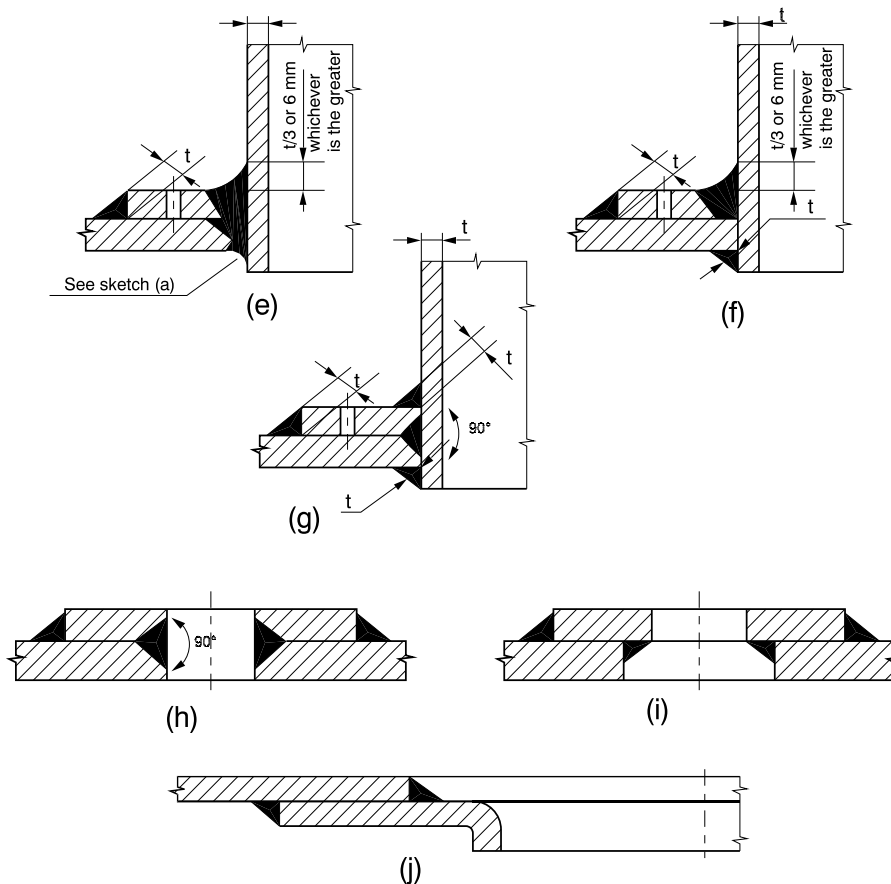

Figure 24 : Types of joint for nozzles and reinforcing rings (3)

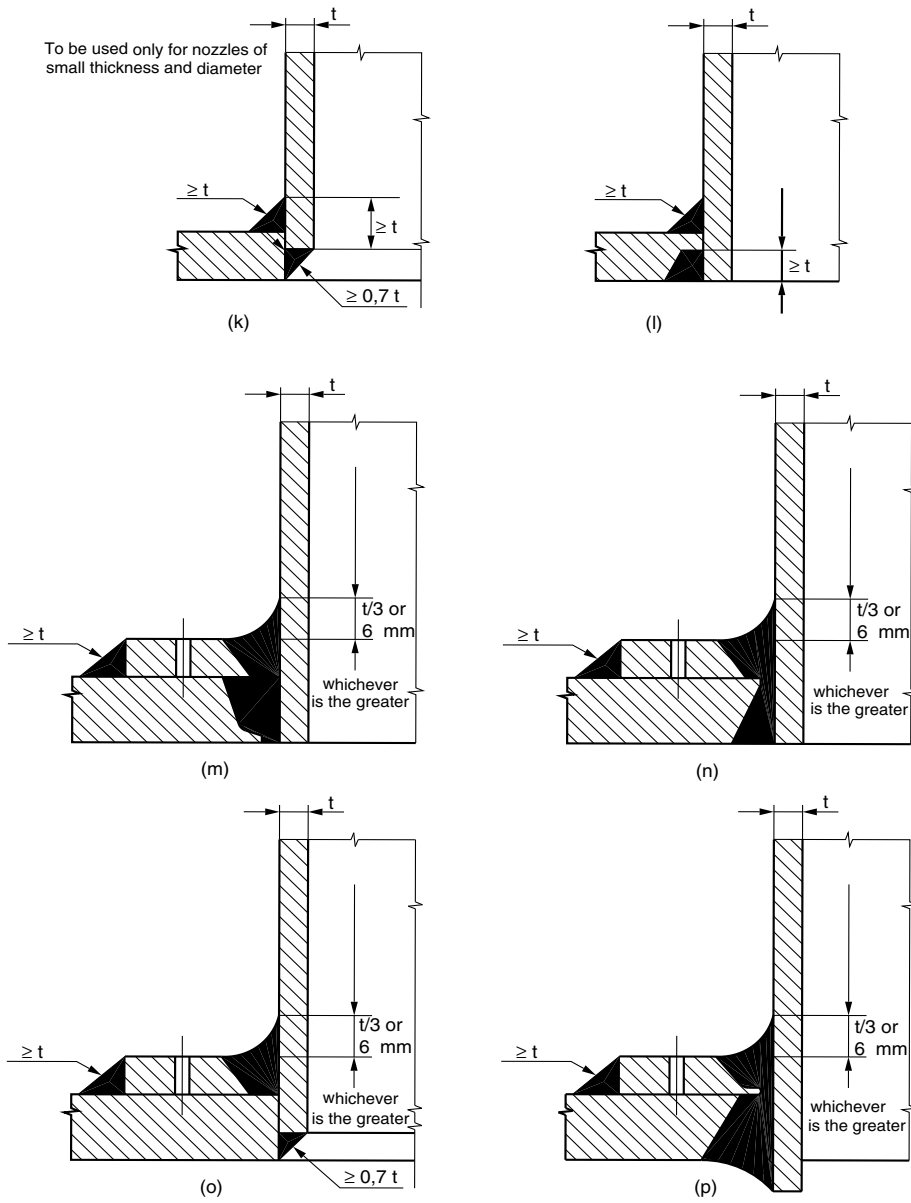
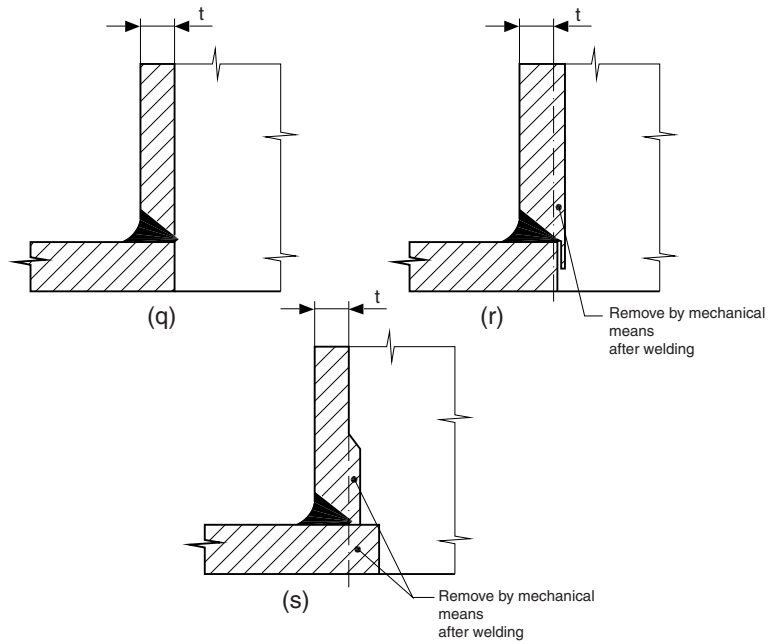

Figure 25 : Types of joints for nozzles (4)



Note: Where preparations of Fig 25 are carried out, the shell is to be carefully inspected to ascertain the absence of lamination.

Figure 26 : Types of joint for flanges to nozzles

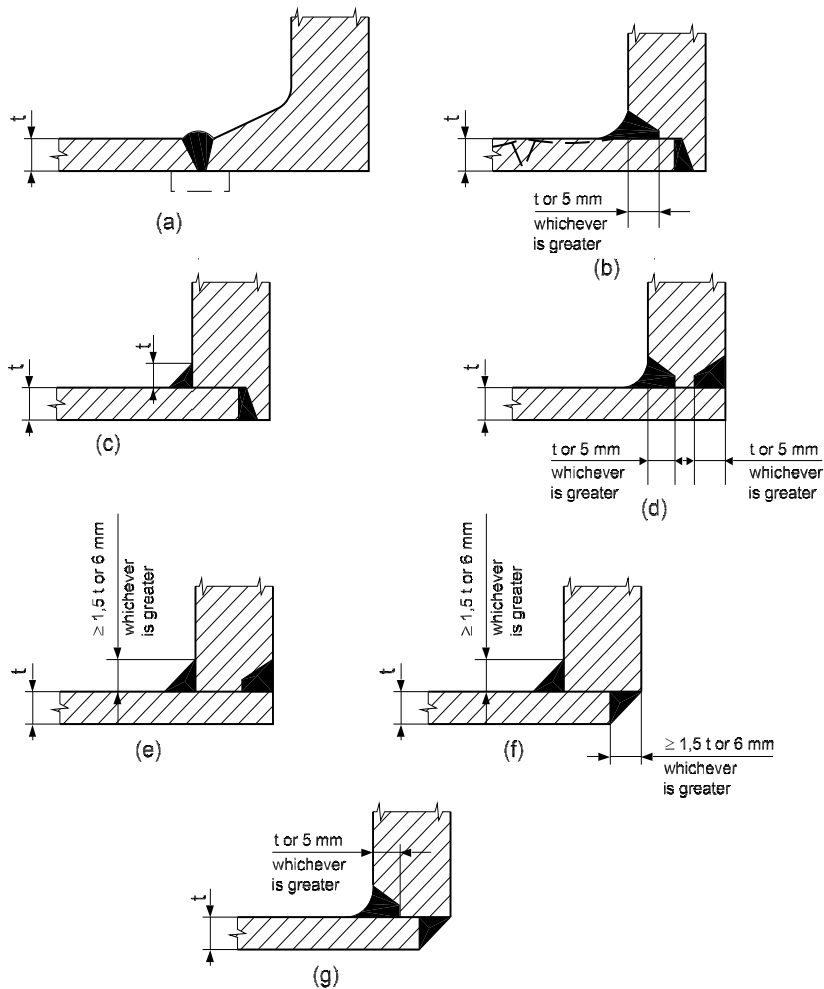

Figure 27 : Types of joint for tubesheets to shells (direct connection)

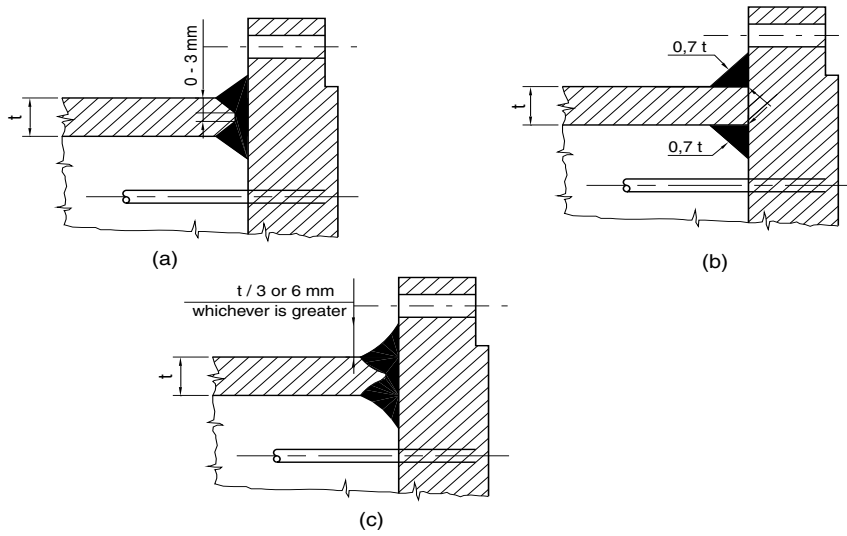

Figure 28 : Types of joints for tubesheets to shells (butt welded)

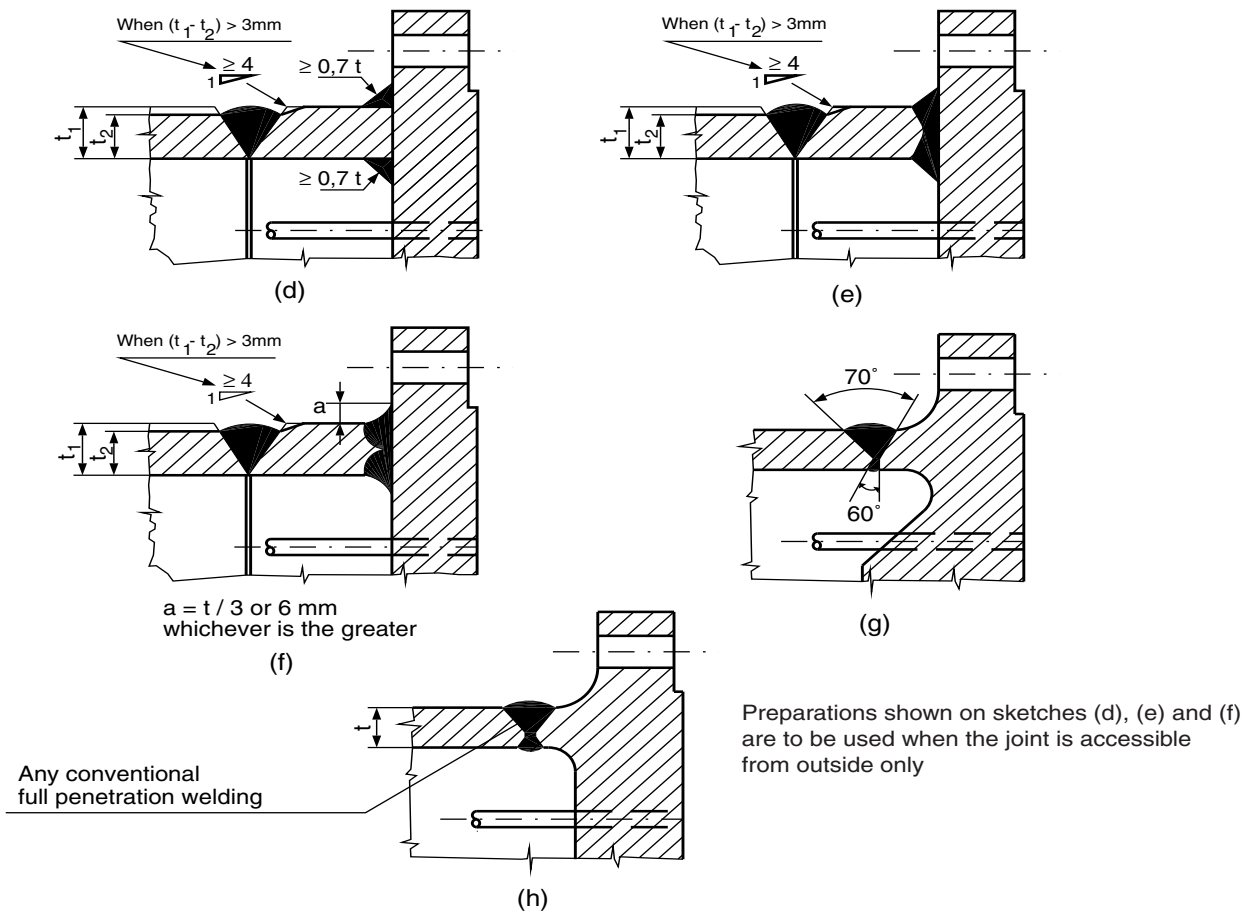
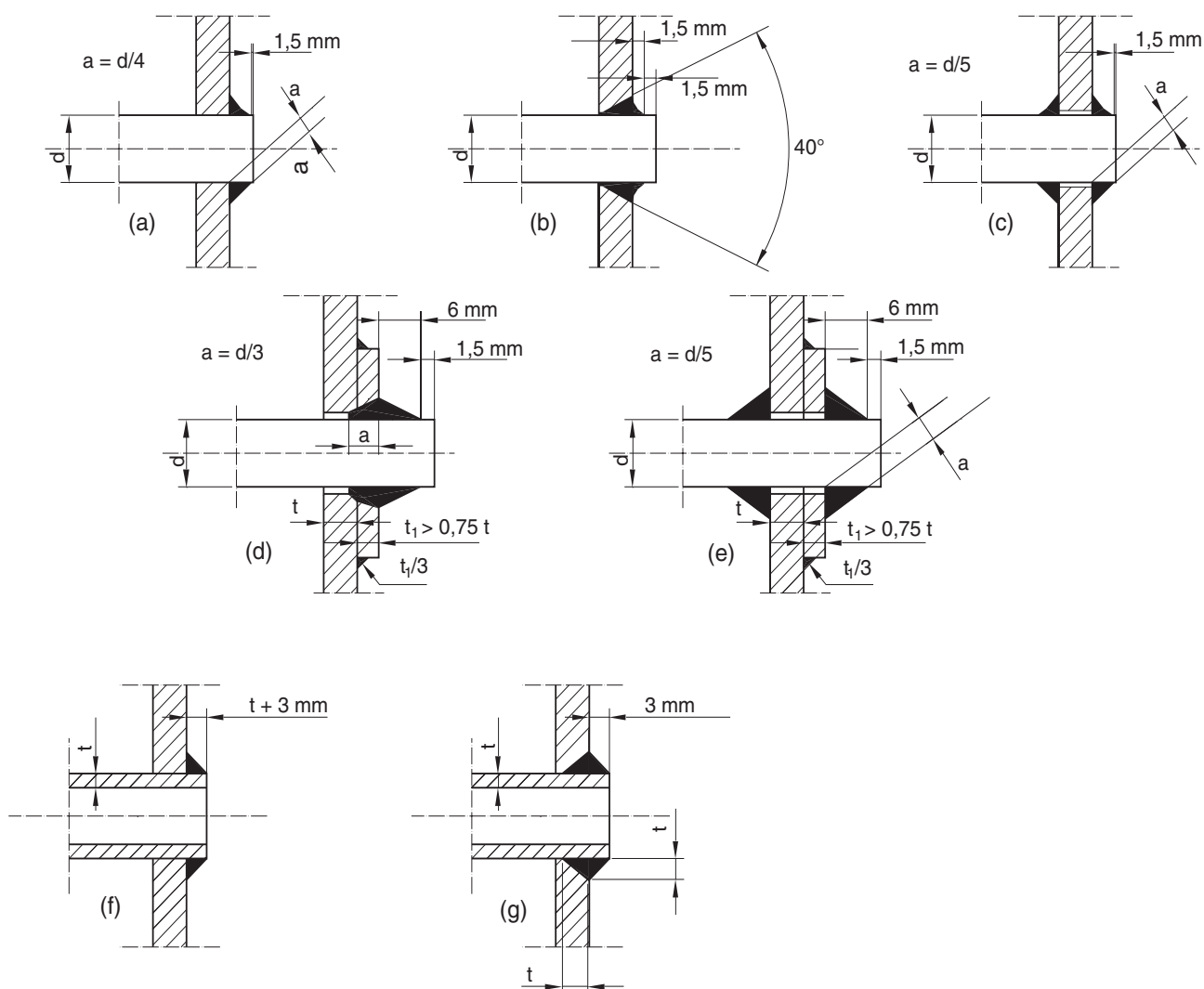

Figure 29 : Type of joints for stays and stay tubes



4.4.2 Abutting of parts to be welded

- Abutting of parts to be welded is to be such that surface misalignment of plates does not exceed:
 - 10% of the thickness of the plate with a maximum of 3 mm for longitudinal joints
 - 10% of the thickness of the plate plus 1 mm with a maximum of 4 mm for circumferential joints.
- For longitudinal joints, middle lines are to be in alignment within 10% of the thickness of the thinner plate with a maximum of 3 mm.
- Plates to be welded are to be suitably retained in position in order to limit deformation during welding. The arrangements are to be such as to avoid modification of the relative position of parts to be welded and misalignment, after welding, exceeding the limits indicated above.
- Temporary welds for abutting are to be carried out so that there is no risk of damage to vessel shells. Such welds are to be carefully removed after welding of the

vessel and before any heat treatment. Non-destructive testing of the corresponding zones of the shell may be required by the Surveyor if considered necessary.

- Accessories such as doubling plates, brackets and stiffeners are to be suitable for the surface to which they are to be attached.

4.5 Tolerances after construction

4.5.1 General

The sizes and shape of vessels are to be checked after welding for compliance with the design taking into account the tolerances given below. The Society reserves the right to stipulate smaller values for these tolerances for vessels subjected to special loads.

Any defect in shape is to be gradual and there is to be no flat area in way of welded joints.

Measurements are to be taken on the surface of the parent plate and not on the weld or other raised part.

4.5.2 Straightness

The straightness of cylindrical shells is to be such that their deviation from the straight line does not exceed 0,6% of their length, with a maximum of 15 mm for each 5 m of length.

4.5.3 Out-of-roundness

- a) Out-of-roundness of cylindrical shells is to be measured either when set up on end or when laid flat on their sides; in the second case, measures of diameters are to be repeated after turning the shell through 90° about its axis and out-of-roundness is to be calculated from the average of the two measures of each diameter.
- b) For any transverse section, the difference between the maximum and minimum diameters is not to exceed 1% of the nominal diameter D with a maximum of:

$$(D + 1250) / 200, \quad D \text{ being expressed in mm.}$$

For large pressure vessels, this limit may be increased by a maximum of 0,2% of the internal diameter of the vessel. Any possible out-of-roundness within the above limit is to be gradual and there are to be no localised deformations in way of the welded joints.

4.5.4 Irregularities

Irregularities in profile of cylindrical shells, checked by a 20° gauge, are not to exceed 5% of the thickness of the plate plus 3 mm. This value may be increased by 25% if the length of the irregularity does not exceed one quarter of the distance between two circumferential seams, with a maximum of 1 mm.

4.6 Preheating

4.6.1

- a) Preheating, to be effectively maintained during the welding operation, may be required by the Society when deemed necessary in relation to a number of circumstances, such as the type of steel, thickness of the base material, welding procedure and technique, type of restraint, and heat treatment after welding, if any.
- b) The preheating temperature will be determined accordingly. However, a preheating temperature of approximately 150°C is required for 0,5Mo or 1Cr0,5Mo type steel, and approximately 250°C for 2,25Cr1Mo type steel.
- c) These requirements also apply to welding of nozzles, fittings, steam pipes and other pipes subject to severe conditions.

4.7 Post-weld heat treatment

4.7.1 General

- a) When post-weld heat treatment of a vessel is to be carried out, such treatment is to consist of:
- heating the vessel slowly and uniformly up to a temperature suitable for the grade of steel
 - maintaining this temperature for a duration determined in relation to the actual thickness t_A of the vessel and the grade of steel
 - slowly cooling the vessel in the furnace down to a temperature not exceeding 400°C, with subsequent cooling allowed out of the furnace in still air.
- b) As far as possible, vessels are to be heat treated in a single operation. However, when the sizes of the vessels are such that heat treatment requires several operations, care is to be taken such that all the parts of the vessels undergo heat treatment in a satisfactory manner. In particular, a cylindrical vessel of great length may be treated in sections in a furnace if the overlap of the heated sections is at least 1500 mm and if parts outside the furnace are lagged to limit the temperature gradient to an acceptable value.

4.7.2 Thermal stress relieving

Upon completion of all welding, including connections of nozzles, doublers and fittings, pressure vessels of classes 1 and 2, boilers and associated parts are to be subjected to an effective stress relieving heat treatment in the following cases:

- Pressure vessels of classes 1 and 2 containing fluids at a temperature not less than the ambient temperature, where the thickness exceeds that indicated in Tab 16
- Boilers and steam generators for thicknesses higher than 20 mm or, depending upon the type of steel, for lower thicknesses as required for class 1 pressure vessels.

Applications at temperatures less than the ambient temperature and/or steels other than those indicated above will be the subject of special consideration by the Society.

Stress relieving heat treatment will not be required when the minimum temperature of the fluid is at least 30°C higher than the KV-notch impact test temperature specified for the steel; this difference in temperature is also to be complied with for welded joints (both in heat-affected zones and in weld metal).

Pressure vessels and pipes of class 3 and associated parts are not required to be stress relieved, except in specific cases.

4.7.3 Heat treatment procedure

The temperature of the furnace at the time of introduction of the vessel is not to exceed 400°C.

- a) The heating rate above 400°C is not to exceed:
- 1) 220°C per hour if the maximum thickness is not more than 25 mm, or
 - 2) $(5500/t_A)^\circ\text{C}$ per hour, with a minimum of 55°C per hour, if the maximum thickness t_A , in mm, is more than 25 mm

b) The absolute value of the cooling rate in the furnace is not to exceed:

- 1) 280°C per hour if the maximum thickness is not more than 25 mm, or
- 2) $(7000/t_A)^\circ\text{C}$ per hour, with a minimum of 55°C per hour, if the maximum thickness t_A , in mm, is more than 25 mm.

Unless specially justified, heat treatment temperatures and duration for maintaining these temperatures are to comply with the values in Tab 17.

Table 16 : Thermal stress relieving

Grade	Thickness (mm) above which post-weld heat treatment is required	
	Boilers	Unfired pressure vessels
$R_m = 360 \text{ N/mm}^2$ Grade HA $R_m = 410 \text{ N/mm}^2$ Grade HA	14,5	14,5
$R_m = 360 \text{ N/mm}^2$ Grade HB $R_m = 410 \text{ N/mm}^2$ Grade HB	20	30
$R_m = 360 \text{ N/mm}^2$ Grade HD $R_m = 410 \text{ N/mm}^2$ Grade HD	20	38
$R_m = 460 \text{ N/mm}^2$ Grade HB $R_m = 510 \text{ N/mm}^2$ Grade HB	20	25
$R_m = 460 \text{ N/mm}^2$ Grade HD $R_m = 510 \text{ N/mm}^2$ Grade HD	20	35
0,3Mo 1Mn 0,5Mo 1Mn 0,5MoV 0,5Cr 0,5Mo	20	20
1Cr 0,5Mo 2,25Cr1Mo	all	all

Table 17 : Heat treatment procedure

Grade	Temperatures	Time per 25 mm of maximum thickness	Minimum time
Carbon steels	580-620°C	1 hour	1 hour
0,3Mo 1Mn 0,5Mo 1Mn 0,5MoV 0,5Cr 0,5Mo	620-660°C	1 hour	1 hour
1Cr 0,5Mo	620-660°C	1hour	2 hours
2,25Cr 1Mo	600-750°C (1)	2 hours	2 hours
(1) The temperature is to be chosen, with a tolerance of $\pm 20^\circ\text{C}$, in this temperature range in order to obtain the required mechanical characteristics			

4.7.4 Alternatives

When, for special reasons, heat treatment is carried out in conditions other than those given in [4.7.2], all details regarding the proposed treatment are to be submitted to the Society, which reserves the right to require tests or further investigations in order to verify the efficiency of such treatment.

4.7.5 Execution of heat treatment

Furnaces for heat treatments are to be fitted with adequate means for controlling and recording temperature; temperatures are to be measured on the vessel itself. The atmosphere in the furnaces is to be controlled in order to avoid abnormal oxidation of the vessel.

4.7.6 Treatment of test plates

Test plates are normally to be heated at the same time and in the same furnace as the vessel.

When separate heat treatment of test plates cannot be avoided, all precautions are to be taken such that this treatment is carried out in the same way as for the vessel, specifically with regard to the heating rate, the maximum temperature, the duration for maintaining this temperature and the cooling conditions.

4.7.7 Welding after heat treatment

- a) Normally, welding after heat treatment is only allowed if:
 - the throat of welding fillets does not exceed 10 mm
 - the largest dimension of openings in the vessel for the accessories concerned does not exceed 50 mm.
- b) Any welding of branches, doubling plates and other accessories on boilers and pressure vessels after heat treatment is to be submitted for special examination by the Society.

4.8 Welding samples

4.8.1 Test plates for welded joints

- a) Test plates of sufficient size, made of the same grade of steel as the shell plates, are to be fitted at each end of the longitudinal joints of each vessel so that the weld in the test plates is the continuation of these welded joints. There is to be no gap when passing from the deposited metal of the joint to the deposited metal of the test plate.
- b) No test plate is required for circumferential joints if these joints are made with the same process as longitudinal joints. Where this is not the case, or if there are only circumferential joints, at least one test plate is to be welded separately using the same welding process as for the circumferential joints, at the same time and with the same welding materials.
- c) Test plates are to be stiffened in order to reduce as far as possible warping during welding. The plates are to be straightened prior to their heat treatment which is to be carried out in the same conditions as for the corresponding vessel (see also [4.7.6]).

- d) After radiographic examination, the following test pieces are to be taken from the test plates:
- one test piece for tensile test on welded joint
 - two test pieces for bend test, one direct and one reverse
 - three test pieces for impact test
 - one test piece for macrographic examination.

4.8.2 Mechanical tests of test plates

- a) The tensile strength on welded joint is not to be less than the minimum specified tensile strength of the plate.
- b) The bend test pieces are to be bent through an angle of 180° over a former of 4 times the thickness of the test piece. There is to be no crack or defect on the outer surface of the test piece exceeding in length 1,5 mm transversely or 3 mm longitudinally. Premature failure at the edges of the test piece is not to lead to rejection. As an alternative, the test pieces may be bent through an angle of 120° over a former of 3 times the thickness of the test piece.
- c) The impact energy measured at 0°C is not to be less than the values given in Part D for the steel grade concerned.
- d) The test piece for macrographic examination is to permit the examination of a complete transverse section of the weld. This examination is to demonstrate good penetration without lack of fusion, large inclusions and similar defects. In case of doubt, a micrographic examination of the doubtful zone may be required.

4.8.3 Re-tests

- a) If one of the test pieces yields unsatisfactory results, two similar test pieces are to be taken from another test plate.
- b) If the results for these new test pieces are satisfactory and if it is proved that the previous results were due to local or accidental defects, the results of the re-tests may be accepted.

4.9 Specific requirements for class 1 vessels

4.9.1 General

The following requirements apply to class 1 pressure vessels, as well as to pressure vessels of other classes, whose scantlings have been determined using an efficiency of welded joint e greater than 0,90.

4.9.2 Non-destructive tests

- a) All longitudinal and circumferential joints of class 1 vessels are to be subject of 100% radiographic or equivalent examination with the following exceptions:
- for pressure vessels or parts designed to withstand external pressures only, at the Society's discretion, the extent may be reduced up to approximately 30% of the length of the joints. In general, the positions included in the examinations are to include all welding crossings;
 - for vessels not intended to contain toxic or dangerous matters, made of carbon steels having thickness

below 20 mm when the joints are welded by approved automatic processes at the Society's discretion, the extent may be reduced up to approximately 10% of the length of the joints. In general, the positions included in the examinations are to include all welding crossings;

- for circumferential joints having an external diameter not exceeding 175 mm, at the Society's discretion, the extent may be reduced up to approximately 10% of the total length of the joints.
- b) Fillet welds for parts such as doubling plates, branches or stiffeners are to undergo a spot magnetic particle test for at least 10% of their length. If magnetic particle tests cannot be used, it is to be replaced by liquid penetrant test.
- c) Welds for which non destructive tests reveal unacceptable defects, such as cracks or areas of incomplete fusion, are to be rewelded and are then to undergo a new non destructive examination

4.9.3 Number of test samples

- a) During production, at least one test plate for each 20 m of length (or fraction) of longitudinal weldings is to be tested as per [4.8.2].
- b) During production, at least one test plate for each 30 m of length (or fraction) of circumferential welding is to be tested as per [4.8.2].
- c) When several vessels made of plates of the same grade of steel, with thicknesses varying by not more than 5 mm, are welded successively, only one test plate may be accepted per each 20 m of length of longitudinal joints (or fraction) and per each 30 m of circumferential welding (or fraction) provided that the welders and the welding process are the same. The thickness of the test plates is to be the greatest thickness used for these vessels.

4.10 Specific requirements for class 2 vessels

4.10.1 General

For vessels whose scantlings have been determined using an efficiency of welded joint e greater than 0,90, see [4.9.1].

4.10.2 Non-destructive tests

All longitudinal and circumferential joints of class 2 vessels are to be subjected to 10% radiographic or equivalent examination. This extension may be extended at the Society's discretion based on the actual thickness of the welded plates.

As specified in Tab 10, where a joint efficiency of 0,75 is used in the formula for the calculation of the thickness of the vessel, the radiographic and the ultrasonic examinations may be omitted.

This assumes, however, that the Surveyor of the Society will adequately follow all the welding phases and that checks are completed by any non-destructive examinations deemed necessary.

4.10.3 Number of test samples

In general, the same requirements of [4.9.3] apply also to class 2 pressure vessels. However, test plates are required for each 50 m of longitudinal and circumferential weldings (or fraction).

4.11 Specific requirements for Class 3 vessels

4.11.1 For vessels whose scantlings have been determined using an efficiency of welded joint e greater than 0,90, see [4.9.1].

Heat treatment, mechanical tests and non-destructive tests are not required for welded joints of other Class 3 vessels.

5 Design and construction - Control and monitoring

5.1 Boiler control and monitoring system

5.1.1 Local control and monitoring

Means to effectively operate, control and monitor the operation of oil fired boilers and their associated auxiliaries are to be provided locally. The functional condition of the fuel, feed water and steam systems and the boiler operational status are to be indicated by pressure gauges, temperature indicators, flow-meter, lights or other similar devices.

5.1.2 Emergency shut-off

Means are to be provided to shut down boiler forced draft or induced draft fans and fuel oil service pumps from outside the space where they are located, in the event that a fire in that space makes their local shut-off impossible.

5.1.3 Water level indicators

- Each boiler is to be fitted with at least two separate means for indicating the water level. One of these means is to be a level indicator with transparent element. The other may be either an additional level indicator with transparent element or an equivalent device. Level indicators are to be of an approved type.
- The transparent element of level indicators is to be made of glass, mica or other appropriate material.
- Level indicators are to be located so that the water level is readily visible at all times. The lower part of the transparent element is not to be below the safety water level defined by the builder.
- Level indicators are to be fitted either with normally closed isolating cocks, operable from a position free from any danger in case of rupture of the transparent element or with self-closing valves restricting the steam release in case of rupture of this element.

5.1.4 Water level indicators - Special requirements for water tube boilers

For water tube boilers having an athwartships steam drum more than 4 m in length, a level indicator is to be fitted at each end of the drum.

5.1.5 Water level indicators - Special requirements for fire tube boilers (vertical and cylindrical boilers)

- For cylindrical boilers, the two water level indicators mentioned in [5.1.3] are to be distributed at each end of the boiler; i.e. double front cylindrical boilers are to have two level indicators on each front.
- A system of at least two suitably located and remote controlled gauge-cocks may be considered as the equivalent device mentioned in [5.1.3] for cylindrical boilers having a design pressure lower than 1 MPa, for cylindrical boilers having a diameter lower than 2 m and for vertical boilers having height lower than 2,3 m. Gauge-cocks are to be fixed directly on the boiler shell.
- Where level indicators are not fixed directly on the boiler shell, but on level pillars, the internal diameter of such pillars is not to be less than the value d_N given in Tab 18. Level pillars are to be either fixed directly on the boiler shell or connected to the boiler by pipes fitted with cocks secured directly to the boiler shell. The internal diameter of these pipes d_C is not to be less than the values given in Tab 18. The upper part of these pipes is to be arranged so that there is no bend where condense water can accumulate. These pipes are not to pass through smoke boxes or uptakes unless they are located inside metallic ducts having internal diameter exceeding by not less than 100 mm the external diameter of the pipes. Fig 30 shows the sketch of a level pillar arrangement.

Table 18 : Minimum internal diameters d_N and d_C

Internal diameter of the boiler	d_N (mm)	d_C (mm)
$D > 3$ m	60	38
$2,30 \text{ m} \leq D \leq 3$ m	50	32
$D < 2,30$ m	45	26

Figure 30 : Level pillar arrangement

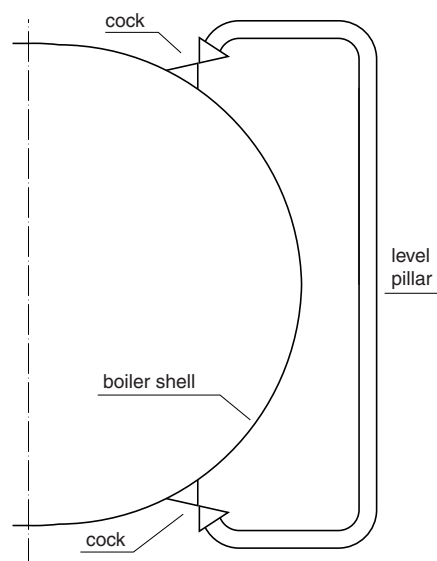

5.1.6 Pressure control devices

- a) Each boiler is to be fitted with a steam pressure gauge so arranged that its indications are easily visible from the stokehold floor. A steam pressure gauge is also to be provided for superheaters which can be shut off from the boiler they serve.
- b) Pressure gauges are to be graduated in units of effective pressure and are to include a prominent legible mark for the pressure that is not to be exceeded in normal service.
- c) Each pressure gauge is to be fitted with an isolating cock.
- d) Double front boilers are to have a steam pressure gauge arranged in each front.

5.1.7 Temperature control devices

Each boiler fitted with a superheater is to have an indicator or recorder for the steam temperature at the superheater outlet.

5.1.8 Automatic shut-off of oil fired propulsion and auxiliary boilers

- a) Each burner is to be fitted with a flame scanner designed to automatically shut off the fuel supply to the burner in the event of flame failure. In the case of failure of the flame scanner, the fuel to the burner is to be shut off automatically.
- b) A low water condition is to automatically shut off the fuel supply to the burners. The shut-off is to operate before the water level reaches a level so low as to affect the safety of the boiler and no longer be visible in the gauge glass. Means are to be provided to minimise the risk of shut-off provoked by the effect of roll and pitch and/or transients. This shut-off system need not be installed in auxiliary boilers which are under local supervision and are not intended for automatic operation.
- c) Forced draft failure is to automatically shut off the fuel supply to the burners.
- d) Loss of boiler control power is to automatically shut off the fuel supply to the burners.

5.1.9 Alarms

Any actuation of the fuel-oil shut-off listed in [5.1.8] is to operate a visual and audible alarm.

5.1.10 Additional requirements for boilers fitted with automatic control systems

- a) The flame scanner required in [5.1.8] a) is to operate within 6 seconds from the flame failure.
- b) A timed boiler purge with all air registers open is to be initiated manually or automatically when boilers are fitted with an automatic ignition system. The purge time is based on a minimum of 4 air changes of the combustion chamber and furnace passes. Forced draft fans are to be operating and air registers and dampers are to be open before the purge time commences.
- c) Means are to be provided to bypass the flame scanner control system temporarily during a trial-for-ignition for a period of 15 seconds from the time the fuel reaches the burners. Except for this trial-for-ignition period, no

means are to be provided to bypass one or more of the burner flame scanner systems unless the boiler is locally controlled.

- d) Where boilers are fitted with an automatic ignition system, and where residual fuel oil is used, means are to be provided for lighting of burners with igniters lighting properly heated residual fuel oil. In the case of flame failure, the burner is to be brought back into automatic service only in the low-firing position.
- e) An alarm is to be activated whenever a burner operates outside the limit conditions stated by the manufacturer.
- f) Immediately after normal shutdown, an automatic purge of the boiler equal to the volume and duration of the pre-purge is to occur. Following automatic fuel valve shut-off, the air flow to the boiler is not to automatically increase; post-purge in such cases is to be carried out under manual control.
- g) Propulsion and auxiliary boilers associated with propulsion machinery intended for centralised, unattended operations are to comply with the requirements of Chapter 3.

5.2 Pressure vessel instrumentation

5.2.1

- a) Pressure vessels are to be fitted with the necessary devices for checking pressure, temperature and level, where it is deemed necessary.
- b) In particular, each air pressure vessel is to be fitted with a local manometer.

5.3 Thermal oil heater control and monitoring

5.3.1 Local control and monitoring

Suitable means to effectively operate, control and monitor the operation of oil fired thermal oil heaters and their associated auxiliaries are to be provided locally. The functional condition of the fuel, thermal oil circulation, forced draft and flue gas systems is to be indicated by pressure gauges, temperature indicators, flow-meter, lights or other similar devices.

5.3.2 Flow control and monitoring

- a) A flow indicator of the thermal oil is to be provided.
- b) Oil fired or exhaust gas heaters are to be provided with a flow monitor limit-switch. If the flow rate falls below a minimum value the firing system is to be switched off and interlocked.

5.3.3 Manual control

At least the temperature control device on the oil side and flow monitoring are to remain operative in manual operation.

5.3.4 Leakage monitoring

Oil tanks are to be equipped with a leakage detector which, when actuated, shuts down and interlocks the thermal oil firing system. If the oil fired heater is on standby, the starting of the burner is to be blocked if the leakage detector is actuated.

5.4 Control and monitoring

5.4.1 In addition to those of this item [5.4], the general requirements given in Chapter 3 apply.

In the case of ships with automation notations, the requirements in Pt F Ch 3 also apply.

5.4.2 Tab 19, Tab 19, and Tab 20 summarise the control and monitoring requirements for main propulsion boilers, auxiliary boilers, oil fired thermal oil heaters and exhaust gas thermal oil heaters and incinerators, respectively.

Note 1: Some departures from Tab 19, Tab 19, Tab 20 and Tab 21 may be accepted by the Society in the case of ships with a restricted navigation notation.

6 Arrangement and installation

6.1 Foundations

6.1.1 For boilers and pressure vessels bolting down to their foundations, see Sec 1, [3.3.1]. Where necessary, they are

also to be secured to the adjacent hull structures by suitable ties.

Where chocks are required to be fitted between the boilers and their foundations, they are to be of cast iron or steel.

6.2 Boilers

6.2.1 Thermal expansion

Means are to be provided to compensate thermal expansion of boilers.

6.2.2 Minimum distance of boilers from vertical bulkheads and fuel tanks

- The distance between boilers and vertical bulkheads is to be not less than the minimum distance necessary to provide access for inspection and maintenance of the structure adjacent to the boiler.
- In addition to the requirement in a), the distance of boilers from fuel oil tanks is to be such as to prevent the possibility that the temperature of the tank bulkhead may approach the flash point of the oil.
- In any event, the distance between a boiler and a vertical bulkhead is not to be less than 450 mm.

Table 19 : Auxiliary boilers

Symbol convention H = High, HH = High high, G = group alarm L = Low, LL = Low low, I = individual alarm X = function is required, R = remote	Monitoring		Automatic control				
			Boiler			Auxiliary	
Identification of system parameter	Alarm	Indication	Slow-down	Shut-down	Control	Stand by Start	Stop
Water level	L+H	local					
	LL			X			
Circulation stopped (when forced circulation boiler)	X			X			
Fuel oil temperature or viscosity (2)	L+H	local					
Flame failure	X			X			
Temperature in boiler casing (Fire)	H						
Steam pressure	H (1)	local		X			
(1) When the automatic control does not cover the entire load range from zero load							
(2) Where heavy fuel is used							

Table 20 : Thermal oil system

Symbol convention H = High, HH = High high, G = group alarm L = Low, LL = Low low, I = individual alarm X = function is required, R = remote	Monitoring		Automatic control				
			System			Auxiliary	
Identification of system parameter	Alarm	Indication	Slow-down	Shut-down	Control	Stand by Start	Stop
Thermal fluid temperature heater outlet	H	local		X			
Thermal fluid pressure pump discharge	H	local		X			
Thermal fluid flow through each heating element	L	local		X			
Expansion tank level	L	local		X (1)			
(1) Stop of burner and fluid flow							
(2) Stop of the flue gas only							

Symbol convention H = High, HH = High high, G = group alarm L = Low, LL = Low low, I = individual alarm X = function is required, R = remote	Monitoring		Automatic control				
			System			Auxiliary	
Identification of system parameter	Alarm	Indica- tion	Slow- down	Shut- down	Control	Stand by Start	Stop
Expansion tank temperature	H						
Forced draft fan stopped	X			X			
Heavy fuel oil temperature or viscosity	H+L	local					
Burner flame failure	X			X			
Flue gas temperature heater inlet (When exhaust gas heater)	H			X (2)			
(1) Stop of burner and fluid flow							
(2) Stop of the flue gas only							

Table 21 : Incinerators

Symbol convention H = High, HH = High high, G = group alarm L = Low, LL = Low low, I = individual alarm X = function is required, R = remote	Monitoring		Automatic control				
			Incinerator			Auxiliary	
Identification of system parameter	Alarm	Indica- tion	Slow- down	Shut- down	Control	Stand by Start	Stop
Flame failure	X			X			
Furnace temperature	H			X			
Exhaust gas temperature	H						
Fuel oil pressure		local					
Fuel oil temperature or viscosity (1)	H+L	local					
(1) Where heavy fuel is used							

6.2.3 Minimum distance of boilers from double bottom

a) Where double bottoms in way of boilers may be used to carry fuel oil, the distance between the top of the double bottom and the lower metal parts of the boilers is not to be less than:

- 600 mm, for cylindrical boilers
- 750 mm, for water tube boilers.

b) The minimum distance of vertical tube boilers from double bottoms not intended to carry oil may be 200 mm.

6.2.4 Minimum distance of boilers from ceilings

- a) A space sufficient for adequate heat dissipation is to be provided on the top of boilers.
- b) Oil tanks are not permitted to be installed in spaces above boilers.

6.2.5 Drip trays and gutterways

Boilers are to be fitted with drip trays and gutterways in way of burners so arranged as to prevent spilling of oil into the bilge.

6.2.6 Hot surfaces

Hot surfaces with which the crew are likely to come into contact during operation are to be suitably guarded or insulated. See Sec 1, [3.11.1].

6.2.7 Registers fitted in the smoke stacks of oil fired boilers

Where registers are fitted in smoke stacks, they are not to obstruct more than two thirds of the cross-sectional area of gas passage when closed. In addition, they are to be provided with means for locking them in open position when the boiler is in operation and for indicating their position and degree of opening.

6.3 Pressure vessels

6.3.1 Safety devices on multiple pressure vessels

Where two or more pressure vessels are interconnected by a piping system of adequate size so that no branch of piping may be shut off, it is sufficient to provide them with one safety valve and one pressure gauge only.

6.4 Thermal oil heaters

6.4.1 In general, the requirements of [6.2] for boilers are also applicable to thermal oil heaters.

7 Material test, workshop inspection and testing, certification

7.1 Material testing

7.1.1 General

Materials, including welding consumables, for the constructions of boilers and pressure vessels are to be certified by the material manufacturer in accordance with the appropriate material specification.

7.1.2 Boilers, other steam generators, and oil fired and exhaust gas thermal oil heaters

In addition to the requirement in [7.1.1], testing of materials intended for the construction of pressure parts of boilers, other steam generators, oil fired thermal oil heaters and exhaust gas thermal oil heaters is to be witnessed by the Surveyor.

7.1.3 Class 1 pressure vessels and heat exchangers

In addition to the requirement in [7.1.1], testing of materials intended for the construction of pressure parts of class 1 pressure vessels and heat exchangers is to be witnessed by the Surveyor.

This requirement may be waived at the Society's discretion for mass produced small pressure vessels (such as accumulators for valve controls, gas bottles, etc.).

7.2 Workshop inspections

7.2.1 Boilers and individually produced class 1 and 2 pressure vessels

The construction, fitting and testing of boilers and individually produced class 1 and 2 pressure vessels are to be attended by the Surveyor, at the builder's facility.

7.2.2 Mass produced pressure vessels

Construction of mass produced pressure vessels which are type approved by the Society need not be attended by the Surveyor.

7.3 Hydrostatic tests

7.3.1 General

Hydrostatic tests of all class 1, 2 and 3 pressure vessels are to be witnessed by the Surveyor with the exception of mass produced pressure vessels which are built under the conditions stated in [7.2.2].

7.3.2 Testing pressure

- a) Upon completion, pressure parts of boilers and pressure vessels are to be subjected to a hydraulic test under a pressure p_t defined below as a function of the design pressure p :
 - $p_t = 1,5 p$ where $p \leq 4 \text{ MPa}$
 - $p_t = 1,4 p + 0,4$ where $4 \text{ MPa} < p \leq 25 \text{ MPa}$
 - $p_t = p + 10,4$ where $p > 25 \text{ MPa}$
- b) The test pressure may be determined as a function of a pressure lower than p ; however, in such case, the setting and characteristics of the safety valves and other over-

pressure protective devices are also to be determined and blocked as a function of this lower pressure.

- c) If the design temperature exceeds 300°C, the test pressure p_t is to be as determined by the following formula:

$$p_t = 1,5 \cdot \frac{K_{100}}{K} \cdot p$$

where:

- p : Design pressure, in MPa
- K_{100} : Permissible stress at 100°C, in N/mm²
- K : Permissible stress at the design temperature, in N/mm²

- d) Consideration is to be given to the reduction of the test pressure below the values stated above where it is necessary to avoid excessive stress. In any event, the general membrane stress is not to exceed 90% of the yield stress at the test temperature.
- e) Economisers which cannot be shut off from the boiler in any working condition are to be submitted to a hydraulic test under the same conditions as the boilers.
- f) Economisers which can be shut off from the boiler are to be submitted to a hydraulic test at a pressure determined as a function of their actual design pressure p .

7.3.3 Hydraulic test of boiler and pressure vessel accessories

- a) Boilers and pressure vessel accessories are to be tested at a pressure p_t which is not less than 1,5 times the design pressure p of the vessels to which they are attached.
- b) The test pressure may be determined as a function of a pressure lower than p ; however, in such case, the setting and characteristics of the safety valves and other over-pressure protective devices are also to be determined and blocked as a function of this lower pressure.

7.3.4 Hydraulic test procedure

- a) The hydraulic test specified in [7.3.1] is to be carried out after all openings have been cut out and after execution of all welding work and of the heat treatment, if any. The vessel to be tested is to be presented without lagging, paint or any other lining and the pressure is to be maintained long enough for the Surveyor to proceed with a complete examination.
- b) Hydraulic tests of boilers are to be carried out either after installation on board, or at the manufacturer's plant. Where a boiler is hydrotested before installation on board, the Surveyor may, if deemed necessary, request to proceed with a second hydraulic test on board under a pressure at least equal to 1,1 p . For this test, the boiler may be fitted with its lagging. However, the Surveyor may require this lagging to be partially or entirely removed as necessary.
- c) For water tube boilers, the hydraulic test may also be carried out separately for different parts of the boiler upon their completion and after heat treatment. For drums and headers, this test may be carried out before drilling the tube holes, but after welding of all appendices and heat treatment. When all parts of the boiler have been separately tested and following assembly the

boiler is to undergo a hydraulic test under a pressure of 1,25 p.

7.3.5 Hydraulic tests of condensers

Condensers are to be subjected to a hydrostatic test at the following test pressures:

- Steam space: 0,1 MPa
- Water space: maximum pressure which may be developed by the pump with closed discharge valve increased by 0,07 MPa. However, the test pressure is not to be less than 0,2 MPa. When the characteristics of the pump are not known, the hydrostatic test is to be carried out at a pressure not less than 0,35 MPa.

7.4 Certification

7.4.1 Certification of boilers and individually produced pressure vessels

Boilers and individually produced pressure vessels of classes 1 and 2 are to be certified by the Society in accordance with the procedures stated in Part D.

7.4.2 Mass produced pressure vessels

Small mass produced pressure vessels of classes 1 and 2 may be accepted provided they are type approved by the Society in accordance with the procedures stated in Part A.

7.4.3 Pressure vessels not required to be certified

The Manufacturer's certificate, including detail of tests and inspections, is to be submitted to the Society for pressure vessels not required to be certified by the Society. The Society reserves the right to require confirmatory hydrostatic tests in the presence of the Surveyor on a case by case basis, based on the criticality and service of the pressure vessel.

SECTION 4 GEARING

1 General

1.1 Application

1.1.1 Unless otherwise specified, the requirements of this section apply to:

- reduction and/or reverse gears intended for propulsion plants with a transmitted power of 220 kW and above
- other reduction and step-up gears with a transmitted power of 110 kW and above, intended for essential service auxiliary machinery.

All other gears are to be designed and constructed according to sound marine practice and delivered with the relevant works' certificate (see Pt D, Ch 1, Sec 1, [4.2.3]).

The provisions of Article [2] apply only to cylindrical involute spur or helical gears with external or internal teeth.

Additional requirements for gears fitted to ships having an ice notation are given in Part F, Chapter 9.

Some departure from the requirements of this Section may be accepted by the Society in cases of gears fitted to ships having a restricted navigation notation.

Alternative calculations based on a recognized standard may be submitted by the manufacturer of the gears and will be given special consideration by the Society.

1.2 Documentation to be submitted

1.2.1 Documents

Before starting construction, all plans, specifications and calculations listed in Tab 1 are to be submitted to the Society.

Table 1 : Documents to be submitted for gearing

No.	I/A (1)	Document (2)
1	A	Constructional drawings of shafts and flanges
2	A	Constructional drawings of pinions and wheels, including: <ul style="list-style-type: none"> a) specification and details of hardening procedure: <ul style="list-style-type: none"> • core and surface mechanical characteristics • diagram of the depth of the hardened layer as a function of hardness values b) specification and details of the finishing procedure: <ul style="list-style-type: none"> • finishing method of tooth flanks (hobbing, shaving, lapping, grinding, shot-peening) • surface roughness for tooth flank and root fillet • tooth flank corrections (helix modification, crowning, tip-relief, end-relief), if any • grade of accuracy according to ISO 1328-1 1997
3	A	Shrinkage calculation for shrunk-on pinions, wheels rims and/or hubs with indication of the minimum and maximum shrinkage allowances
4	A	Calculation of load capacity of the gears
5	A / I (3)	Constructional drawings of casings
6	A	Functional diagram of the lubricating system, with indication of: <ul style="list-style-type: none"> • specified grade of lubricating oil • expected oil temperature in service • kinematic viscosity of the oil
7	A	Functional diagram of control, monitoring and safety systems
8	I	Longitudinal and transverse cross-sectional assembly of the gearing, with indication of the type of clutch
9	I	Data form for calculation of gears
<p>(1) A = to be submitted for approval, in four copies I = to be submitted for information, in duplicate.</p> <p>(2) Constructional drawings are to be accompanied by the specification of the materials employed including the chemical composition, heat treatment and mechanical properties and, where applicable, the welding details, welding procedure and stress relieving procedure.</p> <p>(3) "A" for welded casing, "I" otherwise</p>		

1.2.2 Data

The data listed in Tab 2 are to be submitted with the documents required in [1.2.1].

Table 2 : Data to be submitted for gearing

No.	Description of the data
1	Type of driving and driven machines and, if provided, type of flexible coupling
2	Maximum power transmitted by each pinion in continuous running and corresponding rotational speed, for all operating conditions, including clutching-in
3	Modules of teeth for pinion and wheels
4	Pressure angle and helix angle
5	Tooth profiles of pinions and wheels together with tip diameters and fillet radii
6	Operating centre distance
7	Addendum of the cutting tool
8	Common face width, operating pitch diameter
9	Data related to the bearings: <ul style="list-style-type: none"> • type, characteristics and designed service life of roller bearings • materials and clearances of plain bearings • position of each gear in relation to its bearings
10	Torsional vibration data (inertia and stiffness)

2 Design of gears - Determination of the load capacity

2.1 Symbols, units, definitions

2.1.1 Symbols and units

The meaning of the main symbols used in this Section is specified below.

Other symbols introduced in connection with the definition of influence factors are defined in the appropriate articles.

- a : Operating centre distance, in mm
- b : Common face width (for double helix gear, width of one helix), in mm
- d : Reference diameter, in mm
- d_a : Tip diameter, in mm
- d_b : Base diameter, in mm
- d_f : Root diameter, in mm
- d_w : Working pitch diameter, in mm
- x : Addendum modification coefficient
- z : Number of teeth
- z_n : Virtual number of teeth

- n : Rotational speed, in rpm
- U : Reduction ratio
- m_n : Normal module, in mm
- h : Tooth depth, in mm
- α_{Fen} : Load direction angle, relevant to direction of application of load at the outer point of single pair tooth contact of virtual spur gear, in rad
- α_n : Normal pressure angle at reference cylinder, in rad
- α_t : Transverse pressure angle at reference cylinder, in rad
- α_{tw} : Transverse pressure angle at working pitch cylinder, in rad
- β : Helix angle at reference cylinder, in rad
- β_b : Base helix angle, in rad.
- ε_α : Transverse contact ratio
- ε_β : Overlap ratio
- ε_γ : Total contact ratio
- ρ_{ao} : Tip radius of the tool,
- ρ_F : Tooth root radius at the critical section, in mm
- h_{Fe} : Bending moment relevant to the load application at the outer point of single pair tooth contact, in mm
- h_{ip} : Basic rack dedendum, in mm
- s_{Fn} : Tooth root chord at critical section, in mm
- χ_B : Running-in factor (mesh misalignment)
- Q : Gearing quality class according to ISO 1328-1 1997
- HB : Brinell Hardness
- HV : Vickers hardness
- R : Minimum tensile strength of gear material, in N/mm²
- R_{z(f)} : Mean flank peak-to-valley roughness, in μm
- R_{z(f)} : Mean root peak-to-valley roughness, in μm
- F_t : Nominal tangential load, in N
- σ_F : Tooth root bending stress, in N/mm²
- σ_{FE} : Endurance limit for tooth root bending stress, in N/mm²
- σ_{FP} : Permissible tooth root bending stress, in N/mm²
- σ_H : Contact stress (Hertzian pressure), in N/mm²
- σ_{H,lim} : Endurance limit for contact stress (Hertzian pressure), in N/mm²
- σ_{HP} : Permissible contact stress (Hertzian pressure), in N/mm²
- v : Linear speed at working pitch diameter, in m/s

Subscripts:

- 1 for pinion, i.e. the gear having the smaller number of teeth
- 2 for wheel.

2.1.2 Geometrical definitions

In the calculation of surface durability, b is the common face width on the working pitch diameter.

In tooth strength calculations, b_1, b_2 are the face widths at the respective tooth roots. In any case b_1 and b_2 are not to be taken as greater than b by more than one module (m_n) on either side

For internal gears, $z_2, a, d_2, d_{a2}, d_{b2}$ and d_{w2} are to be taken negative.

$$u = \frac{z_2}{z_1}$$

Note 1: $u > 0$ for external gears, $u < 0$ for internal gears.

$$\tan \alpha_t = \frac{\tan \alpha_n}{\cos \beta}$$

$$d = \frac{z \cdot m_n}{\cos \beta}$$

$$d_b = d \cdot \cos \alpha_t$$

$$\cos \alpha_{tw} = \frac{d_{b1} + d_{b2}}{2a}$$

$$\tan \beta_b = \tan \beta \cdot \cos \alpha_t$$

$$\text{inv } \alpha = \tan \alpha - \alpha$$

for external gears:

$$\varepsilon_\alpha = \frac{0,5 \cdot (d_{a1}^2 - d_{b1}^2)^{\frac{1}{2}} + 0,5 \cdot (d_{a2}^2 - d_{b2}^2)^{\frac{1}{2}} - (a \cdot \sin \alpha_{tw})}{\frac{\pi \cdot m_n \cdot \cos \alpha_t}{\cos \beta}}$$

for internal gears:

$$\varepsilon_\alpha = \frac{0,5 \cdot (d_{a1}^2 - d_{b1}^2)^{\frac{1}{2}} - 0,5 \cdot (d_{a2}^2 + d_{b2}^2)^{\frac{1}{2}} - (a \cdot \sin \alpha_{tw})}{\frac{\pi \cdot m_n \cdot \cos \alpha_t}{\cos \beta}}$$

$$\varepsilon_\beta = \frac{b \cdot \sin \beta}{\pi \cdot m_n}$$

$$\varepsilon_\gamma = \varepsilon_\alpha + \varepsilon_\beta$$

2.2 Principle

2.2.1

a) The following requirements apply to cylindrical involute spur or helical gears with external or internal teeth, and provide a method for the calculation of the load capacity with regard to:

- the surface durability (contact stress), and
- the tooth root bending stress.

The relevant formulae are provided in [2.4] and [2.5].

The influence factors common to the formulae are given in [2.3].

b) Gears for which the conditions of validity of some factors or formulae are not satisfied will be given special consideration by the Society.

c) Other methods of determination of load capacity will be given special consideration by the Society.

2.3 General influence factors

2.3.1 General

General influence factors are defined in [2.3.2], [2.3.3], [2.3.4], [2.3.5], [2.3.6] and [2.3.7]. Alternative values may be used provided they are derived from appropriate measurements.

2.3.2 Application factor K_A

The application factor K_A accounts for dynamic overloads from sources external to the gearing.

The values of K_A are given in Tab 3.

Table 3 : Values of K_A

Type of installation		K_A	
Main gears (propulsion)	Diesel engine	with hydraulic coupling	1,00
		with elastic coupling	1,30
		with other type of coupling	1,50
	Electric motor	1,00	
Auxiliary gears	Diesel engine	with hydraulic coupling	1,00
		with elastic coupling	1,20
		with other type of coupling	1,40
	Electric motor	1,00	

2.3.3 Load sharing factor K_γ

The load sharing factor K_γ accounts for the uneven sharing of load on multiple path transmissions, such as epicyclic gears or tandem gears.

The values of K_γ are given in Tab 4.

Table 4 : Values of K_γ

Type of gear		K_γ
Dual tandem gear	without quill shaft (1)	1,15
	with quill shaft (1)	1,10
Epicyclic gear	with 3 planetary gears and less	1,00
	with 4 planetary gears	1,20
	with 5 planetary gears	1,30
	with 6 planetary gears and more	1,40
(1) A quill shaft is a torsionally flexible shaft intended for improving the load distribution between the gears.		

2.3.4 Dynamic factor K_V

The dynamic factor K_V accounts for the additional internal dynamic loads acting on the tooth flanks and due to the vibrations of pinion and wheel.

The values of K_V are given in Tab 5. They apply only to steel gears of heavy rim sections with:

$$\frac{F_t}{b} > 150$$

$$z_1 < 50$$

Table 5 : Values of K_V

Type of gear	K_V		Limitations
Spur gear	$K_V = K_{V2}$ with: $K_{V2} = 1 + K_1 \cdot \frac{v \cdot Z_1}{100}$ where K_1 has the values specified in Tab 6		$\frac{v \cdot Z_1}{100} < 10$
Helical gear	• if $\epsilon_\beta \geq 1$:	$K_V = K_{V1}$ with: $K_{V1} = 1 + K_1 \cdot \frac{v \cdot Z_1}{100}$ where K_1 has the values specified in Tab 6	$\frac{v \cdot Z_1}{100} < 14$
	• if $\epsilon_\beta < 1$:	$K_V = K_{V2} - \epsilon_\beta \cdot (K_{V2} - K_{V1})$ where K_{V2} is calculated as if the gear were of spur type	

Table 6 : Values of K_1

Type of gear	ISO grade of accuracy (1)					
	3	4	5	6	7	8
Spur gear	0,022	0,030	0,043	0,062	0,092	0,125
Helical gear	0,0125	0,0165	0,0230	0,0330	0,0480	0,0700

(1) ISO grade of accuracy according to ISO 1328-1 1997. In case of mating gears with different grades of accuracy, the grade corresponding to the lower accuracy is to be used.

For gears not complying with the above given limitations or with the limitations given in Tab 5 the value of K_V shall be submitted by the manufacturer of the gears and will be given special consideration by the Society.

2.3.5 Face load distribution factors $K_{H\beta}$ and $K_{F\beta}$

- a) The face load distribution factors, $K_{H\beta}$ for contact stress and $K_{F\beta}$ for tooth root bending stress, account for the effects of non-uniform distribution of load across the face width.
- b) The values of $K_{H\beta}$ and $K_{F\beta}$ are to be determined according to method C2 of ISO 6336-1 and apply only to gears having:
 - wheel, case, wheel shaft and bearings of stiff construction
 - pinion on a solid or hollow shaft with an inner to outer diameter ratio not exceeding 0,5, and located symmetrically between the bearings
 - no external loads acting on the pinion shaft.

$$K_{H\beta} = 1 + (F_{\beta y} \cdot C_\gamma \cdot b) / (2 \cdot F_m) \quad \text{for } K_{H\beta} \leq 2$$

$$K_{H\beta} = \sqrt{2 \cdot F_{\beta y} \cdot C_\gamma \cdot b / F_m} \quad \text{for } K_{H\beta} > 2$$

where:

$F_{\beta y}$: effective equivalent misalignment after running in, in μm ;

C_γ : mesh stiffness, see [2.3.7];

F_m : mean transverse tangential load at the reference circle relevant to mesh calculation,

$$F_m = F_t \cdot K_A \cdot K_V$$

Note 1: For gears for which the above given conditions are not satisfied the value of $K_{H\beta}$ shall be submitted by the manufacturer of the gears and will be special consideration by the Society.

- c) $K_{F\beta}$ is to be determined using the following formula:

$$K_{F\beta} = \frac{1}{K_{H\beta}^{1 + h/b + (h/b)^2}}$$

where b/h is the smaller of b_1/h_1 and b_2/h_2 but is not to be taken lower than 3.

In case of end relief or crowing: $K_{F\beta} = K_{H\beta}$

2.3.6 Transverse load distribution factors $K_{H\alpha}$ and $K_{F\alpha}$

The transverse load distribution factors, $K_{H\alpha}$ for contact stress, and $K_{F\alpha}$ for tooth root bending stress, account for the effects of pitch and profile errors on the transversal load distribution between two or more pairs of teeth in mesh.

The values of $K_{H\alpha}$ and $K_{F\alpha}$ are given in Tab 7, complying with method B of ISO 6336-1.

2.3.7 Mesh stiffness c_γ

The value of the mesh stiffness c_γ shall be submitted by the manufacturer of the gears and will be given special consideration by the Society. Alternatively it will be assumed:

$$c_\gamma = 20\text{N}/(\text{mm} \cdot \mu\text{m})$$

Table 7 : Values of $K_{H\alpha}$ and $K_{F\alpha}$

Total contact ratio ε_γ	Transverse load distribution factors $K_{H\alpha}$ and $K_{F\alpha}$	Limitations
$\varepsilon_\gamma \leq 2$	$K_{H\alpha} = K_{F\alpha} = \frac{\varepsilon_\gamma}{2} \cdot \left(0,9 + 0,4 \cdot \frac{c_\gamma \cdot b \cdot (f_{pb} - y_\alpha)}{F_{tH}} \right)$	$K_{H\alpha} = K_{F\alpha} \geq 1 \quad (1)$ $K_{H\alpha} \leq \frac{\varepsilon_\gamma}{\varepsilon_\alpha \cdot Z_\varepsilon^2} \quad (2)$ $K_{F\alpha} \leq \frac{\varepsilon_\gamma}{\varepsilon_\alpha \cdot Y_\varepsilon} \quad (3)$
$\varepsilon_\gamma > 2$	$K_{H\alpha} = K_{F\alpha} = 0,9 + 0,4 \cdot \sqrt{\frac{2 \cdot (\varepsilon_\gamma - 1)}{\varepsilon_\gamma}} \cdot \frac{c_\gamma \cdot b \cdot (f_{pb} - y_\alpha)}{F_{tH}}$	
where: c_γ : Mesh stiffness, as defined in [2.3.7] f_{pb} : Maximum base pitch deviation of the wheel, in μm (4) y_α : Running-in allowance, in μm F_{tH} : determinant tangent load in a transverse plane, $F_{tH} = F_t \cdot K_A \cdot K_V \cdot K_{H\beta}$		
(1) Where $K_{H\alpha} = K_{F\alpha} < 1$, then take $K_{H\alpha} = K_{F\alpha} = 1$ (2) Where $K_{H\alpha} > \varepsilon_\gamma / (\varepsilon_\alpha \cdot Z_\varepsilon^2)$, then take $K_{H\alpha} = \varepsilon_\gamma / (\varepsilon_\alpha \cdot Z_\varepsilon^2)$ (3) Where $K_{F\alpha} > \varepsilon_\gamma / (\varepsilon_\alpha \cdot Y_\varepsilon)$, then take $K_{F\alpha} = \varepsilon_\gamma / (\varepsilon_\alpha \cdot Y_\varepsilon)$ (4) In cases of optimum profile correction, f_{pb} is to be replaced by $f_{pb} / 2$		

2.4 Calculation of surface durability

2.4.1 General

The criterion for surface durability is based on the contact stress (Hertzian pressure) on the pitch point or at the inner point of single pair contact.

The contact stress σ_H is not to exceed the permissible contact stress σ_{HP} .

2.4.2 Contact stress σ_H

The contact stress σ_H is to be determined as follows.

- for the pinion

$$\sigma_H = Z_B \cdot \sigma_{H0} \sqrt{K_A \cdot K_\gamma \cdot K_V \cdot K_{H\beta} \cdot K_{H\alpha}}$$

- for the wheel

$$\sigma_H = Z_D \cdot \sigma_{H0} \sqrt{K_A \cdot K_\gamma \cdot K_V \cdot K_{H\beta} \cdot K_{H\alpha}}$$

where:

σ_{H0} : calculated from the following formulae:
for external gears:

$$\sigma_{H0} = Z_H \cdot Z_E \cdot Z_\varepsilon \cdot Z_\beta \sqrt{\frac{F_t}{d_1 \cdot b} \cdot \frac{u+1}{u}}$$

for internal gears:

$$\sigma_{H0} = Z_H \cdot Z_E \cdot Z_\varepsilon \cdot Z_\beta \sqrt{\frac{F_t}{d_1 \cdot b} \cdot \frac{u-1}{u}}$$

K_A : Application factor (see [2.3.2]),

K_γ : Load sharing factor (see [2.3.3]),

K_V : Dynamic factor (see [2.3.4]),

$K_{H\beta}$: Face load distribution factors (see [2.3.5]),

$K_{H\alpha}$: Transverse load distribution factors (see [2.3.6]),

Z_B : Single pair mesh factor for pinion (see [2.4.4]),

Z_D : Single pair mesh factor for wheel (see [2.4.4]),

Z_H : Zone factor (see [2.4.5]),

Z_E : Elasticity factor (see [2.4.6]),

Z_ε : Contact ratio factor (see [2.4.7]),

Z_β : Helix angle factor (see [2.4.8]).

2.4.3 Permissible contact stress σ_{HP}

The permissible contact stress σ_{HP} is to be determined separately for pinion and wheel using the following formula:

$$\sigma_{HP} = \frac{\sigma_{H,lim}}{S_H} \cdot Z_L \cdot Z_V \cdot Z_R \cdot Z_W \cdot Z_X \cdot Z_N$$

where:

Z_L : Lubricant factor (see [2.4.9]),

Z_V : Speed factor (see [2.4.9]),

Z_R : Roughness factor (see [2.4.9]),

Z_W : Hardness ratio factor (see [2.4.10]),

Z_X : Size factor for contact stress (see [2.4.11]),

Z_N : Life factor for contact stress, assumed equal to Z_{NT} according to method B of ISO 6336-2, or assumed to be 1,

S_H : Safety factor for contact stress (see [2.4.12]).

2.4.4 Single pair mesh factors Z_B and Z_D

The single pair mesh factors Z_B for pinion and Z_D for wheel account for the influence on contact stresses of the tooth flank curvature at the inner point of single pair contact in relation to Z_H . These factors transform the contact stress determined at the pitch point to contact stresses considering the flank curvature at the inner point of single pair contact.

Z_B and Z_D are to be determined as follows:

a) for spur gears ($\epsilon_\beta = 0$):

- $Z_B = M_1$ or 1, whichever is the greater, where

$$M_1 = \frac{\tan \alpha_{tw}}{\sqrt{\left[\sqrt{\left(\frac{d_{a1}}{d_{b1}} \right)^2 - 1} - \frac{2\pi}{z_1} \right] \cdot \left[\sqrt{\left(\frac{d_{a2}}{d_{b2}} \right)^2 - 1} - (\epsilon_\alpha - 1) \frac{2\pi}{z_2} \right]}}$$

- $Z_D = M_2$ or 1, whichever is the greater, where

$$M_2 = \frac{\tan \alpha_{tw}}{\sqrt{\left[\sqrt{\left(\frac{d_{a2}}{d_{b2}} \right)^2 - 1} - \frac{2\pi}{z_2} \right] \cdot \left[\sqrt{\left(\frac{d_{a1}}{d_{b1}} \right)^2 - 1} - (\epsilon_\alpha - 1) \frac{2\pi}{z_1} \right]}}$$

b) for helical gears:

- with $\epsilon_\beta \geq 1$: $Z_B = Z_D = 1$.
- with $\epsilon_\beta < 1$: Z_B and Z_D are to be determined by linear interpolation between:
 - Z_B and Z_D for spur gears, and
 - Z_B and Z_D for helical gears with $\epsilon_\beta \geq 1$,

thus

- $Z_B = M_1 - \epsilon_\beta (M_1 - 1)$ and $Z_B \geq 1$
- $Z_D = M_2 - \epsilon_\beta (M_2 - 1)$ and $Z_D \geq 1$

2.4.5 Zone factor Z_H

The zone factor Z_H accounts for the influence on the Hertzian pressure of tooth flank curvature at the pitch point and transforms the tangential force at the reference cylinder to normal force at the pitch cylinder.

Z_H is to be determined as follows:

$$Z_H = \frac{\sqrt{2 \cdot \cos \beta_b \cdot \cos \alpha_{tw}}}{\sqrt{(\cos \alpha_t)^2 \cdot \sin \alpha_{tw}}}$$

2.4.6 Elasticity factor Z_E

The elasticity factor Z_E accounts for the influence of the metal properties (module of elasticity E and Poisson's ratio ν) on the Hertzian pressure.

For steel gears, $Z_E = 189,8 \text{ N}^{1/2}/\text{mm}$.

2.4.7 Contact ratio factor Z_ϵ

The contact ratio factor Z_ϵ accounts for the influence of the transverse contact ratio and the overlap ratio on the specific surface load of gears.

Z_ϵ is to be determined as follows:

a) for spur gears:

$$Z_\epsilon = \sqrt{\frac{4 - \epsilon_\alpha}{3}}$$

b) for helical gears:

- for $\epsilon_\beta < 1$

$$Z_\epsilon = \sqrt{\frac{4 - \epsilon_\alpha}{3} \cdot (1 - \epsilon_\beta) + \frac{\epsilon_\beta}{\epsilon_\alpha}}$$

- for $\epsilon_\beta \geq 1$

$$Z_\epsilon = \sqrt{\frac{1}{\epsilon_\alpha}}$$

2.4.8 Helix angle factor Z_β

The helix angle factor Z_β accounts for the influence of helix angle on surface durability, allowing for such variables as the distribution of load along the lines of contact.

Z_β is to be determined as follows:

$$Z_\beta = \sqrt{\cos \beta}$$

2.4.9 Lubrication, speed and roughness factors Z_L , Z_V and Z_R

The lubricant factor Z_L accounts for the influence of the type of the lubricant and of its viscosity, the speed factor Z_V accounts for the influence of the pitch line velocity, and the roughness factor Z_R accounts for the influence of the surface roughness on the surface endurance capacity.

These factors are to be determined as follows:

a) Lubricant factor Z_L

$$Z_L = C_{ZL} + \frac{4 \cdot (1,0 - C_{ZL})}{\left(1,2 + \frac{134}{v_{40}}\right)^2}$$

where:

v_{40} : nominal kinematic viscosity of the oil at 40°C, mm²/s

C_{ZL} : • for $\sigma_{H,lim} < 850 \text{ N/mm}^2$

$$C_{ZL} = 0,83$$

- for $850 \text{ N/mm}^2 \leq \sigma_{H,lim} \leq 1200 \text{ N/mm}^2$

$$C_{ZL} = \frac{\sigma_{H,lim}}{4375} + 0,6357$$

- for $\sigma_{H,lim} > 1200 \text{ N/mm}^2$

$$C_{ZL} = 0,91$$

b) Speed factor Z_V

$$Z_V = C_{ZV} + \frac{2 \cdot (1,0 - C_{ZV})}{\sqrt{0,8 + \frac{32}{v}}}$$

where:

- for $\sigma_{H,lim} < 850 \text{ N/mm}^2$

$$C_{ZV} = 0,85$$

- for $850 \text{ N/mm}^2 \leq \sigma_{H,lim} \leq 1200 \text{ N/mm}^2$

$$C_{ZV} = \frac{\sigma_{H,lim}}{4375} + 0,6557$$

- for $\sigma_{H,lim} > 1200 \text{ N/mm}^2$

$$C_{ZV} = 0,93$$

c) Roughness factor Z_R

$$Z_R = \left(\frac{3}{R_{Z10(f)}} \right)^{C_{ZR}}$$

where:

$R_{Z10(f)}$: Mean relative flank peak-to-valley roughness for the gear pair

$$R_{Z10(f)} = R_{Z(f)} \sqrt[3]{\frac{10}{\rho_{red}}}$$

$R_{Z(f)}$: Mean flank peak-to-valley roughness of the gear pair,

$$R_{Z(t)} = \frac{R_{Z(t)1} + R_{Z(t)2}}{2}$$

ρ_{red} : Relative radius of curvature, equal to:

$$\rho_{red} = \frac{\rho_1 \cdot \rho_2}{\rho_1 + \rho_2} \quad \text{with:}$$

$$\rho_1 = 0,5 \cdot d_{b1} \cdot \tan \alpha_{tw}$$

$$\rho_2 = 0,5 \cdot d_{b2} \cdot \tan \alpha_{tw}$$

d_b being taken negative for internal gears,

C_{ZR} : Coefficient having the following values:

- for $\sigma_{H,lim} < 850 \text{ N/mm}^2$

$$C_{ZR} = 0,15$$

- for $850 \text{ N/mm}^2 \leq \sigma_{H,lim} \leq 1200 \text{ N/mm}^2$

$$C_{ZR} = 0,32 - \frac{\sigma_{H,lim}}{5000}$$

- for $\sigma_{H,lim} > 1200 \text{ N/mm}^2$

$$C_{ZR} = 0,08$$

2.4.10 Hardness ratio factor Z_W

The hardness ratio factor Z_W accounts for the increase of surface durability in the case of a through-hardened wheel meshing with a surface-hardened or significantly ($\geq 200\text{HV}$) harder pinion having a smooth tooth surface ($R_{Z(t)} \leq 6\mu\text{m}$). Z_W applies to the soft wheel only, and is to be determined as follows:

- for $\text{HB} < 130$

$$Z_W = 1,2$$

- for $130 \leq \text{HB} \leq 470$

$$Z_W = 1,2 - \frac{\text{HB} - 130}{1700}$$

- for $\text{HB} > 470$

$$Z_W = 1,0$$

where HB is the Brinell hardness of the soft wheel.

2.4.11 Size factor Z_X

The size factor Z_X accounts for the influence of tooth dimensions on permissible contact stress and reflects the non-uniformity of material properties.

Z_X is to be determined as follows:

- for through-hardened steel: $Z_X = 1$

- for nitrided or nitrocarburised steel:

$$Z_X = 1,08 - 0,011 m_n \quad \text{with } 0,75 \leq Z_X \leq 1$$

- for case-hardened steels:

$$Z_X = 1,05 - 0,005 m_n \quad \text{with } 0,90 \leq Z_X \leq 1$$

2.4.12 Safety factor for contact stress S_H

The values to be adopted for the safety factor for contact stress S_H are given in Table 8.

Table 8 : Safety factor for contact stress S_H

Type of installation		S_H
Main gears (propulsion)	single machinery	1,25
	duplicate machinery	1,20
Auxiliary gears		1,15

2.4.13 Endurance limit for contact stress $\sigma_{H,lim}$

The endurance limit for contact stress $\sigma_{H,lim}$ is the limit of repeated contact stress which can be permanently endured.

The values to be adopted for $\sigma_{H,lim}$ are given in Table 9 in relation to the type of steel employed and the heat treatment performed, unless otherwise documented according to recognised standards.

Table 9 : Endurance limit for contact stress $\sigma_{H,lim}$

Type of steel and heat treatment	$\sigma_{H,lim}$ in N/mm^2
through-hardened carbon steels	0,26 R + 350
through-hardened alloy steels	0,42 R + 330
case-hardened alloy steels	1500
nitrided (nitriding steels)	1250
nitrided or induction-hardened (other steels)	1000

2.5 Calculation of tooth bending strength

2.5.1 General

The criterion for tooth bending strength is based on the local tensile stress at the tooth root in the direction of the tooth height.

The tooth root bending stress σ_F is not to exceed the permissible tooth root bending stress σ_{FP} .

2.5.2 Tooth root bending stress σ_F

The tooth root bending stress σ_F is to be determined as follows:

$$\sigma_F = \frac{F_t}{b \cdot m_n} \cdot Y_F \cdot Y_S \cdot Y_\beta \cdot K_A \cdot K_\gamma \cdot K_V \cdot K_{F\beta} \cdot K_{F\alpha}$$

where:

Y_F : Tooth form factor (see [2.5.4])

Y_S : Stress correction factor (see [2.5.5])

Y_β : Helix factor (see [2.5.6])

K_A : Application factor (see [2.3.2])

K_γ : Load sharing factor (see [2.3.3])

K_V : Dynamic factor (see [2.3.4])

$K_{F\beta}$: Face load distribution factor (see [2.3.5])

$K_{F\alpha}$: Transverse load distribution factor (see [2.3.6]).

2.5.3 Permissible tooth root bending stress σ_{FP}

The permissible tooth root bending stress σ_{FP} is to be determined separately for pinion and wheel using the following formula:

$$\sigma_{FP} = \frac{\sigma_{FE} \cdot Y_d \cdot Y_N}{S_F} \cdot (Y_{\delta relT} \cdot Y_{RrelT} \cdot Y_X)$$

where:

σ_{FE} : Endurance limit for tooth root bending stress (see [2.5.7])

Y_d : Design factor (see [2.5.8])

Y_N : Life factor for bending stress (see [2.5.9])

$Y_{\delta relT}$: Relative notch sensitive factor (see [2.5.10])

- Y_{RelT} : Relative surface factor (see [2.5.11])
- Y_X : Size factor (see [2.5.12])
- S_F : Safety factor for tooth root bending stress (see [2.5.13]).

2.5.4 Tooth form factor Y_F

The tooth form factor Y_F takes into account the effect of the tooth form on the nominal bending stress assuming the load applied at the outer point of a single pair tooth contact.

In the case of helical gears, the form factors are to be determined in the normal section, i.e. for the virtual spur gear with the virtual number of teeth z_n .

Y_F is to be determined separately for the pinion and the wheel using the following formula:

$$Y_F = \frac{6 \cdot \frac{h_{Fe}}{m_n} \cdot \cos \alpha_{Fen}}{\left(\frac{s_{Fn}}{m_n}\right)^2 \cdot \cos \alpha_n}$$

where h_{Fe} , α_{Fen} and s_{Fn} are shown in Fig 1.

The parameters required for the calculation of Y_F are to be determined according to Method B of ISO 6336-3.

2.5.5 Stress correction factor Y_S

The stress correction factor Y_S is used to convert the nominal bending stress to local tooth root stress, assuming the load applied at the outer point a single pair tooth contact. It takes into account the influence of:

- the bending moment
- the proximity of the load application to the critical section.

Y_S is to be determined as follows:

$$Y_S = (1,2 + 0,13L) \cdot q_s^{\left(\frac{1}{1,21 + (2,3/L)}\right)}$$

where:

- $L = \frac{s_{Fn}}{h_{Fe}}$
 s_{Fn} and h_{Fe} are taken from [2.5.4]
- the notch parameter q_s as defined in [2.5.10] is assumed to be within the range $1 \leq q_s < 8$.

2.5.6 Helix angle factor Y_β

The helix angle factor Y_β converts the tooth root stress of a virtual spur gear to that of the corresponding helical gear, taking into account the oblique orientation of the lines of mesh contact.

Y_β is to be determined as follows:

- for $\epsilon_\beta \leq 1$: $Y_\beta = 1 - 0,477 \epsilon_\beta \beta$
- for $\epsilon_\beta > 1$: $Y_\beta = 1 - 0,477 \beta$

Where $\beta > 0,52$ rad, the value $\beta = 0,52$ rad is to be substituted for β in the above formulae.

2.5.7 Endurance limit for tooth root bending stress σ_{FE}

The endurance limit for tooth root bending stress σ_{FE} is the local tooth root bending stress which can be permanently endured.

The values to be adopted for σ_{FE} are given in Tab 10 in relation to the type of steel employed, unless otherwise documented according to recognised standards.

Figure 1 : Geometric elements of teeth

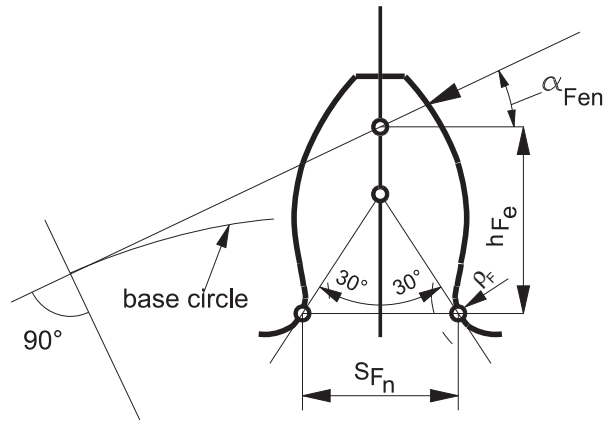

Table 10 : Values of endurance limit for tooth root bending stress σ_{FE}

Type of steel	σ_{FE} , in N/mm ²
Through-hardened carbon steel	0,17 R + 300 (1)
Through-hardened alloy steel	0,22 R + 340 (1)
Surface-hardened by means of flame or induction hardening	0,66 HV + 270
Nitriding steel, surface-hardened by means of gas nitriding	740
Alloy steels, surface-hardened by means of bath or gas nitriding	640 (1)
Case-hardened steels	840 (1)

(1) In case of shot peened tooth root the given value can be increased up to 20% for case hardened steels and up to 10% for through hardened steels.

2.5.8 Design factor Y_d

The design factor Y_d takes into account the influence of load reversing and shrinkfit prestressing on the tooth root strength.

Y_d is to be determined as follows:

$$Y_d = Y_{dr} \cdot Y_{ds}$$

- for gears with occasional part load in reverse direction, such as main wheel in reverse gearboxes: $Y_{dr} = 0,9$
- for idler gears: $Y_{dr} = 0,7$
- otherwise $Y_{dr} = 1$
- for shrunk on pinions and wheel rims:

$$Y_{ds} = 1 - \frac{\sigma_t}{\sigma_{FE}}$$

where:

- σ_t : shrinkage induced tangential stress in way of the tooth root.
- otherwise: $Y_{ds} = 1$

2.5.9 Life factor for bending stress Y_N

The life factor for bending stress Y_N accounts for the higher tooth root bending stress permissible if a limited life (number of cycles) is required.

Y_N assumed equal to Y_{NT} according to method B ISO 6336-3 or assumed to be as follows:

- for gears intended for ahead running: $Y_N = 1$
- for gear intended for astern running only: $Y_N = 1,25$
- for other intermittent running, Y_N will be specially considered by the Society.

2.5.10 Relative notch sensitivity factor $Y_{\delta rel T}$

The relative notch sensitivity factor $Y_{\delta rel T}$ indicates the extent to which the theoretically concentrated stress lies above the fatigue endurance limit.

$Y_{\delta rel T}$ is to be determined as follows:

- for notch parameter values included in the range $1,5 < q_s < 4$: $Y_{\delta rel T} = 1$
- for notch parameters values outside this range, $Y_{\delta rel T}$ will be specially considered by the Society.

The notch parameter q_s is defined as follows:

$$q_s = \frac{s_{Fn}}{2 \cdot \rho_F}$$

where s_{Fn} and ρ_F are taken from [2.5.4].

2.5.11 Relative surface factor $Y_{Rrel T}$

The relative surface factor $Y_{Rrel T}$ takes into account the dependence of the root strength on the surface condition on the tooth root fillet (roughness).

The values to be adopted for $Y_{Rrel T}$ are given in Tab 11 in relation to the type of steel employed. They are valid only when scratches or similar defects deeper than $2 R_{Z(r)}$ are not present.

Table 11 : Values of relative surface factor $Y_{Rrel T}$

Type of steel	$R_{Z(r)} < 1$	$1 \leq R_{Z(r)} \leq 40$
Normalised steels	1,070	$5,3 - 4,2 (R_{Z(r)}+1)^{0,01}$
Case-hardened or through-hardened steels	1,120	$1,675 - 0,53 (R_{Z(r)}+1)^{0,1}$
Nitrided steels	1,025	$4,3 - 3,26 (R_{Z(r)}+1)^{0,005}$

2.5.12 Size factor Y_x

The size factor Y_x takes into account the decrease of the strength with increasing size.

The values to be adopted for Y_x are given in Tab 12 in relation to the type of steel employed and the value of the normal module m_n .

Table 12 : Values of size factor Y_x

Type of steel	Normal module	Value of Y_x
All types of steel	$m_n \leq 5$	1

Type of steel	Normal module	Value of Y_x
Normalised through-hardened	$5 < m_n < 30$	$1,03 - 0,006 m_n$
	$m_n \geq 30$	0,85
Surface-hardened steels	$5 < m_n < 25$	$1,05 - 0,01 m_n$
	$m_n \geq 25$	0,80

2.5.13 Safety factor for tooth root bending stress S_F

The values to be adopted for the safety factor for tooth root bending stress S_F are given in Tab 13.

Table 13 : Values of safety factor for tooth root bending stress S_F

Type of installation		S_F
Main gears (propulsion)	single machinery	1,55
	duplicate machinery	1,4
Auxiliary gears	single machinery	1,4
	duplicate machinery	1,3

3 Design and construction - except tooth load capacity

3.1 Materials

3.1.1 General

- Forged, rolled and cast materials used in the manufacturing of shafts, couplings, pinions and wheels are to comply with the requirements of Part D.
- Materials other than steels will be given special consideration by the Society.

3.1.2 Steels for pinions and wheel rims

- Steels intended for pinions and wheels are to be selected considering their compatibility in service. In particular, for through-hardened pinion / wheel pairs, the hardness of the pinion teeth is to exceed that of the corresponding wheel. For this purpose, the minimum tensile strength of the pinion material is to exceed that of the wheel by at least 15 %.
- The minimum tensile strength of the core is not to be less than:
 - 750 N/mm² for case-hardened teeth
 - 800 N/mm² for induction-hardened or nitrided teeth

3.2 Teeth

3.2.1 Manufacturing accuracy

- The standard of accuracy of teeth of propulsion machinery gearing transmitting a power of 1000 kW and above is to correspond to that of quality class 4 as defined by ISO 1328-1.
- The standard of accuracy of teeth of propulsion machinery gearing transmitting a power lower than 1000 kW is

to correspond to that of quality class 6 as defined by ISO 1328-1.

- c) A lower standard of accuracy (i.e. higher ISO quality classes) may be accepted for auxiliary machinery gearing and for particular cases of propulsion machinery gearing, subject to special consideration.
- d) Mean roughness (peak-to-valley) of shaved or ground teeth is not to exceed 4 μm .
- e) Wheels are to be cut by cutters with a method suitable for the expected type and quality. Whenever necessary, the cutting is to be carried out in a temperature-controlled environment.

3.2.2 Tooth root

Teeth are to be well faired and rounded at the root. The fillet radius at the root of the teeth, within a plane normal to the teeth, is to be not less than 0,25 m_n .

Profile-grinding of gear teeth is to be performed in such a way that no notches are left in the fillet.

3.2.3 Tooth tips and ends

- a) All sharp edges on the tips and ends of gear teeth are to be removed after cutting and finishing of teeth.
- b) Where the ratio b/d exceeds 0,3, the ends of pinion and wheel are to be chamfered to an angle between 45 and 60 degrees. The chamfering depth is to be at least equal to 1,5 m_n .

3.2.4 Surface treatment

- a) The hardened layer on surface-hardened gear teeth is to be uniform and extended over the whole tooth flank and fillet.
- b) Where the pinions and the toothed portions of the wheels are case-hardened and tempered, the teeth flanks are to be ground while the bottom lands of the teeth remain only case-hardened. The superficial hardness of the case-hardened zone is to be at least equal to 56 C Rockwell units.
- c) Where the pinions and the toothed portions of the wheels are nitrided, the hardened layer is to comply with Tab 14.
- d) The use of other processes of superficial hardening of the teeth, such as flame hardening, will be given special consideration, in particular as regards the values to be adopted for $\sigma_{H,lim}$ and σ_{FE} .

Table 14 : Characteristics of the hardened layer for nitrided gears

Type of steel	Minimum thickness of hardened layer (mm) (1)	Minimum hardness (HV)
Nitriding steel	0,6	500 (at 0,25 mm depth)
Other steels	0,3	450 (surface)
(1) Depth of the hardened layer to core hardness. When the grinding of nitrided teeth is performed, the depth of the hardened layer to be taken into account is the depth after grinding.		

3.3 Wheels and pinions

3.3.1 General

Wheel bodies are to be so designed that radial deflexions and distortions under load are prevented, so as to ensure a satisfactory meshing of teeth.

3.3.2 Welding

- a) Where welding is employed for the construction of wheels, the welding procedure is to be submitted to the Society for approval. Welding processes and their qualification are to comply with Part D.
- b) Stress relieving treatment is to be performed after welding.
- c) Examination of the welded joints is to be performed by means of magnetic particle or dye penetrant tests to the satisfaction of the Surveyor. Suitable arrangements are to be made to permit the examination of the internal side of the welded joints.

3.3.3 Shrink-fits

The shrink assembly of:

- rim and wheel body
- wheel body and shaft

is to be designed according to Sec 7.

3.3.4 Bolting

The bolting assembly of:

- rim and wheel body
- wheel body and shaft

is to be designed according to Sec 7.

The nuts are to be suitably locked by means other than welding.

3.4 Shafts and bearings

3.4.1 General

Shafts and their connections, in particular flange couplings and shrink-fits connections, are to comply with the provisions of Sec 7.

3.4.2 Pinion and wheel shafts

The minimum diameter of pinion and gear wheel shafts is not to be less than the value d_s , in mm, given by the following formula:

$$d_s = \left\{ \left[\left(10,2 + \frac{28000}{R_{s,min}} \right) T \right]^2 + \left[\frac{170000}{412 + R_{s,min}} M \right]^2 \right\}^{\frac{1}{6}} \left(\frac{1}{1 - K_d^4} \right)^{\frac{1}{3}}$$

where:

$R_{s,min}$: minimum yield strength of the shaft material, in N/mm²

T : nominal torque transmitted by the shaft, in Nm

M : bending moment on the shaft, in Nm

K_d : coefficient having the following values:

- for solid shafts: $K_d = 0$
- for hollow shafts, K_d is equal to the ratio of the hole diameter to the outer shaft diameter.

Where $K_d \leq 0,3$: $K_d = 0$ may be taken.

Note 1: The values of d_s , T and M refer to the cross-section of the shaft concerned.

Note 2: In correspondence of keyways d_s shall be increased by 10%.

As an alternative to the above given formula, the Society may accept direct strength calculations showing that the equivalent stress represented in a diagram alternate stress/average stress falls below the lines defined by the points having coordinates:

$(R_m, 0)$, $(0; \sigma_{ia}/1, 5)$

and

$(0, 8R_s, 0)$, $(0; 0, 8R_s)$

where σ_{ia} is the pure alternate bending fatigue limit for a survival probability not less than 80%.

3.4.3 Quill shafts

The minimum diameter of quill shafts subject to torque only is not to be less than the value d_{QS} , in mm, given by the following formula:

$$d_{QS} = \left[\left(7,65 + \frac{27000}{R_{s,min}} \right) \cdot \frac{T}{1 - K_d^4} \right]^{\frac{1}{3}}$$

$R_{s,min}$ and K_d being defined in [3.4.2].

3.4.4 Bearings

- a) Thrust bearings and their supports are to be so designed as to avoid detrimental deflexions under load.
- b) Life duration of bearings L_{10h} calculated according to ISO 281-1, is not be less than 40000 hours. Shorter durations may be accepted on the basis of the actual load time distribution, and subject to the agreement of the owner.

3.5 Casings

3.5.1 General

Gear casings are to be of sufficient stiffness such that misalignment, external loads and thermal effects in all service conditions do not adversely affect the overall tooth contact.

3.5.2 Welded casings

- a) Carbon content of steels used for the construction of welded casings is to comply with the provisions of Part D.
- b) The welded joints are to be so arranged that welding and inspection can be performed satisfactorily. They are to be of the full penetration type.
- c) Welded casings are to be stress-relieved after welding.

3.5.3 Openings

Access or inspection openings of sufficient size are to be provided to permit the examination of the teeth and the structure of the wheels.

3.6 Lubrication and clutch control

3.6.1 General

- a) Manufacturers are to take care of the following points :
 - reliable lubrication of gear meshes and bearings is ensured :
 - over the whole speed range, including starting, stopping and, where applicable, manoeuvring
 - for all angles stated in Sec 1, [2.4]
 - in multi-propellers plants not fitted with shaft brakes, provision is to be made to ensure lubrication of gears likely to be affected by windmilling.
- b) Lubrication by means other than oil circulation under pressure will be given special consideration.

3.6.2 Pumps

- a) Gears intended for propulsion or other essential services are to be provided with:
 - 1) one main lubricating pump, capable of maintaining a sufficient lubrication of the gearbox in the whole speed range
 - 2) and one standby pump independently driven of at least the same capacity.
 - 3) an additional standby pump to the one required above, in case the failure of any pump prevents the propulsion from starting.
- b) In the case of:
 - 1) gears having a transmitted power not exceeding 375 kW
 - 2) or multi-engines plants, one of the pumps mentioned in a) may be a spare pump ready to be connected to the reduction gear lubricating oil system, provided disassembling and reassembling operations can be carried out on board in a short time.
- c) The requirements in a) 1), a) 2) and b) 1), b) 2) also apply to clutch control oil supply pumps.
With reference to the requirements in a) 1) and a) 2), in case the failure of any pump prevents the operation of the clutch, an additional stand-by pump is to be fitted.

3.6.3 Filtration

- a) Forced lubrication systems are to be fitted with a device which efficiently filters the oil in the circuit.
- b) When fitted to gears intended for propulsion machinery or machinery driving electric propulsion generators, such filters are to be so arranged that they can be easily

cleaned without stopping the lubrication of the machines.

3.7 Control and monitoring

3.7.1 In addition to those of this item [3.7], the general requirements given in Chapter 3 apply.

In the case of ships with automation notations, the requirements in Part F, Chapter 3 also apply.

3.7.2 Gears are to be provided with the alarms and safeguards listed in Tab 15.

Note 1: Some departures from Tab 15 may be accepted by the Society in the case of ships with a restricted navigation notation.

4 Installation

4.1 General

4.1.1 Manufacturers and shipyards are to take care directly that stiffness of gear seating and alignment conditions of gears are such as not to adversely affect the overall tooth contact and the bearing loads under all operating conditions of the ship.

4.2 Fitting of gears

4.2.1 Means such as stoppers or fitted bolts are to be arranged in the case of gears subject to propeller thrust. However, where the thrust is transmitted by friction and the relevant safety factor is not less than 2, such means may be omitted.

5 Certification, inspection and testing

5.1 General

5.1.1

- a) Inspection and testing of shafts and their connections (flange couplings, hubs, bolts, pins) are to be carried out in accordance with the provisions of Sec 7.
- b) For inspection of welded joints of wheels, refer to [3.3.2].

5.2 Workshop inspection and testing

5.2.1 Testing of materials

Chemical composition and mechanical properties are to be tested in accordance with the applicable requirements of Pt D, Ch 2, Sec 3 for the following items:

- pinions and wheel bodies
- rims
- plates and other elements intended for propulsion gear casings of welded construction.

5.2.2 Testing of pinion and wheel forgings

- a) Mechanical tests of pinions and wheels are to be carried out in accordance with:
 - Pt D, Ch 2, Sec 3, [5.6] for normalised and tempered or quenched and tempered forgings
 - Pt D, Ch 2, Sec 3, [5.7] for surface-hardened forgings.
- b) Non-destructive examination of pinion and wheel forgings is to be performed in accordance with Pt D, Ch 2, Sec 3, [5.8].

5.2.3 Balancing test

Rotating components, in particular gear wheel and pinion shaft assemblies with the coupling part attached, are to undergo a static balancing test.

Where $n^2.d \geq 1,5.10^9$, gear wheel and pinion shaft assemblies are also to undergo a dynamic balancing test.

5.2.4 Verification of cutting accuracy

Examination of the accuracy of tooth cutting is to be performed in the presence of the Surveyor. Records of measurements of errors, tolerances and clearances of teeth are to be submitted at the request of the Surveyor.

5.2.5 Meshing test

- a) A tooth meshing test is to be performed in the presence of the Surveyor. This test is to be carried out at a load sufficient to ensure tooth contact, with the journals located in the bearings according to the normal running conditions. Before the test, the tooth surface is to be coated with a thin layer of suitable coloured compound.
- b) The results of such test are to demonstrate that the tooth contact is adequately distributed on the length of the teeth. Strong contact marks at the end of the teeth are not acceptable.
- c) A permanent record of the tooth contact is to be made for the purpose of subsequent checking of alignment following installation on board.

5.2.6 Hydrostatic tests

- a) Hydraulic or pneumatic clutches are to be hydrostatically tested before assembly to 1,5 times the maximum working pressure of the pumps.
- b) Pressure piping, pumps casings, valves and other fittings are to be hydrostatically tested in accordance with the requirements of Sec 10, [20].

Table 15 : Reduction gears / reversing gears and clutch monitoring

Symbol convention H = High, HH = High High, G = group alarm L = Low, LL = Low low, I = individual alarm X = function is required, R = remote	Monitoring		Automatic control				
			Main Engine			Auxiliary	
	Alarm	Indica- tion	Slow- down	Shut- down	Control	Stand by Start	Stop
Identification of system parameter							
Lubricating oil temperature		local					
Lubricating oil pressure		local					
	L						
Oil tank level		local					
Clutch control oil pressure	L						

SECTION 5

MAIN PROPULSION SHAFTING

1 General

1.1 Application

1.1.1 This Section applies to shafts, couplings, clutches and other shafting components transmitting power for main propulsion.

For shafting components in engines, gears and thrusters, see Sec 2, Sec 4, Sec 5, Sec 6 and Sec 12, respectively; for propellers, see Sec 8.

For vibrations, see Sec 9.

Additional requirements for navigation in ice are given in Pt F, Ch 9, Sec 3.

1.2 Documentation to be submitted

1.2.1 The Manufacturer is to submit to the Society the documents listed in Tab 1 for approval.

Plans of power transmitting parts and shaft liners listed in Tab 1 are to include the relevant material specifications.

2 Design and construction

2.1 Materials

2.1.1 General

The use of other materials or steels having values of tensile strength exceeding the limits given in [2.1.2], [2.1.3] and [2.1.4] will be considered by the Society in each case.

2.1.2 Shaft materials

In general, shafts are to be of forged steel having tensile strength, R_m , between 400 and 800 N/mm².

Where shafts may experience vibratory stresses close (i.e. higher than 80%) to the permissible stresses for transient operation, the materials are to have a specified minimum ultimate tensile strength (R_m) of 500 N/mm². Otherwise, materials having a specified minimum ultimate tensile strength (R_m) of 400 N/mm² may be used.

Table 1 : Documentation to be submitted

No.	Document (drawings, calculations, etc.)
1	Shafting arrangement (1)
2	Thrust shaft
3	Intermediate shafts
4	Propeller shaft
5	Shaft liners, relevant manufacture and welding procedures, if any
6	Couplings and coupling bolts
7	Flexible couplings (2)
8	Stern tube
9	Details of stern tube glands
10	Oil piping diagram for oil lubricated propeller shaft bearings
11	Shaft alignment calculation, see also [3.3]
<p>(1) This drawing is to show the entire shafting, from the main engine coupling flange to the propeller. The location of the thrust block, and the location and number of shafting bearings (type of material and length) are also to be shown.</p> <p>(2) The Manufacturer of the elastic coupling is also to submit the following data:</p> <ul style="list-style-type: none"> • allowable mean transmitted torque (static) for continuous operation • maximum allowable shock torque • maximum allowable speed of rotation • maximum allowable values for radial, axial and angular misalignment <p>In addition, when the torsional vibration calculation of main propulsion system is required (see Sec 9), the following data are also to be submitted:</p> <ul style="list-style-type: none"> • allowable alternating torque amplitude and power loss for continuous operation, as a function of frequency and/or mean transmitted torque • static and dynamic stiffness, as a function of frequency and/or mean transmitted torque • moments of inertia of the primary and secondary halves of the coupling • damping coefficient or damping capability • properties of rubber components • for steel springs of couplings: chemical composition and mechanical properties of steel employed. 	

2.1.3 Couplings, flexible couplings, hydraulic couplings

Non-solid-forged couplings and stiff parts of elastic couplings subjected to torque are to be of forged or cast steel, or nodular cast iron.

Rotating parts of hydraulic couplings may be of grey cast iron, provided that the peripheral speed does not exceed 40m/s.

2.1.4 Coupling bolts

Coupling bolts are to be of forged, rolled or drawn steel.

2.1.5 Shaft liners

Liners are to be of metallic corrosion resistant material complying with the applicable requirements of Part D and with the approved specification, if any; in the case of liners fabricated in welded lengths, the material is to be recognised as suitable for welding.

In general, they are to be manufactured from castings.

For small shafts, the use of liners manufactured from pipes instead of castings may be considered.

Where shafts are protected against contact with seawater not by metal liners but by other protective coatings, the coating procedure is to be approved by the Society.

2.1.6 Sterntubes

Serntubes are to comply with the requirements of Pt B, Ch 9, Sec 2, [6.7].

2.2 Shafts - Scantling

2.2.1 General

For the check of the scantling, the methods given in [2.2.2] and [2.2.3] apply for intermediate shafts and propeller shafts, respectively. As an alternative, the direct stress calculation method as per [2.2.4] may be applied.

Transitions of diameters are to be designed with either a smooth taper or a blending radius. For guidance, a blending radius equal to the change in diameter is recommended.

2.2.2 Intermediate and thrust shafts

The minimum diameter of intermediate and thrust shafts is not to be less than the value d , in mm, given by the following formula:

$$d = F \cdot k \cdot \left[\frac{P}{n \cdot (1 - Q^4)} \cdot \frac{560}{R_m + 160} \right]^{1/3}$$

where:

- Q :
- in the case of solid shafts: $Q = 0$
 - in the case of hollow shafts: $Q =$ ratio of the hole diameter to the outer shaft diameter in the section concerned.

where $Q \leq 0,4$, $Q = 0$ is to be taken.

Hollow shafts whose longitudinal axis does not coincide with the longitudinal hole axis will be specially considered by the Society in each case.

- F :
- 95 for main propulsion systems powered by diesel engines fitted with slip type coupling, by turbines or by electric motors;
 - 100 for main propulsion systems powered by diesel engines fitted with other type of couplings.

k :

Factor whose value is given in Tab 2 depending upon the different design features of the shafts. For shaft design features other than those given in the Table, the value of k will be specially considered by the Society in each case.

n :

Speed of rotation of the shaft, in r.p.m., corresponding to power P

P :

Maximum continuous power of the propulsion machinery for which the classification is requested, in kW.

R_m :

Value of the minimum tensile strength of the shaft material, in N/mm². Whenever the use of a steel having R_m in excess of 800 N/mm² is allowed in accordance with [2.1], the value of R_m to be introduced in the above formula is not to exceed the following:

- for carbon and carbon manganese steels, a minimum specified tensile strength not exceeding 760 N/mm²
- for alloy steels, a minimum specified tensile strength not exceeding 800 N/mm².

Where materials with greater specified or actual tensile strengths than the limitations given above are used, reduced shaft dimensions are not acceptable when derived from the formula in this item [2.2.2].

In cases of stainless steels and in other particular cases, at the discretion of the Society, the value of R_m to be introduced in the above formula will be specially considered.

The scantlings of intermediate shafts inside tubes or sterntubes will be subject to special consideration by the Society. Where intermediate shafts inside sterntubes are water lubricated, the requirements of [2.4.7] are to be applied.

2.2.3 Propeller shafts

For propeller shafts in general a minimum specified tensile strength R_m to be introduced in the following formula not exceeding 600 N/mm² is to be taken for carbon, carbon manganese and alloy steel.

Where materials with greater specified or actual tensile strengths than the limitations given above are used, reduced shaft dimensions are not acceptable when derived from the formula in this item [2.2.3].

The minimum diameter of the propeller shaft is not to be less than the value d_p , in mm, given by the following formula:

$$d_p = 100 \cdot k_p \cdot \left[\frac{P}{n \cdot (1 - Q^4)} \cdot \frac{560}{R_m + 160} \right]^{1/3}$$

where:

- k_p :
- Factor whose value, depending on the different constructional features of shafts, is given below.

The other symbols have the same meaning as in [2.2.2].

In cases of stainless steels and in other particular cases, at the discretion of the Society, the value of R_m to be introduced in the above formula will be specially considered. In general, the diameter of the part of the propeller shaft located forward of the forward sterntube seal may be gradually reduced to the diameter of the intermediate shaft.

The values of factor k_p to be introduced in the above formula are to be taken as follows:

k_p : $k_p = 1,26$, for propeller shafts where:

- the propeller is keyed on to the shaft taper in compliance with the requirements of [2.5.5]

$k_p = 1,22$, for propeller shafts where:

- the propeller is keyless fitted on to the shaft taper by a shrinkage method in compliance with Sec 8, [3.1.2], or the propeller boss is attached to an integral propeller shaft flange in compliance with [2.5.1]
- the sterntube of the propeller shaft is oil lubricated and provided with oil sealing glands approved by the Society or when the sterntube is water lubricated and the propeller shaft is fitted with a continuous liner.

The above values of k_p apply to the portion of propeller shaft between the forward edge of the aftermost shaft bearing and the forward face of the propeller boss or the forward face of the integral propeller shaft flange for the connection to the propeller boss. In no case is the length of this portion of propeller shaft to be less than 2,5 times the rule diameter d_p obtained with the above formula.

The determination of factor k_p for shaft design features other than those given above will be specially considered by the Society in each case.

For the length of the propeller shaft between the forward edge of the aftermost shaft bearing and the forward edge of the forward sterntube seal:

- $k_p = 1,15$ is to be taken in any event.

2.2.4 Direct stress calculation method

Alternative calculation methods may be considered by the Society. Any alternative calculation method is to include all relevant loads on the complete dynamic shafting system under all permissible operating conditions. Consideration is to be given to the dimensions and arrangements of all shaft connections.

Moreover, an alternative calculation method is to take into account design criteria for continuous and transient operating loads (dimensioning for fatigue strength) and for peak operating loads (dimensioning for yield strength). The fatigue strength analysis may be carried out separately according to different criteria corresponding to different load assumptions, for example the following:

- low cycle fatigue criterion (typically lower than 10^4), i.e. the primary cycles represented by zero to full load and back to zero, including reversing torque if applicable
- high cycle fatigue criterion (typically much higher than 10^7), i.e. torsional vibration stresses permitted for continuous operation, reverse bending stresses and operation passing through a barred speed range or any other transient condition.

Table 2 : Values of factor k

For intermediate shafts with					For thrust shafts external to engines	
integral coupling flange and straight sections	shrink fit coupling	keyways, tapered or cylindrical connection	radial hole	longitudinal slot	on both sides of thrust collar	in way of axial bearing, where a roller bearing is used as a thrust bearing
1,00 (1)	1,00 (2)	1,10 (3) (4)	1,10 (5)	1,20 (6)	1,10 (1)	1,10

- (1) Value applicable in the case of fillet radii in accordance with the provisions of [2.5.1].
- (2) k refers to the plain shaft section only. Where shafts may experience vibratory stresses close to the permissible stresses for continuous operation, an increase in diameter to the shrink fit diameter is to be provided, e.g. a diameter increase of 1 to 2 % and a blending radius as described in [2.2.1].
- (3) Keyways are, in general, not to be used in installations with a barred speed range.
- (4) At a distance of not less than 0,2 d from the end of the keyway, the shaft diameter may be reduced to the diameter calculated using k = 1,0. Fillet radii in the transverse section of the bottom of the keyway are to be not less than 0,0125 d, d being the diameter as calculated above using k = 1,0.
- (5) Value applicable in the case of diameter of radial bore d_i , not exceeding 0,3 d, d being as defined in (4). Cases foreseeing intersection between a radial and an eccentric (r_{ec}) axial bore (see figure below) are specially considered by the Society.

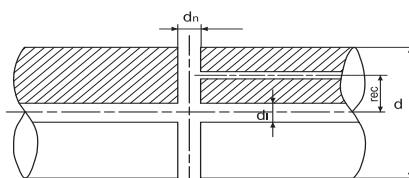

- (6) Subject to limitations: slot length (l)/outside diameter < 0,8, inner diameter (d_i)/outside diameter < 0,8 and slot width (e)/outside diameter > 0,10. The end rounding of the slot is not to be less than $e/2$. An edge rounding is preferably to be avoided as this increases the stress concentration slightly. The k values are valid for 1, 2 and 3 slots, i.e. with slots at, respectively, 360, 180 and 120 degrees apart.

Note 1: Explanation of k and C_k (for C_k see Sec 9, Tab 1)

The factors k (for low cycle fatigue) and C_k (for high cycle fatigue) take into account the influence of:

- the stress concentration factors (scf) relative to the stress concentration for a flange with fillet radius of 0,08 d (geometric stress concentration of approximately 1,45)

$$C_k = \frac{1,45}{scf} \quad \text{and} \quad k = \left(\frac{scf}{1,45} \right)^x$$

where the exponent x considers low cycle notch sensitivity.

- the notch sensitivity. The chosen values are mainly representative for soft steels ($R_m < 600$), while the influence of steep stress gradients in combination with high strength steels may be underestimated.
- the fact that the size factor c_D being a function of diameter only does not purely represent a statistical size influence, but rather a combination of this statistical influence and the notch sensitivity.

The actual values for k and C_k are rounded off.

Note 2: Stress concentration factor of slots

The stress concentration factor (scf) at the end of slots can be determined by means of the following empirical formulae using the symbols in (4)

$$scf = \alpha_{t(hole)} + 0,57 \cdot \frac{(l-e)/d}{\sqrt{\left(1 - \frac{d_i}{d}\right) \cdot \frac{e}{d}}}$$

This formula applies to:

- slots at 120 or 180 or 360 degrees apart.
- slots with semicircular ends. A multi-radii slot end can reduce the local stresses, but this is not included in this empirical formula.
- slots with no edge rounding (except chamfering), as any edge rounding increases the scf slightly.

$\alpha_{t(hole)}$ represents the stress concentration of radial holes (in this context e = hole diameter) and can be determined as :

$$\alpha_{t(hole)} = 2,3 - 3 \cdot \frac{e}{d} + 15 \cdot \left(\frac{e}{d}\right)^2 + 10 \cdot \left(\frac{e}{d}\right)^2 \cdot \left(\frac{d_i}{d}\right)^2$$

or simplified to $\alpha_{t(hole)} = 2,3$.

Note 3: The determination of k factors for shafts other than those provided in this table will be given special consideration by the Society.

2.3 Liners

2.3.1 General

Metal liners or other protective coatings approved by the Society are required where propeller shafts are not made of corrosion-resistant material.

Metal liners are generally to be continuous; however, discontinuous liners, i.e. liners consisting of two or more separate lengths, may be accepted by the Society on a case by case basis, provided that:

- they are fitted in way of all supports
- the shaft portion between liners, likely to come into contact with sea water, is protected with a coating of suitable material with characteristics, fitting method and thickness approved by the Society.

2.3.2 Scantling

The thickness of metal liners fitted on propeller shafts or on intermediate shafts inside stern tubes is to be not less than the value t , in mm, given by the following formula:

$$t = \frac{d + 230}{32}$$

where:

d : Actual diameter of the shaft, in mm.

Between the stern bushes, the above thickness t may be reduced by 25%.

2.4 Stern tube bearings

2.4.1 Oil lubricated aft bearings of antifriction metal

- a) The length of bearings lined with white metal or other antifriction metal and with oil glands of a type approved by the Society is to be not less than twice the rule diameter of the shaft in way of the bearing.
- b) The length of the bearing may be less than that given in (a) above, provided the nominal bearing pressure is not more than 0,8 N/mm², as determined by static bearing reaction calculations taking into account shaft and propeller weight, as exerting solely on the aft bearing, divided by the projected area of the shaft.

However, the minimum bearing length is to be not less than 1,5 times its actual inner diameter.

2.4.2 Oil lubricated aft bearings of synthetic rubber, reinforced resin or plastics material

- a) For bearings of synthetic rubber, reinforced resin or plastics material which are approved by the Society for use as oil lubricated stern bush bearings, the length of the bearing is to be not less than twice the rule diameter of the shaft in way of the bearing.
- b) The length of the bearing may be less than that given in (a) above provided the nominal bearing pressure is not more than 0,6 N/mm², as determined according to [2.4.1] b).

However, the minimum length of the bearing is to be not less than 1,5 times its actual inner diameter.

Where the material has proven satisfactory testing and operating experience, consideration may be given to an increased bearing pressure.

2.4.3 Water lubricated aft bearings of lignum vitae or antifriction metal

Where the bearing comprises staves of wood (known as "lignum vitae") or is lined with antifriction metal, the length of the bearing is to be not less than 4 times the rule diameter of the shaft in way of the bearing.

2.4.4 Water lubricated aft bearings of synthetic materials

- a) Where the bearing is constructed of synthetic materials which are approved by the Society for use as water lubricated stern bush bearings, such as rubber or plastics, the length of the bearing is to be not less than 4 times the rule diameter of the shaft in way of the bearing.
- b) For a bearing design substantiated by experimental data to the satisfaction of the Society, consideration may be given to a bearing length less than 4 times, but in no case less than 2 times, the rule diameter of the shaft in way of the bearing.

2.4.5 Grease lubricated aft bearings

The length of grease lubricated bearings is generally to be not less than 4 times the rule diameter of the shaft in way of the bearing.

2.4.6 Oil or grease lubrication system

- a) For oil lubricated bearings, provision for oil cooling is to be made.

A gravity tank is to be fitted to supply lubricating oil to the stern tube; the tank is to be located above the full load waterline.

Oil sealing glands are to be suitable for the various sea water temperatures which may be encountered in service.

- b) Grease lubricated bearings will be specially considered by the Society.

2.4.7 Water circulation system

For water lubricated bearings, means are to be provided to ensure efficient water circulation. In the case of bearings lined with "lignum vitae" of more than 400 mm in diameter and bearings lined with synthetic materials, means for forced water circulation are to be provided. In the case of bearings of synthetic materials, water flow indicators or pump outlet pressure indicators are to be provided.

The water grooves on the bearings are to be of ample section such as to ensure efficient water circulation and be scarcely affected by wear-down, particularly for bearings of the plastic type.

The shut-off valve or cock controlling the water supply is to be fitted direct to the stuffing box bulkhead or in way of the water inlet to the stern tube, when this is fitted forward of such bulkhead.

2.5 Couplings

2.5.1 Flange couplings

- a) Flange couplings of intermediate and thrust shafts and the flange of the forward coupling of the propeller shaft are to have a thickness not less than 0,2 times the rule

diameter of the solid intermediate shaft and not less than the coupling bolt diameter calculated for a tensile strength equal to that of the corresponding shaft.

Special consideration will be given by the Society to flanges having non-parallel faces, but in no case is the thickness of the flange to be less than the coupling bolt diameter.

The fillet radius at the base of solid forged flanges is to be not less than 0,08 times the actual shaft diameter.

The fillet may be formed of multi-radii in such a way that the stress concentration factor will not be greater than that for a circular fillet with radius 0,08 times the actual shaft diameter.

For non-solid forged flange couplings, the above fillet radius is not to cause a stress in the fillet higher than that caused in the solid forged flange as above.

Filletts are to have a smooth finish and are not to be recessed in way of nuts and bolt heads.

- b) Where the propeller is connected to an integral propeller shaft flange, the thickness of the flange is to be not less than 0,25 times the rule diameter of the aft part of the propeller shaft. The fillet radius at the base of the flange is to be not less than 0,125 times the actual diameter.

The strength of coupling bolts of the propeller boss to the flange is to be equivalent to that of the aft part of the propeller shaft.

- c) Non-solid forged flange couplings and associated keys are to be of a strength equivalent to that of the shaft.

They are to be carefully fitted and shrunk on to the shafts, and the connection is to be such as to reliably resist the vibratory torque and astern pull.

- d) For couplings of intermediate and thrust shafts and for the forward coupling of the propeller shaft having all fitted coupling bolts, the coupling bolt diameter in way of the joining faces of flanges is not to be less than the value d_B , in mm, given by the following formula:

$$d_B = 0,65 \cdot \left[\frac{d^3 \cdot (R_m + 160)}{n_B \cdot D_C \cdot R_{mB}} \right]^{0,5}$$

where:

d : Rule diameter of solid intermediate shaft, in mm, taking into account the ice strengthening requirements of Pt F, Ch 9, Sec 3, where applicable

n_B : Number of fitted coupling bolts

D_C : Pitch circle diameter of coupling bolts, in mm

R_m : Value of the minimum tensile strength of intermediate shaft material taken for calculation of d , in N/mm²

R_{mB} : Tensile strength of the fitted coupling bolts material taken for calculation, in N/mm². The value of the tensile strength of the bolt material taken for calculation R_{mB} is to comply with the following requirements:

- $R_m \leq R_{mB} \leq 1,7 R_m$
- $R_{mB} \leq 1000 \text{ N/mm}^2$

- e) Flange couplings with non-fitted coupling bolts may be accepted on the basis of the calculation of bolt tightening, bolt stress due to tightening, and assembly instructions.

To this end, the torque based on friction between the mating surfaces of flanges is not to be less than 2,8 times the transmitted torque, assuming a friction coefficient for steel on steel of 0,18. In addition, the bolt stress due to tightening in way of the minimum cross-section is not to exceed 0,8 times the minimum yield strength (R_{eH}), or 0,2 proof stress ($R_{p0,2}$), of the bolt material.

Transmitted torque has the following meanings:

- For main propulsion systems powered by diesel engines fitted with slip type or high elasticity couplings or by electric motors: the mean transmitted torque corresponding to the maximum continuous power P and the relevant speed of rotation n , as defined under [2.2.2].
- For main propulsion systems powered by diesel engines fitted with couplings other than those above-mentioned: the mean torque above increased by 20% or by the torque due to torsional vibrations, whichever is the greater.

The value 2,8 above may be reduced to 2,5 in the following cases:

- ships having two or more main propulsion shafts
- when the transmitted torque is obtained, for the whole functioning rotational speed range, as the sum of the nominal torque and the alternate torque due to the torsional vibrations, calculated as required in Sec 9.

2.5.2 Shrunk couplings

Non-integral couplings which are shrunk on the shaft by means of the oil pressure injection method or by other means may be accepted on the basis of the calculation of shrinking and induced stresses, and assembly instructions.

To this end, the force due to friction between the mating surfaces is not to be less than 2,8 times the total force due to the transmitted torque and thrust.

The value 2,8 above may be reduced to 2,5 in the cases specified under item e) of [2.5.1].

The values of 0,14 and 0,18 will be taken for the friction coefficient in the case of shrinking under oil pressure and dry shrink fitting, respectively.

In addition, the equivalent stress due to shrinkage determined by means of the von Mises-Hencky criterion in the points of maximum stress of the coupling is not to exceed 0,8 times the minimum yield strength (R_{eH}), or 0,2% proof stress ($R_{p0,2}$), of the material of the part concerned.

The transmitted torque is that defined under item e) of [2.5.1].

For the determination of the thrust, see Sec 8, [3.1.2].

2.5.3 Other couplings

Types of couplings other than those mentioned in [2.5.1] and [2.5.2] above will be specially considered by the Society.

2.5.4 Flexible couplings

- a) The scantlings of stiff parts of flexible couplings subjected to torque are to be in compliance with the requirements of Article [2].
- b) For flexible components, the limits specified by the Manufacturer relevant to static and dynamic torque, speed of rotation and dissipated power are not to be exceeded.
- c) Where all the engine power is transmitted through one flexible component only (ships with one propulsion engine and one shafting only), the flexible coupling is to be fitted with a torsional limit device or other suitable means to lock the coupling should the flexible component break.

In stiff transmission conditions with the above locking device, a sufficiently wide speed range is to be provided, free from excessive torsional vibrations, such as to enable safe navigation and steering of the ship. As an alternative, a spare flexible element is to be provided on board.

2.5.5 Propeller shaft keys and keyways

- a) Keyways on the propeller shaft cone are to have well rounded corners, with the forward end faired and preferably spooned, so as to minimize notch effects and stress concentrations.

When these constructional features are intended to obtain an extension of the interval between surveys of the propeller shaft in accordance with the relevant provisions of Pt A, Ch 2, Sec 2, [5.5], they are to be in compliance with Fig 1.

Different scantlings may be accepted, provided that at least the same reduction in stress concentration is ensured.

The fillet radius at the bottom of the keyway is to be not less than 1,25% of the actual propeller shaft diameter at the large end of the cone.

The edges of the key are to be rounded.

The distance from the large end of the propeller shaft cone to the forward end of the key is to be not less than

20% of the actual propeller shaft diameter in way of the large end of the cone.

Key securing screws are not to be located within the first one-third of the cone length from its large end; the edges of the holes are to be carefully faired.

- b) The sectional area of the key subject to shear stress is to be not less than the value A, in mm², given by the following formula:

$$A = 0,4 \cdot \frac{d^3}{d_{PM}}$$

where:

d : Rule diameter, in mm, of the intermediate shaft calculated in compliance with the requirements of [2.2.2], assuming:

$$R_m = 400 \text{ N/mm}^2$$

d_{PM} : Actual diameter of propeller shaft at mid-length of the key, in mm.

2.6 Control and monitoring

2.6.1 General

In addition to those given in this item [2.6], the requirements of Chapter 3 apply.

In the case of ships with automation notations, the requirements in Part F, Chapter 3 also apply.

2.6.2 Propeller shaft monitoring

For the assignment of the propeller shaft monitoring system notation, see Pt F, Ch 5, Sec 2.

2.6.3 Indicators

The local indicators for main propulsion shafting to be installed on ships of 500 gross tonnage and upwards without automation notations are given in Tab 3. For monitoring of engines, gears, controllable pitch propellers and thrusters, see Sec 2, Sec 4, Sec 6, Sec 8 and Sec 12, respectively.

The indicators listed in Tab 3 are to be fitted at a normally attended position.

Note 1: Some departures from Tab 3 may be accepted by the Society in the case of ships with a restricted navigation notation

Figure 1 : Details of forward end of propeller shaft keyway

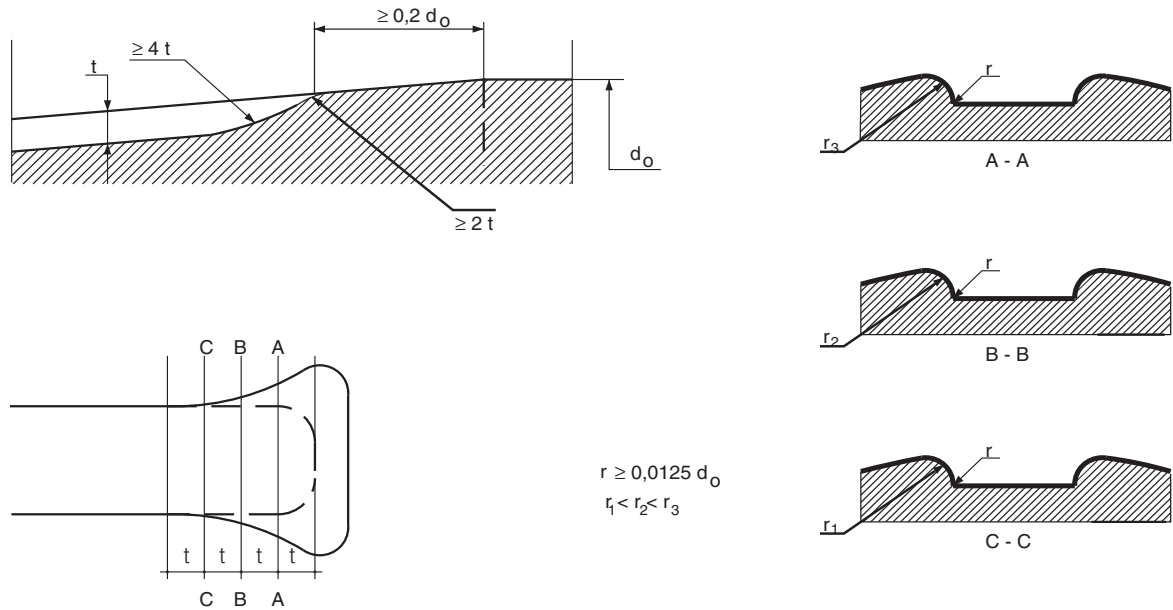

3 Arrangement and installation

3.1 General

3.1.1 The installation is to be carried out according to the instructions of the component Manufacturer or approved documents, when required.

3.1.2 The installation of sterntubes and/or associated non-shrunk bearings is subject to approval of procedures and materials used.

3.1.3 The joints between liner parts are not to be located in way of supports and sealing glands.

Metal liners are to be shrunk on to the shafts by pre-heating or forced on by hydraulic pressure with adequate interference; dowels, screws or other means of securing the liners to the shafts are not acceptable.

3.2 Protection of propeller shaft against corrosion

3.2.1 The propeller shaft surface between the propeller and the sterntube, and in way of propeller nut, is to be suitably protected in order to prevent any entry of sea water, unless the shaft is made of austenitic stainless steel.

3.3 Shaft alignment

3.3.1 In the case of propulsion shafting with turbines, direct coupled engines or bearings with offsets from a reference line, the relevant shaft alignment calculation is to be submitted for approval.

The Society may also require the above calculation in the case of special arrangements.

The alignment of the propulsion machinery and shafting and the spacing and location of the bearings are to be such as to ensure that the loads are compatible with the material used and the limits prescribed by the Manufacturer.

The calculation is to take into account thermal, static and dynamic effects; the results are to include the reaction forces of bearings, bending moments, shear stresses and other parameters (such as gap and sag of each flanged coupling or jacking loads) and instructions for the alignment procedure.

The alignment is to be checked on board by a suitable measurement method.

4 Material tests, workshop inspection and testing, certification

4.1 Material and non-destructive tests, workshop inspections and testing

4.1.1 Material tests

Shafting components are to be tested in accordance with Tab 4 and in compliance with the requirements of Part D.

Magnetic particle or liquid penetrant tests are required for the parts listed in Tab 4 and are to be effected in positions mutually agreed upon by the Manufacturer and the Surveyor, where experience shows defects are most likely to occur.

Table 3 : Shafting of propulsion machinery

Symbol convention H = High, HH = High high, G = group alarm L = Low, LL = Low low, I = individual alarm X = function is required, R = remote	Monitoring		Automatic control				
			Main Engine			Auxiliary	
Identification of system parameter	Alarm	Indica- tion	Slow- down	Shut- down	Control	Stand by Start	Stop
Temperature of each shaft thrust bearing (non applicable for ball or roller bearings)	H		X				
Stern tube bush oil gravity tank level	L						

4.1.2 Hydrostatic tests

Parts of hydraulic couplings, clutches of hydraulic reverse gears and control units, hubs and hydraulic cylinders of controllable pitch propellers, including piping systems and associated fittings, are to be hydrostatically tested to 1,5 times the maximum working pressure.

Stern tubes, when machine-finished, and propeller shaft liners, when machine-finished on the inside and with an over-thickness not exceeding 3 mm on the outside, are to be hydrostatically tested to 0,2 MPa.

4.2 Certification**4.2.1 Testing certification**

Society's certificates (C) (see Pt D, Ch 1, Sec 1, [4.2.1]) are required for material tests of components in items 1 to 5 of Tab 4.

Works' certificates (W) (see Pt D, Ch 1, Sec 1, [4.2.3]) are required for hydrostatic tests of components indicated in [4.1.2] and for material and non-destructive tests of components in items of Tab 4 other than those for which Society's certificates (C) are required.

Table 4 : Material and non-destructive tests

Shafting component	Material tests (Mechanical properties and chemical composition)	Non-destructive tests	
		Magnetic particle or liquid penetrant	Ultrasonic
1) Coupling (separate from shafts)	all	if diameter \geq 250 mm	if diameter \geq 250 mm
2) Propeller shafts	all	if diameter \geq 250 mm	if diameter \geq 250 mm
3) Intermediate shafts	all	if diameter \geq 250 mm	if diameter \geq 250 mm
4) Thrust shafts	all	if diameter \geq 250 mm	if diameter \geq 250 mm
5) Cardan shafts (flanges, crosses, shafts, yokes)	all	if diameter \geq 250 mm	if diameter \geq 250 mm
6) Sterntubes	all	-	-
7) Sterntube bushes and other shaft bearings	all	-	-
8) Propeller shaft liners	all	-	-
9) Coupling bolts or studs	all	-	-
10) Flexible couplings (metallic parts only)	all	-	-
11) Thrust sliding-blocks (frame only)	all	-	-

SECTION 6

PROPELLERS

1 General

1.1 Application

1.1.1 Propulsion propellers

The requirements of this Section apply to propellers of any size and type intended for propulsion. They include fixed and controllable pitch propellers, including those ducted in fixed nozzles.

Additional requirements for navigation in ice are given in Pt F, Ch 9, Sec 3.

1.1.2 Manoeuvring thruster propellers

For manoeuvring thruster propellers see Sec 12.

1.2 Definitions

1.2.1 Solid propeller

A solid propeller is a propeller (including hub and blades) cast in one piece.

1.2.2 Built-up propeller

A built-up propeller is a propeller cast in more than one piece. In general, built up propellers have the blades cast separately and fixed to the hub by a system of bolts and studs.

1.2.3 Controllable pitch propellers

Controllable pitch propellers are built-up propellers which include in the hub a mechanism to rotate the blades in order to have the possibility of controlling the propeller pitch in different service conditions.

1.2.4 Nozzle

A nozzle is a circular structural casing enclosing the propeller.

1.2.5 Ducted propeller

A ducted propeller is a propeller installed in a nozzle.

1.2.6 Skewed propellers

Skewed propellers are propellers whose blades have a skew angle other than 0°.

1.2.7 Highly skewed propellers and very highly skewed propellers

Highly skewed propellers are propellers having blades with skew angle between 25° and 50°. Very highly skewed propellers are propellers having blades with skew angle exceeding 50°.

1.2.8 Leading edge

The leading edge of a propeller blade is the edge of the blade at side entering the water while the propeller rotates (see Fig 1).

1.2.9 Trailing edge

The trailing edge of a propeller blade is the edge of the blade opposite the leading edge (see Fig 1).

Figure 1 : Rake

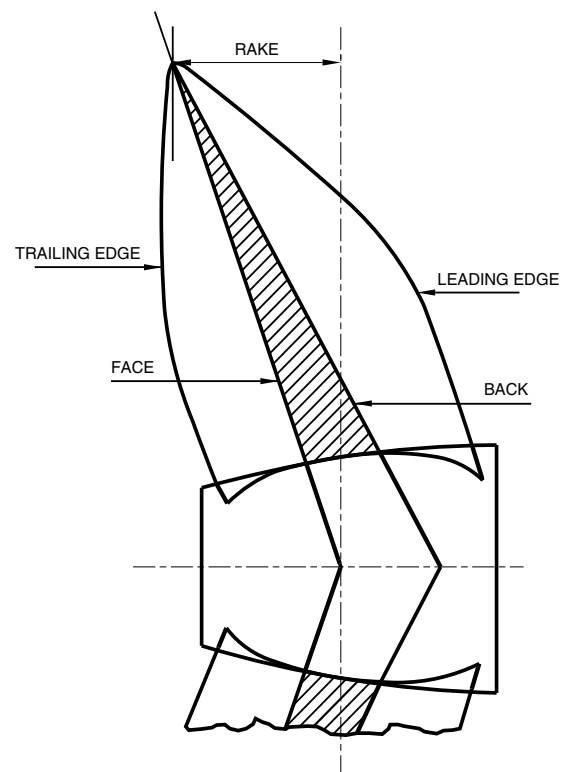

1.2.10 Developed area ratio

Developed area ratio is the ratio of the total blade developed area to the area of the ring included between the propeller diameter and the hub diameter.

1.3 Documentation to be submitted

1.3.1 Solid propellers

The documents listed in Tab 1 are to be submitted for solid propellers intended for propulsion.

All listed plans are to be constructional plans complete with all dimensions and are to contain full indication of types of materials employed.

Table 1 : Documents to be submitted for solid propellers

No.	A/I (1)	ITEM
1	A	Sectional assembly
2	A	Blade and hub details
3	I	Rating (power, rpm, etc.)
4	A	Data and procedures for fitting propeller to the shaft
(1) A = to be submitted for approval in four copies I = to be submitted for information in duplicate		

1.3.2 Built-up and controllable pitch propellers

The documents listed in Tab 2, as applicable, are to be submitted for built-up and controllable pitch propellers intended for propulsion.

Table 2 : Documents to be submitted for built-up and controllable pitch propellers

No.	A/I (1)	ITEM
1	A/I	Same documents requested for solid propellers
2	A	Blade bolts and pre-tensioning procedures
3	I	Pitch corresponding to maximum propeller thrust and to normal service condition
4	A	Pitch control mechanism
5	A	Pitch control hydraulic system
(1) A = to be submitted for approval in four copies I = to be submitted for information in duplicate		

1.3.3 Very highly skewed propellers and propellers of unusual design

For very highly skewed propellers and propellers of unusual design, in addition to the documents listed in Tab 1 and Tab 2, as applicable, a detailed hydrodynamic load and stress analysis is to be submitted (see [2.4.2]).

2 Design and construction**2.1**

2.1.1 Controllable pitch propellers are to be adopted, when driven by diesel engines. If the propellers are electrically driven or rudder propeller type they can be of fixed type, at the condition that the electrical systems can provide 100% of the nominal torque from 100% to 20% of the rpm. To avoid ice accretion and possible blockage of the propeller rotation, suitable devices (bubble system or periodical propeller rotation by means of a turning gear) or procedures (e.g. changing the blade pitch from time to time) are to be provided.

Highly skewed propellers are to be of controllable pitch type.

2.1.2 Materials for studs

In general, steel (preferably nickel-steel) is to be used for manufacturing the studs connecting steel blades to the hub of built-up or controllable pitch propellers, and high tensile

brass or stainless steel is to be used for studs connecting bronze blades.

2.2 Materials**2.2.1 Normally used materials for propeller hubs and blades**

- Tab 3 indicates the minimum tensile strength R_m (in N/mm²), the density δ (in kg/dm³) and the material factor f of normally used materials.
- Common bronze, special types of bronze and cast steel used for the construction of propeller hubs and blades are to have a minimum tensile strength of 400 N/mm².
- Other materials are subject of special consideration by the Society following submission of full material specification.

Table 3 : Normally used materials for propeller blades and hub

Material	R_m	δ	f
Common brass	400	8,3	7,6
Manganese brass (Cu1)	440	8,3	7,6
Nickel-manganese brass (Cu2)	440	8,3	7,9
Aluminium bronze (Cu3 and Cu4)	590	7,6	8,3
Steel	440	7,9	9,0

2.2.2 Materials for studs

In general, steel (preferably nickel-steel) is to be used for manufacturing the studs connecting steel blades to the hub of built-up or controllable pitch propellers, and high tensile brass or stainless steel is to be used for studs connecting bronze blades.

2.3 Solid propellers - Blade thickness**2.3.1**

- The maximum thickness $t_{0,25}$, in mm, of the solid propeller blade at the section at 0,25 radius from the propeller axis is not to be less than that obtained from the following formula:

$$t_{0,25} = 3,2 \left[f \cdot \frac{1,5 \cdot 10^6 \cdot \rho \cdot M_T + 51 \cdot \delta \cdot \left(\frac{D}{100}\right)^3 \cdot B \cdot l \cdot N^2 \cdot h}{l \cdot z \cdot R_m} \right]^{0,5}$$

where:

- f : Material factor as indicated in Tab 3
- ρ : D/H
- H : Mean pitch of propeller, in m. When H is not known, the pitch $H_{0,7}$ at 0,7 radius from the propeller axis, may be used instead of H .
- D : Propeller diameter, in m
- M_T : Continuous transmitted torque, in kN.m; where not indicated, the value given by the following formula may be assumed for M_T :

$$M_T = 9,55 \cdot \left(\frac{P}{N}\right)$$

- P : Maximum continuous power of propulsion machinery, in kW
- N : Rotational speed of the propeller, in rev/min
- δ : Density of blade material, in kg/dm³, as indicated in Tab 3
- B : Expanded area ratio
- h : Rake, in mm
- l : Developed width of blade section at 0,25 radius from propeller axis, in mm
- z : Number of blades
- R_m : Minimum tensile strength of blade material, in N/mm².

- b) The maximum thickness $t_{0,6}$, in mm, of the solid propeller blade at the section at 0,6 radius from the propeller axis is not to be less than that obtained from the following formula:

$$t_{0,6} = 1,9 \left[f \frac{1,5 \cdot 10^6 \cdot \rho_{0,6} \cdot M_T + 18,4 \cdot \delta \cdot \left(\frac{D}{100}\right)^3 \cdot B \cdot l \cdot N^2 \cdot h}{l_{0,6} \cdot z \cdot R_m} \right]^{0,5}$$

where:

- $\rho_{0,6}$: D/H_{0,6}
- H_{0,6} : Pitch at 0,6 radius from the propeller axis, in m
- l_{0,6} : Developed width of blade section at 0,6 radius from propeller axis, in mm.

- c) The radius at the blade root is to be at least $\frac{3}{4}$ of the required minimum thickness $t_{0,25}$. As an alternative, constant stress fillets may also be considered. When measuring the thickness of the blade, the increased thickness due to the radius of the fillet at the root of the blade is not to be taken into account. If the propeller hub extends over 0,25 radius, the thickness calculated by the formula in a) is to be compared with the thickness obtained by linear interpolation of the actual blade thickness up to 0,25 radius.
- d) As an alternative to the above formulae, a detailed hydrodynamic load and stress analysis carried out by the propeller designer may be considered by the Society, on a case by case basis. The safety factor to be used in this analysis is not to be less than 8 with respect to the ultimate tensile strength of the propeller material R_m.

2.4 Built-up propellers and controllable pitch propellers

2.4.1 Blade thickness

- a) The maximum thickness $t_{0,35}$, in mm, of the blade at the section at 0,35 radius from the propeller axis is not to be less than that obtained from the following formula:

$$t_{0,35} = 2,7 \left[f \frac{1,5 \cdot 10^6 \cdot \rho_{0,7} \cdot M_T + 41 \cdot \delta \cdot \left(\frac{D}{100}\right)^3 \cdot B \cdot l_{0,35} \cdot N^2 \cdot h}{l_{0,35} \cdot z \cdot R_m} \right]^{0,5}$$

where:

- $\rho_{0,7}$: D/H_{0,7}
- H_{0,7} : Pitch at 0,7 radius from the propeller axis, in m. The pitch to be used in the formula is the actual pitch of the propeller when the propeller develops the maximum thrust.
- l_{0,35} : Developed width of blade section at 0,35 radius from propeller axis, in mm.

- b) The maximum thickness $t_{0,6}$, in mm, of the propeller blade at the section at 0,6 radius from the propeller axis is not to be less than that obtained from the formula in [2.2.1], item b, using the value of l_{0,35} in lieu of l.
- c) The radius at the blade root is to be at least $\frac{3}{4}$ of the required minimum thickness $t_{0,35}$. As an alternative, constant stress fillets may also be considered. When measuring the thickness of the blade, the increased thickness due to the radius of the fillet at the root of the blade is not to be taken into account.
- d) As an alternative to the above formulae, a detailed hydrodynamic load and stress analysis carried out by the propeller designer may be considered by the Society, on a case by case basis. The safety factor to be used in this analysis is not to be less than 8 with respect to the ultimate tensile strength of the propeller blade material R_m.

2.4.2 Flanges for connection of blades to hubs

- a) The diameter D_F, in mm, of the flange for connection to the propeller hub is not to be less than that obtained from the following formula:

$$D_F = D_C + 1,8d_{PR}$$

where:

- D_C : Stud pitch circle diameter, in mm
- d_{PR} : Diameter of studs.

- b) The thickness of the flange is not to be less than 1/10 of the diameter D_F.

2.4.3 Connecting studs

- a) The diameter d_{PR}, in mm, at the bottom of the thread of the studs is not to be less than that obtained from the following formula:

$$d_{PR} = \left(\frac{4,6 \cdot 10^7 \cdot \rho_{0,7} \cdot M_T + 0,88 \cdot \delta \cdot \left(\frac{D}{10}\right)^3 \cdot B \cdot l_{0,35} \cdot N^2 \cdot h_1}{n_{PR} \cdot z \cdot D_C \cdot R_{m,PR}} \right)^{0,5}$$

where:

- h₁ : h + 1,125 D_C
- n_{PR} : Total number of studs in each blade,

$R_{m,PR}$: Minimum tensile strength of stud material, in N/mm².

- b) The studs are to be tightened in a controlled manner such that the tension on the studs is approximately 60-70 % of their yield strength.
- c) The shank of studs may be designed with a minimum diameter equal to 0,9 times the root diameter of the thread.
- d) The studs are to be properly secured against unintentional loosening.

2.5 Skewed propellers

2.5.1 Skewed propellers

The thickness of skewed propeller blades may be obtained by the formulae in [2.2] and [2.3.1], as applicable, provided the skew angle is less than 25°.

2.5.2 Highly skewed propellers

- a) For solid and controllable pitch propellers having skew angles between 25° and 50°, the blade thickness, in mm, is not to be less than that obtained from the following formulae:

- 1) For solid propellers

$$t_{s-0,25} = t_{0,25} \cdot (0,92 + 0,0032 \vartheta)$$

- 2) For built-up and controllable pitch propellers

$$t_{s-0,35} = t_{0,35} \cdot (0,9 + 0,004 \vartheta)$$

- 3) For all propellers

$$t_{s-0,6} = t_{0,6} \cdot (0,74 + 0,0129 \vartheta - 0,0001 \vartheta^2)$$

$$t_{s-0,9} = t_{0,6} \cdot (0,35 + 0,0015 \vartheta)$$

where:

- $t_{s-0,25}$: Maximum thickness, in mm, of skewed propeller blade at the section at 0,25 radius from the propeller axis
- $t_{0,25}$: Maximum thickness, in mm, of normal shape propeller blade at the section at 0,25 radius from the propeller axis, obtained by the formula in [2.2.1]
- $t_{s-0,35}$: Maximum thickness, in mm, of skewed propeller blade at the section at 0,35 radius from the propeller axis
- $t_{0,35}$: Maximum thickness, in mm, of normal shape propeller blade at the section at 0,35 radius from the propeller axis, obtained by the formula in [2.3.1]
- $t_{s-0,6}$: Maximum thickness, in mm, of skewed propeller blade at the section at 0,6 radius from the propeller axis
- $t_{0,6}$: Maximum thickness, in mm, of normal shape propeller blade at the section at 0,6 radius from the propeller axis, obtained by the formula in [2.2.1]
- $t_{s-0,9}$: Maximum thickness, in mm, of skewed propeller blade at the section at 0,9 radius from the propeller axis

ϑ : Skew angle.

- b) As an alternative, highly skewed propellers may be accepted on the basis of a stress analysis, as stated in [2.4.3] for very highly skewed propellers.

2.5.3 Very highly skewed propellers

For very highly skewed propellers, the blade thickness is to be obtained by a stress analysis according to a calculation criteria accepted by the Society. The safety factor to be used in this direct analysis is not to be less than 9 with respect to the ultimate tensile strength of the propeller blade material, R_m .

2.6 Ducted propellers

2.6.1 The minimum blade thickness of propellers with wide tip blades running in nozzles is not to be less than the values obtained by the applicable formula in [2.2] or [2.3.1], increased by 10%.

2.7 Features

2.7.1 Blades and hubs

- a) All parts of propellers are to be free of defects and are to be built and installed with clearances and tolerances in accordance with sound marine practice.
- b) Particular care is to be taken with the surface finish of the blades.

2.7.2 Controllable pitch propellers pitch control system

- a) The general requirements given in Sec 10, [14] apply.
- b) Separate oil systems intended for the control of controllable pitch propellers are to include at least two power pumps, of such a capacity as to maintain normal control with any one pump out of action.
- c) In the case of propulsion plants comprising:
 - more than one shaft line with the propellers fitted with their own control system,
 - or one engine with an output not exceeding 375 kW,
 one of the pumps mentioned in b) may be a spare pump ready to be connected to the oil control system, provided disassembling and reassembling operations can be carried out on board in a short time.
- d) However, when the propulsion plant comprises one or more engines, each with an output not exceeding 375 kW, the standby or spare pump may be omitted for the controllable pitch propellers provided that they are so designed as to be fixed mechanically in the "forward" position and that the capacity of the starting means ensures the numbers of starts required in such conditions.
- e) Pitch control systems are to be provided with an engine room indicator showing the actual setting of the blades. Further blade position indicators are to be mounted on the bridge and in the engine control room, if any.
- f) Suitable devices are to be fitted to ensure that an alteration of the blade setting cannot overload the propulsion plant or cause it to stall.

- g) Steps are to be taken to ensure that, in the event of failure of the control system, the setting of the blades
- does not change, or
 - assumes a final position slowly enough to allow the emergency control system to be put into operation.
- h) Controllable pitch propeller systems are to be equipped with means of emergency control enabling the controllable pitch propeller to operate should the remote control system fail. This requirement may be complied with by means of a device which locks the propeller blades in the "ahead" setting.
- i) Tab 4 indicates the monitoring requirements to be displayed at the control console. In addition, the general requirements given in Chapter 3 apply. In the case of ships with automation notations, the requirements in Part F, Chapter 3 also apply.

3 Arrangement and installation

3.1 Fitting of propeller on the propeller shaft

3.1.1 General

- a) Screw propeller hubs are to be properly adjusted and fitted on the propeller shaft cone.
- b) The forward end of the hole in the hub is to have the edge rounded to a radius of approximately 6 mm.
- c) In order to prevent any entry of sea water under the liner and onto the end of the propeller shaft, the arrangement of Fig 2 is generally to be adopted for assembling the liner and propeller boss.
- d) The external stuffing gland is to be provided with a sea-water resistant rubber ring preferably without joints. The clearance between the liner and the internal air space of the boss is to be as small as possible. The internal air space is to be filled with an appropriate protective material which is insoluble in sea water and non-corrodible or fitted with a rubber ring.
- e) All free spaces between the propeller shaft cone, propeller boss, nut and propeller cap are to be filled with a material which is insoluble in sea water and non-corrodible. Arrangements are to be made to allow any air present in these spaces to withdraw at the moment of filling. It is recommended that these spaces be tested under a pressure at least equal to that corresponding to the immersion of the propeller in order to check the tightness obtained after filling.
- f) For propeller keys and key area, see Sec 7, [2.5.5].

3.1.2 Shrinkage of keyless propellers

In the case of keyless shrinking of propellers, the following requirements apply:

- a) The meaning of the symbols used in the subparagraphs below is as follows:
- A : 100% theoretical contact area between propeller boss and shaft, as read from plans and disregarding oil grooves, in mm²
- d_{PM} : Diameter of propeller shaft at the mid-point of the taper in the axial direction, in mm

- d_H : Mean outer diameter of propeller hub at the axial position corresponding to d_{PM} , in mm
- K : $K = d_H/d_{PM}$
- F : Tangential force at interface, in N
- M_T : Continuous torque transmitted; in N.m, where not indicated, M_T may be assumed as indicated in [2.2.1]
- C :
 - $C = 1$ for turbines, geared diesel engines, electrical drives and direct-drive reciprocating internal combustion engines with a hydraulic, electromagnetic or high elasticity coupling,
 - $C = 1,2$ for diesel engines having couplings other than those specified above.

The Society reserves the right to increase the value of C if the shrinkage needs to absorb an extremely high pulsating torque,
- T : Temperature of hub and propeller shaft material, in °C, assumed for calculation of pull-up length and push-up load
- V : Ship speed at P power, in knots
- S : Continuous thrust developed for free running ship, in N
- s_F : Safety factor against friction slip at 35°C
- θ : Half taper of propeller shaft (for instance: taper = 1/15, $\theta = 1/30$)
- μ : Coefficient of friction between mating surfaces
- p_{35} : Surface pressure between mating surfaces, in N/mm², at 35°C
- p_T : Surface pressure, in N/mm², between mating surfaces at temperature T
- p_0 : Surface pressure between mating surfaces, in N/mm², at 0°C
- p_{MAX} : Maximum permissible surface pressure, in N/mm², at 0°C
- d_{35} : Push-up length, in mm, at 35°C
- d_T : Push-up length, in mm, at temperature T
- d_{MAX} : Maximum permissible pull-up length, in mm, at 0°C
- W_T : Push-up load, in N, at temperature T
- σ_{ID} : Equivalent uni-axial stress in the boss according to the von Mises-Hencky criterion, in N/mm²
- α_P : Coefficient of linear expansion of shaft material, in mm/(mm°C)
- α_M : Coefficient of linear expansion of boss material, in mm/(mm°C)
- E_P : Value of the modulus of elasticity of shaft material, in N/mm²
- E_M : Value of the modulus of elasticity of boss material, in N/mm²
- ν_P : Poisson's ratio for shaft material
- ν_M : Poisson's ratio for boss material

$R_{S,MIN}$: Value of the minimum yield strength (R_{eH}), or 0,2% proof stress ($R_{p0,2}$), of propeller boss material, in N/mm².

For other symbols not defined above, see [2.2].

- b) The manufacturer is to submit together with the required constructional plans specifications containing all elements necessary for verifying the shrinkage. Tests and checks deemed necessary for verifying the characteristics and integrity of the propeller material are also to be specified.
- c) The formulae and other provisions below do not apply to propellers where a sleeve is introduced between shaft and boss or in the case of hollow propeller shafts. In such cases, a direct shrinkage calculation is to be submitted to the Society.
- d) The taper of the propeller shaft cone is not to exceed 1/15.
- e) Prior to final pull-up, the contact area between the mating surfaces is to be checked and is not to be less than 70% of the theoretical contact area (100%). Non-contact bands extending circumferentially around the boss or over the full length of the boss are not acceptable.
- f) After final push-up, the propeller is to be secured by a nut on the propeller shaft. The nut is to be secured to the shaft.
- g) The safety factor s_F against friction slip at 35°C is not to be less than 2,8, under the combined action of torque and propeller thrust, based on the maximum continuous power P for which classification is requested at the corresponding speed of rotation N of the propeller, plus pulsating torque due to torsionals.
- h) For the oil injection method, the coefficient of friction μ is to be 0,13 in the case of bosses made of copper-based alloy and steel. For other methods, the coefficient of friction will be considered in each case by the Society.
- i) The maximum equivalent uni-axial stress in the boss at 0°C, based on the von Mises-Hencky criterion, is not to exceed 70% of the minimum yield strength (R_{eH}), or 0,2% proof stress ($R_{p0,2}$), of the propeller material, based on the test piece value. For cast iron, the value of the above stress is not to exceed 30% of the nominal tensile strength.
- j) For the formulae given below, the material properties indicated in the following items are to be assumed:
- Modulus of elasticity, in N/mm²:

Cast and forged steel:	$E = 206000$
Cast iron:	$E = 98000$
Type Cu1 and Cu2 brass:	$E = 108000$
Type Cu3 and Cu4 brass:	$E = 118000$
 - Poisson's ratio:

Cast and forged steel:	$\nu = 0,29$
Cast iron:	$\nu = 0,26$
All copper based alloys:	$\nu = 0,33$
 - Coefficient of linear expansion in mm/(mm°C)

Cast and forged steel and cast iron:	$\alpha = 12,0 \cdot 10^{-6}$
All copper based alloys:	$\alpha = 17,5 \cdot 10^{-6}$

- k) For shrinkage calculation the formulae in the following items, which are valid for the ahead condition, are to be applied. They will also provide a sufficient margin of safety in the astern condition.

- Minimum required surface pressure at 35°C:

$$p_{35} = \frac{s_F S}{AB} \cdot \left[-s_F \theta + \left(\mu^2 + B \cdot \frac{F^2}{S^2} \right)^{0,5} \right]$$

where:

$$B = \mu^2 - s_F^2 \theta^2$$

- Corresponding minimum pull-up length at 35°C:

$$d_{35} = \frac{p_{35} d_{PM}}{2\theta} \cdot \left[\frac{1}{E_M} \cdot \left(\frac{K^2 + 1}{K^2 - 1} + \nu_M \right) + \frac{1 - \nu_P}{E_P} \right]$$

- Minimum pull-up length at temperature T ($T < 35^\circ\text{C}$):

$$d_T = d_{35} + \frac{d_{PM}}{2\theta} \cdot (\alpha_M - \alpha_P) \cdot (35 - T)$$

- Corresponding minimum surface pressure at temperature T:

$$p_T = p_{35} \cdot \frac{d_T}{d_{35}}$$

- Minimum push-up load temperature T:

$$W_T = A p_T \cdot (\mu + \theta)$$

- Maximum permissible surface pressure at 0°C:

$$p_{MAX} = \frac{0,7 R_{S,MIN} \cdot (K^2 - 1)}{(3K^4 + 1)^{0,5}}$$

- Corresponding maximum permissible pull-up length at 0°C:

$$d_{MAX} = d_{35} \cdot \frac{p_{MAX}}{p_{35}}$$

- Tangential force at interface:

$$F = \frac{2000 C M_T}{d_{PM}}$$

- Continuous thrust developed for free running ship; if the actual value is not given, the value, in N, calculated by one of the following formulae may be considered:

$$S = 1760 \cdot \frac{P}{V}$$

$$S = 57,3 \cdot 10^3 \cdot \frac{P}{H \cdot N}$$

3.1.3 Circulating currents

Means are to be provided to prevent circulating electric currents from developing between the propeller and the hull. A description of the type of protection provided and its maintenance is to be kept on board.

4 Testing and certification

4.1 Material tests

4.1.1 Solid propellers

Material used for the construction of solid propellers is to be tested in accordance with the requirements of Part D of the Rules in the presence of the Surveyor.

4.1.2 Built-up propellers and controllable pitch propellers

In addition to the requirement in [4.1.1], materials for studs and for all other parts of the mechanism transmitting torque are to be tested in the presence of the Surveyor.

4.2 Testing and inspection

4.2.1 Inspection of finished propeller

Finished propellers are to be inspected at the manufacturer's plant by the Surveyor. At least the following checks are to be carried out:

- visual examination of the entire surface of the propeller blades
- conformity to approved plans of blade profile
- liquid penetrant examination of suspected and critical parts of the propeller blade, to the satisfaction of the Surveyor.

4.2.2 Controllable pitch propellers

The complete hydraulic system for the control of the controllable pitch propeller mechanism is to be hydrotested at a pressure equal to 1,5 times the design pressure. The proper

operation of the safety valve is to be tested in the presence of the Surveyor.

4.2.3 Balancing

Finished propellers are to be statically balanced. For built-up and controllable pitch propellers, the required static balancing of the complete propeller may be replaced by an individual check of blade weight and gravity centre position.

In addition, for propellers running above 500 rpm, dynamic balancing:

- is required, for cast copper alloy propellers
- may be required, for cast steel propellers.

4.3 Certification

4.3.1 Certification of propellers

Propellers having the characteristics indicated in [1.1.1] are to be individually tested and certified by the Society.

4.3.2 Mass produced propellers

Mass produced propellers may be accepted within the framework of the type approval program of the Society.

Table 4 : Controllable pitch propeller monitoring

Symbol convention H = High, HH = High high, G = group alarm L = Low, LL = Low low, I = individual alarm X = function is required, R = remote	Monitoring		Automatic control				
			Main Engine			Auxiliary	
	Alarm	Indication	Slow-down	Shut-down	Control	Stand by Start	Stop
Identification of system parameter							
Pump pressure	L						
Oil tank level	L						

Figure 2 : Example of sealing arrangement

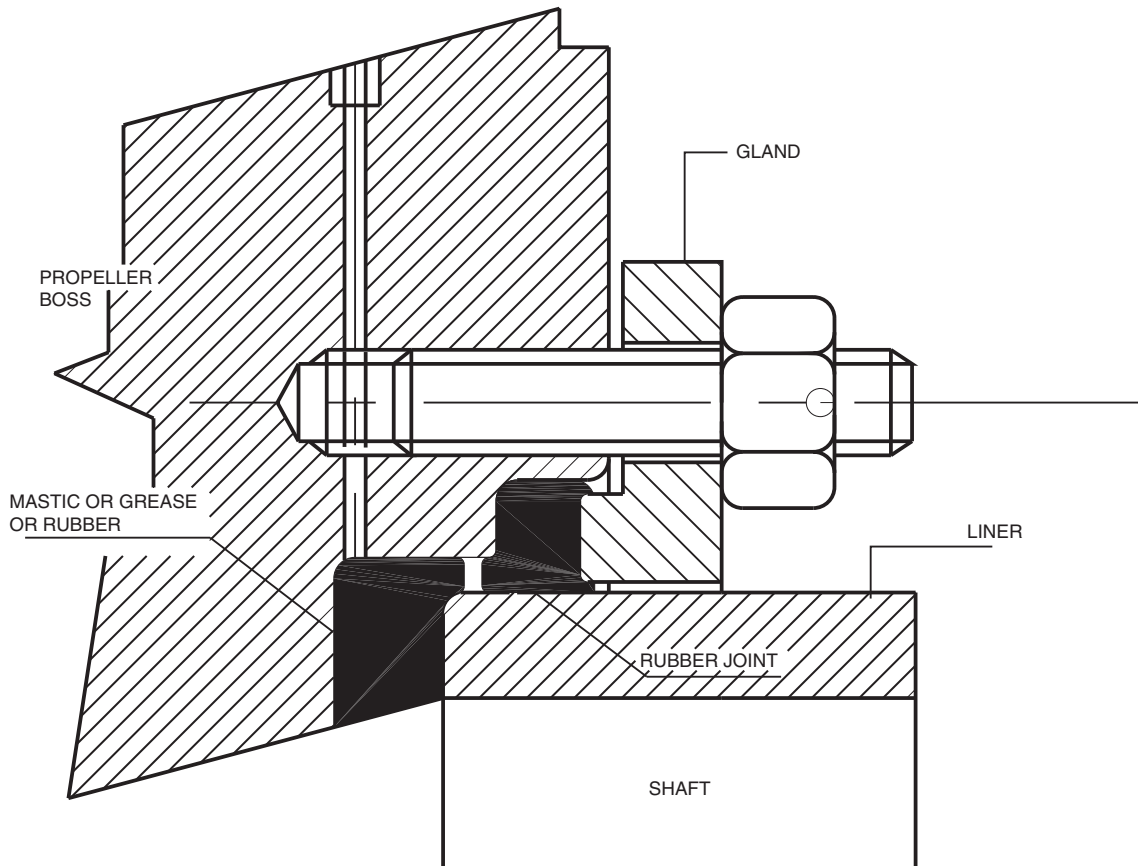

SECTION 7

SHAFT VIBRATIONS

1 General

1.1 Application

1.1.1 The requirements of this Section apply to the shafting of the following installations:

- propulsion systems with prime movers developing 220 kW or more
- other systems with internal combustion engines developing 110 kW or more and driving auxiliary machinery intended for essential services.

1.1.2 Exemptions

The requirements of this Section may be waived at the Society's discretion in cases where satisfactory service operation of similar installations is demonstrated or in the case of ships classed for restricted navigation.

1.2 Submission of documentation

1.2.1 As the analysis of the vibration behaviour of systems is part of their design, the relevant documentation, as listed in [3.2] is to be promptly submitted for approval.

2 Design of systems in respect of vibrations

2.1 Principle

2.1.1 General

- Special consideration shall be given to the design, construction and installation of propulsion machinery systems so that any mode of their vibrations shall not cause undue stresses in these systems in the normal operating ranges.
- Calculations are to be carried out for all the configurations of the system likely to have any influence on the torsional, bending or axial vibrations.
- Where torsional and axial vibrations may be coupled (e.g. due to helical gears), the effect of such vibrations is to be investigated.

2.1.2 Vibration levels

Systems are to have torsional, bending and axial vibrations both in continuous and in transient running acceptable to the Manufacturers, and in accordance with the requirements of this section.

Where vibrations are found to exceed the limits stated in this Section, the designer or the builder of the plant is to propose corrective actions, such as:

- operating restrictions, provided that the owner is informed, or
- modification of the plant.

2.1.3 Condition of components

Systems are to be designed considering essential components in a non-ideal condition. In particular, the following conditions are to be considered:

- propulsion engine: cylinder malfunction,
- flexible coupling: possible variation of the stiffness or damping characteristics due to heating or ageing,
- vibration damper: possible variation of the damping coefficient.

2.2 Modifications of existing plants

2.2.1 Where substantial modifications of existing plants, such as:

- change of the running speed or power of the engine,
- replacement of an essential component of the system (propeller, flexible coupling, damper) by one of different characteristics, or
- connection of a new component,

are carried out, new vibration analysis is to be submitted for approval.

3 Torsional vibrations

3.1 General

3.1.1 The torsional vibration torques (or stresses) calculated in the various components of the installation are additional to those resulting from the mean power transmitted by such components. Where the scantling formulae given in Sec 7 and App 1 are applied, the vibratory torques are not to be taken into account unless otherwise stated.

3.2 Documentation to be submitted

3.2.1 Calculations

Torsional vibration calculations are to be submitted for the various configurations of the plants, showing:

- the equivalent dynamic system used for the modelling of the plant, with indication of:
 - inertia and stiffness values for all the components of the system
 - diameter and material properties of the shafts
- the natural frequencies
- the values of the vibratory torques or stresses in the components of the system for the most significant critical speeds and their analysis in respect of the Rules and other acceptance criteria
- the possible restrictions of operation of the plant.

3.2.2 Particulars to be submitted

The following particulars are to be submitted with the torsional vibration calculations:

- a) for multi-engine installations or installations with power take-off systems:
 - description of the operating configurations
 - load sharing law between the various components for each configuration
 - b) for installations with controllable pitch propellers, the power/rotational speed values resulting from the combinator operation
 - c) for prime movers, the service speed range and the minimum speed at no load
 - d) for internal combustion engines:
 - manufacturer and type
 - nominal output and rotational speed
 - mean indicated pressure
 - number of cylinders
 - "V" angle
 - firing angles
 - bore and stroke
 - excitation data, such as the polynomial law of harmonic components of excitations
 - nominal alternating torsional stress considered for crankpin and journal
- Note 1: The nominal alternating torsional stress is part of the basic data to be considered for the assessment of the crankshaft. It is defined in App 1.
- e) for reduction or step-up gears, the speed ratio for each step
 - f) for flexible couplings, the data required in Note 2 of Sec 7, Tab 1
 - g) for torsional vibration dampers:
 - the manufacturer and type
 - the permissible heat dissipation
 - the damping coefficient
 - the inertial and stiffness properties, as applicable
 - h) for propellers:
 - the number of blades
 - the excitation and damping data, if available
 - i) for electric motors, generators and pumps, the drawing of the rotating parts, with their mass moment of inertia and main dimensions.

3.3 Definitions, symbols and units

3.3.1 Definitions

- a) Torsional vibration stresses referred to in this Article are the stresses resulting from the alternating torque corresponding to the synthesis of the harmonic orders concerned.
- b) The misfiring condition of an engine is the malfunction of one cylinder due to the absence of fuel injection (which results in a pure compression or expansion in the cylinder).

3.3.2 Symbols, units

The main symbols used in this Article are defined as follows:

- | | |
|-------------|---|
| τ | : Torsional vibration stress, as defined in [3.3.1], in N/mm ² |
| τ_1 | : Permissible stress due to torsional vibrations for continuous operation, in N/mm ² |
| τ_2 | : Permissible stress due to torsional vibrations for transient running, in N/mm ² |
| R_m | : Tensile strength of the shaft material, in N/mm ² |
| C_R | : Material factor, equal to:
$\frac{R + 160}{18}$ |
| d | : Minimum diameter of the shaft, in mm |
| C_D | : Size factor of the shaft, equal to:
$0,35 + 0,93 d^{0,2}$ |
| N | : Speed of the shaft for which the check is carried out, in rev/min |
| N_n | : Nominal speed of the shaft, in rev/min |
| N_c | : Critical speed, in rev/min |
| λ | : Speed ratio, equal to N/N_n |
| C_λ | : Speed ratio factor, equal to: <ul style="list-style-type: none"> • $3 - 2 \lambda^2$ for $\lambda < 0,9$ • $1,38$ for $0,9 \leq \lambda \leq 1,05$ |
| C_k | : Factor depending on the shaft design features given in Tab 1. |

3.4 Calculation principles

3.4.1 Method

- a) Torsional vibration calculations are to be carried out using a recognised method.
- b) Where the calculation method does not include harmonic synthesis, attention is to be paid to the possible superimposition of two or more harmonic orders of different vibration modes which may be present in some restricted ranges.

Table 1 : Values of C_k factors

Intermediate shafts						Thrust shafts external to engines		Propeller shafts	
with integral coupling flanges and straight sections	with shrink-fit couplings	with keyways, tapered connection	with keyways, cylindrical connection	with radial holes	with longitudinal slots	on both sides of thrust collar	in way of axial bearing where a roller bearing is used as a thrust bearing	for which (5) $k = 1,22$ or $k = 1,26$	for which (5) $k = 1,15$
1,00 (1)	1,00 (2)	0,60 (3)	0,45 (3)	0,50	0,30 (4)	0,85	0,85	0,55	0,80
<p>(1) Value applicable in the case of fillet radii in accordance with the provisions of Sec 7, [2.5.1].</p> <p>(2) C_k refers to the plain shaft section only. Where shafts may experience vibratory stresses close to the permissible stresses for continuous operation, an increase in diameter to the shrink fit diameter is to be provided, e.g. a diameter increase of 1 to 2 % and a blending radius as described in Sec 7, [2.2.1]</p> <p>(3) Keyways are, in general, not to be used in installations with a barred speed range.</p> <p>(4) $C_k = 0,3$ is a safe approximation within the limitations in (6) of Sec 7, Tab 2. If the slot dimensions are outside of the above limitations, or if the use of another C_k is desired, the actual stress concentration factor (scf) is to be documented or determined from the criteria of accumulate fatigue. In which case: $C_k = 1,45/scf$ Note that the scf is defined as the ratio between the maximum local principal stress and $3^{0.5}$ times the nominal torsional stress (determined for the bored shaft without slots).</p> <p>(5) k is defined in Sec 7.</p> <p>Note 1: For explanation of c_k and stress concentration factor of slots, see Sec 7, Tab 2.</p> <p>Note 2: The determination of C_k factors for shafts other than those given in this table will be given special consideration by the Society.</p>									

3.4.2 Scope of the calculations

- Torsional vibration calculations are to be carried out considering:
 - normal firing of all cylinders, and
 - misfiring of one cylinder.
- Where the torsional dynamic stiffness of the coupling depends on the transmitted torque, two calculations are to be carried out:
 - one at full load
 - one at the minimum load expected in service.
- For installations with controllable pitch propellers, two calculations are to be carried out:
 - one for full pitch condition
 - one for zero pitch condition.
- The calculations are to take into account all possible sources of excitation. Electrical sources of excitations, such as static frequency converters, are to be detailed.
- The natural frequencies are to be considered up to a value corresponding to 15 times the maximum service speed. Therefore, the excitations are to include harmonic orders up to the fifteenth.

3.4.3 Criteria for acceptance of the torsional vibration loads under normal firing conditions

- Torsional vibration stresses in the various shafts are not to exceed the limits defined in [3.5]. Higher limits calculated by an alternative method may be considered, subject to special examination by the Society.

The limit for continuous running τ_1 may be exceeded only in the case of transient running in restricted speed ranges, which are defined in [3.5.5]. In no case are the torsional vibration stresses to exceed the limit for transient running τ_2 .

Propulsion systems are to be capable of running continuously without restrictions at least within the speed range between $0,8 N_n$ and $1,05 N_n$. Transient running may be considered only in restricted speed ranges for speed ratios $\lambda \leq 0,8$.

Auxiliary machinery is to be capable of running continuously without restrictions at least within the range between $0,95 N_n$ and $1,1 N_n$. Transient running may be considered only in restricted speed ranges for speed ratios $\lambda \leq 0,95$.

- Torsional vibration levels in other components are to comply with the provisions of [3.6].

3.4.4 Criteria for acceptance of torsional vibration loads under misfiring conditions

- The provisions of [3.4.3] related to normal firing conditions also apply to misfiring conditions except that restricted speed ranges are also acceptable for $\lambda > 0,8$.

The restricted speed ranges in one-cylinder misfiring condition of single propulsion engine ships are to enable safe navigation.

- Where calculations show that the limits imposed for certain components may be exceeded under misfiring conditions, a suitable device is to be fitted to indicate the occurrence of such conditions.

3.5 Permissible limits for torsional vibration stresses in crankshaft, propulsion shafting and other transmission shafting

3.5.1 General

- a) The limits provided below apply to steel shafts. For shafts made of other material, the permissible limits for torsional vibration stresses will be determined by the Society after examination of the results of fatigue tests carried out on the material concerned.
- b) These limits apply to the torsional vibration stresses as defined in [3.3.1]. They relate to the shaft minimum section, without taking account of the possible stress concentrations.

3.5.2 Crankshaft

- a) Where the crankshaft has been designed in accordance with App 1, the torsional vibration stresses in any point of the crankshaft are not exceed the following limits:
- $\tau_1 = \tau_N$ for continuous running
 - $\tau_2 = 1,7 \tau_N$ for transient running,
- where τ_N is the nominal alternating torsional stress on which the crankshaft scantling is based (see [3.2.2], Note 1).
- b) Where the crankshaft has not been designed in accordance with App 1, the torsional vibration stresses in any point of the crankshaft are not to exceed the following limits:
- $\tau_1 = 0,55 \cdot C_R \cdot C_D \cdot C_\lambda$ for continuous running
 - $\tau_2 = 2,3 \tau_1$ for transient running.

3.5.3 Intermediate shafts, thrust shafts and propeller shafts

The torsional vibration stresses in any intermediate, thrust and propeller shafts are not to exceed the following limits:

- $\tau_1 = C_R \cdot C_k \cdot C_D \cdot C_\lambda$ for continuous running
- $\tau_2 = 1,7 \tau_1 \cdot C_k^{-0,5}$ for steady state conditions within barred speed range.

Note 1: For intermediate, thrust and propeller shafts, the material factor C_R is not to be taken as greater than 42,2.

3.5.4 Transmission shafting for generating sets and other auxiliary machinery

The torsional vibration stresses in the transmission shafting for generating sets and other auxiliary machinery, such as pumps or compressors, are not to exceed the following limits:

- $\tau_1 = 0,90 \cdot C_R \cdot C_D$ for continuous running
- $\tau_2 = 5,4 \tau_1$ for transient running.

3.5.5 Restricted speed ranges

- a) Where the stress amplitudes exceed the limiting values of τ_1 for continuous operation, including one cylinder misfiring conditions, restricted speed ranges are to be imposed which are to be passed through rapidly;
- b) restricted speed ranges in one-cylinder misfiring conditions of single propulsion engine ships are to enable safe navigation;

- c) the barred speed range is to cover all speeds where the acceptance limits (τ_1) are exceeded. For controllable pitch propellers with the possibility of individual pitch and speed control, both full and zero pitch conditions are to be considered.

Additionally, the tachometer tolerance is to be added. At each end of the barred speed range the engine is to be stable in operation;

- d) the limits of the restricted speed range related to a critical speed N_c are to be calculated in accordance with the following formula:

$$\frac{16 \cdot N_c}{18 - \lambda} \leq N \leq \frac{(18 - \lambda) \cdot N_c}{16}$$

- e) where the resonance curve of a critical speed is obtained from torsional vibration measurements, the restricted speed range may be established considering the speeds for which the stress limit for continuous running τ_1 is exceeded;
- f) where restricted speed ranges are imposed, they are to be crossed out on the tachometers and an instruction plate is to be fitted at the control stations indicating that:
- the continuous operation of the engine within the considered speed range is not permitted
 - this speed range is to be passed through rapidly.

3.6 Permissible vibration levels in components other than shafts

3.6.1 Gears

- a) The torsional vibration torque in any gear step is not to exceed 30% of the torque corresponding to the approved rating throughout the service speed range.

Where the torque transmitted at nominal speed is less than that corresponding to the approved rating, higher torsional vibration torques may be accepted, subject to special consideration by the Society.

- b) Gear hammering induced by torsional vibration torque reversal is not permitted throughout the service speed range, except during transient running at speed ratios $\lambda \leq 0,3$.

Where calculations show the existence of torsional vibration torque reversals for speed ratios $\lambda > 0,3$, the corresponding speed ranges are to be identified by appropriate investigations during sea trials and considered as restricted speed ranges in accordance with [3.5.5].

3.6.2 Generators

- a) In the case of alternating current generators, the torsional vibration amplitude at the rotor is not to exceed $\pm 2,5$ electrical degrees at service rotational speed under full load working conditions.

- b) Vibratory inertia torques due to torsional vibrations and imposed on the rotating parts of the generator are not to exceed the values M_A , in N.m, calculated by the following formulae, as appropriate:

- for $0,95 \leq \lambda \leq 1,1$: $M_A = \pm 2,5 M_T$
- for $\lambda \leq 0,95$: $M_A = \pm 6 M_T$,

where:

M_T : Mean torque transmitted by the engine under full load running conditions, in N.m

Note 1: In the case of two or more generators driven by the same engine, the portion of M_T transmitted to each generator is to be considered.

λ : Speed ratio defined in [3.3.2].

3.6.3 Flexible couplings

- a) Flexible couplings are to be capable of withstanding the mean transmitted torque and the torsional vibration torque throughout the service speed range, without exceeding the limits for continuous operation imposed by the manufacturer (permissible vibratory torque and power loss).

Where such limits are exceeded under misfiring conditions, appropriate restrictions of power or speed are to be established.

- b) Flexible couplings fitted in generating sets are also to be capable of withstanding the torques and twist angles arising from transient criticals and short-circuit currents.

3.6.4 Dampers

- a) Torsional vibration dampers are to be such that the permissible power loss recommended by the manufacturer is not exceeded throughout the service speed range.
- b) Dampers for which a failure may lead to a significant vibration overload of the installation will be the subject of special consideration.

3.7 Torsional vibration measurements

3.7.1 General

- a) The Society may require torsional vibration measurements to be carried out under its supervision in the following cases:
- where the calculations indicate the possibility of dangerous critical speeds in the operating speed range,
 - where doubts arise as to the actual stress amplitudes or critical speed location, or
 - where restricted speed ranges need to be verified.
- b) Where measurements are required, a comprehensive report including the analysis of the results is to be submitted to the Society.

3.7.2 Method of measurement

When measurements are required, the method of measurement is to be submitted to the Society for approval. The type

of measuring equipment and the location of the measurement points are to be specified.

4 Lateral vibrations of main propulsion systems

4.1 General

4.1.1 Main propulsion systems are to be free from excessive lateral vibration throughout the working speed range.

Failing this, provision is to be made to limit the vibration amplitudes by modifying the dynamic system or restricted speed ranges are to be imposed in the corresponding regions of speeds.

4.2 Calculations and measurements on board

4.2.1 Unless previous experience of similar installations proves it to be unnecessary, the Society, on the basis of the characteristics of the main propulsion system concerned, reserves the right to require lateral vibration calculations to be submitted and/or measurements on board to be taken using an apparatus accepted by the Society.

5 Axial vibrations of main propulsion systems

5.1 General

5.1.1 Main propulsion systems are to be free from excessive axial vibrations throughout the working speed range.

Failing this, provision is to be made to limit the vibration amplitudes by modifying the dynamic system, or restricted speed ranges are to be imposed in the corresponding regions of speeds.

5.2 Calculations and measurements on board

5.2.1 Unless previous experience of similar installations proves it to be unnecessary, the Society, on the basis of the characteristics of the main propulsion system concerned, reserves the right to require axial vibration calculations to be submitted and/or measurements on board to be taken using an apparatus accepted by the Society.

SECTION 8 PIPING SYSTEMS

1 General

1.1 Application

1.1.1

a) General requirements applying to all piping systems are contained in:

- [2] for their design and construction
- [3] for the welding of steel pipes
- [4] for the bending of pipes
- [5] for their arrangement and installation
- [20] for their certification, inspection and testing.

b) Specific requirements for ship piping systems and machinery piping systems are given in Articles [6] to [19].

1.2 Documentation to be submitted

1.2.1 Documents

The documents listed in Tab 1 are to be submitted.

1.2.2 Additional information

The information listed in Tab 2 is also to be submitted.

Table 1 : Documents to be submitted

No.	I/A (1)	Document (2)
1	A	Drawing showing the arrangement of the sea chests and ship side valves
2	A	Diagram of the bilge and ballast systems (in and outside machinery spaces)
3	A	Specification of the central priming system intended for bilge pumps, when provided
4	A	Diagram of the scuppers and sanitary discharge systems
5	A	Diagram of the air, sounding and overflow systems
6	A	Diagram of cooling systems (sea water and fresh water)
7	A	Diagram of fuel oil system
8	A	Drawings of the fuel oil tanks not forming part of the ship's structure
9	A	Diagram of the lubricating oil system
10	A	Diagram of the thermal oil system
11	A	Diagram of the hydraulic systems intended for essential services or located in machinery spaces
12	A	Diagram of steam system, including safety valve exhaust and drain pipes
13	A I	For high temperature steam pipes: <ul style="list-style-type: none"> • stress calculation note • drawing showing the actual arrangement of the piping in three dimensions
14	A	Diagram of the boiler feed water and condensate system
15	A	Diagram of the compressed air system
16	A	Diagram of the hydraulic and pneumatic remote control systems
17	A	Diagram of the remote level gauging system
18	I	Diagram of the exhaust gas system
19	A	Diagram of drip trays and gutterway draining system
20	A	Diagram of the oxyacetylene welding system
21	A	Drawings and specification of valves and accessories, where required in [2.7]
<p>(1) A = to be submitted for approval, in four copies; I = to be submitted for information, in duplicate.</p> <p>(2) Diagrams are also to include, where applicable, the (local and remote) control and monitoring systems and automation systems.</p>		

Table 2 : Information to be submitted

No.	I/A (1)	Document
1	I	Nature, service temperature and pressure of the fluids
2	A	Material, external diameter and wall thickness of the pipes
3	A	Type of the connections between pipe lengths, including details of the weldings, where provided
4	A	Material, type and size of the accessories
5	A	Capacity, prime mover and, when requested, location of the pumps
6	A	For plastic pipes: <ul style="list-style-type: none"> • the chemical composition • the physical and mechanical characteristics in function of temperature • the characteristics of inflammability and fire resistance • the resistance to the products intended to be conveyed
(1) A = to be submitted for approval, in four copies; I = to be submitted for information, in duplicate.		

1.3 Definitions

1.3.1 Piping and piping systems

- a) Piping includes pipes and their connections, flexible hoses and expansion joints, valves and their actuating systems, other accessories (filters, level gauges, etc.) and pump casings.
- b) Piping systems include piping and all the interfacing equipment such as tanks, pressure vessels, heat exchangers, pumps and centrifugal purifiers, but do not include boilers, turbines, internal combustion engines and reduction gears.

Note 1: The equipment other than piping is to be designed in accordance with the relevant Sections of Chapter 1.

1.3.2 Design pressure

- a) The design pressure of a piping system is the pressure considered by the manufacturer to determine the scantling of the system components. It is not to be taken less than the maximum working pressure expected in this system or the highest setting pressure of any safety valve or relief device, whichever is the greater.
- b) The design pressure of a boiler feed system is not to be less than 1,25 times the design pressure of the boiler or the maximum pressure expected in the feed piping, whichever is the greater.
- c) The design pressure of steam piping located upstream of pressure reducing valves (high pressure side) is not to be less than the setting pressure of the boiler or superheater safety valves.
- d) The design pressure of a piping system located on the low pressure side of a pressure reducing valve where no safety valve is provided is not to be less than the maximum pressure on the high pressure side of the pressure reducing valve.
- e) The design pressure of a piping system located on the delivery side of a pump or a compressor is not to be less than the setting pressure of the safety valve for displacement pumps or the maximum pressure resulting from the operating (head-capacity) curve for centrifugal pumps, whichever is the greater.

1.3.3 Design temperature

The design temperature of a piping system is the maximum temperature of the medium inside the system.

1.3.4 Flammable oils

Flammable oils include fuel oils, lubricating oils, thermal oils and hydraulic oils (having flashpoint lower than 150°C).

1.4 Symbols and units

1.4.1 The following symbols and related units are commonly used in this Section. Additional symbols, related to some formulae indicated in this Section, are listed wherever it is necessary.

p	: Design pressure, in MPa
T	: Design temperature, in °C
t	: Rule required minimum thickness, in mm
D	: Pipe external diameter, in mm.

1.5 Class of piping systems

1.5.1 Purpose of the classes of piping systems

Piping systems are subdivided into three classes, denoted as class I, class II and class III, for the purpose of acceptance of materials, selection of joints, heat treatment, welding, pressure testing and the certification of fittings.

1.5.2 Definitions of the classes of piping systems

- a) Classes I, II and III are defined in Tab 3
- b) The following systems are not covered by Tab 3:
 - cargo piping for oil tankers, and
 - fluids for refrigerating plants.

2 General requirements for design and construction

2.1 Materials

2.1.1 General

Materials to be used in piping systems are to be suitable for the medium and the service for which the piping is intended.

2.1.2 Use of metallic materials

- a) Metallic materials are to be used in accordance with Tab 4.
- b) Materials for class I and class II piping systems are to be manufactured and tested in accordance with the appropriate requirements of Part D.
- c) Materials for class III piping systems are to be manufactured and tested in accordance with the requirements of acceptable national or international standards or specifications.
- d) Mechanical characteristics required for metallic materials are specified in Part D.

2.1.3 Use of plastics

- a) Plastics may be used for piping systems belonging to class III in accordance with App 3. The use of plastics for other systems or in other conditions will be given special consideration.
- b) Plastics intended for piping systems dealt with in this Section are to be of a type approved by the Society.

2.2 Thickness of pressure piping

2.2.1 Calculation of the thickness of pressure pipes

- a) The thickness *t*, in mm, of pressure pipes is to be determined by the following formula but, in any case, is not to be less than the minimum thickness given in Tab 5 to Tab 8.

$$t = \frac{t_0 + b + c}{1 - \frac{a}{100}}$$

where:

*t*₀ : Coefficient, in mm, equal to

$$t_0 = \frac{p \cdot D}{2Ke + p}$$

with:

p and *D* : as defined in [1.4.1],

K : Permissible stress defined in [2.2.2],

e : Weld efficiency factor to be:

- equal to 1 for seamless pipes and pipes fabricated according to a welding procedure approved by the Society,
- specially considered by the Society for other welded pipes, depending on the service and the manufacture procedure.

b : Thickness reduction due to bending defined in [2.2.3], in mm

c : Corrosion allowance defined in [2.2.4], in mm

a : Negative manufacturing tolerance percentage:

- equal to 10 for copper and copper alloy pipes, cold drawn seamless steel pipes and steel pipes fabricated according to a welding procedure approved by the Society,
- equal to 12,5 for hot laminated seamless steel pipes,
- subject to special consideration by the Society in other cases.

- b) The thickness thus determined does not take into account the particular loads to which pipes may be subjected. Attention is to be drawn in particular to the case of high temperature and low temperature pipes.

Table 3 : Class of piping systems

Media conveyed by the piping system	CLASS I	CLASS II	CLASS III
Fuel oil (1)	$p > 1,6$ or $T > 150$	other (2)	$p \leq 0,7$ and $T \leq 60$
Thermal oil	$p > 1,6$ or $T > 300$	other (2)	$p \leq 0,7$ and $T \leq 150$
Flammable Hydraulic oil (5)	$p > 1,6$ or $T > 150$	other (2)	$p \leq 0,7$ and $T \leq 60$
Lubricating oil	$p > 1,6$ or $T > 150$	other (2)	$p \leq 0,7$ and $T \leq 60$
Other flammable media: • heated above flashpoint, or • having flashpoint $< 60^{\circ}\text{C}$ and liquefied gas	without special safeguards (3)	with special safeguards (3)	
Oxyacetylene	irrespective of p		
Toxic media	irrespective of p, T		
Corrosive media	without special safeguards (3)	with special safeguards (3)	
Steam	$p > 1,6$ or $T > 300$	other (2)	$p \leq 0,7$ and $T \leq 170$
Air, gases, water, non-flammable hydraulic oil (4)	$p > 4$ or $T > 300$	other (2)	$p \leq 1,6$ and $T \leq 200$
Open-ended pipes (drains, overflows, vents, exhaust gas lines, boiler escape pipes)			irrespective of T
<p>(1) Valves under static pressure on fuel oil tanks belong to class II.</p> <p>(2) Pressure and temperature conditions other than those required for class I and class III.</p> <p>(3) Safeguards for reducing the possibility of leakage and limiting its consequences, e.g. pipes led in positions where leakage of internal fluids will not cause a potential hazard or damage to surrounding areas which may include the use of pipe ducts, shielding, screening, etc.</p> <p>(4) Valves and fittings fitted on the ship side and collision bulkhead belong to class II.</p> <p>(5) Steering gear piping belongs to class I irrespective of p and T</p> <p>Note 1: p : Design pressure, as defined in [1.3.2], in MPa.</p> <p>Note 2: T : Design temperature, as defined in [1.3.3], in $^{\circ}\text{C}$.</p>			

Table 4 : Conditions of use of metallic materials in piping systems

Material	Allowable classes	Maximum design temperature (°C) (1)	Particular conditions of use
Carbon and carbon-manganese steels	III, II, I	400 (2)	Class I and II pipes are to be seamless drawn pipes (3)
Copper and aluminium brass	III, II, I	200	(4)
Copper-nickel	III, II, I	300	
Special high temperature resistant bronze	III, II, I	260	
Stainless steel	III, II, I	300	Austenitic stainless steel is not recommended for sea water systems
Spheroidal graphite cast iron	III, II	350	<ul style="list-style-type: none"> Spheroidal cast iron of the ferritic type according to the material rules of the Society may be accepted for bilge, ballast and cargo oil piping The use of this material for pipes, valves and fittings for other services, in principle Classes II and III, will be subject to special consideration Spheroidal cast iron pipes and valves fitted on ship's side should have specified properties to the Society's satisfaction, according to the intention of Regulation 22 of the 1966 Convention on Load Lines Minimum elongation is not to be less than 12% on a gauge length of $5,65.S^{0,5}$, where S is the actual cross-sectional area of the test piece
Grey cast iron	III II (5)	220	<p>Grey cast iron is not to be used for the following systems:</p> <ul style="list-style-type: none"> boiler blow-down systems and other piping systems subject to shocks, high stresses and vibrations bilge lines in tanks parts of scuppers and sanitary discharge systems located next to the hull below the freeboard deck or for passenger ships below the bulkhead deck ship side valves and fittings valves fitted on the collision bulkhead valves fitted to fuel oil and lubricating oil tanks under static pressure head class II fuel oil systems thermal oil systems
Aluminium and aluminium alloys	III, II, I (6)	200	<p>Aluminium and aluminium alloys are not to be used on the following systems:</p> <ul style="list-style-type: none"> flammable oil systems (6) sounding and air pipes of fuel oil tanks fire-extinguishing systems bilge system in boiler or machinery spaces or in spaces containing fuel oil tanks or pumping units scuppers and overboard discharges except for pipes led to the bottoms or to the shell above the freeboard deck or fitted at their upper end with closing means operated from a position above the freeboard deck boiler blow-down valves and pieces for connection to the shell plating.

(1) Maximum design temperature is not to exceed that assigned to the class of piping.
(2) Higher temperatures may be accepted if metallurgical behaviour and time dependent strength (ultimate tensile strength after 100000 hours) are in accordance with national or international standards or specifications and if such values are guaranteed by the steel manufacturer.
(3) Pipes fabricated by a welding procedure approved by the Society may also be used.
(4) Pipes made of copper and copper alloys are to be seamless.
(5) Use of grey cast iron is not allowed when the design pressure exceeds 1,3 MPa.
(6) Accessories of aluminium or aluminium alloys intended for flammable oil systems may be accepted subject to the satisfactory result of an endurance flame test to be carried out according to the "Rules for the type approval of flexible hoses and expansion joints" issued by the Society.

Note 1: On board oil tankers aluminised pipes may be permitted in ballast tanks, in inerted cargo tanks and, provided the pipes are protected from accidental impact, in hazardous areas on open deck.

Table 5 : Minimum wall thickness for steel pipes

External diameter (mm)	Minimum nominal wall thickness (mm)		Minimum reinforced wall thickness (mm) (2)	Minimum extra-reinforced wall thickness (mm) (3)
	Sea water pipes, bilge and ballast systems (1)	Other piping systems (1)		
10,2 - 12,0	-	1,6	-	-
13,5 - 19,3	-	1,8	-	-
20,0	-	2,0	-	-
21,3 - 25,0	3,2	2,0	-	-
26,9 - 33,7	3,2	2,0	-	-
38,0 - 44,5	3,6	2,0	6,3	7,6
48,3	3,6	2,3	6,3	7,6
51,0 - 63,5	4,0	2,3	6,3	7,6
70,0	4,0	2,6	6,3	7,6
76,1 - 82,5	4,5	2,6	6,3	7,6
88,9 - 108,0	4,5	2,9	7,1	7,8
114,3 - 127,0	4,5	3,2	8,0	8,8
133,0 - 139,7	4,5	3,6	8,0	9,5
152,4 - 168,3	4,5	4,0	8,8	11,0
177,8	5,0	4,5	8,8	12,7
193,7	5,4	4,5	8,8	12,7
219,1	5,9	4,5	8,8	12,7
244,5 - 273,0	6,3	5,0	8,8	12,7
298,5 - 368,0	6,3	5,6	8,8	12,7
406,4 - 457,2	6,3	6,3	8,8	12,7

(1) Attention is drawn to the special requirements regarding:

- bilge and ballast systems
- scupper and discharge pipes
- sounding, air and overflow pipes
- ventilation systems
- oxyacetylene welding systems
- CO₂ fire-extinguishing systems (see Ch 4, Sec 1)

(2) Reinforced wall thickness applies to bilge, ballast, vent, overflow and sounding pipes passing through fuel tank and bilge, vent, overflow, sounding and fuel pipes passing through ballast tanks.

(3) Extra-reinforced wall thickness applies to pipes connected to the shell.

Note 1: A different thickness may be considered by the Society on a case by case basis, provided that it complies with recognised standards.

Note 2: Where pipes and any integral pipe joints are protected against corrosion by means coating, lining, etc. at the discretion of the Society, thickness may be reduced by not more than 1 mm.

Note 3: The thickness of threaded pipes is to be measured at the bottom of the thread.

Note 4: The minimum thickness listed in this table is the nominal wall thickness and no allowance is required for negative tolerance or reduction in thickness due to bending.

Note 5: The minimum wall thickness for pipes larger than 450 mm nominal size is to be in accordance with a national or international standard and in any case not less than the minimum wall thickness of the appropriate column indicated for 450 mm pipe size.

Table 6 : Minimum wall thickness for copper and copper alloy pipes

External diameter (mm)	Minimum wall thickness (mm)	
	Copper	Copper alloy
8 - 10	1,0	0,8
12 - 20	1,2	1,0
25 - 44,5	1,5	1,2
50 - 76,1	2,0	1,5
88,9 - 108	2,5	2,0
133 - 159	3,0	2,5
193,7 - 267	3,5	3,0
273 - 457,2	4,0	3,5
470	4,0	3,5
508	4,5	4,0

Note 1: A different thickness may be considered by the Society on a case by case basis, provided that it complies with recognised standards.

Table 7 : Minimum wall thickness for stainless steel pipes

External diameter (mm)	Minimum wall thickness (mm)
up to 17,2	1,0
up to 48,3	1,6
up to 88,9	2,0
up to 168,3	2,3
up to 219,1	2,6
up to 273,0	2,9
up to 406,4	3,6
over 406,4	4

Note 1: A different thickness may be considered by the Society on a case by case basis, provided that it complies with recognised standards.

Table 8 : Minimum wall thickness for aluminium and aluminium alloy pipes

External diameter (mm)	Minimum wall thickness (mm)
0 - 10	1,5
12 - 38	2,0
43 - 57	2,5
76 - 89	3,0
108 - 133	4,0
159 - 194	4,5
219 - 273	5,0
above 273	5,5

Note 1: A different thickness may be considered by the Society on a case by case basis, provided that it complies with recognised standards.

Note 2: For sea water pipes, the minimum thickness is not to be less than 5 mm.

2.2.2 Permissible stress

a) The permissible stress K is given:

- in Tab 9 for carbon and carbon-manganese steel pipes,
- in Tab 10 for alloy steel pipes, and
- in Tab 11 for copper and copper alloy pipes,

as a function of the temperature. Intermediate values may be obtained by interpolation.

b) Where, for carbon steel and alloy steel pipes, the value of the permissible stress K is not given in Tab 9 or Tab 10, it is to be taken equal to the lowest of the following values:

$$\frac{R_{m,20}}{2,7} \quad \frac{R_e}{A} \quad \frac{S_R}{A} \quad S$$

where:

$R_{m,20}$: Minimum tensile strength of the material at ambient temperature (20°C), in N/mm²

R_e : Minimum yield strength or 0,2% proof stress at the design temperature, in N/mm²

S_R : Average stress to produce rupture in 100000 h at design temperature, in N/mm²

S : Average stress to produce 1% creep in 100000 h at design temperature, in N/mm²

A : Safety factor to be taken equal to:

- 1,6 when R_e and S_R values result from tests attended by the Society,
- 1,8 otherwise.

c) The permissible stress values adopted for materials other than carbon steel, alloy steel, copper and copper alloy will be specially considered by the Society.

2.2.3 Thickness reduction due to bending

a) Unless otherwise justified, the thickness reduction b due to bending is to be determined by the following formula:

$$b = \frac{Dt_0}{2,5\rho}$$

where:

ρ : Bending radius measured on the centre line of the pipe, in mm

D : as defined in [1.4.1]

t_0 : as defined in [2.2.1].

b) When the bending radius is not given, the thickness reduction is to be taken equal to:

$$\frac{t_0}{10}$$

c) For straight pipes, the thickness reduction is to be taken equal to 0.

2.2.4 Corrosion allowance

The values of corrosion allowance c are given for steel pipes in Tab 12 and for non-ferrous metallic pipes in Tab 13.

Table 9 : Permissible stresses for carbon and carbon-manganese steel pipes

Specified minimum tensile strength (N/mm ²)	Design temperature (°C)												
	≤50	100	150	200	250	300	350	400	410	420	430	440	450
320	107	105	99	92	78	62	57	55	55	54	54	54	49
360	120	117	110	103	91	76	69	68	68	68	64	56	49
410	136	131	124	117	106	93	86	84	79	71	64	56	49
460	151	146	139	132	122	111	101	99	98	85	73	62	53
490	160	156	148	141	131	121	111	109	98	85	73	62	53

Table 10 : Permissible stresses for alloy steel pipes

Type of steel	Specified minimum tensile strength (N/mm ²)	Design temperature (°C)											
		≤50	100	200	300	350	400	440	450	460	470		
1Cr1/2Mo	440	159	150	137	114	106	102	101	101	100	99		
2 1/4Cr1Mo annealed	410	76	67	57	50	47	45	44	43	43	42		
2 1/4Cr1Mo normalised and tempered below 750°C	490	167	163	153	144	140	136	130	128	127	116		
2 1/4Cr1Mo normalised and tempered above 750°C	490	167	163	153	144	140	136	130	122	114	105		
1/2Cr 1/2Mo 1/4V	460	166	162	147	120	115	111	106	105	103	102		

Type of steel	Specified minimum tensile strength (N/mm ²)	Design temperature (°C)											
		480	490	500	510	520	530	540	550	560	570		
1Cr1/2Mo	440	98	97	91	76	62	51	42	34	27	22		
2 1/4Cr1Mo annealed	410	42	42	41	41	41	40	40	40	37	32		
2 1/4Cr1Mo normalised and tempered below 750°C	490	106	96	86	79	67	58	49	43	37	32		
2 1/4Cr1Mo normalised and tempered above 750°C	490	96	88	79	72	64	56	49	43	37	32		
1/2Cr 1/2Mo 1/4V	460	101	99	97	94	82	72	62	53	45	37		

Table 11 : Permissible stresses for copper and copper alloy pipes

Material (annealed)	Specified minimum tensile strength (N/mm ²)	Design temperature (°C)										
		≤50	75	100	125	150	175	200	225	250	275	300
Copper	215	41	41	40	40	34	27,5	18,5				
Aluminium brass	325	78	78	78	78	78	51	24,5				
Copper-nickel 95/5 and 90/10	275	68	68	67	65,5	64	62	59	56	52	48	44
Copper-nickel 70/30	365	81	79	77	75	73	71	69	67	65,5	64	62

Table 12 : Corrosion allowance for steel pipes

Piping system	Corrosion allowance (mm)
Superheated steam	0,3
Saturated steam	0,8
Steam coils in cargo tanks and liquid fuel tanks	2,0
Feed water for boilers in open circuit systems	1,5
Feed water for boilers in closed circuit systems	0,5
Blow-down systems for boilers	1,5
Compressed air	1,0
Hydraulic oil	0,3
Lubricating oil	0,3
Fuel oil	1,0
Thermal oil	1,0
Fresh water	0,8
Sea water	3,0
Refrigerants referred to in Section 13	0,3
Cargo systems for oil tankers	2,0
Cargo systems for ships carrying liquefied gases	0,3

Note 1: For pipes passing through tanks, an additional corrosion allowance is to be considered in order to account for the external corrosion.

Note 2: The corrosion allowance may be reduced where pipes and any integral pipe joints are protected against corrosion by means of coating, lining, etc.

Note 3: When the corrosion resistance of alloy steels is adequately demonstrated, the corrosion allowance may be disregarded.

Table 13 : Corrosion allowance for non-ferrous metal pipes

Piping material (1)	Corrosion allowance (mm) (2)
Copper	0,8
Brass	0,8
Copper-tin alloys	0,8
Copper-nickel alloys with less than 10% of Ni	0,8
Copper-nickel alloys with at least 10% of Ni	0,5
Aluminium and aluminium alloys	0,5

(1) The corrosion allowance for other materials will be specially considered by the Society. Where their resistance to corrosion is adequately demonstrated, the corrosion allowance may be disregarded.

(2) In cases of media with high corrosive action, a higher corrosion allowance may be required by the Society.

2.2.5 Tees

As well as complying with the provisions of [2.2.1] to [2.2.4] above, the thickness t_T of pipes on which a branch is welded to form a Tee is not to be less than that given by the following formula:

$$t_T = \left(1 + \frac{D_1}{D}\right) \cdot t_0$$

where:

D_1 : External diameter of the branch pipe

D : as defined in [1.4.1]

t_0 : as defined in [2.2.1]

Note 1: This requirement may be dispensed with for Tees provided with a reinforcement or extruded.

2.3 Calculation of high temperature pipes

2.3.1 General

For main steam piping having a design temperature exceeding 400°C, calculations are to be submitted to the Society concerning the stresses due to internal pressure, piping weight and any other external load, and to thermal expansion, for all cases of actual operation and for all lengths of piping.

The calculations are to include, in particular:

- the components, along the three principal axes, of the forces and moments acting on each branch of piping
- the components of the displacements and rotations causing the above forces and moments
- all parameters necessary for the computation of forces, moments and stresses.

In way of bends, the calculations are to be carried out taking into account, where necessary, the pipe ovalisation and its effects on flexibility and stress increase.

A certain amount of cold springing, calculated on the basis of expected thermal expansion, is to be applied to the piping during installation. Such springing is to be neglected in stress calculations; it may, however, be taken into account in terms of its effect on thrusts on turbines and other parts.

2.3.2 Thermal stress

The combined stress σ_{ID} , in N/mm², due to thermal expansion, calculated by the following formula:

$$\sigma_{ID} = (\sigma^2 + 4\tau^2)^{0,5}$$

is to be such as to satisfy the following equation:

$$\sigma_{ID} \leq 0,75K_{20} + 0,25K_T$$

where:

σ : Value of the longitudinal stress due to bending moments caused by thermal expansion, increased, if necessary, by adequate factors for bends, in N/mm²; in general it is not necessary to take account of the effect of axial force

τ : Value of the tangential stress due to torque caused by thermal expansion, in N/mm²; in general it is not necessary to take account of the effect of shear force

- K_{20} : Value of the permissible stress for the material employed, calculated according to [2.2.2], for a temperature of 20°C, in N/mm²
- K_T : Value of the permissible stress for the material employed, calculated according to [2.2.2], for the design temperature T, in N/mm².

2.3.3 Longitudinal stresses

The sum of longitudinal stresses σ_L , in N/mm², due to pressure, piping weight and any other external loads is to be such as to satisfy the following equation:

$$\sigma_L \leq K_T$$

where K_T is defined in [2.3.2].

2.3.4 Alternative limits for permissible stresses

Alternative limits for permissible stresses may be considered by the Society in special cases or when calculations have been carried out following a procedure based on hypotheses other than those considered above.

2.4 Junction of pipes

2.4.1 General

- The number of joints in flammable oil piping systems is to be kept to the minimum necessary for mounting and dismantling purposes.
- Direct connections of pipe lengths may be made by direct welding, flanges, threaded joints or mechanical joints, and are to be to a recognised standard or of a design proven to be suitable for the intended purpose and acceptable to the Society.
The expression "mechanical joints" means devices intended for direct connection of pipe lengths other than by welding, flanges or threaded joints described in [2.4.2], [2.4.3] and [2.4.4] below.
- The gaskets and packings used for the joints are to suit the design pressure, the design temperature and the nature of the fluids conveyed.
- The junction between plastic pipes is to comply with App 3.

2.4.2 Welded connections

- Welding and non destructive testing of welds are to be carried out in accordance with [3]. Welded joints are to be used in accordance with Tab 15.

- Butt-welded joints are to be of full penetration type with or without special provision for a high quality of root side.

The expression "special provision for a high quality of root side" means that butt welds were accomplished as double welded or by use of a backing ring or inert gas back-up on first pass, or other similar methods accepted by the Society.

Butt welded joints with special provision for a high quality of root side may be used for piping of any Class and any outside diameter.

- Slip-on sleeve and socket welded joints are to have sleeves, sockets and weldments of adequate dimensions conforming to a standard recognised by the Society.

2.4.3 Flange connections

- The dimensions and configuration of flanges and bolts are to be chosen in accordance with a Standard recognised by the Society. This standard is to cover the design pressure and design temperature of the piping system.
- For non-standard flanges the dimensions of flanges and bolts are subject to special consideration by the Society.
- Flange material is to be suitable for the nature and temperature of the fluid, as well as for the material of the pipe on which the flange is to be attached.
- Flanges are to be attached to the pipes by welding or screwing in accordance with one of the designs shown in Fig 1.

Permitted applications are indicated in Tab 14. However the Society may accept flange attachments in accordance with national or international standards that are applicable to the piping system and recognise the boundary fluids, design pressure and temperature conditions, external or cyclic loading and location.

2.4.4 Slip-on threaded joints

Slip-on threaded joints having pipe threads where pressure-tight joints are made on the threads with parallel or tapered threads, are to comply with requirements of a recognised national or international standard.

Slip-on threaded joints are to be used according to Tab 15.

Figure 1 : Types of metallic flange connections

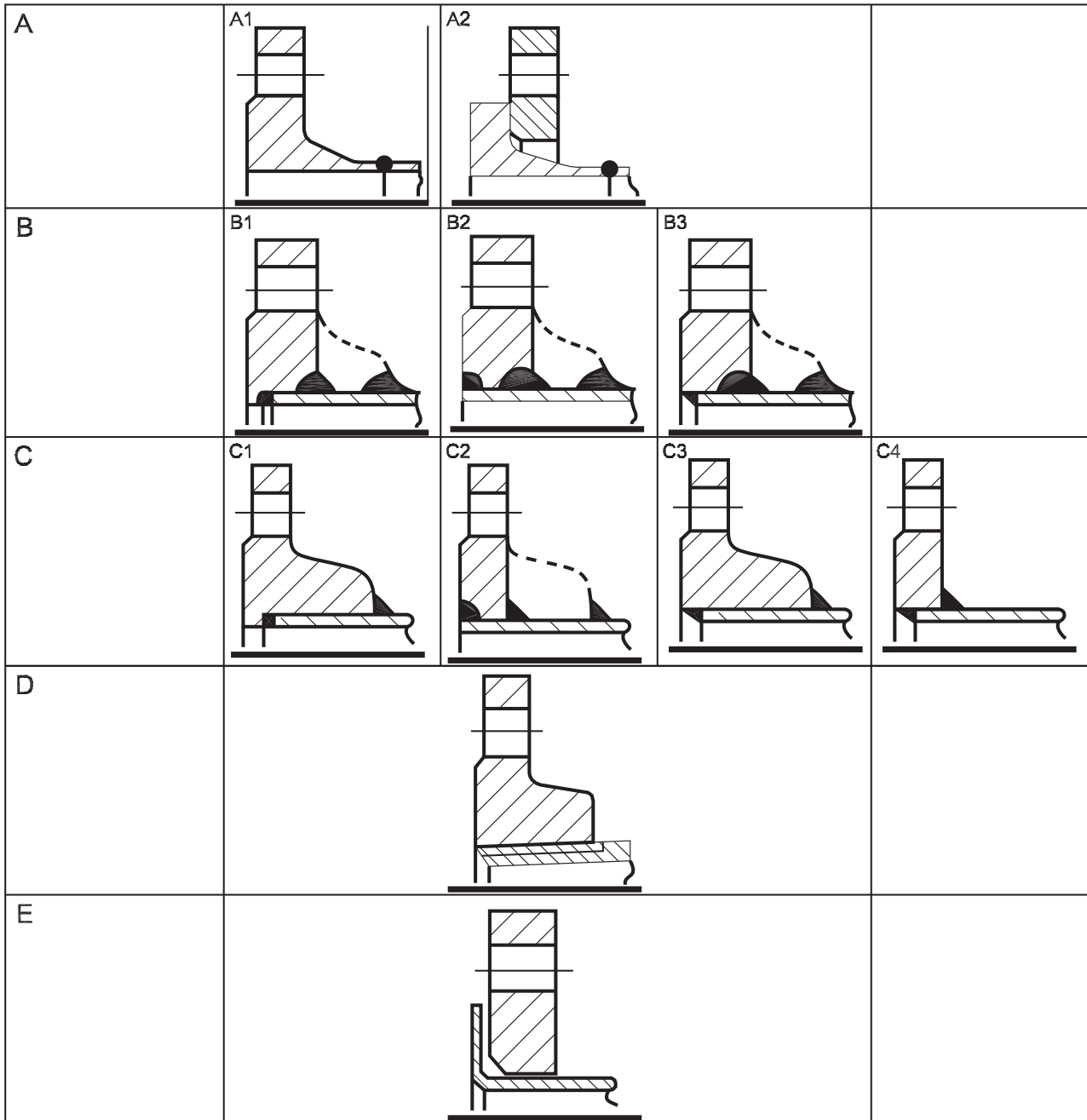

Note 1: For type D, the pipe and flange are to be screwed with a tapered thread and the diameter of the screw portion of the pipe over the thread is not to be appreciably less than the outside diameter of the unthreaded pipe. For certain types of thread, after the flange has been screwed hard home, the pipe is to be expanded into the flange.

Note 2: For connections (C1), (C2), (C3) and (C4) the leg length of the fillet weld is to be in general equal to 1,5 times the pipe thickness but in no case is to be less than 6 mm.

Note 3: For connections (B1), (B2), (B3) and (C2) the dimension of the groove penetration in the flange is to be in general equal to the pipe thickness but in no case is to be less than 5 mm.

Table 14 : Types of flange connections required in relation to the class of piping and the type of media conveyed (1)

Class of piping → Type of media conveyed ↓	Class I	Class II	Class III
Toxic or corrosive media, flammable liquid media	(A1)-(A2)-(B1)-(B2)-(B3) (2) (3)	(A1)-(A2)-(B1)-(B2)-(B3)-(C1)-(C2)-(C3) (2)	(A1)-(A2)-(B1)-(B2)-(B3)-(C1)-(C2)-(C3) (2)
Lubricating and fuel oil	(A1)-(A2)-(B1)-(B2)-(B3)	(A1)-(A2)-(B1)-(B2)-(B3) - (C1)-(C2)-(C3)-(C4) (4)	(A1)-(A2)-(B1)-(B2)-(B3)-(C1)-(C2)-(C3)-(C4)
Steam and thermal oil	(A1)-(A2)-(B1)-(B2)-(B3) (3) (5)	(A1)-(A2)-(B1)-(B2)-(B3) - (C1)-(C2)-(C3)-(C4)-(D) (6)	(A1)-(A2)-(B1)-(B2)-(B3)-(C1)-(C2)-(C3)-(C4)-(D)
Other media, including water, air, gases, refrigerants, non flammable hydraulic oil (7)	(A1)-(A2)-(B1)-(B2)-(B3) (5)	(A1)-(A2)-(B1)-(B2)-(B3) - (C1)-(C2)-(C3)-(C4)-(D) (6)	(A1)-(A2)-(B1)-(B2)-(B3)-(C1)-(C2)-(C3)-(C4)-(D)-(E) (8)

(1) The types of flange connections given in the Table are those shown in Fig 1.
(2) Only type (A1) and (A2) flange connections are to be adopted for piping conveying flammable, toxic or corrosive liquid media or liquefied gases having a design pressure **p** (see item [1.3.2]) higher than 1 N/mm².
(3) For piping having a nominal diameter equal to or greater than 150 mm, only type (A1) and (A2) flange connections are to be adopted.
(4) Flange connections of type (C4) are only acceptable for piping having a design pressure **p** less than 1,6 N/mm² and design temperature **T** (see item [1.3.3]) less than 150°C.
(5) Only type (A1) and (A2) flange connections are to be adopted for piping having a design temperature **T** higher than 400°C.
(6) Flange connections of types (D) and (C4) are not acceptable for piping having a design temperature **T** exceeding 250°C.
(7) For piping of hydraulic power plants of steering gears, only flange connections of types required for Class I piping are to be used.
(8) Flange connections of type (E) are only acceptable for water piping and open ended lines (e.g. drain, overflow, air vent piping, etc.).

Table 15 : Use of welded and threaded metallic joints in piping systems

	Permitted classes of piping	Restrictions of use
Butt-welded joint (1)	III, II, I	no restrictions
Slip-on sleeve joint (2)	III	no restrictions
Sleeve threaded joint (tapered thread) (3)	I	not allowed for: <ul style="list-style-type: none"> • pipes with outside diameter of more than 33,7 mm • pipes inside tanks • piping systems conveying toxic or flammable media or services where fatigue, severe erosion or crevice corrosion is expected to occur.
	II, III	not allowed for: <ul style="list-style-type: none"> • pipes with outside diameter of more than 60,3 mm • pipes inside tanks • piping systems conveying toxic or flammable media or services where fatigue, severe erosion or crevice corrosion is expected to occur.
Sleeve threaded joint (parallel thread) (3)	III	not allowed for: <ul style="list-style-type: none"> • pipes with outside diameter of more than 60,3 mm • pipes inside tanks • piping systems conveying toxic or flammable media or services where fatigue, severe erosion or crevice corrosion is expected to occur.

(1) Welded butt-joints without special provisions for root side may be used for Classes II and III, any outside diameter.
(2) In particular cases, slip-on sleeve and socket welded joints may be allowed by the Society for piping systems of Class I and II having outside diameter ≤ 88,9 mm except for piping systems conveying toxic media or services where fatigue, severe erosion or crevice corrosion is expected to occur.
(3) In particular cases, sizes in excess of those mentioned above may be accepted by the Society if in compliance with a recognised national and/or international standard.

2.4.5 Mechanical joints

Due to the great variations in design and configuration of mechanical joints, no specific recommendation regarding the method for theoretical strength calculations is given in these requirements. The mechanical joints are to be type approved by the Society according to the "Rules for the type approval of mechanical joints for pipes".

These requirements are applicable to pipe unions, compression couplings and slip-on joints as shown in Fig 2. Similar joints complying with these requirements may be acceptable.

The application and pressure ratings of different mechanical joints are to be approved by the Society.

Mechanical joints including pipe unions, compression couplings, slip-on joints and similar joints are to be of approved type for the service conditions and the intended application.

Where the application of mechanical joints results in reduction in pipe wall thickness due to the use of bite type rings or other structural elements, this is to be taken into account in determining the minimum wall thickness of the pipe to withstand the design pressure.

Construction of mechanical joints is to prevent the possibility of tightness failure affected by pressure pulsation, piping vibration, temperature variation and other similar adverse effects occurring during operation on board.

Material of mechanical joints is to be compatible with the piping material and internal and external media.

Mechanical joints are to be tested where applicable, to a burst pressure of 4 times the design pressure.

For design pressures above 20 MPa the required burst pressure will be specially considered by the Society.

In general, mechanical joints are to be of fire-resistant type as required by Tab 16.

Mechanical joints which in the event of damage could cause fire or flooding are not to be used in piping sections directly connected to sea openings or tanks containing flammable fluids.

Mechanical joints are to be designed to withstand internal and external pressure as applicable and where used in suction lines are to be capable of operating under vacuum.

The number of mechanical joints in oil systems is to be kept to a minimum. In general, flanged joints conforming to recognised standards are to be used.

Piping in which a mechanical joint is fitted is to be adequately adjusted, aligned and supported. Supports or hangers are not to be used to force alignment of piping at the point of connection.

Slip-on joints are not to be used in pipelines in cargo holds, tanks, and other spaces which are not easily accessible, unless approved by the Society.

The application of these joints inside tanks may be permitted only for the same media that is in the tanks.

Unrestrained slip-on joints are to be used only in cases where compensation of lateral pipe deformation is necessary. Usage of these joints as the main means of pipe connection is not permitted.

Application of mechanical joints and their acceptable use for each service are indicated in Tab 16; dependence upon the Class of piping, pipe dimensions, working pressure and temperature are indicated in Tab 17.

In particular, Tab 16 indicates systems where the various kinds of joints may be accepted. However, in all cases, acceptance of the joint type is to be subject to approval of the intended application, and subject to conditions of the approval and applicable requirements.

In particular cases, sizes in excess of those mentioned above may be accepted if in compliance with a national and/or international standard recognised by the Society.

Mechanical joints are to be tested in accordance with a program approved by the Society, which is to include at least the following:

- a) leakage test
- b) vacuum test (where necessary)
- c) vibration (fatigue) test
- d) fire endurance test (where necessary)
- e) burst pressure test
- f) pressure pulsation test (where necessary)
- g) assembly test (where necessary)
- h) pull out test (where necessary).

The installation of mechanical joints is to be in accordance with the Manufacturer's assembly instructions. Where special tools and gauges are required for installation of the joints, these are to be supplied by the Manufacturer.

Figure 2 : Examples of mechanical joints

Pipe Unions		Slip-on Joints	
Welded and Brazed Types		Grip Type	
Compression couplings		Machine Grooved type	
Swage Type		Slip Type	
Press Type			
Bite Type			
Flared Type			

Table 16 : Application of mechanical joints

System		Kind of connections		
		Pipe Unions	Compression Couplings (6)	Slip-on Joints
Flammable fluids (Flash point ≤ 60°)				
1	Cargo oil lines	yes	yes	yes (5)
2	Crude oil washing lines	yes	yes	yes (5)
3	Vent lines	yes	yes	yes (3)
Inert gas				
4	Water seal effluent lines	yes	yes	yes
5	Scrubber effluent lines	yes	yes	yes
6	Main lines	yes	yes	yes (2) (5)
7	Distributions lines	yes	yes	yes (5)
Flammable fluids (Flash point > 60°)				
8	Cargo oil lines	yes	yes	yes (5)
9	Fuel oil lines	yes	yes	yes (3) (2)
10	Lubricating oil lines	yes	yes	yes (2) (3)
11	Hydraulic oil	yes	yes	yes (2) (3)
12	Thermal oil	yes	yes	yes (2) (3)
Sea Water				
13	Bilge lines	yes	yes	yes (1)
14	Fire main and water spray	yes	yes	yes (3)
15	Foam system	yes	yes	yes (3)
16	Sprinkler system	yes	yes	yes (3)
17	Ballast system	yes	yes	yes (1)
18	Cooling water system	yes	yes	yes (1)
19	Tank cleaning services	yes	yes	yes
20	Non-essential systems	yes	yes	yes
Fresh water				
21	Cooling water system	yes	yes	yes (1)
22	Condensate return	yes	yes	yes (1)
23	Non-essential system	yes	yes	yes
Sanitary/Drains/Scuppers				
24	Deck drains (internal)	yes	yes	yes (4)
25	Sanitary drains	yes	yes	yes
26	Scuppers and discharge (overboard)	yes	yes	not
Sounding/Vent				
27	Water tanks/Dry spaces	yes	yes	yes
28	Oil tanks (f.p.> 60°C)	yes	yes	yes (2) (3)
Miscellaneous				
29	Starting/Control air (1)	yes	yes	not
30	Service air (non-essential)	yes	yes	yes
31	Brine	yes	yes	yes
32	CO ₂ system (1)	yes	yes	not
33	Steam	yes	yes	yes (7)

yes means application is allowed

not means application is not allowed

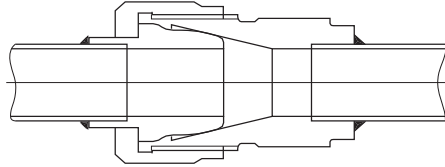
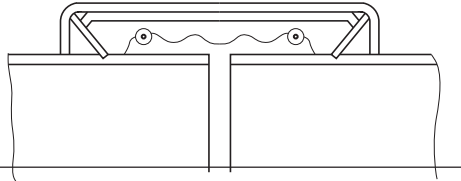
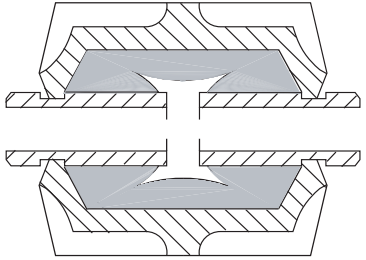
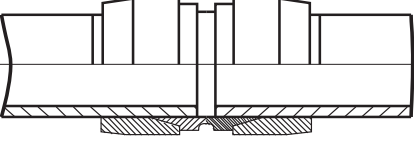
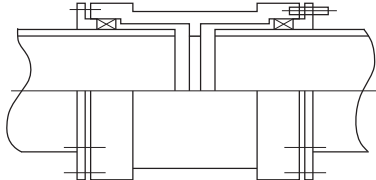
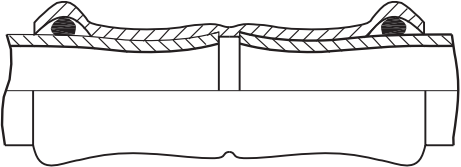
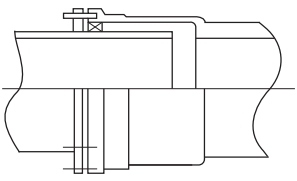
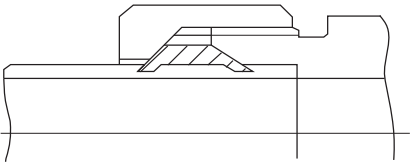
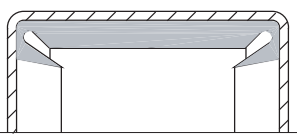
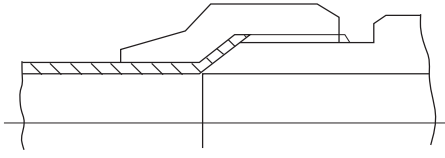
(1) Inside machinery spaces of category A - only approved fire resistant types

(2) Not inside machinery spaces of category A or accommodation spaces. May be accepted in other machinery spaces provided the joints are located in easily visible and accessible positions.

(3) Approved fire resistant types

(4) Above free board deck only

(5) In pump rooms and open decks - only approved fire resistant types

(6) If Compression Couplings include any components which readily deteriorate in case of fire, they are to be of approved fire resistant type as required for Slip-on joints.

(7) Provided that they are restrained on the pipes, they may be used for pipes on deck with a design pressure of 1,0 MPa or less

Table 17 : Application of mechanical joints depending upon the class of piping

Types of joints	Classes of piping systems		
	Class I	Class II	Class III
Pipe Unions			
Welded and brazed type	yes (outside diameter ≤ 60.3mm)	yes (outside diameter ≤ 60.3mm)	yes
Compression Couplings			
Swage type	yes	yes	yes
Bite type	yes (outside diameter ≤ 60.3mm)	yes (outside diameter ≤ 60.3mm)	yes
Flared type	yes (outside diameter ≤ 60.3mm)	yes (outside diameter ≤ 60.3mm)	yes
Press type	not	not	yes
Slip-on joints			
Machine grooved type	yes	yes	yes
Grip type	not	yes	yes
Slip type	not	yes	yes
yes means application is allowed not means application is not allowed			

2.5 Protection against overpressure

2.5.1 General

- These requirements deal with the protection of piping systems against overpressure, with the exception of heat exchangers and pressure vessels, which are dealt with in Sec 3, [2.4].
- Safety valves are to be sealed after setting.

2.5.2 Protection of flammable oil systems

Provisions shall be made to prevent overpressure in any flammable oil tank or in any part of the flammable oil systems, including the filling pipes served by pumps on board.

2.5.3 Protection of pump and compressor discharges

- Provisions are to be made so that the discharge pressure of pumps and compressors cannot exceed the pressure for which the pipes located on the discharge of these pumps and compressors are designed.
- When provided on the pump discharge for this purpose, safety valves are to lead back to the pump suction or to any other suitable place.
- The discharge capacity of the safety valves installed on pumps and compressors is to be such that the pressure at the discharge side cannot exceed by more than 10% the design pressure of the discharge pipe in the event of operation with closed discharge.

2.5.4 Protection of pipes

- Pipes likely to be subjected to a pressure exceeding their normal working pressure are to be provided with safety valves or equivalent overpressure protecting devices.
- In particular, pipes located on the low pressure side of pressure reducing valves are to be provided with safety

valves unless they are designed for the maximum pressure on the high pressure side of the pressure reducing valve. See also [1.3.2] and [2.9.1].

- The discharge capacity of the devices fitted on pipes for preventing overpressure is to be such that the pressure in these pipes cannot exceed the design pressure by more than 10%.

2.6 Flexible hoses and expansion joints

2.6.1 General

- The Society may permit the use of flexible hose assemblies (short lengths of hose normally with prefabricated end fittings ready for installation), for permanent connection between a fixed piping system and items of machinery, and expansion joints, both in metallic and non-metallic materials, provided they are approved for the intended service.
- Flexible hoses and expansion joints are to be of a type approved by the Society, designed in accordance with [2.6.2] and tested in accordance with [20.2.1].
- These requirements may also be applied to temporary connected flexible hoses or hoses of portable equipment, and media not indicated in d).
- Flexible hose assemblies as defined in a) may be accepted for use in fuel oil, lubricating, hydraulic and thermal oil systems, fresh water and sea water cooling systems, compressed air systems, bilge and ballast systems, and Class III steam systems. Flexible hoses in high pressure fuel oil injection systems are not accepted.
- Flexible hoses and expansion joints are to be installed in accordance with the requirements stated in [5.9.3].
- These requirements for flexible hose assemblies are not applicable to hoses intended to be used in fixed fire-extinguishing systems.

- g) Specific requirements are given in Part E, Chapter 1 for flexible hoses and expansion joints intended for cargo pipe lines of oil tankers.
- h) Flexible hoses and expansion joints intended for piping systems with a design temperature below the ambient temperature will be given special consideration by the Society.
- i) The position of flexible hoses and expansion joints is to be clearly shown on the piping drawings submitted to the Society.

2.6.2 Design of flexible hoses and expansion joints

- a) Flexible hoses and expansion joints are to be made of materials resistant to the marine environment and to the fluid they are to convey. Metallic materials are to comply with [2.1].
- b) Flexible hoses are to be designed and constructed in accordance with recognised national or international standards acceptable to the Society.
- c) Flexible hoses constructed of rubber materials and intended for use in bilge, ballast, compressed air, fuel oil, lubricating, hydraulic and thermal oil systems are to incorporate a single, double or more closely woven integral wire braid or other suitable material reinforcement.

Flexible hoses of plastics materials for the same purposes, such as Teflon or nylon, which are unable to be reinforced by incorporating closely woven integral wire braid are to have suitable material reinforcement as far as practicable.

- d) Where rubber or plastic material hoses are to be used in fuel oil and lubricating oil systems, the hoses are to have external wire braid protection in addition to the reinforcement mentioned above.
- e) Flexible hoses for use in steam systems are to be of metallic construction.
- f) Flexible hoses are to be complete with approved end fittings in accordance with the Manufacturer's specification. End connections that do not have a flange are to comply with [2.4.5] as applicable and each type of hose/fitting combination is to be subject to prototype testing to the same standard as that required by the hose with particular reference to pressure and impulse tests.
- g) The use of hose clamps and similar types of end attachments is not acceptable for flexible hoses in piping systems for steam, flammable media, starting air systems or for sea water systems where failure may result in flooding. In other piping systems, the use of hose clamps may be accepted where the working pressure is less than 0,5 MPa and provided there are double clamps at each end connection.
- h) Flexible hoses and expansion joints are to be so designed as to withstand the bursting pressure requested by the "Rules for the type approval of flexible hoses and expansion joints".
- i) Flexible hose assemblies and expansion joints intended for installation in piping systems where pressure pulses and/or high levels of vibration are expected to occur in

service are to be designed for the maximum expected impulse peak pressure and forces due to vibration. The tests required in [20.2.1] are to take into consideration the maximum anticipated in-service pressures, vibration frequencies and forces due to installation.

- j) Flexible hose assemblies and expansion joints constructed of non-metallic materials intended for installation in piping systems for flammable media and sea water systems where failure may result in flooding are to be of fire-resistant type, according to ISO 15540 and 15541.
- k) Flexible hose assemblies are to be selected for the intended location and application taking into consideration ambient conditions, compatibility with fluids under working pressure and temperature conditions consistent with the Manufacturer's instructions.

2.6.3 Conditions of use of expansion joints in sea water systems and within duct keels and tanks

- a) The use of non-metallic expansion joints on pipes connected to sea inlets and overboard discharges will be given special consideration by the Society. As a rule, the fitting of such joints between the ship side and the valves mentioned in [2.8.3] is not permitted. Furthermore, unless the above-mentioned valves are fitted with remote controls operable from places located above the freeboard deck, the expansion joints are to be arranged with guards which effectively enclose, but do not interfere with, the action of the expansion joints and reduce to the minimum practicable any flow of water into the machinery spaces in the event of failure of the flexible elements.
- b) Use of expansion joints in water lines for other services, including ballast lines in machinery spaces, in duct keels and inside double bottom water ballast tanks, and bilge lines inside double bottom tanks and deep tanks, will be given special consideration by the Society.

2.7 Valves and accessories

2.7.1 General

- a) Valves and accessories are normally to be built in accordance with a recognised standard.

Valves and fittings in piping systems are to be compatible with the pipes to which they are attached in respect of their strength (see [1.3.2] for design pressure) and are to be suitable for effective operation at the maximum working pressure they will experience in service.

Failing this, they are to be approved by the Society when they are fitted:

- in a class I piping system, or
 - in a class II piping system with a diameter exceeding 100 mm, or
 - on the ship side, on the collision bulkhead or on fuel tanks under static pressure.
- b) Shut-off valves are to be provided where necessary to isolate pumps, heat exchangers, pressure vessels, etc.,

from the rest of the piping system when necessary, and in particular:

- to allow the isolation of duplicate components without interrupting the fluid circulation
- for survey or repair purposes.

2.7.2 Design of valves and accessories

- a) Materials of valve and accessory bodies are to comply with the provisions of [2.1].
- b) Connections of valves and accessories with pipes are to comply with the provisions of [2.4].
- c) All valves and accessories are to be so designed as to prevent the loosening of covers and glands when they are operated.
- d) Valves are to be so designed as to shut with a right-hand (clockwise) motion of the wheels.
- e) Valves are to be provided with local indicators showing whether they are open or shut, unless this is readily apparent.

2.7.3 Valves with remote control

- a) All valves which are provided with remote control are also to be designed for local manual operation.
- b) The remote control system and means of local operation are to be independent. In this respect, arrangement of the local operation by means of a fixed hand pump will be specially considered by the Society.
- c) In the case of valves which are to be provided with remote control in accordance with the Rules, opening and/or closing of the valves by local manual means is not to render the remote control system inoperable.
- d) Power failure of the remote control system is not to cause an undesired change of the valve position.

2.8 Sea inlets and overboard discharges

2.8.1 General

Except where expressly stated in Article [8], the requirements of this sub-article do not apply to scuppers and sanitary discharges.

2.8.2 Design of sea inlets and overboard discharges

- a) All inlets and discharges in the shell plating are to be fitted with efficient and accessible arrangements for preventing the accidental admission of water into the ship.
- b) Sea inlets and overboard discharges are to be fitted with valves complying with [2.7] and [2.8.3].
- c) Machinery space main and auxiliary sea inlets and discharges in connection with the operation of machinery are to be fitted with readily accessible valves between the pipes and the shell plating or between the pipes and fabricated boxes attached to the shell plating. The valves

may be controlled locally and are to be provided with indicators showing whether they are open or closed.

- d) Sea inlets are to be so designed and arranged as to limit turbulence and to avoid the admission of air due to motion of the ship.
- e) Sea inlets are to be fitted with gratings complying with [2.8.4].
- f) Provisions are to be made for clearing sea inlet gratings.
- g) Sea chests are to be suitably protected against corrosion.

2.8.3 Sea inlets

Cooling water systems for machinery that are essential for the propulsion and safety of the ship, including sea chests inlets, are to be designed for the environmental conditions applicable to the ice class IC [Part F, Chapter 6].

Except if differently provided by the requirements of the notation **POLAR CLASS** [Part F, Chapter 7] (when applicable), one ice box located preferably near centre line is to be arranged, with a calculated volume at least 1m³ for every 750 kW of the total installed power.

Ice boxes are to be designed for an effective separation of ice and venting of air.

Sea inlet valves are to be secured directly to the ice boxes. The valve is to be of a full bore type.

Ice boxes and sea bays are to have vent pipes and are to have shut off valves connected direct to the shell.

Means are to be provided to prevent freezing of sea bays, ice boxes, ship side valves and fittings above the load water line.

Efficient means are to be provided to re-circulate cooling seawater to the ice box. Total sectional area of the circulating pipes is not to be less than the area of the cooling water discharge pipe.

Detachable gratings or manholes are to be provided for ice boxes. Manholes are to be located above the deepest load line. Access is to be provided to the ice box from above.

Openings in ship sides for ice boxes are to be fitted with gratings, or holes or slots in shell plates. The net area through these openings is to be not less than 5 times the area of the inlet pipe. The diameter of holes and width of slot in shell plating is to be not less than 20 mm. Gratings of the ice boxes are to be provided with a means of clearing. Clearing pipes are to be provided with screw-down type non-return valves.

2.8.4 Valves

- a) Sea inlet and overboard discharge valves are to be secured:
 - directly on the shell plating, or
 - on sea chests built on the shell plating, with scantlings in compliance with Part B, or
 - on extra-reinforced and short distance pieces attached to the shell (see Tab 5).
- b) The bodies of the valves and distance pieces are to have a spigot passing through the plating without projecting beyond the external surface of such plating or of the doubling plates and stiffening rings, if any.

- c) Valves are to be secured by means of:
- bolts screwed through the plating with a counter-sunk head, or
 - studs screwed in heavy pads themselves secured to the hull or chest plating, without penetration of the plating by the stud holes.
- d) The use of butterfly valves will be specially considered by the Society. In any event, butterfly valves not fitted with flanges are not to be used for water inlets or overboard discharges unless provisions are made to allow disassembling at sea of the pipes served by these valves without any risk of flooding.
- e) The materials of the valve bodies and connecting pieces are to comply with [2.1.2] Tab 4.
- f) Ship side valves serving piping systems made of plastics are to comply with App 3, [3.7.1].

2.8.5 Gratings

- a) Gratings are to have a free flow area not less than twice the total section of the pipes connected to the inlet.
- b) When gratings are secured by means of screws with a countersunk head, the tapped holes provided for such screws are not to pass through the plating or doubling plates outside distance pieces or chests.
- c) Screws used for fixing gratings are not to be located in the corners of openings in the hull or of doubling plates.
- d) In the case of large sea inlets, the screws used for fixing the gratings are to be locked and protected from corrosion.
- e) When gratings are cleared by use of compressed air or steam devices, the chests, distance pieces and valves of sea inlets and outlets thus arranged are to be so constructed as to withstand the maximum pressure to which they may be subjected when such devices are operating.

2.8.6 Ship side connections for blow-down of boilers

- a) Blow-down pipes of boilers are to be provided with cocks or valves placed as near the end of the pipes as possible, while remaining readily accessible and located above the engine room floor.
- b) Blow-down valves are to be so designed that it is easy to ascertain whether they are open or shut. Where cocks are used, the control keys are to be such that they cannot be taken off unless the cocks are shut. Where valves are used, the control-wheels are to be permanently fixed to the spindle.
- c) A protection ring is to be fitted on the shell plating, outside, at the end of the blow-down pipes. The spigot of the valve referred to in [2.8.3], item b), is to pass through this ring.

2.9 Control and monitoring

2.9.1 General

- a) Local indicators are to be provided for at least the following parameters:
- pressure, in pressure vessels, at pump or compressor discharge, at the inlet of the equipment served, on the low pressure side of pressure reducing valves
 - temperatures, in tanks and vessels, at heat exchanger inlet and outlet
 - levels, in tanks and vessels containing liquids.
- b) Safeguards are to be provided where an automatic action is necessary to restore acceptable values for a faulty parameter.
- c) Automatic controls are to be provided where it is necessary to maintain parameters related to piping systems at a pre-set value.

2.9.2 Level gauges

Level gauges used in fuel oil systems, pressure lubricating oil systems and other flammable oil systems are to be of a type approved by the Society and are subject to the following conditions:

- in cargo ships, their failure or overfilling of the tank is not to permit release of fuel into the space. The use of cylindrical gauges is prohibited. The Society may permit the use of oil-level gauges with flat glasses and self-closing valves between the gauges and fuel tanks. Their glasses are to be made of heat-resistant material and efficiently protected against shocks.

The above level gauges are to be maintained in the proper condition to ensure their continued accurate functioning in service.

Note 1: On cargo ships of less than 500 tons gross tonnage and non-propelled ships:

- cylindrical gauges may be used provided they are fitted with self-closing valves at their lower end as well as at their upper end if the latter is below the maximum liquid level.
- in the case of tanks not subject to filling by power pumps, with the exception of fuel oil service tanks, the valves need not be of the self-closing type. Such valves are, however, to be readily accessible and instruction plates are to be fitted adjacent to them specifying that they are to be kept closed.

3 Welding of steel piping

3.1 Application

3.1.1

- a) The following requirements apply to welded joints belonging to class I or II piping systems.
They may also be applied to class III piping systems, at the discretion of the Society.
- b) This article does not apply to refrigerated cargo installation piping systems operating at temperatures lower than minus 40°C.
- c) The requirements for qualification of welding procedures are given in Part D.

3.2 General

3.2.1 Welding processes

- Welded joints of pipes are to be made by means of electric arc or oxyacetylene welding, or any other previously approved process.
- When the design pressure exceeds 0,7 MPa, oxyacetylene welding is not permitted for pipes with an external diameter greater than 100 mm or a thickness exceeding 6 mm.

3.2.2 Location of joints

The location of welded joints is to be such that as many as possible can be made in a workshop. The location of welded joints to be made on board is to be so determined as to permit their joining and inspection in satisfactory conditions.

3.3 Design of welded joints

3.3.1 Types of joints

- Except for the fixing of flanges on pipes in the cases mentioned in [2.4.4], Fig 1 and for the fixing of branch pipes, joints between pipes and between pipes and fittings are to be of the butt-welded type. However, for class I pipes with an internal diameter not exceeding 50 mm and for class II pipes, socket welded connections of approved types may be used.
- For butt-welded joints between pipes or between pipes and flanges or other fittings, correctly adjusted backing rings may be used; such rings are to be either of the same grade of steel as the elements to be welded or of such a grade as not to adversely influence the weld; if the backing ring cannot be removed after welding, it is to be correctly profiled.

3.3.2 Assembly of pipes of unequal thickness

If the difference of thickness between pipes to be butt-welded exceeds 10% of the thickness of the thinner pipe plus 1 mm, subject to a maximum of 4 mm, the thicker pipe is to be thinned down to the thickness of the thinner pipe on a length at least equal to 4 times the offset, including the width of the weld if so desired.

3.3.3 Accessories

- When accessories such as valves are connected by welding to pipes, they are to be provided with necks of sufficient length to prevent abnormal deformations during the execution of welding or heat treatment.
- For the fixing by welding of branch pipes on pipes, it is necessary to provide either a thickness increase as indicated in [2.2.5] or a reinforcement by doubling plate or equivalent.

3.4 Preparation of elements to be welded and execution of welding

3.4.1 General

Attention is drawn to the provisions of Sec 3, which apply to the welding of pressure pipes.

3.4.2 Edge preparation for welded joints

The preparation of the edges is preferably to be carried out by mechanical means. When flame cutting is used, care is to be taken to remove the oxide scales and any notch due to irregular cutting by matching, grinding or chipping back to sound metal.

3.4.3 Abutting of parts to be welded

- The elements to be welded are to be so abutted that surface misalignments are as small as possible.
- As a general rule, for elements which are butt-welded without a backing ring the misalignment between internal walls is not to exceed the lesser of:
 - the value given in Tab 18 as a function of thickness t and internal diameter d of these elements, and
 - $t/4$.

Where necessary, the pipe ends are to be bored or slightly expanded so as to comply with these values; the thickness obtained is not to be less than the Rule thickness.

- In the case of welding with a backing ring, smaller values of misalignment are to be obtained so that the space between the backing ring and the internal walls of the two elements to be assembled is as small as possible; normally this space is not to exceed 0,5 mm.
- The elements to be welded are to be adequately secured so as to prevent modifications of their relative position and deformations during welding.
- Tack welds should be made with an electrode suitable for the base metal; tack welds which form part of the finished weld should be made using approved procedures. When welding materials requiring preheating are employed, the same preheating should be applied during tack welding.

Table 18 : Maximum value of misalignment

d (mm)	t (mm)		
	$t \leq 6$	$6 < t \leq 10$	$10 < t$
$d < 150$	1,0	1,0	1,0
$150 \leq d < 300$	1,0	1,5	1,5
$300 \leq d$	1,0	1,5	2,0

3.4.4 Protection against adverse weather conditions

- Pressure pipes are to be welded, both on board and in the shop, away from draughts and sudden temperature variations.
- Unless special justification is given, no welding is to be performed if the temperature of the base metal is lower than 0°C.

3.4.5 Preheating

- Preheating is to be performed as indicated in Tab 19, depending on the type of steel, the chemical composition and the pipe thickness.
- The temperatures given in Tab 19 are based on the use of low hydrogen processes. Where low hydrogen pro-

cesses are not used, the Society reserves the right to require higher preheating temperatures.

3.5 Post-weld heat treatment

3.5.1 General

- a) As far as practicable, the heat treatment is to be carried out in a furnace. Where this is impracticable, and more particularly in the case of welding on board, the treatment is to be performed locally by heating uniformly a circular strip, extending on at least 75 mm on both sides of the welded joint; all precautions are to be taken to permit accurate checking of the temperature and slow cooling after treatment.
- b) For austenitic and austenitic ferritic steels, post-weld heat treatment is generally not required.

Table 19 : Preheating temperature

Type of steel		Thickness of thicker part (mm)	Minimum preheating temperature (°C)
C and C-Mn steels	$C + \frac{Mn}{6} \leq 0,40$	$t \geq 20$ (2)	50
	$C + \frac{Mn}{6} > 0,40$	$t \geq 20$ (2)	100
0,3 Mo		$t \geq 13$ (2)	100
1 Cr 0,5 Mo		$t < 13$	100
		$t \geq 13$	150
2,25 Cr 1 Mo (1)		$t < 13$	150
		$t \geq 13$	200
0,5 Cr 0,5 Mo 0,25 V (1)		$t < 13$	150
		$t \geq 13$	200
<p>(1) For 2,25 Cr 1 Mo and 0,5 Cr 0,5 Mo 0,25 V grades with thicknesses up to 6 mm, preheating may be omitted if the results of hardness tests carried out on welding procedure qualification are considered acceptable by the Society.</p> <p>(2) For welding in ambient temperature below 0°C, the minimum preheating temperature is required independent of the thickness unless specially approved by the Society.</p>			

3.5.2 Heat treatment after welding other than oxyacetylene welding

- a) Stress relieving heat treatment after welding other than oxyacetylene welding is to be performed as indicated in Tab 20, depending on the type of steel and thickness of the pipes.
- b) The stress relieving heat treatment is to consist in heating slowly and uniformly to a temperature within the range indicated in the Table, soaking at this temperature

for a suitable period, normally one hour per 25 mm of thickness with a minimum of half an hour, cooling slowly and uniformly in the furnace to a temperature not exceeding 400°C and subsequently cooling in still atmosphere.

- c) In any event, the heat treatment temperature is not to be higher than $(T_T - 20)^\circ\text{C}$, where T_T is the temperature of the final tempering treatment of the material

Table 20 : Heat treatment temperature

Type of steel	Thickness of thicker part (mm)	Stress relief treatment temperature (°C)
C and C-Mn steels	$t \geq 15$ (1) (3)	550 to 620
0,3 Mo	$t \geq 15$ (1)	580 to 640
1 Cr 0,5 Mo	$t \geq 8$	620 to 680
2,25 Cr 1 Mo 0,5 Cr 0,5 Mo 0,25 V	any (2)	650 to 720
<p>(1) Where steels with specified Charpy V notch impact properties at low temperature are used, the thickness above which post-weld heat treatment is to be applied may be increased, subject to the special agreement of the Society.</p> <p>(2) For 2,25Cr 1Mo and 0,5Cr 0,5Mo 0,25 V grade steels, heat treatment may be omitted for pipes having thickness lower than 8 mm, diameter not exceeding 100 mm and service temperature not exceeding 450°C.</p> <p>(3) For C and C-Mn steels, stress relieving heat treatment may be omitted up to 30 mm thickness, subject to the special agreement of the Society.</p>		

3.5.3 Heat treatment after oxyacetylene welding

Stress relieving heat treatment after oxyacetylene welding is to be performed as indicated in Tab 21, depending on the type of steel.

3.6 Inspection of welded joints

3.6.1 General

- a) The inspection of pressure pipe welded joints is to be performed at the various stages of the fabrication further to the qualifications defined in [3.1.1], item c).
- b) The examination mainly concerns those parts to be welded further to their preparation, the welded joints once they have been made and the conditions for carrying out possible heat treatments.
- c) The required examinations are to be carried out by qualified operators in accordance with procedures and techniques to the Surveyor's satisfaction.

Table 21 : Heat treatment after oxyacetylene welding

Type of steel	Heat treatment and temperature (°C)
C and C-Mn	Normalising 880 to 940
0,3 Mo	Normalising 900 to 940
1Cr-0,5Mo	Normalising 900 to 960 Tempering 640 to 720
2,25Cr-1Mo	Normalising 900 to 960 Tempering 650 to 780
0,5Cr-0,5Mo-0,25V	Normalising 930 to 980 Tempering 670 to 720

3.6.2 Visual examination

Welded joints, including the inside wherever possible, are to be visually examined.

3.6.3 Non-destructive examinations

a) Non-destructive tests for class I pipes are to be performed as follows:

- butt-welded joints of pipes with an external diameter exceeding 75 mm are to be subjected to full radiographic examination or equivalent
- welded joints other than butt-welded joints and which cannot be radiographed are to be examined by magnetic particle or liquid penetrant tests
- fillet welds of flange connections are to be examined by magnetic particle tests or by other appropriate non-destructive tests.

b) Non-destructive tests for class II pipes are to be performed as follows:

- butt-welded joints of pipes with an external diameter exceeding 100 mm are to be subjected to at least 10% random radiographic examination or equivalent
- welded joints other than butt-welded joints are to be examined by magnetic particle tests or by other appropriate non-destructive tests
- fillet welds of flange connections may be required to be examined by magnetic particle tests or by other appropriate non-destructive tests, at the discretion of the Surveyor.

3.6.4 Defects and acceptance criteria

a) Joints for which non-destructive examinations reveal unacceptable defects are to be re-welded and subsequently to undergo a new non-destructive examination. The Surveyor may require that the number of joints to be subjected to non-destructive examination is larger than that resulting from the provisions of [3.6.3].

b) The acceptance criteria of defects are:

- for class I pipes, those defined in the "Rules for carrying out not-destructive examinations of welding" for the special quality level,
- for class II pipes, those defined in the "Rules for carrying out not-destructive examinations of welding" for the normal quality level.

4 Bending of pipes

4.1 Application

4.1.1 This Article applies to pipes made of:

- alloy or non-alloy steels,
- copper and copper alloys.

4.2 Bending process

4.2.1 General

The bending process is to be such as not to have a detrimental influence on the characteristics of the materials or on the strength of the pipes.

4.2.2 Bending radius

Unless otherwise justified, the bending radius measured on the centreline of the pipe is not to be less than:

- twice the external diameter for copper and copper alloy pipes,
- 3 times the external diameter for cold bent steel pipes.

4.2.3 Acceptance criteria

- a) The pipes are to be bent in such a way that, in each transverse section, the difference between the maximum and minimum diameters after bending does not exceed 10% of the mean diameter; higher values, but not exceeding 15%, may be allowed in the case of pipes which are not subjected in service to appreciable bending stresses due to thermal expansion or contraction.
- b) The bending is to be such that the depth of the corrugations is as small as possible and does not exceed 5% of their length.

4.2.4 Hot bending

- a) In the case of hot bending, all arrangements are to be made to permit careful checking of the metal temperature and to prevent rapid cooling, especially for alloy steels.
- b) Hot bending is to be generally carried out in the temperature range 850°C-1000°C for all steel grades; however, a decreased temperature down to 750°C may be accepted during the forming process.

4.3 Heat treatment after bending

4.3.1 Copper and copper alloy

Copper and copper alloy pipes are to be suitably annealed after cold bending if their external diameter exceeds 50 mm.

4.3.2 Steel

- a) After hot bending carried out within the temperature range specified in [4.2.4], the following applies:
 - for C, C-Mn and C-Mo steels, no subsequent heat treatment is required,
 - for Cr-Mo and Cr-Mo-V steels, a subsequent stress relieving heat treatment in accordance with Tab 20 is required.
- b) After hot bending performed outside the temperature range specified in [4.2.4], a subsequent new heat treatment in accordance with Tab 21 is required for all grades.
- c) After cold bending at a radius lower than 4 times the external diameter of the pipe, a heat treatment in accordance with Tab 21 is required.

5 Arrangement and installation of piping systems

5.1 General

5.1.1 Unless otherwise specified, piping and pumping systems covered by the Rules are to be permanently fixed on board ship.

5.2 Location of tanks and piping system components

5.2.1 Flammable oil systems

Location of tanks and piping system components conveying flammable fluids under pressure is to comply with [5.10].

5.2.2 Piping systems with open ends

Attention is to be paid to the requirements for the location of open-ended pipes on board ships having to comply with the provisions of [5.5].

5.2.3 Pipe lines located inside tanks

- a) The passage of pipes through tanks, when permitted, requires special arrangements such as reinforced thickness as per Tab 5 for steel pipes or tunnels, in particular for:
 - bilge pipes
 - ballast pipes
 - scuppers and sanitary discharges
 - air, sounding and overflow pipes
 - fuel oil pipes.
- b) Junctions of pipes inside tanks are to be made by welding or welded reinforced flange connections. See also [2.4.3].

5.2.4 Overboard discharges

Overboard discharges are to be so located as to prevent any discharge of water into the lifeboats while they are being lowered.

5.2.5 Piping and electrical apparatus

The installation of piping near switchboards and other electrical apparatus is to comply with Ch 2, Sec 12, [6.1.7].

5.3 Passage through watertight bulkheads or decks

5.3.1 Penetration of watertight bulkheads and decks

- a) Where penetrations of watertight bulkheads and internal decks are necessary for piping and ventilation, arrangements are to be made to maintain the watertight integrity.
- b) Lead or other heat sensitive materials are not to be used in piping systems which penetrate watertight subdivision bulkheads or decks, where deterioration of such systems in the event of fire would impair the watertight integrity of the bulkhead or decks.

This applies in particular to the following systems:

- bilge system
 - ballast system
 - scuppers and sanitary discharge systems.
- c) Where bolted connections are used for piping passing through watertight bulkheads or decks, the bolts are to be screwed in heavy pads secured to the bulkhead or deck plating without penetration of the plating by the bolt holes. Where welded connections are used, they are to be welded on both sides of the bulkhead or deck plating.
 - d) Penetrations of watertight bulkheads or decks by plastic pipes are to comply with App 3, [3.6.2].

5.3.2 Passage through the collision bulkhead

- a) The collision bulkhead may be pierced below the bulkhead deck by not more than one pipe for dealing with fluid in the forepeak tank, provided that the pipe is fitted with a screw-down valve capable of being operated from above the bulkhead deck, the valve chest being secured inside the forepeak to the collision bulkhead. The Society may, however, authorise the fitting of this valve on the after side of the collision bulkhead provided that the valve is readily accessible under all service conditions and the space in which it is located is not a cargo space.

All valves are to be of steel, bronze or other approved ductile material. Valves of ordinary cast iron or similar material are not acceptable.

- b) If the forepeak is divided to hold two different kinds of liquids the Society may allow the collision bulkhead to be pierced below the bulkhead deck by two pipes, each of which is fitted as required in a), provided the Society is satisfied that there is no practical alternative to the fitting of such a second pipe and that, having regard to the additional subdivision provided in the forepeak, the safety of the ship is maintained.
- c) The remote operation device of the valve referred to in a) is to include an indicator to show whether the valve is open or shut.

5.4 Independence of lines

5.4.1 As a general rule, bilge and ballast lines are to be entirely independent and distinct from lines conveying liquid cargo, lubricating oil and fuel oil, with the exception of:

- pipes located between collecting boxes and pump suction
- pipes located between pumps and overboard discharges
- pipes supplying compartments likely to be used alternatively for ballast, fuel oil or liquid or dry cargoes, provided such pipes are fitted with blind flanges or other appropriate change-over devices, in order to avoid any mishandling.

5.5 Prevention of progressive flooding

5.5.1 Principle

- a) In order to comply with the subdivision and damage stability requirements of Pt F, Ch 10, Sec 11, provision is to be made to prevent any progressive flooding of a dry compartment served by any open-ended pipe, in the event that such pipe is damaged or broken in any other compartment by collision or grounding.
- b) For this purpose, if pipes are situated within assumed flooded compartments, arrangements are to be made to ensure that progressive flooding cannot thereby extend to compartments other than those assumed to be flooded for each case of damage. However, the Society may permit minor progressive flooding if it is demonstrated that its effects can be easily controlled and the safety of the ship is not impaired. Refer to Pt F, Ch 10, Sec 11.

5.5.2 Extent of damage

For the definition of the assumed transverse extent of damage, reference is to be made to Pt F, Ch 10, Sec 11.

5.5.3 Piping arrangement

- a) The assumed transverse extent of damage is not to contain any pipe with an open end in a compartment located outside this extent.
- b) Where the provisions of a) cannot be fulfilled, and after special examination by the Society, pipes may be situated within the assumed transverse extent of damage penetration provided that:
 - either a closable valve operable from above the bulkhead deck is fitted at each penetration of a watertight subdivision and secured directly on the bulkhead, or
 - a closable valve operable from above the bulkhead deck is fitted at each end of the pipe concerned, the valves and their control system being inboard of the assumed extent of damage, or
 - the tanks to which the pipe concerned leads are regarded in the damage stability calculations as being flooded when damage occurs in a compartment through which the pipe passes.

- c) Valves required to be operable from above the bulkhead deck are to be fitted with an indicator to show whether the valve is open or shut.

Where the valve is remote controlled by other than mechanical means, and where the remote control system is located, even partly, within the assumed extent of damage penetration, this system is to be such that the valve is automatically closed by loss of power.

- d) Air and overflow pipes are to be so arranged as to prevent the possibility of flooding of other tanks in other watertight compartments in the event of any one tank being flooded.

This arrangement is to be such that in the range of positive residual righting levers beyond the angle of equilibrium stage of flooding, the progressive flooding of tanks or watertight compartments other than that flooded does not occur.

5.6 Provision for expansion

5.6.1 General

Piping systems are to be so designed and pipes so fixed as to allow for relative movement between pipes and the ship's structure, having due regard to:

- the temperature of the fluid conveyed
- the coefficient of thermal expansion of the pipes material
- the deformation of the ship's hull.

5.6.2 Fitting of expansion devices

All pipes subject to thermal expansion and those which, due to their length, may be affected by deformation of the hull, are to be fitted with expansion pieces or loops.

5.7 Supporting of the pipes

5.7.1 General

Unless otherwise specified, the fluid lines referred to in this Section are to consist of pipes connected to the ship's structure by means of collars or similar devices.

5.7.2 Arrangement of supports

Shipyards are to take care that :

- a) The arrangement of supports and collars is to be such that pipes and flanges are not subjected to abnormal bending stresses, taking into account their own mass, the metal they are made of, and the nature and characteristics of the fluid they convey, as well as the contractions and expansions to which they are subjected.
- b) Heavy components in the piping system, such as valves, are to be independently supported.

5.8 Protection of pipes

5.8.1 Protection against shocks

Pipes passing through cargo holds and 'tweendecks are to be protected against shocks by means of strong casings.

5.8.2 Protection against corrosion and erosion

- a) Pipes are to be efficiently protected against corrosion, particularly in their most exposed parts, either by selec-

tion of their constituent materials, or by an appropriate coating or treatment.

- b) The layout and arrangement of sea water pipes are to be such as to prevent sharp bends and abrupt changes in section as well as zones where water may stagnate. The inner surface of pipes is to be as smooth as possible, especially in way of joints. Where pipes are protected against corrosion by means of galvanising or other inner coating, arrangements are to be made so that this coating is continuous, as far as possible, in particular in way of joints.
- c) If galvanised steel pipes are used for sea water systems, the water velocity is not to exceed 3 m/s.
- d) If copper pipes are used for sea water systems, the water velocity is not to exceed 2 m/s.
- e) Arrangements are to be made to avoid galvanic corrosion.

5.8.3 Protection against frosting

Pipes are to be adequately insulated against cold wherever deemed necessary to prevent frost.

This applies specifically to pipes passing through refrigerated spaces and which are not intended to ensure the refrigeration of such spaces.

5.8.4 Protection of high temperature pipes and components

- a) All pipes and other components where the temperature may exceed 220°C are to be efficiently insulated, as indicated in Sec 1, [3.11].
- b) Particular attention is to be paid to lagging in way of flanges.

5.9 Valves, accessories and fittings

5.9.1 General

Cocks, valves and other accessories are generally to be arranged so that they are easily visible and accessible for manoeuvring, control and maintenance. They are to be installed in such a way as to operate properly.

5.9.2 Valves and accessories

- a) In machinery spaces and tunnels, the cocks, valves and other accessories of the fluid lines referred to in this Section are to be placed:
 - above the floor,
 - or, when this is not possible, immediately under the floor, provided provision is made for their easy access and control in service.
- b) Control-wheels of low inlet valves are to rise at least 0,45 m above the lowest floor.

5.9.3 Flexible hoses and expansion joints

- a) Flexible hoses are to be so arranged as to be clearly visible and readily accessible at all times.
- b) In general, flexible hoses and expansion joints are to be limited to a length necessary to provide for relative

movement between fixed and flexibly mounted items of machinery/equipment or systems.

- c) Flexible hose assemblies and expansion joints are not to be installed where they may be subjected to torsion deformation (twisting) under normal operating conditions.
- d) The adjoining pipes are to be suitably aligned, supported, guided and anchored.
- e) The number of flexible hoses and expansion joints is to be kept to a minimum.
- f) Where flexible hoses and expansion joints are intended to be used in piping systems conveying flammable fluids that are in close proximity to heated surfaces, the risk of ignition due to failure of the hose assembly and subsequent release of fluids is to be mitigated as far as practicable by the use of screens or other similar protection to the satisfaction of the Society.
- g) Expansion joints are to be protected against over-extension and over-compression.
- h) The installation of flexible hose assemblies and expansion joints is to be in accordance with the Manufacturer's instructions and use limitations with particular attention to the following, as applicable:
 - orientation
 - end connection support (where necessary)
 - avoidance of hose contact that could cause rubbing and abrasion
 - minimum bend radii.

5.9.4 Thermometers

Thermometers and other temperature-detecting elements in fluid systems under pressure are to be provided with pockets built and secured so that the thermometers and detecting elements can be removed while keeping the piping under pressure.

5.9.5 Pressure gauges

Pressure gauges and other similar instruments are to be fitted with an isolating valve or cock at the connection with the main pipe.

5.9.6 Nameplates

- a) Accessories such as cocks and valves on the fluid lines referred to in this Section are to be provided with nameplates indicating the apparatus and lines they serve except where, due to their location on board, there is no doubt as to their purpose.
- b) Nameplates are to be fitted at the upper part of air and sounding pipes.

5.10 Additional arrangements for flammable fluids

5.10.1 General

The requirements in [5.10.3] and [5.10.4] apply to:

- fuel oil systems, in all spaces
- lubricating oil systems, in machinery spaces
- other flammable oil systems, in locations where means of ignition are present.

5.10.2 Prohibition of carriage of flammable oils in forepeak tanks

In cargo ships of more than 400 tons gross tonnage, fuel oil, lubricating oil and other flammable oils are not to be carried in forepeak tanks or tanks forward of the collision bulkhead.

5.10.3 Prevention of flammable oil leakage ignition

- a) As far as practicable, parts of the fuel oil and lubricating oil systems containing heated oil under pressure exceeding 0,18 MPa are to be placed above the platform or in any other position where defects and leakage can readily be observed.

The machinery spaces in way of such parts are to be adequately illuminated.

- b) No flammable oil tanks are to be situated where spillage or leakage therefrom can constitute a hazard by falling on:

- hot surfaces, including those of boilers, heaters, steam pipes, exhaust manifolds and silencers
- electrical equipment
- air intakes
- other sources of ignition.

- c) Parts of flammable oil systems under pressure exceeding 0,18 MPa such as pumps, filters and heaters are to comply with the provisions of b) above.

- d) Flammable oil lines are not to be located immediately above or near units of high temperature including boilers, steam pipelines, exhaust manifolds, silencers or other equipment required to be insulated in Sec 1, [3.11.1]. As far as practicable, flammable oil lines are to be arranged far from hot surfaces, electrical installations or other sources of ignition and to be screened or otherwise suitably protected to avoid oil spray or oil leakage onto the sources of ignition.

Precautions are to be taken to prevent any oil that may escape under pressure from any pump, filter or heater from coming into contact with heated surfaces.

- e) Any relief valve of fuel oil and lubricating oil systems is to discharge to a safe position, such as an appropriate tank. See also item (a) of [9.1.7].

5.10.4 Provisions for flammable oil leakage containment

- a) Tanks used for the storage of flammable oils together with their fittings are to be so arranged as to prevent spillages due to leakage or overfilling.

- b) Drip trays with adequate drainage to contain possible leakage from flammable fluid systems are to be fitted:
- under independent tanks (refer to App 4, [2.3.2])
 - under burners
 - under purifiers and any other oil processing equipment
 - under pumps, heat exchangers and filters
 - under valves and all accessories subject to oil leakage
 - surrounding internal combustion engines.
- c) The coaming height of drip trays is to suit the amount of potential oil spillage.
- d) Where drain pipes are provided for collecting leakages, they are to be led to an appropriate drain tank.

5.10.5 Drain tank

- a) The drain tank is not to form part of an overflow system and is to be fitted with an overflow alarm device.
- b) In ships required to be fitted with a double bottom, appropriate precautions are to be taken when the drain tank is constructed in the double bottom, in order to avoid flooding of the machinery space where drip trays are located, in the event of accidentally running aground.

5.10.6 Valves

All valves and cocks forming part of flammable oil systems are to be capable of being operated from readily accessible positions and, in machinery spaces, from above the working platform.

5.10.7 Level switches

Level switches fitted to flammable oil tanks are to be contained in a steel or other fire-resisting enclosure.

6 Bilge systems

6.1 Application

6.1.1 This Article does not apply to bilge systems of non-propelled ships. See Pt E, Ch 10, Sec 8.

6.2 Principle

6.2.1 General

An efficient bilge pumping system shall be provided, capable of pumping from and draining any watertight compartment other than a space permanently appropriated for the carriage of fresh water, water ballast, fuel oil or liquid cargo and for which other efficient means of pumping are to be provided, under all practical conditions. Efficient means shall be provided for draining water from insulated holds.

Bilge pumping system is not intended at coping with water ingress resulting from structural or main sea water piping damage.

6.2.2 Availability of the bilge system

The bilge system is to be able to work while the other essential installations of the ship, especially the fire-fighting installations, are in service.

6.2.3 Bilge and ballast systems

The arrangement of the bilge and ballast pumping system shall be such as to prevent the possibility of water passing from the sea and from water ballast spaces into the cargo and machinery spaces, or from one compartment to another.

Provisions shall be made to prevent any deep tank having bilge and ballast connections being inadvertently flooded from the sea when containing cargo, or being discharged through a bilge pump when containing water ballast.

6.3 Design of bilge systems

6.3.1 General

- a) The bilge pumping system is to consist of pumps connected to a bilge main line so arranged as to allow the draining of all spaces mentioned in [6.2.1] through bilge branches, distribution boxes and bilge suction, except for some small spaces where individual suction by means of hand pumps may be accepted as stated in [6.6.3] and [6.6.4].
- b) If deemed acceptable by the Society, bilge pumping arrangements may be dispensed with in specific compartments provided the safety of the ship is not impaired.

6.3.2 Number and distribution of bilge suction

- a) Draining of watertight spaces is to be possible, when the ship is on an even keel and either is upright or has a list of up to 5°, by means of at least:
 - two suction in machinery spaces, including one branch bilge suction and one direct suction and, in addition, for spaces containing propulsion machinery, one emergency bilge suction
 - one suction in other spaces.
 See also [6.5.5].
- b) Bilge suction are to be arranged as follows:
 - wing suction are generally to be provided except in the case of short and narrow compartments when a single suction ensures effective draining in the above conditions
 - in the case of compartments of unusual form, additional suction may be required to ensure effective draining under the conditions mentioned in [6.3.2], item a).
- c) In all cases, arrangements are to be made such as to allow a free and easy flow of water to bilge suction.

6.3.3 Prevention of communication between spaces - Independence of the lines

- a) Bilge lines are to be so arranged as to avoid inadvertent flooding of any dry compartment.
- b) Bilge lines are to be entirely independent and distinct from other lines except where permitted in [5.4].
- c) In ships designed for the carriage of flammable or toxic liquids in enclosed cargo spaces, the bilge pumping system is to be designed to prevent the inadvertent pumping of such liquids through machinery space piping or pumps.

6.4 Draining of cargo spaces

6.4.1 General

- a) Cargo holds are to be fitted with bilge suction connected to the bilge main.
- b) Drainage arrangements for cargo holds likely to be used alternatively for ballast, fuel oil or liquid or dry cargoes are to comply with [7.1].

6.4.2 Ships without double bottom

- a) In ships without double bottom, bilge suction are to be provided in the holds:
 - at the aft end in the centreline where the rise of floor exceeds 5°,
 - at the aft end on each side in other cases.
- b) Additional suction may be required if, due to the particular shape of the floor, the water within the compartment cannot be entirely drained by means of the suction mentioned in a) above.

6.4.3 Ships with double bottom

- a) In ships with double bottom, bilge suction are to be provided in the holds on each side aft.

Where the double bottom plating extends from side to side, the bilge suction are to be led to wells located at the wings.

Where the double bottom plating slopes down to the centreline by more than 5°, only one centreline well with a suction may be accepted.
- b) If the inner bottom is of a particular design, shows discontinuity or is provided with longitudinal wells, the number and position of bilge suction will be given special consideration by the Society.

6.4.4 Ships with holds over 30 m in length

In holds greater than 30 m in length, bilge suction are to be provided in the fore and aft ends.

6.4.5 Additional suction

Additional suction may be required in the forward part of holds in ships which are likely to navigate normally with a trim by the head.

6.5 Draining of machinery spaces

6.5.1 General

Where all the propulsion machinery, boilers and main auxiliaries are located in a single watertight space, the bilge suction are to be distributed and arranged in accordance with the provisions of [6.5.5].

6.5.2 Branch bilge suction

The branch bilge suction is to be connected to the bilge main.

6.5.3 Direct suction

The direct suction is to be led direct to an independent power bilge pump and so arranged that it can be used independently of the main bilge line.

The use of ejectors for pumping through the direct suction will be given special consideration.

6.5.4 Emergency bilge suction

- a) The emergency bilge suction is to be led directly from the drainage level of the machinery space to a main circulating (or cooling) pump and fitted with a non-return valve.
- b) In ships where, in the opinion of the Society, the main circulating (or cooling) pump is not suitable for this purpose, the emergency bilge suction is to be led from the largest available independent power driven pump to the drainage level of the machinery space. Such a pump is not to be a bilge pump. Its capacity when the emergency suction is operating is to be at least equal to the required capacity of each bilge pump as determined in [6.7.4].
- c) The emergency bilge suction is to be located at the lowest possible level in the machinery spaces.

6.5.5 Number and distribution of suction in propulsion machinery spaces

- a) In propulsion machinery spaces, bilge suction are to include:
 - where the bottom of the space, bottom plating or top of the double bottom slope down to the centreline by more than 5°, at least two centreline suction, i.e. one branch bilge suction and one direct suction, or
 - where the bottom of the space is horizontal or slopes down to the sides, at least two suction, i.e. one branch bilge suction and one direct suction, on each side,
 - and one emergency bilge suction.
- b) If the tank top is of a particular design or shows discontinuity, additional suction may be required.
- c) Where the propulsion machinery space is located aft, suction are normally to be provided on each side at the fore end and, except where not practicable due to the shape of the space, on each side at the aft end of the space.
- d) In electrically propelled ships, provision is to be made to prevent accumulation of water under electric generators and motors.

6.5.6 Number and distribution of suction in boiler and auxiliary machinery spaces

In boiler and auxiliary compartments, bilge suction are to include:

- bilge branch suction distributed as required in [6.4.2] to [6.4.5] for cargo holds
- one direct suction.

6.6 Draining of dry spaces other than cargo holds and machinery spaces

6.6.1 General

- a) Except where otherwise specified, bilge suction are to be branch bilge suction, i.e. suction connected to a bilge main.
- b) Draining arrangements of tanks are to comply with the provisions of [7].

6.6.2 Draining of cofferdams

- a) All cofferdams are to be provided with suction pipes led to the bilge main.
- b) Where cofferdams are divided by longitudinal watertight bulkheads or girders into two or more parts, a single suction pipe led to the aft end of each part is acceptable.

6.6.3 Draining of fore and aft peaks

- a) Where the peaks are not used as tanks and bilge suction are not fitted, drainage of both peaks may be effected by hand pump suction provided that the suction lift is well within the capacity of the pump and in no case exceeds 7,3 m.
- b) Except where permitted in [5.3.3], the collision bulkhead is not to be pierced below the freeboard deck.

6.6.4 Draining of spaces above fore and aft peaks

- a) Provision is to be made for the drainage of the chain lockers and watertight compartments above the fore peak tank by hand or power pump suction.
- b) Steering gear compartments or other small enclosed spaces situated above the aft peak tank are to be provided with suitable means of drainage, either by hand or power pump bilge suction. However, in the case of rudder stock glands located below the summer load line, the bilge suction of the steering gear compartment are to be connected to the main bilge system.
- c) If the compartments referred to in b) above are adequately isolated from the adjacent 'tweendecks, they may be drained by scuppers discharging to the tunnel (or machinery space in the case of ships with machinery aft) and fitted with self-closing cocks situated in well-lighted and visible positions.

Note 1: This arrangement is not applicable to ships required to comply with [5.5], unless they are specially approved in relation to subdivision.

6.6.5 Draining of tunnels

- a) Tunnels are to be drained by means of suction connected to the main bilge system. Such suction are generally to be located in wells at the aft end of the tunnels.
- b) Where the top of the double bottom, in the tunnel, slopes down from aft to forward, an additional suction is to be provided at the forward end of this space.

6.6.6 Draining of refrigerated spaces

Provision is to be made for the continuous drainage of condensate in refrigerated and air cooler spaces. To this end, valves capable of blanking off the water draining lines of such spaces are not to be fitted, unless they are operable from an easily accessible place located above the load waterline.

6.7 Bilge pumps

6.7.1 Number and arrangement of pumps

- a) For cargo ships, at least two power pumps connected to the main bilge system are to be provided, one of which may be driven by the propulsion machinery.
- b) Bilge pumps driven by the propulsion machinery are not allowed on ships exceeding 1000 gross tonnage.

- c) Each pump may be replaced by a group of pumps connected to the bilge main, provided their total capacity meets the requirements specified in [6.7.4].
- d) Alternative arrangements, such as the use of a hand pump in lieu of a power pump, will be given special consideration by the Society.

6.7.2 Use of ejectors

One of the pumps may be replaced by a hydraulic ejector connected to a high pressure water pump and capable of ensuring the drainage under similar conditions to those obtained with the other pump.

6.7.3 Use of bilge pumps for other duties

Bilge pumps may be used for other duties, such as fire, general service, sanitary service or ballast provided that:

- such duties are of intermittent nature
- any failure of the piping systems connected to the bilge pumps does not render the bilge system inoperable
- pumps are immediately available for bilge duty when necessary.

6.7.4 Capacity of the pumps

- a) Each power bilge pump is to be capable of pumping water through the required main bilge pipe at a speed of not less than 2 m/s.
- b) The capacity of each pump or group of pumps is not to be less than:

$$Q = 0,00565 d^2$$

where:

- Q : Minimum capacity of each pump or group of pumps, in m³/h
- d : Internal diameter, in mm, of the bilge main as defined in [6.8.1].

Note 1: For cargo ships of less than 35 m in length:

- the speed of water to be considered for calculating the capacity may be reduced to 1,22 m/s
- the capacity of each pump or group of pumps is not to be less than $Q = 0,00345 d^2$.
- c) If the capacity of one of the pumps or one of the groups of pumps is less than the Rule capacity, the deficiency may be compensated by an excess capacity of the other pump or group of pumps; as a rule, such deficiency is not permitted to exceed 30% of the Rule capacity.
- d) The capacity of hand pumps is to be based on one movement once a second.
- e) Where an ejector is used in lieu of a driven pump, its suction capacity is not to be less than the required capacity of the pump it replaces.

6.7.5 Choice of the pumps

- a) Bilge pumps are to be of the self-priming type. Centrifugal pumps are to be fitted with efficient priming means, unless an approved priming system is provided to ensure the priming of pumps under normal operating conditions.
- b) Circulating or cooling water pumps connected to an emergency bilge suction need not be of the self-priming type.

- c) Sanitary, ballast and general service pumps may be accepted as independent power bilge pumps if fitted with the necessary connections to the bilge pumping system.
- d) Hand pumps are to have a maximum suction height not exceeding 7,30 m and to be operable from a position located above the load waterline.

6.7.6 Connection of power pumps

- a) Bilge pumps and other power pumps serving essential services which have common suction or discharge are to be connected to the pipes in such a way that:
 - compartments and piping lines remain segregated in order to prevent possible intercommunication
 - the operation of any pump is not affected by the simultaneous operation of other pumps.
- b) The isolation of any bilge pump for examination, repair or maintenance is to be made possible without impeding the operation of the remaining bilge pumps.

6.7.7 Electrical supply of submersible pump motors

- a) Where submersible bilge pumps are provided, arrangements are to be made to start their motors from a convenient position above the bulkhead deck.
- b) Where an additional local-starting device is provided at the motor of a permanently installed submersible bilge pump, the circuit is to be arranged to provide for the disconnection of all control wires therefrom at a position adjacent to the starter installed on the deck.

6.8 Size of bilge pipes

6.8.1 Bilge main line

- a) The diameter of the bilge main is to be calculated according to the following formula:

$$d = 25 + 1,68 \sqrt{L(B + D)}$$

where:

- d : The internal diameter of the bilge main, in mm
- L : Length of the ship is the length measured between perpendiculars taken at the extremities of the deepest subdivision load line, in m.
- B : Breadth of the ship is the extreme width from outside of frame to outside of frame at or below the deepest subdivision load line, in m.
- D : Moulded depth of the ship to the bulkhead deck, in m, provided that, in a ship having an enclosed cargo space on the bulkhead deck which is internally drained in accordance with the requirements of [8.5.3] and which extends for the full length of the ship, D is measured to the next deck above the bulkhead deck. Where the enclosed cargo spaces cover a lesser length, D is to be taken as the moulded depth to the bulkhead deck plus lh/L where l and h are the aggregate

length and height, respectively, of the enclosed cargo spaces, in m.

Note 1: In cargo ships fitted with side ballast tanks forming a double hull on the whole length of the holds, the diameter of the bilge main may be determined by introducing the actual breadth of the holds amidships as B in the above formula. The cross-section of the bilge main is, however, not to be less than twice the cross-section of the largest branch suction to these spaces.

- b) Where the bilge pumps are designed to pump from the machinery space only, the internal diameter d , in mm, of the bilge main may be less than that required in (a) but not less than that calculated with the following formula:

$$d = 35 + 3\sqrt{L_0(B + D)}$$

where:

- L_0 : Length of the engine room, in m.
 B : Breadth of the ship, in m as defined in a).
 D : Moulded depth of the ship to the bulkhead deck, in m as defined in a).

In any case, the internal section of the bilge main is not to be less than twice that of the bilge suction pipes determined from Pt C, Ch 1, Sec 8, [6.8.3].

- c) In no case is the actual internal diameter to be:
- more than 5 mm smaller than that obtained from the formula given in a) or b), or
 - less than 60 mm.

6.8.2 Distribution box branch pipes

The cross-section of any branch pipe connecting the bilge main to a bilge distribution box is not to be less than the sum of the cross-sections required for the two largest branch suctions connected to this box. However, this cross-section need not exceed that of the bilge main.

6.8.3 Branch bilge suction pipes

- a) The internal diameter, in mm, of pipes situated between distribution boxes and suctions in holds and machinery spaces is not to be less than the diameter given by the following formula (a smaller actual diameter may be accepted, as specified in [6.8.1], b):

$$d_1 = 25 + 2,16\sqrt{L_1(B + D)}$$

where:

- B and D : as defined in [6.8.1]
 L_1 : Length of the compartment, in m.
 d_1 is not to be less than 50 mm and need not exceed 100 mm.

- b) For ships which have side ballast tanks forming a double hull, the diameter of suction pipes in holds may be determined by introducing as B the actual breadth of the holds.

6.8.4 Direct suctions other than emergency suctions

- a) Direct suctions are to be suitably arranged and those in a machinery space are to be of a diameter not less than that required for the bilge main.
- b) In cargo ships having separate machinery spaces of small dimensions, the size of the direct suctions need

not exceed that given in [6.8.3] for branch bilge suctions.

6.8.5 Emergency suctions in machinery spaces

- a) The diameter of emergency bilge suction pipes is to be:
- at least two thirds of the diameter of the pump inlet in the case of steamships
 - the same as the diameter of the pump inlet in the case of motorships.
- b) Where the emergency suction is connected to a pump other than a main circulating or cooling pump, the suction is to be the same diameter as the main inlet of the pump.

6.8.6 Bilge suctions from tunnels

Bilge suction pipes to tunnel wells are not to be less than 65 mm in diameter. In ships up to 60 metres in length, this diameter may be reduced to 50 mm.

6.8.7 Scuppers in aft spaces

Any scupper provided for draining aft spaces and discharging to the tunnel is to have an internal diameter not less than 35 mm.

6.8.8 Bilge for small ships

For cargo ships of a length L , as defined in [6.8.1], under 20 m and assigned with a restricted navigation notation, as well as for sailing ships with or without auxiliary engine, the bilge system will be specially considered by the Society in each single case.

6.8.9 Bilge main for tankers

In tankers and other ships where the bilge pumps are designed to pump from the machinery space only, the internal diameter d , in mm, of the bilge main may be less than that required by the formula in [6.8.1] above, but it is to be not less than that obtained from the formula specified in Pt E, Ch 1, Sec 4 .

6.9 Bilge accessories

6.9.1 Drain valves on watertight bulkheads

- a) The fitting of drain valves or similar devices is not allowed on the collision bulkhead.
- b) On other watertight bulkheads, the fitting of drain valves or similar devices is allowed unless practical alternative draining means exist. Such valves are to be easily accessible at all times and operable from above the freeboard deck. Means indicating whether the valves are open or closed are to be provided.

6.9.2 Screw-down non-return valves

- a) Accessories are to be provided to prevent intercommunication of compartments or lines which are to remain segregated from one another. For this purpose, non-return devices are to be fitted:
- on the pipe connections to bilge distribution boxes or to the alternative valves, if any
 - on direct and emergency suctions in machinery spaces

- on the suctions of pumps which also have connections from the sea or from compartments normally intended to contain liquid
 - on flexible bilge hose connections
 - on the suctions of water bilge ejectors
 - at the open end of bilge pipes passing through deep tanks
 - in compliance with the provisions for the prevention of progressive flooding, if applicable.
- b) Screw-down and other non-return valves are to be of a recognised type which does not offer undue obstruction to the flow of water.

6.9.3 Mud boxes

In machinery spaces and shaft tunnels, termination pipes of bilge suctions are to be straight and vertical and are to be led to mud boxes so arranged as to be easily inspected and cleaned.

The lower end of the termination pipe is not to be fitted with a strum box.

6.9.4 Strum boxes

- a) In compartments other than machinery spaces and shaft tunnels, the open ends of bilge suction pipes are to be fitted with strum boxes or strainers having holes not more than 10 mm in diameter. The total area of such holes is to be not less than twice the required cross-sectional area of the suction pipe.
- b) Strum boxes are to be so designed that they can be cleaned without having to remove any joint of the suction pipe.

6.9.5 Bilge wells

- a) The wells provided for draining the various compartments are to be made of steel plate and their capacity is not to be less than 0,15 m³. In small compartments, smaller cylindrical wells may be fitted.
- b) Bilge wells are to comply with the relevant provisions of Part B.

6.9.6 Liquid sealed traps

- a) The bilge line of refrigerated spaces is to be provided with liquid sealed traps of adequate size arranged for easy cleaning and refilling with brine. These traps are to be fitted with removable grids intended to hold back waste products when defrosting.
- b) Where drain pipes from separate refrigerated rooms join a common main, each of these pipes is to be provided with a liquid sealed trap.
- c) As a general rule, liquid sealed traps are to be fitted with non-return valves. However, for refrigerated spaces not situated in the ship bottom, non-return valves may be omitted, provided this arrangement does not impair the integrity of the watertight subdivision.

6.10 Materials

6.10.1 All bilge pipes used in or under fuel storage tanks or in boiler or machinery spaces, including spaces in which

oil-settling tanks or fuel oil pumping units are situated, shall be of steel or other suitable material non-sensitive to heat.

6.11 Bilge piping arrangement

6.11.1 Passage through double bottom compartments

Bilge pipes are not to pass through double bottom compartments. If such arrangement is unavoidable, the parts of bilge pipes passing through double bottom compartments are to comply with [5.2.3].

6.11.2 Passage through deep tanks

The parts of bilge pipes passing through deep tanks intended to contain water ballast, fresh water, liquid cargo or fuel oil are normally to be contained within pipe tunnels. Alternatively, such parts are to comply with [5.2.3]; the number of joints is to be as small as possible. These pipes are to be provided at their ends in the holds with non-return valves.

6.11.3 Provision for expansion

Where necessary, bilge pipes inside tanks are to be fitted with expansion bends. Sliding joints are not permitted for this purpose.

6.11.4 Connections

Connections used for bilge pipes passing through tanks are to be welded joints or reinforced welded flange connections.

6.11.5 Access to valves and distribution boxes

All distribution boxes and manually operated valves in connection with the bilge pumping arrangement shall be in positions which are accessible under ordinary circumstances

Hand-wheels of valves controlling emergency bilge suctions are to rise at least 0,45 m above the manoeuvring floor.

7 Ballast systems

7.1 Design of ballast systems

7.1.1 Independence of ballast lines

Ballast lines are to be entirely independent and distinct from other lines except where permitted in [5.4].

7.1.2 Prevention of undesirable communication between spaces or with the sea

Ballast systems in connection with bilge systems are to be so designed as to avoid any risk of undesirable communication between spaces or with the sea. See [6.2.3].

7.1.3 Alternative carriage of ballast water and fuel oil

- a) Oily ballast systems serving tanks intended for alternative carriage of fuel oil and water ballast are to be independent of clean ballast systems:
- serving the other ballast tanks, or
 - connected to tanks also intended to contain feed water.

- b) Where tanks are intended to alternatively contain fuel oil and ballast water, the relevant piping systems are to be arranged in accordance with [11.4.4].

7.1.4 Alternative carriage of ballast water or other liquids and dry cargo

Holds and deep tanks designed for the alternative carriage of water ballast, fuel oil or dry cargo are to have their filling and suction lines provided with blind flanges or appropriate change-over devices to prevent any mishandling.

7.1.5 Alternative carriage of ballast water and feed water

Where tanks are intended to alternatively contain ballast water and feed water, the suction line is to have removable elbows for connection to the ballast and feed water systems, so as to avoid any accidental interconnection between the two systems due to manoeuvring error.

The same arrangement is required for tanks intended for ballast and vegetable oils, or for other cargoes which may not come in contact with sea water.

7.2 Ballast pumping arrangement

7.2.1 Filling and suction pipes

- All tanks including aft and fore peak and double bottom tanks intended for ballast water are to be provided with suitable filling and suction pipes connected to special power driven pumps of adequate capacity.
- Small tanks used for the carriage of domestic fresh water may be served by hand pumps.
- Suctions are to be so positioned that the transfer of sea water can be suitably carried out in the normal operating conditions of the ship. In particular, two suction may be required in long compartments.

7.2.2 Pumps

Bilge pumps may be used for ballast water transfer provided the provisions of [6.7.3] are fulfilled.

7.2.3 Passage of ballast pipes through tanks

If not contained in pipe tunnels, the parts of ballast pipes passing through tanks intended to contain fresh water, fuel oil or liquid cargo are to comply with [5.2.3].

8 Scuppers and sanitary discharges

8.1 Application

8.1.1

- This Article applies to:
 - scuppers and sanitary discharge systems, and
 - discharges from sewage tanks.
- Discharges in connection with machinery operation are dealt with in [2.8].

Note 1: Arrangements not in compliance with the provisions of this Article may be considered for the following ships:

- ships of less than 24 m in length
- cargo ships of less than 500 tons gross tonnage
- ships to be assigned restricted navigation notations
- non-propelled units.

8.2 Principle

8.2.1

- Scuppers, sufficient in number and suitable in size, are to be provided to permit the drainage of water likely to accumulate in the spaces which are not located in the ship's bottom.
- The number of scuppers and sanitary discharge openings in the shell plating is to be reduced to a minimum either by making each discharge serve as many as possible of the sanitary and other pipes, or in any other satisfactory manner.

8.3 Drainage from spaces below the freeboard deck or within enclosed superstructures and deckhouses on the freeboard deck

8.3.1 Normal arrangement

Scuppers and sanitary discharges from spaces below the freeboard deck or from within superstructures and deckhouses on the freeboard deck fitted with doors complying with the provisions of Pt B, Ch 9, Sec 6 are to be led to:

- the bilge in the case of scuppers,
- or suitable sanitary tanks in the case of sanitary discharges.

8.3.2 Alternative arrangement

The scuppers and sanitary discharges may be led overboard provided that:

- the spaces drained are located above the load waterline formed by a 5° heel, to port or starboard, at a draft corresponding to the assigned summer freeboard,
- and the pipes are fitted with efficient means of preventing water from passing inboard in accordance with:
 - [8.7] where the spaces are located below the margin line,
 - [8.8] where the spaces are located above the margin line.

Note 1: The margin line is defined as a line drawn at least 76 mm below the upper surface of the freeboard deck at side, for cargo ships.

8.4 Drainage of superstructures or deckhouses not fitted with efficient weather-tight doors

8.4.1 Scuppers leading from superstructures or deckhouses not fitted with doors complying with the requirements of Pt B, Ch 9, Sec 6 are to be led overboard.

8.5 Drainage of enclosed cargo spaces situated on the bulkhead deck or on the freeboard deck

8.5.1 General

Means of drainage are to be provided for enclosed cargo spaces situated on the freeboard deck of a cargo ship. The Society may permit the means of drainage to be dispensed with in any particular compartment if it is satisfied that, by reason of size or internal subdivision of such space, the safety of the ship is not impaired.

8.5.2 Cases of spaces located above the waterline resulting from a 5° heel

- a) Scuppers led through the shell from enclosed superstructures used for the carriage of cargo are permitted, provided the spaces drained are located above the waterline resulting from a 5° heel to port or starboard at a draught corresponding to the assigned summer freeboard. Such scuppers are to be fitted in accordance with the requirements stated in [8.7] or [8.8].
- b) In other cases, the drainage is to be led inboard in accordance with the provisions of [8.5.3].

8.5.3 Cases where the bulkhead or freeboard deck edge is immersed when the ship heels 5° or less

Where the freeboard is such that the edge of the bulkhead deck or of the freeboard deck is immersed when the ship heels 5° or less, the drainage of the enclosed cargo spaces on the bulkhead deck or on the freeboard deck is to be led to a suitable space, or spaces, of appropriate capacity, having a high water level alarm and provided with suitable arrangements for discharge overboard. In addition, it is to be ensured that:

- the number, size and arrangement of the scuppers are such as to prevent unreasonable accumulation of free water,
- the pumping arrangements take account of the requirements for any fixed pressure water-spraying fire-extinguishing system
- water contaminated with petrol or other dangerous substances is not drained to machinery spaces or other spaces where sources of ignition may be present, and
- where the enclosed cargo space is protected by a carbon dioxide fire-extinguishing system, the deck scuppers are fitted with means to prevent the escape of the smothering gas.

8.6 Arrangement of discharges from spaces below the margin line

8.6.1 Normal arrangement

Each separate discharge led through the shell plating from spaces below the margin line is to be provided with one

automatic non-return valve fitted with positive means of closing it from above the bulkhead or freeboard deck.

8.6.2 Alternative arrangement when the inboard end of the discharge pipe is above the summer waterline by more than 0,01 L

Where the vertical distance from the summer load waterline to the inboard end of the discharge pipe exceeds 0,01 L, the discharge may have two automatic non-return valves without positive means of closing, provided that the inboard valve:

- is above the deepest subdivision load line, and
- is always accessible for examination under service conditions.

8.7 Arrangement of discharges from spaces above the margin line

8.7.1 General

- a) The provisions of this sub-article are applicable only to those discharges which remain open during the normal operation of a ship. For discharges which must necessarily be closed at sea, such as gravity drains from topside ballast tanks, a single screw-down valve operated from the deck may be accepted.
- b) The position of the inboard end of discharges is related to the timber summer load waterline when a timber freeboard is assigned.

8.7.2 Normal arrangement

Normally, each separate discharge led through the shell plating from spaces above the margin line is to be provided with:

- one automatic non-return valve fitted with positive means of closing it from a position above the bulkhead or freeboard deck, or
- one automatic non-return valve and one sluice valve controlled from above the bulkhead or freeboard deck.

8.7.3 Alternative arrangement when the inboard end of the discharge pipe is above the summer waterline by more than 0,01 L

Where the vertical distance from the summer load waterline to the inboard end of the discharge pipe exceeds 0,01 L, the discharge may have two automatic non-return valves without positive means of closing, provided that:

- the inboard valve is above the level of the tropical load waterline so as to always be accessible for examination under service conditions,
- or, where this is not practicable, a locally controlled sluice valve is interposed between the two automatic non-return valves.

8.7.4 Alternative arrangement when the inboard end of the discharge pipe is above the summer waterline by more than 0,02 L

Where the vertical distance from the summer load waterline to the inboard end of the discharge pipe exceeds 0,02 L, a single automatic non-return valve without positive means of closing may be accepted subject to the approval of the Society.

8.7.5 Arrangement of discharges through manned machinery spaces

Where sanitary discharges and scuppers lead overboard through the shell in way of manned machinery spaces, the fitting at the shell of a locally operated positive closing valve together with a non-return valve inboard may be accepted. The operating position of the valve will be given special consideration by the Society.

8.7.6 Arrangement of discharges through the shell more than 450 mm below the freeboard deck or less than 600 mm above the summer load waterline

Scupper and discharge pipes originating at any level and penetrating the shell either more than 450 millimetres below the freeboard deck or less than 600 millimetres above the summer load waterline are to be provided with a non-return valve at the shell. Unless required by [8.8.2] to [8.8.4], this valve may be omitted if the piping is of substantial thickness, as per Tab 23.

8.7.7 Arrangement of discharges through the shell less than 450 mm below the freeboard deck and more than 600 mm above the summer load waterline

Scupper and discharge pipes penetrating the shell less than 450 millimetres below the freeboard deck and more than 600 millimetres above the summer load waterline are not required to be provided with a non-return valve at the shell.

8.8 Summary table of overboard discharge arrangements

8.8.1 The various arrangements acceptable for scuppers and sanitary overboard discharges are summarised in Fig 3.

8.9 Valves and pipes

8.9.1 Materials

- All shell fittings and valves are to be of steel, bronze or other ductile material. Valves of ordinary cast iron or similar material are not acceptable. All scupper and discharge pipes are to be of steel or other ductile material. Refer to [2.1].
- Plastic is not to be used for the portion of discharge line from the shell to the first valve.

8.9.2 Thickness of pipes

- The thickness of scupper and discharge pipes led to the bilge or to draining tanks is not to be less than that required in [2.2].
- The thickness of scupper and discharge pipes led to the shell is not to be less than the minimum thickness given in Tab 22 and Tab 23.

8.9.3 Operation of the valves

- Where valves are required to have positive means of closing, such means is to be readily accessible and provided with an indicator showing whether the valve is open or closed.
- Where plastic pipes are used for sanitary discharges and scuppers, the valve at the shell is to be operated from outside the space in which the valve is located.

Where such plastic pipes are located below the summer waterline (timber summer load waterline), the valve is to be operated from a position above the freeboard deck.

Refer also to App 3.

8.10 Arrangement of scuppers and sanitary discharge piping

8.10.1 Overboard discharges and valve connections

- Overboard discharges are to have pipe spigots extending through the shell plate and welded to it, and are to be provided at the internal end with a flange for connection to the valve or pipe flange.
- Valves may also be connected to the hull plating in accordance with the provisions of [2.8.3], item c).

Figure 3 : Overboard discharge arrangement

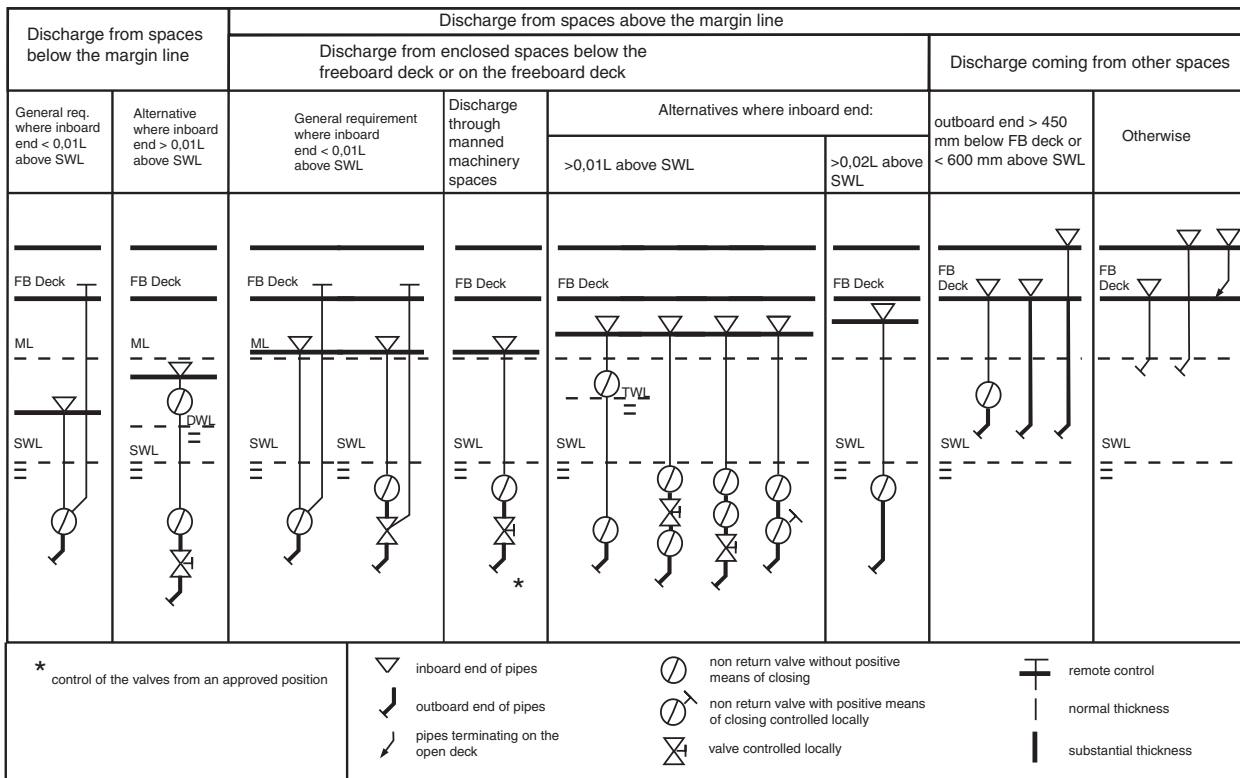

Table 22 : Thickness of scupper and discharge pipes led to the shell, according to their location

Applicable requirement →	[8.7.1]	[8.7.2]	[8.8.2]	[8.8.3]	[8.8.4]	[8.8.5]	[8.8.6] with valve	[8.8.6] without valve	[8.8.7]
Pipe location ↓									
Between the shell and the first valve	Thickness according to Tab 23, column 1, or 0,7 times that of the shell side plating, whichever is the greater (1)							NA	NA
Between the first valve and the inboard end	Thickness according to Tab 23, column 2							NA	NA
Below the freeboard deck	NA							Thickness according to Tab 23, column 1	Thickness according to Tab 23, column 2
Above the freeboard deck	NA							Thickness according to Tab 23, column 2	Thickness according to Tab 23, column 2
(1) However, this thickness is not required to exceed that of the plating.									
Note 1: NA = not applicable									

Table 23 : Minimum thickness of scupper and discharge pipes led to the shell

External diameter of the pipe d (mm)	Column 1 substantial thickness (mm)	Column 2 normal thickness (mm)
$d \leq 80,0$	7,00	4,50
155	9,25	4,50
180	10,00	5,00
220	12,50	5,80
$230 \leq d$	12,50	6,00
Note 1: Intermediate sizes may be determined by interpolation.		

8.10.2 Passage through cargo spaces

Where scupper and sanitary discharge pipes are led through cargo spaces, the pipes and the valves with their controls are to be adequately protected by strong casings or guards.

8.10.3 Passage through tanks

- As a rule, scupper and sanitary discharge pipes are not to pass through fuel oil tanks.
- Where scupper and discharge pipes pass unavoidably through fuel oil tanks and are led through the shell within the tanks, the thickness of the piping is not to be less than that given in Tab 23, column 1 (substantial thickness). It need not, however, exceed the thickness of the adjacent Rule shell plating.
- Scupper and sanitary discharge pipes are normally not to pass through fresh and drinking water tanks.
- For passage through cargo oil tanks, see Pt E, Ch 1, Sec 4.

8.10.4 Passage through watertight bulkheads or decks

- The intactness of machinery space bulkheads and of tunnel plating required to be of watertight construction is not to be impaired by the fitting of scuppers discharging to machinery spaces or tunnels from adjacent compartments which are situated below the freeboard deck.
- Such scuppers may, however, be led into a strongly constructed scupper drain tank situated in the machinery space or tunnel, but close to the above-mentioned adjacent compartments and drained by means of a suction of appropriate size led from the main bilge line through a screw-down non-return valve.

8.10.5 Discharge in refrigerated spaces

No scupper pipe from non-refrigerated spaces is to discharge in refrigerated spaces.

8.10.6 Discharge from galleys and their stores

Discharges from galleys and their stores are to be kept separate from other discharges and be drained overboard or in separate drainage tanks; alternatively, discharges are to be

provided with adequate devices against odours and overflow.

8.10.7 Discharge from aft spaces

Where spaces located aft of the aft peak bulkhead not intended to be used as tanks are drained by means of scuppers discharging to the shaft tunnel, the provisions of [6.6.4], item c) are to be complied with.

8.10.8 Scupper tank

- The scupper tank air pipe is to be led to above the freeboard deck.
- Provision is to be made to ascertain the level of water in the scupper tank.

9 Air, sounding and overflow pipes**9.1 Air pipes****9.1.1 Principle**

Air pipes are to be fitted to all tanks, double bottoms, cofferdams, tunnels and other compartments which are not fitted with alternative ventilation arrangements, in order to allow the passage of air or liquid so as to prevent excessive pressure or vacuum in the tanks or compartments, in particular in those which are fitted with piping installations. Their open ends are to be so arranged as to prevent the free entry of sea water in the compartments.

9.1.2 Number and position of air pipes

- Air pipes are to be so arranged and the upper part of compartments so designed that air or gas likely to accumulate at any point in the compartments can freely evacuate.
- Air pipes are to be fitted opposite the filling pipes and/or at the highest parts of the compartments, the ship being assumed to be on an even keel.
- In general, two air pipes are to be fitted for each compartment, except in small compartments, where only one air pipe may be accepted. When the top of the compartment is of irregular form, the position of air pipes will be given special consideration by the Society.
- Where only one air pipe is provided, it is not to be used as a filling pipe.

9.1.3 Location of open ends of air pipes

- Air pipes of double bottom compartments, tunnels, deep tanks and other compartments which can come into contact with the sea or be flooded in the event of hull damage are to be led to above the bulkhead deck or the freeboard deck.

Note 1: In ships not provided with a double bottom, air pipes of small cofferdams or tanks not containing fuel oil or lubricating oil may discharge within the space concerned.

- Air pipes of tanks intended to be pumped up are to be led to the open above the bulkhead deck or the freeboard deck.

- c) Air pipes other than those of fuel oil tanks may be led to enclosed cargo spaces situated above the freeboard deck, provided that such spaces are fitted with scuppers discharging overboard, which are capable of draining all the water which may enter through the air pipes without giving rise to any water accumulation.
- d) Air pipes of tanks other than oil tanks may discharge through the side of the superstructure.
- e) The air pipe of the scupper tank is to be led to above freeboard deck.
- f) The location of air pipes for flammable oil tanks is also to comply with [9.1.7].

9.1.4 Height of air pipes

- a) The height of air pipes extending above the freeboard deck or superstructure deck from the deck to the point where water may have access below is to be at least:
 - 760 mm on the freeboard deck, and
 - 450 mm on the superstructure deck.This height is to be measured from the upper face of the deck, including sheathing or any other covering, up to the point where water may penetrate inboard.
- b) Where these heights may interfere with the working of the ship, a lower height may be approved, provided the Society is satisfied that this is justified by the closing arrangements and other circumstances. Satisfactory means which are permanently attached are to be provided for closing the openings of the air pipes.
- c) The height of air pipes may be required to be increased on ships for the purpose of compliance with buoyancy calculations.
- d) The height of air pipes discharging through the side of the superstructure is to be at least 2,3 m above the summer load waterline.

Note 1: For ships to be assigned a restricted service notation, the height of air pipes may be reduced to:

- 450 mm on the freeboard deck,
- 300 mm on the superstructure deck.

9.1.5 Fitting of closing appliances

- a) Satisfactory appliances which are permanently attached are to be provided for closing the openings of air pipes in order to prevent the free entry of water into the spaces concerned.
- b) Closing appliances are to be of automatic type in the following cases:
 - when fitted on exposed parts of freeboard deck and first superstructure deck,
 - where, with the ship at its summer load waterline, the openings are immersed at an angle of heel of 40° or, at the angle of down-flooding if the latter is less than 40°,
 - where, as per [9.1.3], item c), air pipes terminate in enclosed spaces,
 - where, as per [9.1.4], item b), air pipes have a height lower than that required in [9.1.4], item a),

- and for ships assigned timber freeboard.

See also Pt B, Ch 3, Sec 2, [2.1.2] and Pt F, Ch 10, Sec 9, [2.1.4].

- c) Automatic closing appliances are to be of a type approved by the Society. Requirements for type tests are given in [20.2.2].
- d) For ships subject to specific buoyancy or stability requirements, or for ships not subject to the 1966 International Convention on Load Lines in force, the fitting of closing appliances to air pipes will be given special consideration.
- e) Pressure/vacuum valves installed on cargo tanks, as per Part E, Chapter 1, can be accepted as closing appliances.

9.1.6 Design of closing appliances

- a) When closing appliances are requested to be of an automatic type, they are to comply with the following:
 - They are to be so designed that they withstand both ambient and working conditions up to an inclination of -40° to +40° without failure or damage.
 - They are to be so designed as to allow inspection of the closure and the inside of the casing as well as changing of the seals.
 - Where they are of the float type, suitable guides are to be provided to ensure unobstructed operation under all working conditions of heel and trim.
 - Efficient ball or float seating arrangements are to be provided for the closures. Bars, a cage or other devices are to be provided to prevent the ball or float from contacting the inner chamber in its normal state and made in such a way that the ball or float is not damaged when subjected to water impact due to a tank being overfilled.
 - They are to be self-draining.
 - The clear area through an air pipe closing appliance is to be at least equal to the area of the inlet.
 - The maximum allowable tolerances for wall thickness of floats is not to exceed ±10% of the nominal thickness.
 - Their casings are to be of approved metallic materials adequately protected against corrosion.
 - Closures and seats made of non-metallic materials are to be compatible with the media to be carried in the tank and with sea water at ambient temperatures between -35°C and 85°C.
 - The inner and outer chambers of an automatic air pipe head are to be of a minimum thickness of 6 mm.
 - For galvanised steel air pipe heads, the zinc coating is to be applied by the hot method and the thickness is to be 70 to 100 microns.
 - For areas of the head susceptible to erosion (e.g. those parts directly subjected to ballast water impact when the tank is being pressed up, for example the inner chamber area above the air pipe, plus an overlap of 10° or more either side), an additional harder coating is to be applied. This is to be an aluminium

bearing epoxy, or other equivalent, coating, applied over the zinc.

- b) Where closing appliances are not of an automatic type, provision is to be made for relieving vacuum when the tanks are being pumped out. For this purpose, a hole of approximately 10 mm in diameter may be provided in the bend of the air pipe or at any other suitable position in the closing appliance.
- c) Wooden plugs and trailing canvas are not permitted in position 1 or position 2, as defined in Pt B, Ch 1, Sec 2.

9.1.7 Special arrangements for air pipes of flammable oil tanks

- a) Air and overflow pipes and relief valves of fuel oil and thermal oil systems are to discharge to a position on the open deck where there is no risk of fire or explosion from the emergence of oils and vapour.

The open ends are to be fitted with flame screens made of corrosion resistant material and readily removable for cleaning and replacement. The clear area of such screens is not to be less than the cross-sectional area of the pipe.

- b) Air pipes of lubricating or hydraulic oil storage tanks not subject to flooding in the event of hull damage may be led to machinery spaces, provided that in the case of overflowing the oil cannot come into contact with electrical equipment, hot surfaces or other sources of ignition.
- c) The location and arrangement of vent pipes for fuel oil service, settling and lubrication oil tanks are to be such that in the event of a broken vent pipe there is no risk of ingress of seawater or rainwater.
- d) Air pipes of fuel oil service, settling and lubrication oil tanks likely to be damaged by impact forces are to be adequately reinforced.
- e) Where seawater or rainwater may enter fuel oil service, settling and lubrication oil tanks through broken air pipes, arrangements such as water traps with:
 - automatic draining, or
 - alarm for water accumulation
 are to be provided.

9.1.8 Construction of air pipes

- a) Where air pipes to ballast and other tanks extend above the freeboard deck or superstructure deck, the exposed parts of the pipes are to be of substantial construction, with a minimum wall thickness of at least:
 - 6,0 mm for pipes of 80 mm or smaller external diameter
 - 8,5 mm for pipes of 165 mm or greater external diameter,
 Intermediate minimum thicknesses may be determined by linear interpolation.
- b) Air pipes with height exceeding 900 mm are to be additionally supported.
- c) In each compartment likely to be pumped up, and where no overflow pipe is provided, the total cross-sectional area of air pipes is not to be less than 1,25 times

the cross-sectional area of the corresponding filling pipes.

- d) The internal diameter of air pipes is not to be less than 50 mm, except for tanks of less than 2 m³.

9.1.9 Green sea loads

The requirements in [9.1.9] and in [9.1.10] apply to strength checks of air pipes and their closing devices located within the forward quarter length of the ship, for ships of length L 80 m or greater, where the height of the exposed deck in way of the item is less than 0,1L or 22 m above the summer load waterline, whichever is the lesser. However, these requirements do not apply to the pipes of cargo tank venting systems and inert gas systems in ships with one of the service notations **oil tanker ESP, FLS tanker and tanker**.

The pressures p , in kN/m² acting on air pipes and their closing devices may be calculated from:

$$p = 0,5 \rho V^2 C_d C_s C_p$$

where:

- L : ship length as defined in Pt B, Ch 1, Sec 2, [3.1]
- ρ : density of sea water (1,025 t/m³)
- V : velocity of water over the fore deck (13,5 m/s)
- C_d : shape coefficient
= 0,5 for pipes, 1,3 for air pipes in general, 0,8 for an air pipe of cylindrical form with its axis in the vertical direction.
- C_s : slamming coefficient (3,2)
- C_p : protection coefficient:
 - (0,7) for pipes located immediately behind a breakwater or forecastle,
 - (1,0) elsewhere and immediately behind a bulwark.

Forces acting in the horizontal direction on the pipe and its closing device may be calculated from the pressure specified in this requirement using the largest projected area of each component.

9.1.10 Strength Requirements

These requirements are additional to those specified in [9.1.6] a), in [20.2.2] and in [9.1.8] a).

- a) Bending moments and stresses in air pipes are to be calculated at critical positions: at penetration pieces, at weld or flange connections, at toes of supporting brackets. Bending stresses in the net section are not to exceed 0,8 σ_y , where σ_y is the specified minimum yield stress, or 0,2% proof stress of the steel at room temperature. Irrespective of corrosion protection, a corrosion addition of 2,0 mm is then to be applied to the net section.
- b) For standard air pipes of 760 mm height closed by heads of not more than the tabulated projected area, pipe thicknesses and bracket heights are specified in Tab 24.

Where brackets are required, three or more radial brackets are to be fitted. Brackets are to be of at least 8 mm gross thickness, minimum 100 mm in length and height according to Tab 24, but need not extend over the joint flange for the head. Bracket toes at the deck are to be suitably supported.

- c) For other configurations, loads according to [9.1.9] are to be applied, and means of support determined in order to comply with the requirements specified in a). Where fitted, brackets are to be of suitable thickness and length according to their height. Pipe thickness is not to be taken less than as indicated in [9.1.8] a).
- d) All component parts and connections of the air pipe are to be capable of withstanding the loads defined in [9.1.9].

9.2 Sounding pipes

9.2.1 Principle

- a) Sounding devices are to be fitted to tanks intended to contain liquids as well as to all compartments which are not readily accessible at all times.
- b) For compartments normally intended to contain liquids, the following systems may be accepted in lieu of sounding pipes:
 - a level gauge of an approved type efficiently protected against shocks, or
 - a remote level gauging system of an approved type, provided an emergency means of sounding is available in the event of failure affecting such system.

Table 24 : 760 mm Air Pipe Thickness and Bracket Standards

Nominal pipe diameter (mm)	Minimum fitted gross thickness (mm)	Maximum projected area of head (cm ²)	Height (1) of brackets (mm)
65	6,0	-	480
80	6,3	-	460
100	7,0	-	380
125	7,8	-	300
150	8,5	-	300
175	8,5	-	300
200	8,5 (2)	1900	300 (2)
250	8,5 (2)	2500	300 (2)
300	8,5 (2)	3200	300 (2)
350	8,5 (2)	3800	300 (2)
400	8,5 (2)	4500	300 (2)

(1) Brackets (see [9.1.10]) need not extend over the joint flange for the head.
 (2) Brackets are required where the as fitted (gross) thickness is less than 10,5 mm, or where the tabulated projected head area is exceeded.
Note 1: For other air pipe heights, the relevant requirements in [9.1.10] are to be applied.

9.2.2 Position of sounding pipes

Sounding pipes are to be located as close as possible to suction pipes.

9.2.3 Termination of sounding pipes

- a) As a general rule, sounding pipes are to end above the bulkhead deck or the freeboard deck in easily accessible places and are to be fitted with efficient, permanently attached, metallic closing appliances.
- b) In machinery spaces and tunnels, where the provisions of a) cannot be satisfied, short sounding pipes led to readily accessible positions above the floor and fitted with efficient closing appliances may be accepted.

In ships required to be fitted with a double bottom, such closing appliances are to be of the self-closing type.

9.2.4 Special arrangements for sounding pipes of flammable oil tanks

- a) Where sounding pipes are used in flammable (except lubricating) oil systems, they are to terminate in the open air, where no risk of ignition of spillage from the sounding pipe might arise. In particular, they are not to terminate in passenger or crew spaces. As a general rule, they are not to terminate in machinery spaces. However, where the Society considers that this requirement is impracticable, it may permit termination in machinery spaces on condition that the following provisions are satisfied:

- 1) in addition, an oil-level gauge is provided meeting the provisions of [2.9.2]
- 2) the sounding pipes terminate in locations remote from ignition hazards unless precautions are taken, such as the fitting of effective screens, to prevent the fuel oil in the case of spillage through the terminations of the sounding pipes from coming into contact with a source of ignition
- 3) the terminations of sounding pipes are fitted with self-closing blanking devices and with a small diameter self-closing control cock located below the blanking device for the purpose of ascertaining before the blanking device is opened that fuel oil is not present. Provision is to be made so as to ensure that any spillage of fuel oil through the control cock involves no ignition hazard.

- b) For lubricating oil and fuel oil leakage tanks less than 2 m³, the oil-level gauge mentioned in a).1 and the control cock mentioned in a).3 need not be provided on condition that the sounding pipes are fitted with appropriate means of closure.

- c) Short sounding pipes may be used for tanks other than double bottom tanks without the additional closed level gauge provided an overflow system is fitted.

9.2.5 Closing appliances

- a) Self-closing appliances are to be fitted with cylindrical plugs having counterweights such as to ensure automatic closing.
- b) Closing appliances not required to be of the self-closing type may consist of a metallic screw cap secured to the pipe by means of a chain or a shut-off valve.

9.2.6 Construction of sounding pipes

- a) Sounding pipes are normally to be straight. If it is necessary to provide bends in such pipes, the curvature is to be as small as possible to permit the ready passage of the sounding apparatus.
- b) In cargo ships, the sounding arrangement of compartments by means of bent pipes passing through other compartments will be given special consideration by the Society. Such an arrangement is normally accepted only if the compartments passed through are cofferdams or are intended to contain the same liquid as the compartments served by the sounding pipes.
- c) Bent portions of sounding pipes are to have reinforced thickness and be suitably supported.
- d) The internal diameter of sounding pipes is not to be less than 32 mm. Where sounding pipes pass through refrigerated spaces, or through the insulation of refrigerated spaces in which the temperature may be below 0°C, their internal diameter is to be at least 60 mm.
- e) Doubling plates are to be placed under the lower ends of sounding pipes in order to prevent damage to the hull. When sounding pipes with closed lower ends are used, the closing plate is to have reinforced scantlings.

9.3 Overflow pipes

9.3.1 Principle

Overflow pipes are to be fitted to tanks:

- which can be filled by pumping and are designed for a hydrostatic pressure lower than that corresponding to the height of the air pipe, or
- where the cross-sectional area of air pipes is less than that prescribed in [9.1.8], item c).

9.3.2 Design of overflow systems

- a) Overflow pipes are to be led:
 - either outside,
 - or, in the case of fuel oil or lubricating oil, to an overflow tank of adequate capacity or to a storage tank having a space reserved for overflow purposes.
- b) Where tanks containing the same or different liquids are connected to a common overflow system, the arrangement is to be such as to prevent any risk of:
 - intercommunication between the various tanks due to movements of liquid when emptying or filling, or due to the inclination of the ship
 - overflowing of any tank from another assumed flooded due to hull damage.

For this purpose, overflow pipes are to be led to a high enough point above the deepest load waterline or, alternatively, non-return valves are to fitted where necessary.

- c) Arrangements are to be made so that a compartment cannot be flooded from the sea through the overflow in the event of another compartment connected to the same overflow main being bilged. To this end, the openings of overflow pipes discharging overboard are as a rule to be placed above the deepest load waterline and are to be fitted where necessary with non-return valves on the plating, or, alternatively, overflow pipes from

tanks are to be led to a point above the deepest load waterline.

- d) Where deep tanks which can be used to contain liquid or dry cargo or fuel oil are connected to a common overflow system, arrangements are to be made so that liquid or vapours from other compartments cannot enter such tanks when carrying dry cargo.
- e) Where tanks alternately containing fuel oil and ballast water are connected to a common overflow system, arrangements are to be made to prevent the ballast water overflowing into the tanks containing fuel oil and vice-versa.
- f) Additional requirements for ships subject to damage stability checks are given in [5.5.3].

9.3.3 Overflow tanks

- a) Overflow tanks are to have a capacity sufficient to receive the delivery of the pumps for at least 10 minutes.
- b) Overflow tanks are to be fitted with an air pipe complying with [9.1] which may serve as an overflow pipe for the same tank. When the vent pipe reaches a height exceeding the design head of the overflow tank, suitable means are to be provided to limit the actual hydrostatic head on the tank.

Such means are to discharge to a position which is safe in the opinion of the Society.

- c) An alarm device is to be provided to give warning when the oil reaches a predetermined level in the tank, or alternatively, a sight-flow glass is to be provided in the overflow pipe to indicate when any tank is overflowing. Such sight-flow glasses are only to be placed on vertical pipes and in readily visible positions.

9.3.4 Specific requirements for construction of overflow pipes

- a) The internal diameter of overflow pipes is not to be less than 50 mm.
- b) In each compartment which can be pumped up, the total cross-sectional area of overflow pipes is not to be less than 1,25 times the cross-sectional area of the corresponding filling pipes.
- c) The cross-sectional area of the overflow main is not to be less than the aggregate cross-sectional area of the two largest pipes discharging into the main.

9.4 Constructional requirements applying to sounding, air and overflow pipes

9.4.1 Materials

- a) Sounding, air and overflow pipes are to be made of steel or any other material approved for the application considered.
- b) Exposed parts of sounding, air and overflow pipes are to be made of approved metallic materials.

9.4.2 Minimum thickness of steel pipes

The minimum thickness of sounding, air and overflow steel pipes is given in Tab 25.

Table 25 : Minimum wall thickness of sounding, air and overflow pipes

External diameter (mm)	Minimum wall thickness (mm) (1)
up to 168,3	4,5
177,8	5,0
193,7	5,4
219,1	5,9
above 244,5	6,3
(1) Applies only to structural tanks. For independent tanks, refer to Tab 5.	

9.4.3 Passage of pipes through certain spaces

- a) Air pipes and sounding pipes led through refrigerated cargo holds or spaces are to be suitably insulated.
- b) When sounding, air and overflow pipes made of steel are permitted to pass through ballast tanks or fuel oil tanks, they are to comply with [5.2.3].
- c) Sounding, air and overflow pipes passing through cargo holds are to be adequately protected.

9.4.4 Self-draining of pipes

Air pipes and overflow pipes are to be so arranged as to be self-draining when the ship is on an even keel.

9.4.5 Name plates

Nameplates are to be fixed at the upper part of air pipes and sounding pipes.

10 Cooling systems**10.1 Application**

10.1.1 This article applies to all cooling systems using the following cooling media:

- sea water
- fresh water
- lubricating oil.

Air cooling systems will be given special consideration.

10.2 Principle**10.2.1 General**

Sea water and fresh water cooling systems are to be so arranged as to maintain the temperature of the cooled media (lubricating oil, hydraulic oil, charge air, etc.) for propulsion machinery and essential equipment within the manufacturers' recommended limits during all operations, including starting and manoeuvring, under the inclination angles and the ambient conditions specified in Sec 1.

10.2.2 Availability of the cooling system

The cooling system is to be so designed that, in the event of one essential component being inoperative, the cooling of propulsion machinery is maintained. Partial reduction of the propulsion capability may be accepted, however, when it is demonstrated that the safe operation of the ship is not impaired.

10.3 Design of sea water cooling systems**10.3.1 General**

- a) Sea water cooling of the propulsion engines, auxiliary engines and other essential equipment is to be capable of being supplied by two different means.
- b) Where required, standby pumps are not to be connected to the sea inlet serving the other sea water pumps, unless permitted under [10.7.1], item b).

10.3.2 Centralised cooling systems

- a) In the case of centralised cooling systems, i.e. systems serving a group of propulsion engines and/or auxiliary engines, reduction gears, compressors and other essential equipment, the following sea water pumps are to be arranged:
 - one main cooling water pump, which may be driven by the engines, of a capacity sufficient to provide cooling water to all the equipment served
 - one independently driven standby pump of at least the same capacity
- b) Where the cooling system is served by a group of identical pumps, the capacity of the standby pump needs only to be equivalent to that of each of these pumps.
- c) Ballast pumps or other suitable sea water pumps of appropriate capacity may be used as standby pumps, provided arrangements are made against overpressure in the cooling system.
- d) In ships having one or more propulsion engines, each with an output not exceeding 375 kW, the independent standby pump may be replaced by a complete spare pump of appropriate capacity ready to be connected to the cooling circuit.
- e) In cases of centralised cooling systems serving only a group of auxiliary engines, the second means of cooling may consist of a connection to a cooling water pump serving the propulsion plant, provided such pump is of sufficient capacity to provide cooling water to both propulsion plant and auxiliary engines.

10.3.3 Individual cooling of propulsion engines

- a) Individual cooling systems of propulsion engines are to include at least:
 - one main cooling water pump, which can be driven by the engine
 - one independently driven standby pump
 Where the output of the engine does not exceed 375 kW, the following arrangements may be accepted:
 - one main cooling water pump, which can be driven by the engine
 - one spare pump of appropriate capacity ready to be connected to the cooling circuit
- b) Where, in ships having more than one engine per propeller or having several propellers, each engine is served by its own cooling circuit, the second means requested in [10.3.1] is to be provided, consisting of:
 - a connection to an independently driven pump, such as a ballast pump or any other suitable sea water pump of sufficient capacity provided arrange-

ments against overpressure in the cooling system are made. (See [10.7.4], b)),

- or a complete spare pump identical to those serving the engines and ready to be connected to the cooling circuit.

This second means may be omitted, however, when safety justifications are provided as regards the propulsion and manoeuvring capabilities of the ship with one cooling circuit disabled.

10.3.4 Individual cooling of auxiliary engines

Where each auxiliary engine is served by its own cooling circuit, no second means of cooling is required.

10.3.5 Cooling of steam plants

a) Steam plants are to be fitted with:

- a main circulating pump
- a standby pump capable of ensuring the circulation in the main condenser in the event of failure of the main circulating pump.

b) Where the installation includes more than one propulsive unit, the standby pump is not required, provided a branch pipe is fitted between the discharges of the circulating pumps of each unit.

c) In lieu of the main circulating pump, a sea inlet scoop system may be accepted, provided that an additional means is fitted to ensure the circulation of sea water to the condenser when the ship is manoeuvring. Such means may be:

- an additional independent pump,
- or a connection to an available pump of sufficient capacity.

10.3.6 Cooling of other essential equipment

a) The second means of cooling required in [10.3.1] for essential equipment may consist of a connection to a ballast pump or other suitable sea water pump of sufficient capacity, provided arrangements are made against overpressure in the cooling system. (See [10.7.4], item b)).

b) However, where such essential equipment is duplicate, this second means may be omitted when safety justifications are provided as regards the propulsion and manoeuvring capabilities of the ship with the cooling circuit of one set of equipment disabled.

10.4 Design of fresh water cooling systems

10.4.1 General

Fresh water cooling systems are to be designed according to the applicable requirements of [10.3].

10.4.2 Cooling systems

a) Fresh water cooling systems of essential equipment are to include at least:

- one main cooling water pump, which can be driven by the equipment
- one independently driven standby pump.

b) The standby pump may be omitted provided an emergency connection to a suitable sea water system is fitted

and arranged with a suitable change-over device. Provisions against overpressure in the cooling system are to be made in accordance with [10.7.4], item b).

c) The standby pump may also be omitted in the case of redundancy of the cooled equipment.

10.4.3 Expansion tanks

Fresh water expansion tanks are to be provided with at least:

- a de-aerating device
- a water level indicator
- a filling connection
- a drain.

10.4.4 Detection of fuel oil or lubricating oil

A device is to be fitted in fresh water cooling systems comprising fuel oil or lubricating oil heat exchangers in order to detect any contamination of the water by fuel oil or lubricating oil.

10.5 Design of oil cooling systems

10.5.1 General

Oil cooling systems are to be designed according to the applicable requirements of [10.3].

10.5.2 Second means of cooling

The second means of cooling requested in [10.3.1] may consist of a satisfactory connection to a lubricating oil pump of sufficient capacity. Arrangements are to be made against overpressure in the cooling system.

10.6 Control and monitoring

10.6.1 General

In addition to those of this item [10.6], the general requirements given in Chapter 3 apply.

In the case of ships with automation notations, the requirements in Part F, Chapter 2 also apply.

10.6.2 Alarms are to be provided for water cooling systems in accordance with Tab 26, in addition to the requirements stated for diesel engines in Sec 2 and for steam plants in Sec 4.

Note 1: Some departures from Tab 26 may be accepted by the Society in the case of ships with a restricted navigation notation.

10.7 Arrangement of cooling systems

10.7.1 Sea inlets

a) At least two sea inlets complying with [2.8] are to be provided for the cooling system, one for each means of cooling required in [10.3.1].

b) The two sea inlets may be connected by a cross-over supplying both main cooling pump and standby cooling pump.

c) When the second means of cooling is a spare pump, the two sea inlets are to be provided in any event, both serving the main cooling pump.

d) The sea inlets are to be low inlets, so designed as to remain submerged under all normal navigating conditions.

In general, one sea inlet is to be arranged on each side of the ship.

e) One of the sea inlets may be that of the ballast pump or of the general service pump.

10.7.2 Coolers

a) Coolers are to be fitted with isolating valves at the inlets and outlets.

b) Coolers external to the hull (chest coolers and keel coolers) are to be fitted with isolating valves at the shell.

10.7.3 Filters

a) Where propulsion engines and auxiliary engines for essential services are directly cooled by sea water, both in normal service and in emergency operating conditions, filters are to be fitted on the suction of cooling pumps.

b) These filters are to be so arranged that they can be cleaned without interrupting the cooling water supply.

10.7.4 Pumps

a) Cooling pumps for which the discharge pressure may exceed the design pressure of the piping system are to be fitted with relief valves in accordance with [2.5].

b) Where general service pumps, ballast pumps or other pumps may be connected to a cooling system, arrangements are to be made, in accordance with [2.5], to avoid overpressure in any part of the cooling system.

10.7.5 Air venting

Cocks are to be installed at the highest points of the pipes conveying cooling water to the water jackets for venting air or gases likely to accumulate therein. In the case of closed

fresh water cooling systems, the cock is to be connected to the expansion tank.

11 Fuel oil systems

11.1 Application

11.1.1 Scope

This Article applies to all fuel oil systems supplying any kind of installation.

11.1.2 Requirements applying to fuel oil systems and not contained in this Section

Additional requirements are given:

- for independent fuel oil tanks, in App 4
- for fuel oil supply equipment forming part of engines, boilers, thermal heaters and incinerators, in the corresponding sections
- for the location and scantling of tanks forming part of the ship's structure, in Part B, Chapter 2.

11.2 Principle

11.2.1 General

a) Fuel oil systems are to be so designed as to ensure the proper characteristics (purity, viscosity, pressure) of the fuel oil supply to engines and boilers.

- b) Fuel oil systems are to be so designed as to prevent:
- overflow or spillage of fuel oil from tanks, pipes, fittings, etc.
 - fuel oil from coming into contact with sources of ignition
 - overheating and seizure of fuel oil.

c) Fuel oils used for engines and boilers are to have a flashpoint complying with the provisions of Sec 1.

Table 26 : Cooling systems

Symbol convention H = High, HH = High high, G = group alarm L = Low, LL = Low low, I = individual alarm X = function is required, R = remote	Monitoring		Automatic control				
			System			Auxiliary	
Identification of system parameter	Alarm	Indication	Slow-down	Shut-down	Control	Stand by Start	Stop
Sea water pump pressure or flow	L	local					
Fresh water pump pressure or flow	L	local					
Level in cooling water expansion tank	L	local					

11.2.2 Availability of fuel systems

- a) Fuel oil systems are to be so designed that, in the event that any one essential auxiliary of such systems becomes inoperative, the fuel oil supply to boilers and engines can be maintained (see also [11.2.1] a)). Partial reduction of the propulsion capability may be accepted, however, when it is demonstrated that the safe operation of the ship is not impaired.
- b) Fuel oil tanks are to be so arranged that, in the event of damage to any one tank, complete loss of the fuel supply to essential services does not occur.
- c) Where engines and boilers are operated with heavy fuel oils, provisions are to be made to supply them with fuel oils which do not need to be heated.

11.2.3 Drains on fuel oil piping

11.3 General

11.3.1 Arrangement of fuel oil systems

- a) In a ship in which fuel oil is used, the arrangements for the storage, distribution and utilisation of the fuel oil are to be such as to ensure the safety of the ship and persons on board.
- b) The provisions of [5.10] are to be complied with.

11.3.2 Provision to prevent overpressure

Provisions are to be made to prevent overpressure in any oil tank or in any part of the fuel oil system. Any relief valve is to discharge to a safe position.

11.3.3 Ventilation

The ventilation of machinery spaces is to be sufficient under all normal conditions to prevent accumulation of oil vapour.

11.3.4 Access

Spaces where fuel oil is stored or handled are to be readily accessible.

11.4 Design of fuel oil filling and transfer systems

11.4.1 General

- a) A system of pumps and piping for filling and transferring fuel oil is to be provided.
- b) Provisions are to be made to allow the transfer of fuel oil from any storage, settling or service tank to another tank.

11.4.2 Filling systems

- a) Filling pipes of fuel oil tanks are to terminate on open deck or in filling stations isolated from other spaces and efficiently ventilated. Suitable coamings and drains are to be provided to collect any leakage resulting from filling operations.
- b) Arrangements are to be made to avoid overpressure in the filling lines which are served by pumps on board. Where safety valves are provided for this purpose, they

are to discharge to the overflow tank referred to in [9.3.3] or to other safe positions deemed satisfactory.

11.4.3 Independence of fuel oil transfer lines

Except where permitted in [11.4.5], the fuel oil transfer piping system is to be completely separate from the other piping systems of the ship.

11.4.4 Simultaneous transfer of fuel oil and ballast water

Where, under the provisions of [7.1.3], tanks are intended to alternately contain fuel oil and ballast water, the piping arrangement is to be such that fuel may be transferred by means of fuel pumps to or from any tank while ballast pumps are simultaneously being used.

11.4.5 Alternative carriage of fuel oil, ballast water or other liquid and dry cargo

Where certain compartments are likely to contain alternatively fuel oil, ballast water and other liquid or dry cargo, the transfer pipes supplying these compartments are to be fitted with blind flanges or other appropriate change-over devices.

11.4.6 Transfer pumps

- a) At least two means of transfer are to be provided. One of these means is to be a power pump. The other may consist of:
 - a standby pump,
 - or, alternatively, an emergency connection to another suitable power pump.

Note 1: Where provided, purifiers may be accepted as means of transfer.

- b) Where necessary, transfer pumps are to be fitted on their discharge side with a relief valve leading back to the suction of the pump or to any other place deemed satisfactory.

11.5 Arrangement of fuel oil tanks and bunkers

11.5.1 Location of fuel oil tanks

- a) No fuel oil tank is to be situated where spillage or leakage therefrom can constitute a hazard by falling on heated surfaces.
- b) Fuel oil tanks and bunkers are not to be situated immediately above boilers or in locations where they could be subjected to high temperatures, unless specially agreed by the Society. In general, the distance between fuel oil tanks and boilers is not to be less than 450 mm. Where boilers are situated above double bottom fuel oil tanks, the distance between the double bottom tank top and the lower metallic part of the boilers is not to be less than:
 - 750 mm for water tube boilers,
 - 600 mm for cylindrical boilers.
- c) As far as practicable, fuel oil tanks are to be part of the ship's structure and are to be located outside machinery spaces of category A. Where fuel oil tanks, other than double bottom tanks, are necessarily located adjacent to or within machinery spaces of category A, at least one

of their vertical sides is to be contiguous to the machinery space boundaries, and is preferably to have a common boundary with the double bottom tanks, and the area of the tank boundary common with the machinery spaces is to be kept to a minimum. Where such tanks are situated within the boundaries of machinery spaces of category A, they are not to contain fuel oil having a flashpoint of less than 60 °C.

Note 1: Machinery spaces of category A are defined in Ch 4, Sec 1.

- d) The location of fuel oil tanks is to be in compliance with the requirements of Part B, Chapter 2, particularly as regards the installation of cofferdams, the separation between fuel oil tanks or bunkers and the other spaces of the ship, and the protection of these tanks and bunkers against any abnormal rise in temperature.
- e) Attention is drawn to the requirements of Pt E, Ch 1, Sec 4 regarding the segregation of fuel bunkers from the cargo area.

11.5.2 Use of free-standing fuel oil tanks

- a) In general the use of free-standing fuel oil tanks is to be avoided except on cargo ships, where their use is permitted in category A machinery spaces.
- b) For the design and the installation of independent tanks, refer to App 4.

11.6 Design of fuel oil tanks and bunkers

11.6.1 General

Tanks such as collector tanks, de-aerator tanks etc. are to be considered as fuel oil tanks for the purpose of application of this sub-article, and in particular regarding the valve requirements.

Tanks with a volume lower than 500 l will be given special consideration by the Society.

11.6.2 Scantlings

- a) The scantlings of fuel oil tanks and bunkers forming part of the ship's structure are to comply with the requirements stated in Part B.
- b) Scantlings of fuel oil tanks and bunkers which are not part of the ship's structure are to comply with App 4. For cases which are not contained in the Tables of that appendix, scantlings will be given special consideration by the Society.

11.6.3 Filling and suction pipes

- a) All suction pipes from fuel oil tanks and bunkers, including those in the double bottom, are to be provided with valves.
- b) For storage tanks, filling pipes may also be used for suction purposes.
- c) Where the filling pipes to fuel oil bunkers and tanks are not led to the upper part of the such bunkers and tanks, they are to be provided with non-return valves at their ends, unless they are fitted with valves arranged in accordance with the requirements stated in [11.6.4].

11.6.4 Remote control of valves

- a) Every fuel oil pipe which, if damaged, would allow oil to escape from a storage, settling or daily service tank having a capacity of 500 l and above situated above the double bottom, is to be fitted with a cock or valve directly on the tank capable of being closed from a safe position outside the space in which such tanks are situated in the event of a fire occurring in such space.

Note 1: For the location of the remote controls, refer to [11.10.4], item c).

- b) Such valves and cocks are also to include local control and on the remote and local controls it is to be possible to verify whether they are open or shut. (See [2.7.3].)
- c) In the special case of deep tanks situated in any shaft or pipe tunnel or similar space, valves are to be fitted on the tank but control in the event of fire may be effected by means of an additional valve on the pipe or pipes outside the tunnel or similar space. If such additional valve is fitted in the machinery space it is to be operated from a position outside this space.

11.6.5 Drain pipes

Where fitted, drain pipes are to be provided with self-closing valves or cocks.

11.6.6 Air and overflow pipes

Air and overflow pipes are to comply with [9.1] and [9.3].

11.6.7 Sounding pipes and level gauges

- a) Safe and efficient means of ascertaining the amount of fuel oil contained in any fuel oil tank are to be provided.
- b) Sounding pipes of fuel oil tanks are to comply with the provisions of [9.2].
- c) Oil-level gauges complying with [2.9.2] may be used in place of sounding pipes.
- d) Gauge cocks for ascertaining the level in the tanks are not to be used.

11.7 Design of fuel oil heating systems

11.7.1 General

- a) Where heavy fuel oil is used, a suitable heating system is to be provided for storage tanks, settling tanks and service tanks in order to ensure that the fuel oil has the correct fluidity and the fuel pumps operate efficiently.
- b) Where necessary for pumping purposes, storage tanks containing heavy fuel oil are to be provided with heating systems.
- c) Where necessary, pumps, filters, pipes and fittings are to be provided with heat tracing systems.
- d) Where main or auxiliary engines are supplied with fuel oil which needs to be heated, arrangements are to be made so that the engines can still operate if one oil heating system or the heating power source is out of action. Such arrangements may consist of an alternative supply of the engines in accordance with [11.9.2].

11.7.2 Tank heating systems

- a) Fuel oil in storage tanks is not to be heated to temperatures within 10°C below the flashpoint of the fuel oil. Fuel oil in service tanks, settling tanks and any other tanks in the supply system may be heated above this limit, provided:
 - the length of the vent pipes from such tanks and/or a cooling device is sufficient for cooling the vapours to at least 10°C below the flashpoint of the fuel oil and a temperature sensor is fitted in the vent pipe and adjusted to give an alarm if the temperature should exceeds a limit set at 10°C below the flashpoint of the fuel, or the outlet of the vent pipes is located 3 m away from a source of ignition
 - the vent pipes are fitted with suitable flame screens
 - there are no openings from the vapour space of the fuel tanks into machinery spaces (bolted manholes are acceptable)
 - enclosed spaces are not located directly over such fuel tanks, except for well ventilated cofferdams
 - electrical equipment is not fitted in the vapour space of the tanks, unless it is certified to be intrinsically safe.
- b) The temperature of the heating medium is not to exceed 220°C.
- c) Automatic control sensors are to be provided for each heated tank to maintain the temperature of the fuel oil below the limits prescribed in a) above.
- d) Heated tanks are to be provided with temperature measuring systems.

11.7.3 Fuel oil heaters

- a) Where steam heaters or heaters using other heating media are provided in fuel oil systems, they are to be fitted with at least a high temperature alarm or a low flow alarm in addition to a temperature control, except where temperatures dangerous for the ignition of the fuel oil cannot be reached.
- b) Electric heating of fuel oil is to be avoided as far as practicable.
- c) However, when electric heaters are fitted, means are to be provided to ensure that heating elements are permanently submerged during operation. In all cases a safety temperature switch is to be fitted in order to avoid a surface temperature of 220°C and above. It is to be:
 - independent from the automatic control sensor
 - designed to cut off the electrical power supply in the event of excessive temperature
 - provided with manual reset.
- d) Fuel oil heaters are to be fitted with relief valves leading back to the pump suction concerned or to any other place deemed satisfactory.

11.8 Design of fuel oil treatment systems

11.8.1 General

- a) Heavy fuel oils used in diesel engines are to be purified and filtered according to the engine manufacturer's requirements.
- b) Provisions are to be made to avoid inadvertent entry of non-purified heavy fuel into the daily service tanks, in particular through the overflow system.

11.8.2 Drains

- a) Settling tanks or, where settling tanks are not provided, daily service tanks, are to be provided with drains permitting the evacuation of water and impurities likely to accumulate in the lower part of such tanks.
- b) Efficient means are to be provided for draining oily water escaping from the drains.

11.8.3 Purifiers

- a) Where fuel oil needs to be purified, at least two purifiers are to be installed on board, each capable of efficiently purifying the amount of fuel oil necessary for the normal operation of the engines.

Note 1: On ships with a restricted navigation notation where fuel oil needs to be purified, one purifier only may be accepted.

- b) Subject to special consideration by the Society, the capacity of the standby purifier may be less than that required in a), depending on the arrangements made for the fuel oil service tanks to satisfy the requirement in [11.9.2].
- c) The standby purifier may also be used for other services.
- d) Each purifier is to be provided with an alarm in case of failures likely to affect the quality of the purified fuel oil.

11.9 Design of fuel supply systems

11.9.1 General

- a) In ships where heavy fuel oil and marine diesel oil are used, a change-over system from one fuel to the other is to be provided. This system is to be so designed as to avoid:
 - overheating of marine diesel oil
 - inadvertent ingress of heavy fuel oil into marine diesel oil tanks.
- b) When necessary, arrangements are to be made for cooling the marine diesel oil from engine return lines.

11.9.2 Fuel oil service tanks

- a) Two fuel oil service tanks for each type of fuel used on board necessary for propulsion and vital systems, or equivalent arrangements, are to be provided on each new ship, with a capacity of at least 8 h at maximum continuous rating of the propulsion plant and normal operating load at sea of the generator plant.
- b) Where main engines, auxiliary engines and boilers are operated with heavy fuel oil, the following equivalent arrangements may be accepted for fuel oil service tanks:
 - one heavy fuel oil service tank with a capacity of at least 8 h at maximum continuous rating of the pro-

pulsion plant and normal operating load at sea of the generator plant and of the auxiliary boiler

- one marine diesel oil service tank with a capacity of at least 8 h at maximum continuous rating of the propulsion plant and normal operating load at sea of the generator plant and of the auxiliary boiler.
- c) Where main engine and auxiliary boilers are operated with heavy fuel oil and auxiliary engines are operated with marine diesel oil, the following equivalent arrangements may be accepted for fuel oil service tanks:
- one heavy fuel oil service tank with a capacity of at least 8 h at maximum continuous rating of the propulsion plant and normal operating load at sea of the auxiliary boiler
 - two marine diesel oil service tanks, each with a capacity of at least the higher of:
 - 8 h at normal operating load at sea of the auxiliary engines
 - 4 h at maximum continuous rating of the propulsion plant and normal operating load at sea of the generator plant and of the auxiliary boiler.

Note 1: The requirement in [11.9.2] need not be applied to cargo ships of less than 500 tons gross tonnage:

- intended for restricted service or
- having engines declared suitable for prolonged operation on untreated fuel oil.

11.9.3 Fuel oil supply to boilers

- a) In ships where boilers burning oil under pressure are installed to supply steam for propulsion purposes and essential services (such as propulsion machinery, machinery serving essential services or systems essential for propulsion and other essential services, e.g. heavy fuel oil heating system), the fuel oil supply system is to include at least two units, each one comprising:
- a suction filter
 - an independent pump
 - a heater in the case of heavy fuel oil
 - a discharge filter.
- b) Alternative arrangements using double filters are acceptable provided the element of one such filter can be cleaned while the other operates.
- c) The fuel oil supply system is to be capable of supplying the fuel oil necessary to generate enough steam for propulsion purposes and essential services with one unit out of action.
- d) A quick-closing valve is to be provided on the fuel supply to the burners of each boiler, arranged to be easily operated in case of emergency, either directly or by remote control.
- e) The fuel supply to the burners is to be capable of being automatically cut off when required under Sec 3, [5.1.8].
- f) Burners are to comply with Section Sec 3, [2.2.5].
- g) Where burners are provided with fuel oil flow-back to the pump suction or other parts under pressure, non-

return devices are to be provided to prevent fuel oil from flowing back to the burners when the oil supply is cut off.

- h) For the starting-up of boilers, an auxiliary fuel oil unit not requiring power from shore is to be provided.
- i) Where fuel oil is supplied to the burners by gravity, a double filter satisfying the provisions of a) is to be provided in the supply line.
- j) Fuel oil supply systems are to be entirely separate from feed, bilge, ballast and other piping systems.

11.9.4 Fuel oil supply to internal combustion engines

- a) The suction of engine fuel pumps are to be so arranged as to prevent the pumping of water and sludge likely to accumulate after decanting at the lower part of service tanks.
- b) Suitable filters are to be provided on the fuel oil line to the injection pumps.

Internal combustion engines intended for main propulsion are to be fitted with at least two filters, or similar devices, so arranged that one of the filters can be overhauled while the other is in use.

Note 1: Where the propulsion plant consists of:

- two or more engines, each one with its own filter, or
- one engine with an output not exceeding 375 kW,

the second filter may be replaced by a readily accessible and easily replaceable spare filter.

- c) Oil filters fitted in parallel are to be so arranged as to minimise the possibility of a filter under pressure being opened by mistake.

Filter chambers are to be provided with suitable means for:

- ventilating when put into operation
- de-pressurising before being opened.

Valves or cocks used for this purpose are to be fitted with drain pipes led to a safe location.

- d) Oil filters are to be so located that in the event of a leakage the fuel oil cannot be pulverised onto the exhaust manifold.

- e) When an fuel oil booster pump is fitted which is essential to the operation of the main engine, a standby pump, connected ready for immediate use, is to be provided.

The standby pump may be replaced by a complete spare pump of appropriate capacity ready to be connected, in the following cases:

- where two or more main engines are fitted, each with its own booster pump
- in ships having main engines each with an output not exceeding 375 kW.

- f) Where fuel oils require pre-heating in order to have the appropriate viscosity when being injected in the engine, the following equipment is to be provided in the fuel oil line:
- one viscosity control and monitoring system
 - two pre-heaters, one serving as a standby for the other.
- g) Excess fuel oil from pumps or injectors is to be led back to the service or settling tanks, or to other tanks intended for this purpose.
- h) De-aeration tanks fitted in pressurised fuel oil return lines are to be equipped with at least:
- an automatic venting valve or equivalent device discharging to the daily service tank
 - a non-return valve in the return line from the engines.
- i) Components of a diesel engine fuel system are to be designed considering the maximum peak pressure which will be experienced in service, including any high pressure pulses which are generated and transmitted back into the fuel supply and spill lines by the action of fuel injection pumps.
- j) Connections within the fuel supply and spill lines are to be constructed having regard to their ability to prevent pressurised fuel oil leaks while in service and after maintenance.
- k) In multi-engine installations which are supplied from the same fuel source, means of isolating the fuel supply and spill piping to individual engines, are to be provided. The means of isolation are not to affect the operation of the other engines and are to be operable from a position not rendered inaccessible by a fire on any of the engines.
- l) For high pressure fuel oil pipes, refer to Sec 2.

11.10 Control and monitoring

11.10.1 General

In addition to those of this item [11.10], the general requirements given in Chapter 3 apply.

In the case of ships with automation notations, the requirements in Part F, Chapter 2 also apply.

11.10.2 Monitoring

Alarms and safeguards are to be provided for fuel oil systems in accordance with Tab 27.

Note 1: Some departures from Tab 27 may be accepted by the Society in the case of ships with a restricted navigation notation.

11.10.3 Automatic controls

Automatic temperature control is to be provided for:

- steam heaters or heaters using other media
- electric heaters.

11.10.4 Remote controls

- a) The remote control arrangement of valves fitted on fuel oil tanks is to comply with [11.6.4].

- b) The power supply to:
- fuel oil burning pumps,
 - transfer pumps and other pumps of the fuel oil system,
 - and fuel oil purifiers,
- is to be capable of being stopped from a position within the space containing the pumps and from another position located outside such space and always accessible in the event of fire within the space.
- c) Remote control of the valve fitted to the emergency generator fuel tank is to be in a separate location from that of other valves fitted to tanks in the engine room.
- d) The positions of the remote controls are also to comply with Chapter 3.

11.11 Construction of fuel oil piping systems

11.11.1 Materials

- a) Fuel oil pipes and their valves are to be of steel or other approved material, except that the use of flexible pipes may be accepted provided they comply with [2.6.2].
- b) Where the Society may permit the conveying of oil and combustible liquids through accommodation and service spaces, the pipes conveying oil or combustible liquids are to be of a material approved by the Society having regard to the fire risk.
- c) For valves fitted to fuel oil tanks and which are under a static pressure head, steel or nodular cast iron may be accepted. However, ordinary cast iron valves may be used in fuel piping systems where the design pressure is lower than 0,7 MPa and the design temperature is below 60°C.
- d) Internal galvanisation of fuel oil pipes and tank or bunker walls is to be avoided.

11.11.2 Pipe thickness

The thickness of pipes containing fuel oil is to be calculated for a design pressure according to Tab 28.

11.11.3 Pipe connections

- a) Connections and fittings of pipes containing fuel oil are to be suitable for a design pressure according to Tab 28.
- b) Connections of pipes conveying heated fuel oil are to be made by means of close-fitting flanges, with joints made of a material impervious to oil heated to 160°C and as thin as possible.

11.12 Arrangement of fuel oil piping systems

11.12.1 Passage of fuel oil pipes through tanks

- a) Fuel pipes are not to pass through tanks containing boiler feed water, fresh water, other flammable oil or liquid cargo, unless they are contained within tunnels.
- b) Transfer pipes passing through ballast tanks are to comply with [5.2.3].

11.12.2 Passage of pipes through fuel oil tanks

Boiler feed water, fresh water or liquid cargo pipes are not to pass through fuel oil tanks, unless such pipes are contained within tunnels.

11.12.3 Drains on fuel oil piping

Where fitted, drain pipes on fuel oil piping are to be provided with self-closing valves or cocks.

12 Lubricating oil systems**12.1 Application****12.1.1**

This Article applies to lubricating oil systems serving diesel engines, reverse and reduction gears, for lubrication or control purposes.

It also applies to separate oil systems intended for the cooling of engine pistons.

Table 27 : Fuel oil systems

Symbol convention H = High, HH = High high, G = group alarm L = Low, LL = Low low, I = individual alarm X = function is required, R = remote	Monitoring		Automatic control				
			System			Auxiliary	
Identification of system parameter	Alarm	Indication	Slow-down	Shut-down	Control	Stand by Start	Stop
Fuel oil overflow tank level	H (1)						
Air pipe water trap level on fuel oil tanks	H (2)						
Fuel oil temperature after heaters	H (4)	local		X (5)			
Sludge tank level		local					
Fuel oil settling tank and service tank temperature	H (3)	local					
Fuel oil level in daily service tank	L+H (1)	local					
Fuel oil daily service tank temperature	H (3)	local					
(1) Or sightglasses on the overflow pipe (2) Or alternative arrangement as per [9.1.7] item c) (3) Applicable where heating arrangements are provided (4) Or low flow alarm in addition to temperature control when heated by steam or other media (5) Cut off of electrical power supply when electrically heated							

Table 28 : Definition of the design pressure for fuel oil systems

Working temperature → Working pressure ↓	T ≤ 60°C	T > 60°C
P ≤ 0,7 MPa	0,3 MPa or maximum working pressure, whichever is the greater	0,3 MPa or maximum working pressure, whichever is the greater
P > 0,7 MPa	maximum working pressure	1,4 MPa or maximum working pressure, whichever is the greater

12.2 Principle

12.2.1 General

- a) Lubricating oil systems are to be so designed as to ensure reliable lubrication of the engines and other equipment, including electric motors, intended for propulsion:
 - over the whole speed range, including starting, stopping and, where applicable, manoeuvring
 - for all the inclinations angles stated in Sec 1
- b) Lubricating oil systems are to be so designed as to ensure sufficient heat transfer and appropriate filtration of the oil.
- c) Lubricating oil systems are to be so designed as to prevent oil from entering into contact with sources of ignition.

12.2.2 Availability

- a) Lubricating oil systems are to be so designed that, in the event that any one pump is inoperative, the lubrication of the engines and other equipment is maintained. Partial reduction of the propulsion capability may be accepted, however, when it is demonstrated that the safe operation of the ship is not impaired.
- b) An emergency lubricating system, such as a gravity system, is to be provided to ensure sufficient lubrication of equipment which may be damaged due to a failure of the pump supply.

12.3 General

12.3.1 Arrangement of lubricating oil systems

- a) The arrangements for the storage, distribution and utilisation of oil used in pressure lubrication systems are to be such as to ensure the safety of the ship and persons on board.
- b) The provisions of [5.10] are to be complied with, where applicable.

12.3.2 Filtration

- a) In forced lubrication systems, a device is to be fitted which efficiently filters the lubricating oil in the circuit.
- b) The filters provided for this purpose for main machinery and machinery driving electric propulsion generators are to be so arranged that they can be easily cleaned without stopping the lubrication of the machines.
- c) The fineness of the filter mesh is to comply with the requirements of the engine manufacturers.
- d) Where filters are fitted on the discharge side of lubricating oil pumps, a relief valve leading back to the suction or to any other convenient place is to be provided on the discharge of the pumps.

12.3.3 Purification

Where provided, lubricating oil purifiers are to comply with [11.8.3].

12.3.4 Heaters

Lubricating oil heaters are to comply with [11.7.3].

12.4 Design of engine lubricating oil systems

12.4.1 Lubrication of propulsion engines

- a) Main engines are to be provided with at least two power lubricating pumps, of such a capacity as to maintain normal lubrication with any one pump out of action.
- b) In the case of propulsion plants comprising:
 - more than one engine, each with its own lubricating pump, one of the pumps mentioned in a) may be a spare pump, provided the arrangements are such as to enable the ship to proceed at a full load speed of not less than 7 knots when one of the engines is out of service, or
 - one engine with an output not exceeding 375 kW, one of the pumps mentioned in a) may be a spare pump ready to be connected to the lubricating oil system, provided disassembling and reassembling operations can be carried out on board in a short time.

12.4.2 Lubrication of auxiliary engines

- a) For auxiliary engines with their own lubricating pump, no additional pump is required.
- b) For auxiliary engines with a common lubricating system, at least two pumps are to be provided. However, when such engines are intended for non-essential services, no additional pump is required.

12.5 Design of lubricating oil tanks

12.5.1 Remote control of valves

Lubricating oil tanks with a capacity of 500 litres and above are to be fitted with remote controlled valves in accordance with the provisions of [11.6.4]. Where it is determined that the unintended operation of a quick closing valve on the oil lubricating tank would endanger the safe operation of the main propulsion and essential auxiliary machinery remote controlled valves need not be installed.

Suction valves from storage tanks need not be arranged with remote controls provided they are kept closed except during transfer operations.

12.5.2 Filling and suction pipes

Filling and suction pipes are to comply with the provisions of [11.6.3].

12.5.3 Air and overflow pipes

Air and overflow pipes are to comply with the provisions of [9.1] and [9.3].

12.5.4 Sounding pipes and level gauges

- a) Safe and efficient means of ascertaining the amount of lubricating oil contained in the tanks are to be provided.
- b) Sounding pipes are to comply with the provisions of [9.2].
- c) Oil-level gauges complying with [2.9.2] may be used in place of sounding pipes.
- d) Gauge cocks for ascertaining the level in the tanks are not to be used.

12.5.5 Oil collecting tanks for engines

- a) In ships required to be fitted with a double bottom, wells for lubricating oil under main engines may be permitted by the Society provided it is satisfied that the arrangements give protection equivalent to that afforded by a double bottom complying with Pt B, Ch 4, Sec 4.
- b) Where, in ships required to be fitted with a double bottom, oil collecting tanks extend to the outer bottom, a valve is to be fitted on the oil drain pipe, located between the engine sump and the oil drain tank. This valve is to be capable of being closed from a readily accessible position located above the working platform. Alternative arrangements will be given special consideration.
- c) Oil collecting pipes from the engine sump to the oil collecting tank are to be submerged at their outlet ends.

12.6 Control and monitoring

12.6.1 General

In addition to those of this item [12.7], the general requirements given in Chapter 3 apply.

In the case of ships with automation notations, the requirements in Part F, Chapter 2 also apply.

12.6.2 Monitoring

In addition to the requirements in Sec 2 for diesel engines and in Sec 6 for gears, alarms are to be provided for lubricating oil systems in accordance with Tab 29.

Note 1: Some departures from Tab 29 may be accepted by the Society in the case of ships with a restricted navigation notation.

12.7 Construction of lubricating oil piping systems

12.7.1 Materials

Materials used for oil piping system in machinery spaces are to comply with the provisions of [11.11.1].

12.7.2 Sight-flow glasses

The use of sight-flow glasses in lubricating systems is permitted, provided that they are shown by testing to have a suitable degree of fire resistance.

13 Thermal oil systems

13.1 Application

13.1.1 This Article applies to all thermal oil systems involving organic liquids heated below their initial boiling temperature at atmospheric pressure by means of:

- oil fired heaters,
- exhaust gas heaters,
- or electric heaters.

13.2 Principle

13.2.1 General

Thermal oil systems are to be so designed as to:

- avoid overheating of the thermal oil and contact with air
- take into account the compatibility of the thermal oil with the heated products in case of contact due to leakage of coils or heater tubes
- prevent oil from coming into contact with sources of ignition.

13.2.2 Availability

Thermal oil systems are to be so designed that, in the event that any one essential auxiliary is inoperative, the thermal oil supply to essential services can be maintained. Partial reduction of the propulsion capability may be accepted, however, when it is demonstrated that the safe operation of the ship is not impaired.

Table 29 : Lubricating oil systems

Symbol convention H = High, HH = High high, G = group alarm L = Low, LL = Low low, I = individual alarm X = function is required, R = remote	Monitoring		Automatic control				
			System			Auxiliary	
Identification of system parameter	Alarm	Indication	Slow-down	Shut-down	Control	Stand by Start	Stop
Air pipe water trap level of lubricating oil tank (1)	H						
Sludge tank level		local					
(1) See [9.1.7]							

13.3 General

13.3.1 Limitations on use of thermal oil

- a) The oil is to be used in the temperature ranges specified by the producer. The delivery temperature is, however, to be kept 50°C below the oil distillation point.
- b) Thermal oil is not to be used for the direct heating of:
 - accommodation,
 - fresh drinking water
 - liquid cargoes with flashpoints below 60°C, except where permitted in Part F, Chapter 2.

13.3.2 Location of thermal oil system components

Thermal oil heaters are normally to be located in spaces separated from main and auxiliary machinery spaces.

However, thermal oil heaters located in machinery spaces and protected by adequate screening may be accepted, subject to special consideration by the Society.

Note 1: For the purpose of application of Chapter 4, spaces where thermal oil heaters are located are to be considered as machinery spaces of category A.

13.3.3 Provision for quick drainage and alternative arrangements

- a) Inlet and outlet valves of oil fired and exhaust fired heaters are to be arranged for remote closing from outside the compartment where they are situated.

As an alternative, thermal oil systems are to be arranged for quick gravity drainage of the thermal oil contained in the system into a draining tank.

- b) The expansion tank is to be arranged for quick gravity drainage into a draining tank.

However, where the expansion tank is located in a low fire risk space, the quick drainage system may be replaced by a remote controlled closing device for isolating the expansion tank.

The quick drainage system and the alternative closing device are to be capable of being controlled from inside and outside the space containing the expansion tank.

13.3.4 Ventilation

- a) Spaces containing thermal oil heaters are to be suitably mechanically ventilated.
- b) Ventilation is to be capable of being stopped from outside these spaces.

13.4 Design of thermal oil heaters and heat exchangers

13.4.1 Thermal oil heaters

Oil fired and exhaust-fired thermal oil heaters are to be designed, equipped and controlled in accordance with the requirements specified in Sec 3.

13.4.2 Heat exchangers

Heat exchangers are to be designed and equipped in accordance with the requirements specified in Sec 3.

13.5 Design of storage, expansion and draining tanks

13.5.1 Storage and draining tanks

- a) The capacity of the storage tank is to be sufficient to compensate the losses expected in service.
- b) The capacity of the draining tank is to be sufficient to collect the quantity of thermal oil contained in the system, including the expansion tank.
- c) Storage and draining tanks may be combined.

13.5.2 Expansion tanks

- a) The capacity of the expansion tank is to be sufficient to allow volume variations, due to temperature changes, of all the circulating oil.
- b) The expansion tank is to be so designed, installed and connected to the circuit as to ensure that the temperature inside the tank remains below 50°C.

13.5.3 Drain pipes

Where provided, drain pipes of thermal oil tanks are to be fitted with self-closing valves or cocks.

13.5.4 Air pipes

- a) Air pipes fitted to the expansion and drainage tanks are to be suitably sized to allow the quick gravity drainage referred to in [13.3.3].
- b) The applicable requirements of [9.1] are to be complied with.

13.5.5 Overflow pipes

- a) The expansion tank is to be fitted with an overflow pipe led to the drainage tank. This overflow pipe may be combined with the quick draining line provided for in [13.3.3], item b).
- b) The applicable requirements of [9.3] are to be complied with.

13.5.6 Sounding pipes and level gauges

- a) Sounding pipes are to comply with the provisions of [9.2].
- b) Level gauges are to comply with the provisions of [2.9.2].

13.6 Design of circulation and heat exchange systems

13.6.1 Circulating pumps

At least two circulating pumps are to be provided, of such a capacity as to maintain a sufficient flow in the heaters with any one pump out of action.

However, for circulating systems supplying non-essential services, one circulating pump only may be accepted.

13.6.2 Filters

A device which efficiently filters the thermal oil is to be provided in the circuit.

In the case of essential services, the filters provided for this purpose are to be so arranged that they can be easily cleaned without stopping the thermal oil supply.

The fineness of the filter mesh is to comply with the requirements of the thermal oil heating installation manufacturer.

13.7 Control and monitoring

13.7.1 General

In addition to those of this item [13.7], the general requirements given in Chapter 3 apply.

In the case of ships with automation notations, the requirements in Part F, Chapter 2 also apply.

13.7.2 Monitoring

In addition to the requirements specified in Sec 3, [2.5.2] for thermal heaters and heat exchangers, alarms and safeguards for thermal oil systems are to be provided in accordance with Sec 3, Tab 20.

Note 1: Some departures from Sec 3, Tab 20 may be accepted by the Society in the case of ships with a restricted navigation notation.

13.7.3 Remote control

- a) Remote control is to be arranged for:
- shut-off of circulating pumps
 - inlet and outlet valves of heaters (see item a) of [13.3.3])
 - quick drainage of expansion tank, or shut-off of the alternative devices (see item b) of [13.3.3])
 - shut-off of the fuel supply to the oil fired heaters or of the exhaust gas supply to the exhaust gas heaters (see Sec 3, [5.3]).
- b) Such control is to be possible from the space containing the thermal oil heaters and from another position located outside such space.

13.8 Construction of thermal oil piping systems

13.8.1 Materials

- a) Materials are to comply with the provisions of [11.11.1].
- b) Casings of pumps, valves and fittings are to be made of steel or other ductile material.

13.8.2 Pipe connections

- a) Pipe connections are to comply with Article [2.4] and to be suitable for the design temperature of the thermal oil system.
- b) Screw couplings of a type approved by the Society may be accepted for pipes of an outside diameter not exceeding 15 mm provided they are fitted with cutting rings or equivalent arrangements.
- c) The materials of the joints are to be impervious to thermal oil.

13.9 Thermal oil piping arrangements

13.9.1 Passage of thermal oil pipes through certain spaces

- a) Thermal oil pipes are not to pass through accommodation or public spaces or control stations.
- b) Thermal oil pipes passing through main and auxiliary machinery spaces are to be restricted as far as possible.

13.9.2 Discharge of relief valves

Relief valves are to discharge to the drain tank.

13.9.3 Provision for de-aerating

Provisions are to be made for automatic evacuation of air, steam and gases from the thermal oil system to a safe location.

14 Hydraulic systems

14.1 Application

14.1.1 Hydraulic installations intended for essential services

Unless otherwise specified, this Article applies to all hydraulic power installations intended for essential services, including:

- actuating systems of thrusters
- actuating systems of steering gear
- actuating systems of lifting appliances
- manoeuvring systems of hatch covers
- manoeuvring systems of stern, bow and side doors and bow visors
- manoeuvring systems of mobile ramps, movable platforms, elevators and telescopic wheelhouses
- starting systems of diesel engines
- remote control of valves.

14.1.2 Hydraulic installations located in spaces containing sources of ignition

Hydraulic power installations not serving essential services but located in spaces where sources of ignition are present are to comply with the provisions of [14.3.2], [14.3.3], [14.4.3] and [14.4.4].

14.1.3 Low pressure or low power hydraulic installations

Hydraulic power installations with a design pressure of less than 2,5 MPa and hydraulic power packs of less than 5 kW will be given special consideration by the Society.

14.1.4 Very high pressure hydraulic installations

Hydraulic power installations with a design pressure exceeding 35 MPa will be given special consideration by the Society.

14.2 Principle

14.2.1 General

Hydraulic systems are to be so designed as to:

- avoid any overload of the system
- maintain the actuated equipment in the requested position (or the driven equipment at the requested speed)
- avoid overheating of the hydraulic oil
- prevent hydraulic oil from coming into contact with sources of ignition.

14.2.2 Availability

- a) Hydraulic systems are to be so designed that, in the event that any one essential component becomes inoperative, the hydraulic power supply to essential services can be maintained. Partial reduction of the propulsion capability may be accepted, however, when it is demonstrated that the safe operation of the ship is not impaired. Such reduction of capability is not acceptable for steering gear.
- b) When a hydraulic power system is simultaneously serving one essential system and other systems, it is to be ensured that:
 - any operation of such other systems, or
 - any failure in the whole installation external to the essential system
 does not affect the operation of the essential system.
- c) Provision b) applies in particular to steering gear.
- d) Hydraulic systems serving lifting or hoisting appliances, including platforms, ramps, hatch covers, lifts, etc., are to be so designed that a single failure of any component of the system may not result in a sudden undue displacement of the load or in any other situation detrimental to the safety of the ship and persons on board.

14.3 General

14.3.1 Definitions

- a) A power unit is the assembly formed by the hydraulic pump and its driving motor.
- b) An actuator is a component which directly converts hydraulic pressure into mechanical action.

14.3.2 Limitations of use of hydraulic oils

- a) Oils used for hydraulic power installations are to have a flashpoint not lower than 150°C and be suitable for the entire service temperature range.
- b) The hydraulic oil is to be replaced in accordance with the specification of the installation manufacturer.

14.3.3 Location of hydraulic power units

- a) Whenever practicable, hydraulic power units are to be located outside main engine or boiler rooms.
- b) Where this requirement is not complied with, shields or similar devices are to be provided around the units in order to avoid an accidental oil spray or mist on heated surfaces which may ignite oil.

14.4 Design of hydraulic systems

14.4.1 Power units

- a) Hydraulic power installations are to include at least two power units so designed that the services supplied by the hydraulic power installation can operate simultaneously with one power unit out of service. A reduction of the performance not affecting the safety of the ship may be accepted, except for steering gear.
- b) Low power hydraulic installations not supplying essential services may be fitted with a single power unit, provided that alternative means, such as a hand pump, are available on board.

14.4.2 Filtering equipment

- a) A device is to be fitted which efficiently filters the hydraulic oil in the circuit.
- b) Where filters are fitted on the discharge side of hydraulic pumps, a relief valve leading back to the suction or to any other convenient place is to be provided on the discharge of the pumps.

14.4.3 Provision for cooling

Where necessary, appropriate cooling devices are to be provided.

14.4.4 Provision against overpressure

- a) Safety valves of sufficient capacity are to be provided at the high pressure side of the installation.
- b) Safety valves are to discharge to the low pressure side of the installation or to the service tank.

14.4.5 Provision for venting

Cocks are to be provided in suitable positions to vent the air from the circuit.

14.5 Design of hydraulic tanks and other components

14.5.1 Hydraulic oil service tanks

- a) Service tanks intended for hydraulic power installations supplying essential services are to be provided with at least:
 - a level gauge complying with [2.9.2]
 - a temperature indicator
 - a level switch complying with [14.6.3]. The level switch may be omitted in the case of hydraulic systems capable of being operated only in local position.
- b) The free volume in the service tank is to be at least 10% of the tank capacity.

14.5.2 Hydraulic oil storage tanks

- a) Hydraulic power installations supplying essential services are to include a storage tank of sufficient capacity to refill the whole installation should the need arise case of necessity.
- b) For hydraulic power installations of less than 5 kW, the storage means may consist of sealed drums or tins stored in satisfactory conditions.

14.5.3 Hydraulic accumulators

The hydraulic side of the accumulators which can be isolated is to be provided with a relief valve or another device offering equivalent protection in case of overpressure.

14.6 Control and monitoring

14.6.1 General

In addition to those of this item [14.6], the general requirements given in Chapter 3 apply.

In the case of ships with automation notations, the requirements in Part F, Chapter 2 also apply.

14.6.2 Indicators

Arrangements are to be made for connecting a pressure gauge where necessary in the piping system.

14.6.3 Monitoring

Alarms and safeguards for hydraulic power installations intended for essential services, except steering gear, for which the provisions of Sec 11 apply, are to be provided in accordance with Tab 30 .

Note 1: Some departures from Tab 30 may be accepted by the Society in the case of ships with a restricted navigation notation.

Note 2: Tab 30 does not apply to steering gear.

14.7 Construction of hydraulic oil piping systems

14.7.1 Materials

- a) Pipes are to be made of seamless steel. The use of welded steel pipes will be given special consideration by the Society.
- b) Casings of pumps, valves and fittings are to be made of steel or other ductile material.

15 Steam systems

15.1 Application

15.1.1 Scope

This Article applies to all steam systems intended for essential and non-essential services.

Steam systems with a design pressure of 10 MPa or more will be given special consideration.

15.2 Principle

15.2.1 General

Steam systems are to be so designed as to:

- avoid overpressure in any part of the steam piping system
- ensure the draining of condensate from the steam line.

15.2.2 Availability

- a) Where a single boiler is installed, the steam system may supply only non-essential services.
- b) Where more than one boiler is installed, the steam piping system is to be so designed that, in the event that any one boiler is out of action, the steam supply to essential services can be maintained.

15.3 Design of steam lines

15.3.1 General

- a) Every steam pipe and every connected fitting through which steam may pass is to be designed, constructed and installed such as to withstand the maximum working stresses to which it may be subjected.
- b) When the design temperature of the steam piping system exceeds 400°C, calculations of thermal stresses are to be submitted to the Society as specified in [2.3].
- c) Steam connections on boilers and safety valves are to comply with the applicable requirements of Sec 3.

15.3.2 Provision against overpressure

- a) If a steam pipe or fitting may receive steam from any source at a higher pressure than that for which it is designed, a suitable reducing valve, relief valve and pressure gauge are to be fitted.
- b) When, for auxiliary turbines, the inlet steam pressure exceeds the pressure for which the exhaust casing and associated piping up to the exhaust valves are designed, means to relieve the excess pressure are to be provided.

15.3.3 Provision for dumping

In order to avoid overpressure in steam lines due to excessive steam production, in particular in systems where the steam production cannot be adjusted, provisions are to be made to allow the excess steam to be discharged to the condenser by means of an appropriate dump valve.

15.3.4 Provision for draining

Means are to be provided for draining every steam pipe in which dangerous water hammer action might otherwise occur.

Table 30 : Hydraulic oil systems

Symbol convention H = High, HH = High high, G = group alarm L = Low, LL = Low low, I = individual alarm X = function is required, R = remote	Monitoring		Automatic control				
			System			Auxiliary	
Identification of system parameter	Alarm	Indica- tion	Slow- down	Shut- down	Control	Stand by Start	Stop
Pump pressure	L						
Service tank level	L (1)						
(1) The low level alarm is to be activated before the quantity of lost oil reaches 100 litres or 50 % of the circuit volume , whichever is the less.							

15.3.5 Steam heating pipes

- When heating coils are fitted in compartments likely to contain either fuel oil or liquid or dry cargoes, arrangements such as blind flanges are to be provided in order to disconnect such coils in the event of carriage of dry or liquid cargoes which are not to be heated.
- The number of joints on heating coils is to be reduced to the minimum consistent with dismantling requirements.

15.3.6 Steam lines in cargo holds

- Live and exhaust steam pipes are generally not to pass through cargo holds, unless special provisions are made with the Society's agreement.
- Where steam pipes pass through cargo holds in pipe tunnels, provision is to be made to ensure the suitable thermal insulation of such tunnels.
- When a steam smothering system is provided for cargo holds, provision is to be made to prevent any damage of the cargo by steam or condensate leakage.

15.3.7 Steam lines in accommodation spaces

Steam lines are not to pass through accommodation spaces, unless they are intended for heating purposes.

15.3.8 Turbine connections

- A sentinel valve or equivalent is to be provided at the exhaust end of all turbines. The valve discharge outlets are to be visible and suitably guarded if necessary.
- Bled steam connections are to be fitted with non-return valves or other approved means to prevent steam and water returning to the turbines.

15.3.9 Strainers

- Efficient steam strainers are to be provided close to the inlets to ahead and astern high pressure turbines or, alternatively, at the inlets to manoeuvring valves.
- Where required by the manufacturer of the auxiliaries, steam strainers are also to be fitted in the steam lines supplying these auxiliaries.

16 Boiler feed water and condensate systems

16.1 Application

16.1.1 This Article applies to:

- feed water systems of oil fired and exhaust gas boilers
- steam drain and condensate systems.

16.2 Principle

16.2.1 General

Boiler feed water and condensate systems are to be so designed that:

- reserve feed water is available in sufficient quantity to compensate for losses
- feed water is free from contamination by oils or chlorides
- feed water for propulsion systems is suitably de-aerated.

16.2.2 Availability

- Feed water systems are to be so designed that, in the event of failure of any one component, the steam supply to essential services can be maintained or restored.
- Condensate systems are to be so designed that, in the event of failure:
 - of one condensate pump,
 - or of the arrangements to maintain vacuum in the condenser,
 the steam supply to essential services can be maintained. Partial reduction of the propulsion capability may be accepted, however, when it is demonstrated that the safe operation of the ship is not impaired.

16.3 Design of boiler feed water systems

16.3.1 Number of feed water systems

- Every steam generating system which provides services essential for the safety of the ship, or which could be rendered dangerous by the failure of its feed water supply, is to be provided with not less than two separate feed water systems from and including the feed pumps,

noting that a single penetration of the steam drum is acceptable.

- b) The requirement stated in a) may be dispensed with for boilers heated exclusively by engine exhaust gases or by steam for which one feed system is considered as sufficient, provided an alternative supply of steam is available on board.
- c) Each boiler is to be provided with feed regulators as specified in Sec 3, [5].

16.3.2 Feed pumps

- a) The following pumps are to be provided:
 - at least one main feed pump of sufficient capacity to supply the boilers under nominal conditions,
 - and one standby feed pump.
- b) The capacity of the standby pump may be less than that of the main feed pumps provided it is demonstrated that, taking into account the reduction of the propulsion capability, the ship remains safely operable.
- c) Main feed pumps may be either independent or driven by the main turbines. The standby feed pump is to be independent.
- d) In twin-screw ships in which there is only one independent feed pump, each main turbine is to be fitted with a driven pump. Where all feed pumps are independent, they are to be so arranged as to be capable of dealing with the feed water necessary to supply steam either to both turbines or to one turbine only.
- e) Independent feed pumps for main boilers are to be fitted with a delivery control and regulating system.
- f) Unless overpressure is prevented by the feed pump characteristics, means are to be provided which will prevent overpressure in any part of the feed water system.
- g) The pressure head of feed pumps is to take into account the maximum service pressure in the boiler as well as the pressure losses in the discharge piping. The suction head of feed pumps is to be such as to prevent any risk of cavitation.
- h) Feed pumps and pipes are to be provided with valves so arranged that any one pump can be overhauled while the boilers are operating at full load.

16.3.3 Harbour feed pumps

- a) Where main turbine driven pumps are provided and there is only one independent pump, a harbour feed pump or an ejector is to be fitted in addition to provide the second means for feeding the boilers which are in use when the main turbine is not working.
- b) The harbour feed pump may be used for the general service of the ship, but in no case is this pump to be used to convey liquid fuel, lubricating oil or oily water.
- c) The suction pipes of the harbour feed pump from the hotwell, from reserve feed water tanks and from filters are to be fitted with non-return valves.

16.3.4 Feed water tanks

- a) All ships fitted with main boilers or auxiliary boilers for essential services are to be provided with reserve feed

water tanks of sufficient capacity having regard to the service of the ship.

- b) Boilers are to be provided with means to supervise and control the quality of the feed water. Suitable arrangements are to be provided to preclude, as far as practicable, the entry of oil or other contaminants which may adversely affect the boiler.
- c) Feed water tanks are not to be located adjacent to fuel oil tanks. Fuel oil pipes are not to pass through feed water tanks.
- d) For main boilers, one or more evaporators are to be provided, the capacity of which is to compensate for the losses of feed water due to the operation of the machines, in particular where the fuel supplied to the boilers is atomised by means of steam.

16.3.5 Provision for de-aerating feed water

A de-aerator is to be provided to ensure the de-aeration of the feed water intended for main boilers before it enters such boilers.

16.4 Design of condensate systems

16.4.1 Condensers

- a) Appropriate arrangements, such as air ejectors, are to be provided to maintain vacuum in the main condenser or restore it to the required value.
- b) Cooling of the main condenser is to comply with the provisions of [10.3.5].

16.4.2 Condensate pumps

- a) Condensate pumps are to include at least:
 - one main condensate pump of sufficient capacity to transfer the maximum amount of condensate produced under nominal conditions,
 - and one independently driven standby condensate pump.
- b) The standby condensate pump may be used for other purposes.

16.4.3 Condensate observation tanks

Any condensate from the steam heating pipes provided for fuel oil tanks and bunkers, cargo tanks and fuel oil or lubricating oil heaters is to be led to an observation tank or some other device of similar efficiency located in a well-lighted and readily accessible position.

16.5 Control and monitoring

16.5.1 General

In addition to those of this item [16.5], the general requirements given in Chapter 3 apply.

In the case of ships with automation notations, the requirements in Part F, Chapter 2 also apply.

16.5.2 General

The provisions of this sub-article apply only to feed water and condensate systems intended for propulsion.

16.5.3 Monitoring

Alarms and safeguards are to be provided for feed water and condensate systems in accordance with Tab 31.

Note 1: Some departures from Tab 31 may be accepted by the Society in the case of ships with a restricted navigation notation.

16.5.4 Automatic controls

Automatic level control is to be provided for:

- de-aerators,
- condensers.

16.6 Arrangement of feed water and condensate piping

16.6.1

- Feed water pipes are not to pass through fuel oil or lubricating oil tanks.
- Pipes connected to feed water tanks are to be so arranged as to prevent the contamination of feed water by fuel oil, lubricating oil or chlorides.

17 Compressed air systems

17.1 Application

17.1.1 This Article applies to compressed air systems intended for essential services, and in particular to:

- starting of engines,
- control and monitoring.

17.2 Principle

17.2.1 General

- Compressed air systems are to be so designed that the compressed air delivered to the consumers:
 - is free from oil and water,
 - does not have an excessive temperature.
- Compressed air systems are to be so designed as to prevent overpressure in any part of the systems.

17.2.2 Availability

- Compressed air systems are to be so designed that, in the event of failure of one air compressor or one air receiver intended for starting, control purposes or other essential services, the air supply to such services can be maintained.
- The compressed air system for starting main engines and auxiliary engines for essential services is to be so arranged that it is possible to ensure the initial charge of air receiver(s) without the aid of a power source outside the ship.
- Supply of compressed air to the consumers of the following installations outside machinery space is to be provided with air drying sufficient to lower the dew point to not warmer than -35°C at the actual pressure:
 - navigation
 - steering
 - propulsion
 - anchoring
 - lifesaving / escape routes.

17.3 Design of starting air systems

17.3.1 Initial charge of starting air receivers

- Where, for the purpose of [17.2.2], an emergency air compressor is fitted, its driving engine is to be capable of being started by hand-operated devices. Independent electrical starting batteries may also be accepted.
- A hand compressor may be used for the purpose of [17.2.2] only if it is capable of charging within one hour an air receiver of sufficient capacity to provide 3 consecutive starts of a propulsion engine or of an engine capable of supplying the energy required for operating one of the main compressors.

Table 31 : Boiler feed and condensate system

Symbol convention H = High, HH = High high, G = group alarm L = Low, LL = Low low, I = individual alarm X = function is required, R = remote	Monitoring		Automatic control				
			System			Auxiliary	
Identification of system parameter	Alarm	Indication	Slow-down	Shut-down	Control	Stand by Start	Stop
Sea water flow or equivalent	L						
Condenser pressure	H	local					
	HH			X			
Water level in main condenser (unless justified)	H	local					
Feed water salinity	H	local					
Feed water pump delivery pressure	L	local					
						X	
Feed water tank level	L						

17.3.2 Number and capacity of air compressors

- a) Where main and auxiliary engines are arranged for starting by compressed air, two or more air compressors are to be fitted with a total capacity sufficient to supply within one hour, the receivers being at atmospheric pressure, the quantity of air needed to satisfy the provisions of Sec 2, [3.1.1]. This capacity is to be approximately equally divided between the number of compressors fitted, excluding the emergency compressor fitted in pursuance of [17.3.1].
- b) At least one of the compressors is to be independent of the engines for which starting air is supplied and is to have a capacity of not less than 50% of the total required in a).

17.3.3 Number and capacity of air receivers

- a) Where main engines are arranged for starting by compressed air, at least two air receivers are to be fitted of approximately equal capacity and capable of being used independently.
- b) The total capacity of air receivers is to be sufficient to provide without replenishment the number of starts required in Sec 2, [3.1.1]. It is also to take into account the air delivery to other consumers, such as control systems, whistle, etc., which are connected to the air receivers.

17.3.4 Air supply for starting the emergency generating set

Starting air systems serving main or auxiliary engines may be used for starting the emergency generator under the conditions specified in Sec 2, [3.1.3].

17.4 Design of control and monitoring air systems

17.4.1 Air supply

- a) The control and monitoring air supply to essential services is to be available from two sources of a sufficient capacity to allow normal operation with one source out of service.
- b) At least one air vessel fitted with a non-return valve is to be provided for control and monitoring purposes.
- c) Pressure reduction units used in control and monitoring air systems intended for essential services are to be duplicated, unless an alternative air supply is provided.
- d) Failure of the control air supply is not to cause any sudden change of the controlled equipment which may be detrimental to the safety of the ship.

17.4.2 Pressure control

Arrangements are to be made to maintain the air pressure at a suitable value in order to ensure satisfactory operation of the installation.

17.4.3 Air treatment

In addition to the provisions of [17.8.3], arrangements are to be made to ensure cooling, filtering and drying of the air

prior to its introduction in the monitoring and control circuits.

17.5 Design of air compressors

17.5.1 Prevention of excessive temperature of discharged air

Air compressors are to be so designed that the temperature of discharged air cannot exceed 95°C. For this purpose, the air compressors are to be provided where necessary with:

- suitable cooling means
- fusible plugs or alarm devices set at a temperature not exceeding 120°.

17.5.2 Prevention of overpressure

- a) Air compressors are to be fitted with a relief valve complying with [2.5.3].
- b) Means are to be provided to prevent overpressure whenever water jackets or casings of air compressors may be subjected to dangerous overpressure due to leakage from air pressure parts.
- c) Water space casings of intermediate coolers of air compressors are to be protected against any overpressure which might occur in the event of rupture of air cooler tubes.

17.5.3 Crankcase relief valves

Air compressors having a crankcase volume of at least 0,6 m³ are to be fitted with crankcases explosion relief valves satisfying the provisions of Sec 2, [2.3.4].

17.5.4 Provision for draining

Air compressors are to be fitted with a drain valve.

17.6 Control and monitoring of compressed air systems

17.6.1 General

In addition to those of this item [17.6], the general requirements given in Chapter 3 apply.

In the case of ships with automation notations, the requirements in Part F, Chapter 2 also apply.

17.6.2 Monitoring

Alarms and safeguards are to be provided for compressed air systems in accordance with Tab 32.

Note 1: Some departures from Tab 32 may be accepted by the Society in the case of ships with a restricted navigation notation.

17.6.3 Automatic controls

Automatic pressure control is to be provided for maintaining the air pressure in the air receivers within the required limits.

17.7 Materials

17.7.1 Pipes and valve bodies in control and monitoring air systems and in other air systems intended for non-essential services may be made of plastic in accordance with the provisions of App 3.

17.8 Arrangement of compressed air piping systems

17.8.1 Prevention of overpressure

Means are to be provided to prevent overpressure in any part of compressed air systems. Suitable pressure relief arrangements are to be provided for all systems.

17.8.2 Air supply to compressors

- Provisions are to be made to reduce to a minimum the entry of oil into air pressure systems.
- Air compressors are to be located in spaces provided with sufficient ventilation.

17.8.3 Air treatment and draining

- Provisions are to be made to drain air pressure systems.
- Efficient oil and water separators, or filters, are to be provided on the discharge of compressors, and drains are to be installed on compressed air pipes wherever deemed necessary.

17.8.4 Lines between compressors, receivers and engines

All discharge pipes from starting air compressors are to be lead directly to the starting air receivers, and all starting air pipes from the air receivers to main or auxiliary engines are to be entirely separate from the compressor discharge pipe system.

17.8.5 Protective devices for starting air mains

Non-return valves and other safety devices are to be provided on the starting air mains of each engine in accordance with the provisions of Sec 2, [3.1.1].

18 Exhaust gas systems

18.1 General

18.1.1 Application

This Article applies to:

- exhaust gas pipes from engines
- smoke ducts from boilers and incinerators.

18.1.2 Principle

Exhaust gas systems are to be so designed as to:

- limit the risk of fire
- prevent gases from entering manned spaces
- prevent water from entering engines.

18.2 Design of exhaust systems

18.2.1 General

Exhaust systems are to be so arranged as to minimise the intake of exhaust gases into manned spaces, air conditioning systems and engine intakes.

18.2.2 Limitation of exhaust line surface temperature

- Exhaust gas pipes and silencers are to be either water cooled or efficiently insulated where:
 - their surface temperature may exceed 220°C, or
 - they pass through spaces of the ship where a temperature rise may be dangerous.
- The insulation of exhaust systems is to comply with the provisions of Sec 1, [3.11.1].

18.2.3 Limitation of pressure losses

Exhaust gas systems are to be so designed that pressure losses in the exhaust lines do not exceed the maximum values permitted by the engine or boiler manufacturers.

Table 32 : Compressed air systems

Symbol convention H = High, HH = High high, G = group alarm L = Low, LL = Low low, I = individual alarm X = function is required, R = remote	Monitoring		Automatic control				
			System			Auxiliary	
Identification of system parameter	Alarm	Indication	Slow-down	Shut-down	Control	Stand by Start	Stop
Compressor lubricating oil pressure (except where splash lubrication)	L						
Air pressure after reducing valves	L+H	local					
Starting air pressure before main shut-off valve	L	local + R (1)					
Air vessel pressure	L+H						

(1) Remote indication is required if starting of air compressor are remote controlled, from wheelhouse for example

18.2.4 Intercommunication of engine exhaust gas lines or boiler smoke ducts

- a) Exhaust gas from different engines is not to be led to a common exhaust main, exhaust gas boiler or economiser, unless each exhaust pipe is provided with a suitable isolating device.
- b) Smoke ducts from boilers discharging to a common funnel are to be separated to a height sufficient to prevent smoke passing from a boiler which is operating to a boiler out of action.

18.2.5 Exhaust gas pipe terminations

- a) Where exhaust pipes are led overboard close to the load waterline, means are to be provided to prevent water from entering the engine or the ship.
- b) Where exhaust pipes are water cooled, they are to be so arranged as to be self-draining overboard.

18.2.6 Control and monitoring

A high temperature alarm is to be provided in the exhaust gas manifolds of thermal oil heaters to detect any outbreak of fire.

18.3 Materials

18.3.1 General

Materials of exhaust gas pipes and fittings are to be resistant to exhaust gases and suitable for the maximum temperature expected.

18.3.2 Use of plastics

The use of non-metallic materials may be accepted in water cooled systems in accordance with the provisions of App 3.

18.4 Arrangement of exhaust piping systems

18.4.1 Provision for thermal expansion

- a) Exhaust pipes and smoke ducts are to be so designed that any expansion or contraction does not cause abnormal stresses in the piping system, and in particular in the connection with engine turboblowers.
- b) The devices used for supporting the pipes are to allow their expansion or contraction.

18.4.2 Provision for draining

- a) Drains are to be provided where necessary in exhaust systems, and in particular in exhaust ducting below exhaust gas boilers, in order to prevent water flowing into the engine.
- b) Where exhaust pipes are water cooled, they are to be so arranged as to be self-draining overboard.

18.4.3 Flexible hoses

The use of flexible hoses in water cooled exhaust systems will be given special consideration by the Society.

18.4.4 Silencers

Engine silencers are to be so arranged as to provide easy access for cleaning and overhaul.

19 Oxyacetylene welding systems

19.1 Application

19.1.1 This Article applies to centralised fixed plants for oxyacetylene welding installed on ships. It may also be applied, at the discretion of the Society, to other plants using liquefied gas, such as propane.

19.2 Definitions

19.2.1 Centralised plants for oxyacetylene welding

A centralised plant for oxyacetylene welding is a fixed plant consisting of a gas bottle room or other storage arrangement (see [19.4.1]), distribution stations and distribution piping, where the total number of acetylene and oxygen bottles exceeds 4.

19.2.2 Acetylene

Acetylene (C_2H_2) is assumed to be contained in pressurised gas bottles with pressure equal to 1,5-1,8 MPa at 15°C.

19.2.3 Oxygen

Oxygen (O_2) is assumed to be contained in pressurized gas bottles, with pressure equal to 15-20 MPa at 15°C.

19.2.4 Gas bottle rooms

A gas bottle room is a room containing acetylene and oxygen bottles, where distribution headers, non-return and stop valves, pressure reducing devices and outlets of supply lines to distribution stations are also installed.

19.2.5 Distribution stations

Distribution stations are adequately protected areas or cabinets equipped with stop valves, pressure regulating devices, pressure gauges, non-return valves and oxygen as well as acetylene hose connections for the welding torch.

19.3 Design of oxyacetylene welding systems

19.3.1 General

Except on pontoons and service working ships, no more than two distribution stations are normally permitted.

19.3.2 Acetylene and oxygen bottles

- a) The bottles are to be tested by the Society or by a body recognised by the Society.
- b) Bottles with a capacity exceeding 50 litres are not permitted.
- c) Bottles supplying the plant and spare bottles are to be installed in the gas bottle room. Installation within accommodation spaces, service spaces, control stations and machinery spaces is not permitted.
- d) Bottles are to be installed in a vertical position and are to be safely secured. The securing system is to be such as to allow the ready and easy removal of the bottles.

19.3.3 Piping systems

- a) Acetylene and oxygen piping systems are to comply with the following provisions:
 - all valves and fittings as well as welding torches and associated supply hoses are to be adapted to this

- specific service and suitable for the conditions expected in the different parts of the system
- the connections between the various pipe sections are to be carried out by means of butt welding. Other types of connections including threaded connections and flange connections are not permitted.
 - only a minimum number of unavoidable connections are permitted provided they are located in a clearly visible position.
- b) High pressure lines (i.e. lines between bottles and pressure reducing devices) are to be installed inside the gas bottle room and are to comply with the following provisions:
- acetylene piping is to be of stainless steel and seamless drawn
 - oxygen piping is to be of copper or stainless steel and seamless drawn
 - acetylene and oxygen piping and associated fittings are to be suitable for a design pressure of 29,5 MPa
 - a non-return valve is to be installed on the connection of each acetylene and oxygen bottle to the header
 - stop valves are to be provided on the bottles and kept shut when distribution stations are not working.
- c) Low pressure lines (i.e. lines between pressure reducing devices and distribution stations) are to comply with the following provisions:
- pipes are to be of seamless steel
 - piping is to have a thickness of not less than:
 - 2,5 mm when installed in the open air,
 - 2 mm otherwise.
 - supply lines to each distribution station are to include, at the station inlet:
 - a stop valve to be kept shut when the station is not working,
 - devices to protect the supply lines from back flow of gas or flame passage.
- d) Safety valves are to be provided on the low pressure side of the pressure reducing devices and led to the open air at least 3 m above the deck in a safe location where no source of ignition is present.

19.4 Arrangement of oxyacetylene welding systems

19.4.1 Gas bottle rooms

- a) The gas bottle room is to be located in an independent space over the highest continuous deck and provided with direct access from outside. The limiting bulkheads and decks are to be made of steel. The limiting bulkheads and decks between the room and other enclosed spaces are to be gas-tight.
- b) When the total number of gas bottles, including possible spare bottles which are not connected to the plant, does not exceed 8, acetylene and oxygen bottles may

be installed in the same room. Otherwise, acetylene and oxygen bottles are to be separated by a gas-tight bulkhead.

- c) The bottle room is to be adequately insulated and fitted with ventilation systems capable of providing at least six air changes per hour based on the gross volume of the room. The ventilation system is to be independent of ventilation systems of other spaces. The space within 3 m from the mechanical ventilation exhaust or 1 m from the natural ventilation exhaust is to be considered a hazardous area. The fan is to be of non-sparking construction. Small storage spaces provided with sufficiently large openings for natural ventilation need not be fitted with mechanical ventilation.

Electrical equipment installed within the storage room, including the ventilation fan motor, is to be of the certified safe type.

Where no storage room is provided, the gas cylinders may be placed in an open storage area. In such cases they are to be shaded from heat sources and protected against mechanical, weather and sea damage.

- d) The gas bottle room is not to be used for other services on board. Flammable oil or gas piping, except that related to the oxyacetylene welding plant, is not to be led through this room.

Note 1: On pontoons and service working ships, gas bottles may be installed on open deck in a safe position to the satisfaction of the Society. In such case, appropriate protection is to be provided:

- for gas bottles, against sunrays and atmospheric agents, by means of watertight covers,
- for the associated valves, piping and fittings, by means of steel covers, metal grids or similar devices.

Such means of protection are to be easily removable to allow bottle removal, when necessary.

When the total number of bottles exceeds 8, acetylene bottles are to be separated from oxygen bottles.

19.4.2 Distribution stations

Distribution stations are to be located in the engine room or in the workshop, in a well-ventilated position and protected against possible mechanical damage.

Note 1: On pontoons and service working ships, distribution stations may be installed in the open air, enclosed in a cabinet with a locked door, or in controlled access areas, to the satisfaction of the Society.

19.4.3 Piping

- a) Piping is not to be led through accommodation or service spaces.
- b) Piping is to be protected against any possible mechanical damage.
- c) In way of deck or bulkhead penetrations, piping is to be suitably enclosed in sleeves so arranged as to prevent any fretting of the pipe with the sleeve.

19.4.4 Signboards

Signboards are to be posted on board the ship in accordance with Tab 33.

Table 33 : Signboards

Location of the signboard	Signboard to be posted
in the gas bottle room	diagram of the oxyacetylene plant
	"no smoking"
in way of: <ul style="list-style-type: none"> bottle stop valves distribution station stop valves 	"to be kept shut when distribution stations are not working"
in way of the pressure reducing devices	indication of the maximum allowable pressure at the pressure reducing device outlet
in way of the safety valve discharge outlet	"no smoking"

20 Certification, inspection and testing of piping systems

20.1 Application

20.1.1 This Article defines the certification and workshop inspection and testing programme to be performed on:

- the various components of piping systems,
- the materials used for their manufacture.

On board testing is dealt with in Sec 15.

20.2 Type tests

20.2.1 Type tests of flexible hoses and expansion joints

- Type approval tests are to be carried out on flexible hoses or expansion joints of each type and of sizes to be agreed with the Society, in accordance with Tab 34 (see also the "Rules for the type approval of flexible hoses and expansion joints").
- The flexible hoses or expansion joints subjected to the tests are to be fitted with their connections.

20.2.2 Type tests of air pipe closing devices

Type approval tests are to be carried out on each type and size of air pipe closing device, in accordance with Tab 35 and the "Rules for type approval and testing of air pipe closing devices".

20.3 Testing of materials

20.3.1 General

- Detailed specifications for material tests are given in Part D.
- Requirements for the inspection of welded joints are given in Part D.
- The requirements of this Article do not apply to piping systems subjected to low temperatures.

Table 34 : Type tests to be performed for flexible hoses and expansion joints

Test	Flexible hoses and expansion joints in non-metallic material	Flexible hoses and expansion joints in metallic material
bursting test	X	X
fire-resistance test	X (1)	NR
vibration test (2)	X	X
pressure impulse test	X (6)	NR
flexibility test	X (3)	NR
elastic deformation test	NR	X
cyclic expansion test (4)	NR	X
resistance of the material (5)	X	X

(1) only for flexible hoses and expansion joints used in flammable oil systems and, when required, in sea water systems.
(2) the Society reserves the right to require the vibration test in case of installation of the components on sources of high vibrations.
(3) only for flexible hoses conveying low temperature fluids.
(4) the Society reserves the right to require the cyclic expansion test for piping systems subjected to expansion cycles
(5) internal to the conveyed fluid to be demonstrated by suitable documentation and / or tests.
(6) only for flexible hoses.
Note 1: X = required, NR = not required.

Table 35 : Type tests to be performed for air pipe closing appliances

Test to be performed	Type of air closing appliance	
	Float type	Other types
tightness test (1)	X	X
flow characteristic determination (2)	X	X
impact test of floats	X	
pressure loading test of floats	X (3)	

(1) the tightness test is to be carried out during immersing/emerging in water, in the normal position and at an inclination of 40 degrees.
(2) pressure drop is to be measured versus flow rate using water.
(3) only for non-metallic floats.
Note 1: X = required

20.3.2 Tests for materials

- Where required in Tab 36, materials used for pipes, valves and other accessories are to be subjected to the following tests:
 - tensile test at ambient temperature
 - flattening test or bend test, as applicable

- tensile test at the design temperature, except if one of the following conditions is met:
 - the design temperature is below 200°C
 - the mechanical properties of the material at high temperature have been approved
 - the scantling of the pipes is based on reduced values of the permissible stress.
- b) Plastic materials are to be subjected to the tests specified in App 3.

20.4 Hydrostatic testing of piping systems and their components

20.4.1 General

Pneumatic tests are to be avoided wherever possible. Where such testing is absolutely necessary in lieu of the hydraulic pressure test, the relevant procedure is to be submitted to the Society for acceptance prior to testing.

20.4.2 Hydrostatic pressure tests of piping

- a) Hydrostatic pressure tests are to be carried out to the Surveyor's satisfaction for:
 - all class I and II pipes and their integral fittings
 - all steam pipes, feed water pipes, compressed air pipes, and fuel oil and other flammable oil pipes with a design pressure greater than 0,35 MPa and their associated integral fittings.
- b) These tests are to be carried out after completion of manufacture and before installation on board and, where applicable, before insulating and coating.

Note 1: Classes of pipes are defined in [1.5.2].

- c) Pressure testing of small bore pipes (less than 15 mm) may be waived at the discretion of the Surveyor, depending on the application.
- d) Where the design temperature does not exceed 300°C, the test pressure is to be equal to 1,5 p.
- e) Where the design temperature exceeds 300°C, the test pressure is to be as follows:

$$p_H = 1,5 \frac{K_{100}}{K_T} p$$

where:

K_{100} : permissible stress for 100°C, as stated in Tab 10

K_T : permissible stress for the design temperature, as stated in Tab 10.

Note 2: Where alloy steels not included in Tab 10 are used, the permissible stresses will be given special consideration.

- f) Where it is necessary to avoid excessive stress in way of bends, branches, etc., the Society may give special consideration to the reduction of the test pressure to a value not less than 1,5 p. The membrane stress is in no case to

exceed 90% of the yield stress at the testing temperature.

- g) While satisfying the condition stated in b), the test pressure of pipes located on the discharge side of centrifugal pumps driven by steam turbines is not to be less than the maximum pressure liable to be developed by such pumps with closed discharge at the operating speed of their overspeed device.
- h) When the hydrostatic test of piping is carried out on board, these tests may be carried out in conjunction with the tests required in [20.4.7]

20.4.3 Hydrostatic tests of valves, fittings and heat exchangers

- a) Valves and fittings non-integral with the piping system and intended for class I and II pipes are to be subjected to hydrostatic tests in accordance with standards recognised by the Society, at a pressure not less than 1,5 times the design pressure p defined in [1.3.2].
- b) Valves intended to be fitted on the ship side below the load waterline are to be subjected to hydrostatic tests under a pressure not less than 0,5 MPa.
- c) The shells of appliances such as heaters, coolers and heat exchangers which may be considered as pressure vessels are to be tested under the conditions specified in Sec 3.
- d) The nests of tubes or coils of heaters, coolers and heat exchangers are to be submitted to a hydraulic test under the same pressure as the fluid lines they serve.
- e) For coolers of internal combustion engines, see Sec 2.

20.4.4 Hydrostatic tests of fuel oil bunkers and tanks not forming part of the ship's structure

Fuel oil bunkers and tanks not forming part of the ship's structure are to be subjected to a hydrostatic test under a pressure corresponding to the maximum liquid level in such spaces or in the air or overflow pipes, with a minimum of 2,40 m above the top. The minimum height is to be 3,60 m for tanks intended to contain fuel oil with a flashpoint below 60°C.

20.4.5 Hydrostatic tests of pumps and compressors

- a) Cylinders, covers and casings of pumps and compressors are to be subjected to a hydrostatic test under a pressure at least equal to the pressure p_H determined by the following formulae:

- $p_H = 1,5 p$ where $p \leq 4$
- $p_H = 1,4 p + 0,4$ where $4 < p \leq 25$
- $p_H = p + 10,4$ where $p > 25$

where

- p_H : test pressure, in MPa
- p : design pressure, as defined in [1.3.2], in MPa.

p_H is not to be less than 0,4 MPa.

- b) While satisfying the condition stated in a), the test pressure for centrifugal pumps driven by steam turbines is not to be less than 1,05 times the maximum pressure

likely to be recorded with closed discharge at the operating speed of the overspeed device.

- c) Intermediate coolers of compressors are to undergo a hydrostatic test under a pressure at least equal to the pressure p_H defined in a). When determining p_H , the pressure p to be considered is that which may result from accidental communication between the cooler and the adjoining stage of higher pressure, allowance being made for any safety device fitted on the cooler.
- d) The test pressure for water spaces of compressors and their intermediate coolers is not to be less than 1,5 times the design pressure in the space concerned, subject to a minimum of 0,2 MPa.
- e) For air compressors and pumps driven by diesel engines, see Sec 2.

20.4.6 Hydrostatic test of flexible hoses and expansion joints

- a) Each flexible hose or expansion joint, together with its connections, is to undergo a hydrostatic test under a pressure at least equal to 1,5 times the maximum service pressure.
- b) During the test, the flexible hose or expansion joint is to be repeatedly deformed from its geometrical axis.

20.4.7 Pressure tests of piping after assembly on board

After assembly on board, the following tightness tests are to be carried out in the presence of the Surveyor.

In general, all the piping systems covered by these requirements are to be checked for leakage under operational conditions and, if necessary, using special techniques other than hydrostatic testing. In particular, heating coils in tanks and liquid or gas fuel lines are to be tested to not less than 1,5 times the design pressure but in no case less than 0,4 MPa.

20.5 Testing of piping system components during manufacturing

20.5.1 Pumps

- a) Bilge and fire pumps are to undergo a performance test.
- b) Rotors of centrifugal feed pumps for main boilers are to undergo a balancing test.

20.5.2 Centrifugal separators

Centrifugal separators used for fuel oil and lubricating oil are to undergo a running test, normally with a fuel water mixture.

20.6 Inspection and testing of piping systems

20.6.1 The inspections and tests required for piping systems and their components are summarised in Tab 36.

Table 36 : Inspection and testing at works for piping systems and their components

No.	Item	Tests for materials (1)		Inspections and tests for the product (1)			Reference to the Rules
		Tests required	Type of material certificate (2)	During manufacturing (NDT)	After completion	Type of product certificate	
1	Valves, pipes and fittings a) class I, $d \geq 32$ mm or class II, $d \geq 100$ mm	X	C	X (5)	X	C (3)	[20.3.2] [3.6.2] [3.6.3] [20.4.3]; Pt D, Ch 2, Sec 2, [1.8]
	b) class I, $d < 32$ mm or class II, $d < 100$ mm	X	W	X (5)	X	C (3)	[20.3.2] [3.6.2] [3.6.3] [20.4.3]; Pt D, Ch 2, Sec 2, [1.8]
	c) class III	X	W		X	W	[20.3.2]
2	Flexible hoses and expansion joints	X (6)	W		X	C (3)	[20.3.2] [20.4.6]
3	Pumps and compressors a) all	X	W		X	C (3)	[20.4.5]
	b) bilge and fire pumps	X	W		X	C (3)	[20.5.1]
	c) feed pumps for main boilers: • casing and bolts • main parts • rotor	X	C	X	X	C (3)	Part D Part D [20.5.1]
	d) forced circulation pumps for main boiler: • casing and bolts	X	C			C (3)	Part D
4	Centrifugal separators				X	C (3)	[20.5.2]
5	Prefabricated pipe lines a) class I and II with: • $d \geq 75$ mm, or • $t \geq 10$ mm			X (7)	X	C (3)	[3.6.2] [3.6.3] [20.4.2]
	b) class I and II with: • $d < 75$ mm, and • $t < 10$ mm			X (7)	X	W	[3.6.2] [3.6.3] [20.4.2]
	c) class III (4)				X	W	[20.4.2]
<p>(1) X = test is required (2) C = class certificate W = works' certificate (3) or alternative type of certificate, depending on the Inspection Scheme. See Part D. (4) where required by [20.4.2]. (5) if of welded construction. (6) if metallic. (7) for welded connections.</p>							

SECTION 9 STEERING GEAR

1 General

1.1 Application

1.1.1 Scope

Unless otherwise specified, the requirements of this Section apply to the steering gear systems of all mechanically propelled ships, and to the steering mechanism of thrusters used as means of propulsion.

1.1.2 Cross references

In addition to the those provided in this Section, steering gear systems are also to comply with the requirements of:

- Sec 13, as regards sea trials
- Pt B, Ch 10, Sec 1, as regards the rudder and the rudder stock
- Pt E, Ch 1, Sec 4, [7], when fitted to oil tankers.

1.2 Documentation to be submitted

1.2.1 Documents to be submitted for all steering gear

Before starting construction, all plans and specifications listed in Tab 1 are to be submitted to the Society for approval.

Table 1 : Documents to be submitted for steering gear

No.	I / A (2)	Document (1)
1	I	Assembly drawing of the steering gear including sliding blocks, guides, stops and other similar components
2	I	General description of the installation and of its functioning principle
3	I	Operating manuals of the steering gear and of its main components
4	I	Description of the operational modes intended for steering in normal and emergency conditions
5	A	For hydraulic steering gear, the schematic layout of the hydraulic piping of power actuating systems, including the hydraulic fluid refilling system, with indication of: <ul style="list-style-type: none"> • the design pressure • the maximum working pressure expected in service • the diameter, thickness, material specification and connection details of the pipes • the hydraulic fluid tank capacity • the flashpoint of the hydraulic fluid
6	I	For hydraulic pumps of power units, the assembly longitudinal and transverse sectional drawings and the characteristic curves
7	A	Assembly drawings of the rudder actuators and constructional drawings of their components, with, for hydraulic actuators, indication of: <ul style="list-style-type: none"> • the design torque • the maximum working pressure • the relief valve setting pressure
8	I	Constructional drawings of the relief valves for protection of the hydraulic actuators, with indication of: <ul style="list-style-type: none"> • the setting pressure • the relieving capacity
9	A	Diagrams of the electric power circuits
10	A	Functional diagram of control, monitoring and safety systems including the remote control from the navigating bridge, with indication of the location of control, monitoring and safety devices
11	A	Constructional drawings of the strength parts providing a mechanical transmission of forces to the rudder stock (tiller, quadrant, connecting rods and other similar items), with the calculation notes of the shrink-fit connections
12	I/A	For azimuth thrusters used as steering means, the specification and drawings of the steering mechanism and, where applicable, documents 2 to 6 and 8 to 11 above
<p>(1) Constructional drawings are to be accompanied by the specification of the materials employed and, where applicable, by the welding details and welding procedures.</p> <p>(2) A = to be submitted for approval in four copies I = to be submitted for information in duplicate.</p>		

1.2.2 Additional documents

The following additional documents are to be submitted:

- analysis in relation to the risk of single failure, where required by [3.5.2]
- analysis in relation to the risk of hydraulic locking, where required by [3.5.5]
- failure analysis in relation to the availability of the hydraulic power supply, where required by [4.5.3], item b)
- fatigue analysis and/or fracture mechanics analysis, where required by Pt E, Ch 1, Sec 4, [7].

1.3 Definitions

1.3.1 Main steering gear

Main steering gear is the machinery, rudder actuators, steering gear power units, if any, and ancillary equipment and the means of applying torque to the rudder stock (e.g. tiller or quadrant) necessary for effecting movement of the rudder for the purpose of steering the ship under normal service conditions.

1.3.2 Steering gear power unit

Steering gear power unit is:

- in the case of electric steering gear, an electric motor and its associated electrical equipment
- in the case of electrohydraulic steering gear, an electric motor and its associated electrical equipment and connected pump
- in the case of other hydraulic steering gear, a driving engine and connected pump.

1.3.3 Auxiliary steering gear

Auxiliary steering gear is the equipment other than any part of the main steering gear necessary to steer the ship in the event of failure of the main steering gear but not including the tiller, quadrant or components serving the same purpose.

1.3.4 Power actuating system

Power actuating system is the hydraulic equipment provided for supplying power to turn the rudder stock, comprising a steering gear power unit or units, together with the associated pipes and fittings, and a rudder actuator. The power actuating systems may share common mechanical components, i.e. tiller, quadrant and rudder stock, or components serving the same purpose.

1.3.5 Rudder actuator

Rudder actuator is the component which directly converts hydraulic pressure into mechanical action to move the rudder.

1.3.6 Steering gear control system

Steering gear control system is the equipment by which orders are transmitted from the navigation bridge to the steering gear power units. Steering gear control systems comprise transmitters, receivers, hydraulic control pumps and their associated motors, motor controllers, piping and cables.

1.3.7 Maximum ahead service speed

Maximum ahead service speed is the greatest speed which the ship is designed to maintain in service at sea at the deepest seagoing draught.

1.3.8 Maximum astern speed

Maximum astern speed is the speed which it is estimated the ship can attain at the designed maximum astern power at the deepest seagoing draught.

1.3.9 Maximum working pressure

Maximum working pressure is the maximum expected pressure in the system when the steering gear is operated to comply with the provisions of [3.3.1], item b), or [4.3.1], item b).

1.4 Symbols

1.4.1 The following symbols are used for strength criteria of steering gear components:

V : Maximum service speed, in knots, with the ship on summer load waterline. When the speed is less than 10 knots, V is to be replaced by the value $(V+20)/3$

d_s : Rule diameter of the rudder stock in way of the tiller, in mm, as defined in Pt B, Ch 10, Sec 1

d_{se} : Actual diameter of the upper part of the rudder stock in way of the tiller, in mm
(in the case of a tapered coupling, this diameter is measured at the base of the assembly)

T_R : Rule design torque of the rudder stock given, in kN.m, by the following formula:

$$T_R = 13,5 \cdot d_s^3 \cdot 10^{-6}$$

T_E : For hand emergency operation, design torque due to forces induced by the rudder, in kN.m, given by the following formula:

$$T_E = 0,62 \cdot \left(\frac{V_E + 2}{V + 2} \right)^2 \cdot T_R$$

where:

- $V_E = 7$, where $V \leq 14$
- $V_E = 0,5 V$, where $V > 14$

T_G : For main hydraulic or electrohydraulic steering gear, torque induced by the main steering gear on the rudder stock when the pressure is equal to the setting pressure of the relief valves protecting the rudder actuators

Note 1: for hand-operated main steering gear, the following value is to be used:

$$T_G = 1,25 \cdot T_R$$

T_A : For auxiliary hydraulic or electrohydraulic steering gear, torque induced by the auxiliary steering gear on the rudder stock when the pressure is equal to the setting pressure of the relief valves protecting the rudder actuators

Note 2: for hand-operated auxiliary steering gear, the following value is to be used:

$$T_A = 1,25 \cdot T_E$$

- T'_G : For steering gear which can activate the rudder with a reduced number of actuators, the value of T_G in such conditions
- σ : Normal stress due to the bending moments and the tensile and compressive forces, in N/mm²
- τ : Tangential stress due to the torsional moment and the shear forces, in N/mm²
- σ_a : Permissible stress, in N/mm²
- σ_c : Combined stress, determined by the following formula:
- $$\sigma_c = \sqrt{\sigma^2 + 3\tau^2}$$
- R : Value of the minimum specified tensile strength of the material at ambient temperature, in N/mm²
- R_e : Value of the minimum specified yield strength of the material at ambient temperature, in N/mm²
- R'_e : Design yield strength, in N/mm², determined by the following formulae:
- $R'_e = R_e$, where $R \geq 1,4 R_e$
 - $R'_e = 0,417 (R_e + R)$ where $R < 1,4 R_e$

2 Design and construction - Requirements applicable to all ships

2.1 Mechanical components

2.1.1 General

- a) All steering gear components and the rudder stock are to be of sound and reliable construction to the satisfaction of the Society.
- b) Any non-duplicated essential component is, where appropriate, to utilise anti-friction bearings, such as ball bearings, roller bearings or sleeve bearings, which are to

be permanently lubricated or provided with lubrication fittings.

- c) The construction is to be such as to minimise local concentration of stress.
- d) All steering gear components transmitting mechanical forces to the rudder stock, which are not protected against overload by structural rudder stops or mechanical buffers, are to have a strength at least equivalent to that of the rudder stock in way of the tiller.

2.1.2 Materials and welds

- a) All steering gear components transmitting mechanical forces to the rudder stock (such as tillers, quadrants, or similar components) are to be of steel or other approved ductile material complying with the requirements of Part D. In general, such material is to have an elongation of not less than 12% and a tensile strength not greater than 650 N/mm².
- b) The use of grey cast iron is not permitted, except for redundant parts with low stress level, subject to special consideration by the Society. It is not permitted for cylinders.
- c) The welding details and welding procedures are to be submitted for approval.
- d) All welded joints within the pressure boundary of a rudder actuator or connecting parts transmitting mechanical loads are to be full penetration type or of equivalent strength.

2.1.3 Scantling of components

The scantling of steering gear components is to be determined considering the design torque M_T and the permissible value σ_a of the combined stress, as given in:

- Tab 2 for components which are protected against overloads induced by the rudder
- Tab 3 for components which are not protected against overloads induced by the rudder.

Table 2 : Scantling of components protected against overloads induced by the rudder

Conditions of use of the components	M_T	σ_a
Normal operation	T_G	<ul style="list-style-type: none"> • if $T_G \leq 1,25 T_R$: $\sigma_a = 1,25 \sigma_0$ • if $1,25 T_R < T_G < 1,50 T_R$: $\sigma_a = \sigma_0 T_G/T_R$ • if $T_G \geq 1,50 T_R$: $\sigma_a = 1,50 \sigma_0$ where $\sigma_0 = 0,55 R'_e$
Normal operation, with a reduced number of actuators	T'_G	<ul style="list-style-type: none"> • if $T'_G \leq 1,25 T_R$: $\sigma_a = 1,25 \sigma_0$ • if $1,25 T_R < T'_G < 1,50 T_R$: $\sigma_a = \sigma_0 T'_G/T_R$ • if $T'_G \geq 1,50 T_R$: $\sigma_a = 1,50 \sigma_0$ where $\sigma_0 = 0,55 R'_e$
Emergency operation achieved by hydraulic or electrohydraulic steering gear	lower of T_R and $0,8 T_A$	$0,69 R'_e$
Emergency operation, with a reduced number of actuators	lower of T_R and $0,8 T'_G$	$0,69 R'_e$
Emergency operation achieved by hand	T_E	$0,69 R'_e$

Table 3 : Scantling of components not protected against overloads induced by the rudder

Conditions of use of the components	M_T	σ_a
Normal operation	T_R	$0,55 R'_e$
Normal operation, with a reduced number of actuators	lower of T_R and $0,8 T'_G$	$0,55 R'_e$
Emergency operation achieved by hydraulic or electrohydraulic steering gear	lower of T_R and $0,8 T_A$	$0,69 R'_e$
Emergency operation, with a reduced number of actuators	lower of T_R and $0,8 T'_G$	$0,69 R'_e$
Emergency operation achieved by hand	T_E	$0,69 R'_e$

2.1.4 Tillers, quadrants and rotors

a) The scantling of the tiller is to be determined as follows:

- the depth H_0 of the boss is not to be less than d_s
- the radial thickness of the boss in way of the tiller is not to be less than $0,4 \cdot d_s$
- the section modulus of the tiller arm in way of the end fixed to the boss is not to be less than the value Z_b , in cm^3 , calculated from the following formula:

$$Z_b = \frac{0,147 \cdot d_s \cdot L'}{1000} \cdot \frac{R_e}{R'_e}$$

where:

L : Distance from the centreline of the rudder stock to the point of application of the load on the tiller (see Fig 1)

L' : Distance between the point of application of the above load and the root section of the tiller arm under consideration (see Fig 1)

- the width and thickness of the tiller arm in way of the point of application of the load are not to be less than one half of those required by the above formula
- in the case of double arm tillers, the section modulus of each arm is not to be less than one half of the section modulus required by the above formula.

Figure 1 : Tiller arm

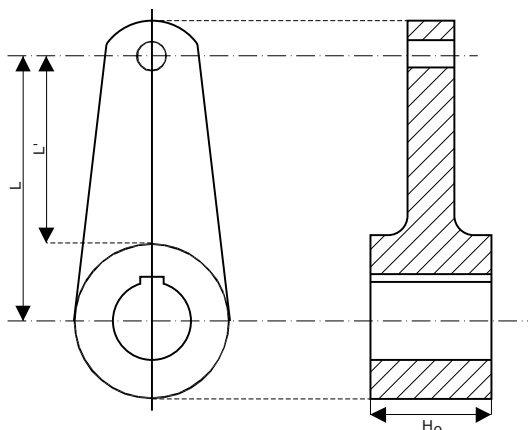

b) The scantling of the quadrants is to be determined as specified in a) for the tillers. When quadrants having two or three arms are provided, the section modulus of each arm is not to be less than one half or one third, respectively, of the section modulus required for the tiller.

Arms of loose quadrants not keyed to the rudder stock may be of reduced dimensions to the satisfaction of the Society, and the depth of the boss may be reduced by 10 per cent.

c) Keys are to satisfy the following provisions:

- the key is to be made of steel with a yield stress not less than that of the rudder stock and that of the tiller boss or rotor without being less than 235 N/mm^2
- the width of the key is not to be less than $0,25 \cdot d_s$
- the thickness of the key is not to be less than $0,10 \cdot d_s$
- the ends of the keyways in the rudder stock and in the tiller (or rotor) are to be rounded and the keyway root fillets are to be provided with small radii of not less than 5 per cent of the key thickness.

d) Bolted tillers and quadrants are to satisfy the following provisions:

- the diameter of the bolts is not to be less than the value d_b , in mm, calculated from the following formula:

$$d_b = 153 \sqrt{\frac{T_R}{n(b + 0,5 d_{se})} \cdot \frac{235}{R_{eb}}}$$

where:

n : Number of bolts located on the same side in respect of the stock axis (n is not to be less than 2)

b : Distance between bolts and stock axis, in mm (see Fig 2)

R_{eb} : Yield stress, in N/mm^2 , of the bolt material

- the thickness of the coupling flanges is not to be less than the diameter of the bolts
- in order to ensure the efficient tightening of the coupling around the stock, the two parts of the tiller are to be bored together with a shim having a thickness not less than the value j , in mm, calculated from the following formula:

$$j = 0,0015 \cdot d_s$$

Figure 2 : Bolted tillers

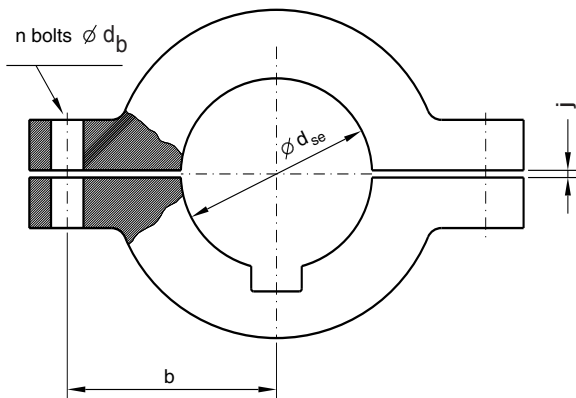

e) Shrink-fit connections of tiller (or rotor) to stock are to satisfy the following provisions:

- the safety factor against slippage is not to be less than:
 - 1 for keyed connections
 - 2 for keyless connections
- the friction coefficient is to be taken equal to:
 - 0,15 for steel and 0,13 for spheroidal graphite cast iron, in the case of hydraulic fit
 - 0,17 in the case of dry shrink fitting
- the combined stress according to the von Mises criterion, due to the maximum pressure induced by the shrink fitting and calculated in way of the most stressed points of the shrunk parts, is not to exceed 80 per cent of the yield stress of the material considered

Note 1: Alternative stress values based on FEM calculations may also be considered by the Society.

- the entrance edge of the tiller bore and that of the rudder stock cone are to be rounded or bevelled.

2.1.5 Piston rods

The scantling of the piston rod is to be determined taking into account the bending moments, if any, in addition to compressive or traction forces and is to satisfy the following provisions:

a) $\sigma_c \leq \sigma_a$

where:

σ_c : Combined stress as per [1.4.1]

σ_a : Permissible stress as per [2.1.3]

b) in respect of the buckling strength:

$$\frac{4}{\pi D_2^2} \cdot \left(\omega F_c + \frac{8M}{D_2} \right) \leq 0,9 \sigma_a$$

where:

D_2 : Piston rod diameter, in mm

F_c : Compression force in the rod, in N, when it extends to its maximum stroke

M : Possible bending moment in the piston rod, in N.mm, in way of the fore end of the cylinder rod bearing

ω : $= \alpha + (\beta^2 - \alpha)^{0,5}$

with:

$$\alpha = 0,0072 (l_s/d_s)^2 \cdot R'_d / 235,$$

$$\beta = 0,48 + 0,5 \alpha + 0,1 \alpha^{0,5},$$

l_s = Length, in mm, of the maximum unsupported reach of the cylinder rod.

2.2 Hydraulic system

2.2.1 General

a) The design pressure for calculations to determine the scantlings of piping and other steering gear components subjected to internal hydraulic pressure shall be at least 1,25 times the maximum working pressure to be expected under the operational conditions specified in [3] and [4], taking into account any pressure which may exist in the low pressure side of the system.

At the discretion of the Society, high cycle and cumulative fatigue analysis may be required for the design of piping and components, taking into account pulsating pressures due to dynamic loads.

b) The power piping for hydraulic steering gear is to be arranged so that transfer between units can be readily effected.

c) Arrangements for bleeding air from the hydraulic system are to be provided, where necessary.

The hydraulic piping system, including joints, valves, flanges and other fittings, is to comply with the requirements of Sec 10 for class I piping systems, and in particular with the requirements of Sec 10, [14], unless otherwise stated.

2.2.2 Materials

a) Ram cylinders, pressure housings of rotary vane type actuators, hydraulic power piping, valves, flanges and fittings are to be of steel or other approved ductile material.

b) In general, such material is to have an elongation of not less than 12% and a tensile strength not greater than 650 N/mm².

Grey cast iron may be accepted for valve bodies and redundant parts with low stress level, excluding cylinders, subject to special consideration.

2.2.3 Isolating valves

Shut-off valves, non-return valves or other appropriate devices are to be provided:

- to comply with the availability requirements of [3.5] or [4.5]
- to keep the rudder steady in position in case of emergency.

In particular, for all ships with non-duplicated actuators, isolating valves are to be fitted at the connection of pipes to the actuator, and are to be directly fitted on the actuator.

2.2.4 Flexible hoses

- Flexible hoses may be installed between two points where flexibility is required but are not to be subjected to torsional deflexion (twisting) under normal operation. In general, the hose is to be limited to the length necessary to provide for flexibility and for proper operation of machinery.
- Hoses are to be high pressure hydraulic hoses according to recognised standards and suitable for the fluids, pressures, temperatures and ambient conditions in question.
- They are to be of a type approved by the Society according to Sec 10, [2.6].

2.2.5 Relief valves

- Relief valves shall be fitted to any part of the hydraulic system which can be isolated and in which pressure can be generated from the power source or from external forces. The setting of the relief valves shall not exceed the design pressure. The valves shall be of adequate size and so arranged as to avoid an undue rise in pressure above the design pressure.
- The setting pressure of the relief valves is not to be less than 1,25 times the maximum working pressure.
- The minimum discharge capacity of the relief valve(s) is not to be less than the total capacity of the pumps which can deliver through it (them), increased by 10%. Under such conditions, the rise in pressure is not to exceed 10% of the setting pressure. In this respect, due consideration is to be given to the foreseen extreme ambient conditions in relation to oil viscosity.

2.2.6 Hydraulic oil reservoirs

Hydraulic power-operated steering gear shall be provided with the following:

- a low level alarm for each hydraulic fluid reservoir to give the earliest practicable indication of hydraulic fluid leakage. Audible and visual alarms shall be given on the navigation bridge and in the machinery space where they can be readily observed.
- a fixed storage tank having sufficient capacity to recharge at least one power actuating system including the reservoir, where the main steering gear is required to be power operated. The storage tank shall be permanently connected by piping in such a manner that the hydraulic systems can be readily recharged from a position within the steering gear compartment and shall be provided with a contents gauge.

Note 1: For cargo ships of less than 500 tons gross tonnage, the storage means may consist of a readily accessible drum, of sufficient capacity to refill one power actuating system if necessary.

2.2.7 Hydraulic pumps

- Hydraulic pumps are to be type tested in accordance with the provisions of [8.1.1].
- Special care is to be given to the alignment of the pump and the driving motor.

2.2.8 Filters

- Hydraulic power-operated steering gear shall be provided with arrangements to maintain the cleanliness of

the hydraulic fluid taking into consideration the type and design of the hydraulic system.

- Filters of appropriate mesh fineness are to be provided in the piping system, in particular to ensure the protection of the pumps.

2.2.9 Accumulators

Accumulators, if fitted, are to be designed in accordance with Sec 10, [14.5.3].

2.2.10 Rudder actuators

- Rudder actuators, other than non-duplicated rudder actuators fitted to tankers and gas carriers of 10000 gross tonnage and above, are to be designed in accordance with the relevant requirements of Sec 3 for class I pressure vessels also considering the following provisions.
- The permissible primary general membrane stress is not to exceed the lower of the following values:

$$\frac{R}{A} \quad \text{or} \quad \frac{R_e}{B}$$
 where A and B are given in Tab 4.
- Oil seals between non-moving parts, forming part of the external pressure boundary, are to be of the metal upon metal or equivalent type.
- Oil seals between moving parts, forming part of the external pressure boundary, are to be duplicated, so that the failure of one seal does not render the actuator inoperative. Alternative arrangements providing equivalent protection against leakage may be accepted.
- The strength and connection of the cylinder heads (or, in the case of actuators of the rotary type, the fixed vanes) acting as rudder stops are to comply with the provisions of [7.3.1].

Table 4 : Value of coefficients A and B

Coefficient	Steel	Cast steel	Nodular cast iron
A	3,5	4	5
B	1,7	2	3

2.3 Electrical systems

2.3.1 General design

The electrical systems of the main steering gear and the auxiliary steering gear are to be so arranged that the failure of one will not render the other inoperative.

2.3.2 Power circuit supply

- Electric or electrohydraulic steering gear comprising one or more power units is to be served by at least two exclusive circuits fed directly from the main switchboard; however, one of the circuits may be supplied through the emergency switchboard.
- Auxiliary electric or electrohydraulic steering gear, associated with main electric or electrohydraulic steering gear, may be connected to one of the circuits supplying the main steering gear.

- c) The circuits supplying electric or electrohydraulic steering gear are to have adequate rating for supplying all motors which can be simultaneously connected to them and may be required to operate simultaneously.
- d) When, in a ship of less than 1600 tons gross tonnage, auxiliary steering gear which is required by [3.3.2], item c) to be operated by power is not electrically powered or is powered by an electric motor primarily intended for other services, the main steering gear may be fed by one circuit from the main switchboard.
- e) Where the rudder stock is required to be over 230 millimetres in diameter in way of the tiller, excluding strengthening for navigation in ice, an alternative power supply either from the emergency source of electrical power or from an independent source of power located in the steering gear compartment is to be provided, sufficient at least to supply the steering gear power unit such that the latter is able to perform the duties of auxiliary steering gear.

This power source is to be activated automatically, within 45 seconds, in the event of failure of the main source(s) of electrical power.

The independent source is to be used only for this purpose.

The alternative power source is also to supply the steering gear control system, the remote control of the power unit and the rudder angle indicator.
- f) In every ship of 10 000 tons gross tonnage and upwards, the alternative power supply is to have a capacity for at least 30 minutes of continuous operation and in any other ship for at least 10 minutes.

2.3.3 Motors and associated control gear

- a) To determine the required characteristics of the electric motors for power units, the breakaway torque and maximum working torque of the steering gear under all operating conditions are to be considered. The ratio of pull-out torque to rated torque is to be at least 1,6.
- b) Motors for steering gear power units may be rated for intermittent power demand.

The rating is to be determined on the basis of the steering gear characteristics of the ship in question; the rating is always to be at least:

 - S3 - 40% for motors of electric steering gear power units
 - S6 - 25% for motors of electrohydraulic steering gear power units and for converters.
- c) Each electric motor of a main or auxiliary steering gear power unit is to be provided with its own separate motor starter gear, located within the steering gear compartment.

2.3.4 Supply of motor control circuits and steering gear control systems

- a) Each control for starting and stopping of motors for power units is to be served by its own control circuits supplied from its respective power circuits.
- b) Any electrical main and auxiliary steering gear control system operable from the navigating bridge is to be

served by its own separate circuit supplied from a steering gear power circuit from a point within the steering gear compartment, or directly from switchboard busbars supplying that steering gear power circuit at a point on the switchboard adjacent to the supply to the steering gear power circuit. The power supply systems are to be protected selectively.

- c) The remote control of the power unit and the steering gear control systems is to be supplied also by the alternative power source when required by [2.3.2], item e).

2.3.5 Circuit protection

- a) Short-circuit protection is to be provided for each control circuit and each power circuit of electric or electrohydraulic main and auxiliary steering gear.
- b) No protection other than short-circuit protection is to be provided for steering gear control system supply circuits.
- c) Protection against excess current (e.g. by thermal relays), including starting current, if provided for power circuits, is to be for not less than twice the full load current of the motor or circuit so protected, and is to be arranged to permit the passage of the appropriate starting currents.
- d) Where fuses are fitted, their current ratings are to be two step higher than the rated current of the motors. However, in the case of intermittent service motors, the fuse rating is not to exceed 160% of the rated motor current.
- e) The instantaneous short-circuit trip of circuit breakers is to be set to a value not greater than 15 times the rated current of the drive motor.
- f) The protection of control circuits is to correspond to at least twice the maximum rated current of the circuit, though not, if possible, below 6 A.

2.3.6 Starting and stopping of motors for steering gear power units

- a) Motors for power units are to be capable of being started and stopped from a position on the navigation bridge and from a point within the steering gear compartment.
- b) Means are to be provided at the position of motor starters for isolating any remote control starting and stopping devices (e.g. by removal of the fuse-links or switching off the automatic circuit breakers).
- c) Main and auxiliary steering gear power units are to be arranged to restart automatically when power is restored after a power failure.

2.3.7 Separation

- a) Duplicated electric power circuits are to be separated as far as practicable.
- b) Cables for duplicated electric power circuits with their associated components are to be separated as far as practicable. They are to follow different routes separated

both vertically and horizontally, as far as practicable, throughout their entire length.

- c) Duplicated steering gear control systems with their associated components are to be separated as far as practicable.
- d) Cables for duplicated steering gear control systems with their associated components are to be separated as far as practicable. They are to follow different routes separated both vertically and horizontally, as far as practicable, throughout their entire length.
- e) Wires, terminals and the components for duplicated steering gear control systems installed in units, control boxes, switchboards or bridge consoles are to be separated as far as practicable.
Where physical separation is not practicable, separation may be achieved by means of a fire-retardant plate.
- f) All electrical components of the steering gear control systems are to be duplicated. This does not require duplication of the steering wheel or steering lever.
- g) If a joint steering mode selector switch (uniaxial switch) is employed for both steering gear control systems, the connections for the control systems are to be divided accordingly and separated from each other by an isolating plate or air gap.
- h) In the case of double follow-up control, the amplifier is to be designed and fed so as to be electrically and mechanically separated. In the case of non-follow-up control and follow-up control, it is to be ensured that the follow-up amplifier is protected selectively.
- i) Control circuits for additional control systems, e.g. steering lever or autopilot, are to be designed for all-pole disconnection.
- j) The feedback units and limit switches, if any, for the steering gear control systems are to be separated electrically and mechanically connected to the rudder stock or actuator separately.
- k) Actuators controlling the power systems of the steering gear, e.g. magnetic valves, are to be duplicated and separated.

2.4 Alarms and indications

2.4.1 Power units

- a) In the event of a power failure to any one of the steering gear power units, an audible and visual alarm shall be given on the navigating bridge.
- b) Means for indicating that the motors of electric and electrohydraulic steering gear are running shall be installed on the navigating bridge and at a suitable main machinery control position.
- c) Where a three-phase supply is used, an alarm shall be provided that will indicate failure of any one of the supply phases.
- d) An overload alarm shall be provided for each motor of electric or electrohydraulic steering gear power units.
- e) The alarms required in c) and d) shall be both audible and visual and situated in a conspicuous position in the

main machinery space or control room from which the main machinery is normally controlled.

2.4.2 Hydraulic system

- a) Hydraulic oil reservoirs are to be provided with the alarms required in [2.2.6].
- b) Where hydraulic locking, caused by a single failure, may lead to loss of steering, an audible and visual alarm, which identifies the failed system, is to be provided on the navigating bridge.

Note 1: This alarm is to be activated when, for example:

- the position of the variable displacement pump control system does not correspond with the given order, or
- an incorrect position in the 3-way valve, or similar, in the constant delivery pump system is detected.

2.4.3 Control system

In the event of a failure of electrical power supply to the steering gear control systems, an audible and visual alarm shall be given on the navigating bridge.

An indication (or an alarm) is to be given on the navigating bridge in the event that the steering gear remote control system is not available (e.g. the steering gear control is from the local control position).

2.4.4 Rudder angle indication

The angular position of the rudder is to be:

- a) indicated on the navigating bridge, if the main steering gear is power operated. The rudder angle indication is to be independent of the steering gear control system and be supplied through the emergency switchboard, or by an alternative and independent source of electrical power such as that referred to in [2.3.2], item e);
- b) recognisable in the steering gear compartment.

2.4.5 Summary table

Displays and alarms are to be provided in the locations indicated in Tab 5.

3 Design and construction - Requirements for cargo ships of 500 tons gross tonnage or more

3.1 Application

3.1.1 The provisions of this Article apply in addition to those of Article [2].

3.2 General

3.2.1 Unless expressly provided otherwise, every ship shall be provided with main steering gear and auxiliary steering gear to the satisfaction of the Society.

Table 5 : Location of displays and alarms

Item	Display	Alarms (audible and visible)	Location		
			Navigation Bridge	Engine Control Room	Steering gear compartment
Power failure of each power unit		X	X	X	
Indication that electric motor of each power unit is running	X		X	X	
Overload of electric motor of each power unit		X	X	X	
Phase failure of electric motor of each power unit		X	X	X	
Low level of each hydraulic fluid reservoir		X	X	X	
Power failure of each control system		X	X	X	
Hydraulic lock		X	X		
Rudder angle indicator	X		X		X

3.3 Strength, performance and power operation of the steering gear

3.3.1 Main steering gear

The main steering gear and rudder stock shall be:

- of adequate strength and capable of steering the ship at maximum ahead service speed which shall be demonstrated,
- capable of putting the rudder over from 35° on one side to 35° on the other side with the ship at its deepest seagoing draught and running ahead at maximum ahead service speed and, under the same conditions, from 35° on either side to 30° on the other side in not more than 28s,
- operated by power where necessary to meet the requirements of b) and in any case when the Society requires a rudder stock of over 120 mm diameter in way of the tiller, excluding strengthening for navigation in ice, and
- so designed that they will not be damaged at maximum astern speed; however, this design requirement need not be proved by trials at maximum astern speed and maximum rudder angle.

3.3.2 Auxiliary steering gear

The auxiliary steering gear and rudder stock shall be:

- of adequate strength and capable of steering the ship at navigable speed and of being brought speedily into action in an emergency,
- capable of putting the rudder over from 15° on one side to 15° on the other side in not more than 60s with the ship at its deepest seagoing draught and running ahead at one half of the maximum ahead service speed or 7 knots, whichever is the greater, and
- operated by power where necessary to meet the requirements of b) and in any case when the Society requires a

rudder stock of over 230 mm diameter in way of the tiller, excluding strengthening for navigation in ice.

3.4 Control of the steering gear

3.4.1 Main and auxiliary steering gear control

Steering gear control shall be provided:

- for the main steering gear, both on the navigation bridge and in the steering gear compartment,
- where the main steering gear is arranged in accordance with [3.5.2], by two independent control systems, both operable from the navigation bridge and the steering gear compartment. This does not require duplication of the steering wheel or steering lever. Where the control system consists in a hydraulic telemotor, a second independent system need not be fitted, except in a tanker, gas carrier of 10 000 gross tonnage and upwards,
- for the auxiliary steering gear, in the steering gear compartment and, if power operated, it shall also be operable from the navigation bridge and to be independent of the control system for the main steering gear.

3.4.2 Control systems operable from the navigating bridge

Any main and auxiliary steering gear control system operable from the navigating bridge shall comply with the following:

- if electrical, it shall be served by its own separate circuit supplied from a steering gear power circuit from a point within the steering gear compartment, or directly from switchboard busbars supplying that steering gear power circuit at a point on the switchboard adjacent to the supply to the steering gear power circuit,

- means shall be provided in the steering gear compartment for disconnecting any control system operable from the navigation bridge from the steering gear it serves,
- the system shall be capable of being brought into operation from a position on the navigating bridge,
- in the event of failure of electrical power supply to the control system, an audible and visual alarm shall be given on the navigation bridge, and
- short-circuit protection only shall be provided for steering gear control supply circuits.

3.5 Availability

3.5.1 Arrangement of main and auxiliary steering gear

The main steering gear and the auxiliary steering gear shall be so arranged that the failure of one will not render the other inoperative.

3.5.2 Omission of the auxiliary steering gear

Where the main steering gear comprises two or more identical power units, auxiliary steering gear need not be fitted, provided that:

- a) in a cargo ship, the main steering gear is capable of operating the rudder as required by paragraph [3.3.1] while operating with all power units,
- b) the main steering gear is so arranged that after a single failure in its piping system or in one of the power units, the defect can be isolated so that steering capability can be maintained or speedily regained.

Steering gear other than of the hydraulic type is to achieve standards equivalent to the requirements of this paragraph to the satisfaction of the Society.

3.5.3 Hydraulic power supply

The hydraulic system intended for main and auxiliary steering gear is to be independent of all other hydraulic systems of the ship.

3.5.4 Non-duplicated components

Special consideration is to be given to the suitability of any essential component which is not duplicated.

3.5.5 Hydraulic locking

Where the steering gear is so arranged that more than one system (either power or control) can be simultaneously operated, the risk of hydraulic locking caused by single failure is to be considered.

4 Design and construction - Requirements for cargo ships of less than 500 tons gross tonnage

4.1 Application

4.1.1 The provisions of this Article apply in addition to those of Article [2].

4.2 General

4.2.1 Unless expressly provided otherwise, every ship is to be provided with main steering gear and auxiliary steering gear to the satisfaction of the Society.

The Society may accept an arrangement whereby the two steering gears units share common mechanical components (tiller, quadrant, rudder actuators) provided that any defect can be isolated so that steering capability can be maintained or speedily regained.

4.3 Strength, performance and power operation of the steering gear

4.3.1 Main steering gear

The main steering gear and rudder stock are to be:

- a) of adequate strength and capable of steering the ship at maximum ahead service speed, which is to be demonstrated,
- b) capable of putting the rudder over from 35° on one side to 35° on the other side with the ship at its deepest seagoing draught and running ahead at maximum ahead service speed and, under the same conditions, from 35° on either side to 30° on the other side in not more than 28s,
- c) operated by power where necessary to fulfil the requirements of b), and
- d) so designed that they will not be damaged at maximum astern speed; however, this design requirement need not be proved by trials at maximum astern speed and maximum rudder angle.

4.3.2 Auxiliary steering gear

The auxiliary steering gear is to be:

- a) of adequate strength and sufficient to steer the ship at navigable speed and capable of being brought speedily into action in an emergency,
- b) capable of putting the rudder over from 15° on one side to 15° on the other side in not more than 60s with the ship at its deepest seagoing draught and running ahead at one half of the maximum ahead service speed or 7 knots, whichever is the greater, and
- c) operated by power where necessary to meet the requirements of b).

4.3.3 Hand operation

Hand operation of steering gear is permitted when it requires an effort less than 160 N.

4.4 Control of the steering gear

4.4.1 Control of the main steering gear

- a) Control of the main steering gear is to be provided on the navigation bridge.
- b) Where the main steering gear is arranged in accordance with [4.5.2], two independent control systems are to be provided, both operable from the navigation bridge. This does not require duplication of the steering wheel or steering lever.

4.4.2 Control of the auxiliary steering gear

- a) Control of the auxiliary steering gear is to be provided on the navigation bridge, in the steering gear compartment or in another suitable position.
- b) If the auxiliary steering gear is power operated, its control system is also to be independent of that of the main steering gear.

4.5 Availability

4.5.1 Arrangement of main and auxiliary means for actuating the rudder

The main steering gear and the auxiliary means for actuating the rudder are to be arranged so that a single failure in one will not render the other inoperative.

4.5.2 Omission of the auxiliary steering gear Where the main steering gear comprises two or more identical power units, auxiliary steering gear need not be fitted, provided that the main steering gear is capable of operating the rudder:

- a) as required in [4.3.1], item b), while operating with all power units
- b) as required in [4.3.2], item b), while any one of the power units is out of operation.

The main steering gear is to be so arranged that, after a single failure in its piping system or in one of the power units, the defect can be isolated so that steering capability can be maintained or speedily regained.

The Society may accept the fitting of steering gear of proven service reliability even where it does not comply with the requirements laid down here as far as the hydraulic system is concerned.

4.5.3 Hydraulic power supply

Hydraulic power installations supplying steering gear may also supply other equipment at the same time provided that the operation of the steering gear is not affected:

- a) by the operation of this equipment, or
- b) by any failure of this equipment or of its hydraulic supply piping.

5 Design and construction - Requirements for ships equipped with several rudders

5.1 Principle

5.1.1 General

In addition to the provisions of Articles [2], [3] and [4], as applicable, ships equipped with two or more aft rudders are to comply with the provisions of this Article.

5.1.2 Availability

Where the ship is fitted with two or more rudders, each having its own actuation system, the latter need not be duplicated.

5.1.3 Equivalent rudder stock diameter

Where the rudders are served by a common actuating system, the diameter of the rudder stock referred to in [3.3.1], item c) and in [3.3.2] item c) is to be replaced by the equivalent diameter d obtained from the following formula:

$$d = \sqrt[3]{\sum_j d_j^3}$$

with:

d_j : Rule diameter of the upper part of the rudder stock of each rudder in way of the tiller, excluding strengthening for navigation in ice.

5.2 Synchronisation

5.2.1 General

A system for synchronising the movement of the rudders is to be fitted, either:

- by a mechanical coupling, or
- by other systems giving automatic synchronising adjustment.

5.2.2 Non-mechanical synchronisation

Where the synchronisation of the rudder motion is not achieved by a mechanical coupling, the following provisions are to be met:

- a) the angular position of each rudder is to be indicated on the navigation bridge,
- b) the rudder angle indicators are to be independent from each other and, in particular, from the synchronising system,
- c) in case of failure of the synchronising system, means are to be provided for disconnecting this system so that steering capability can be maintained or rapidly regained. See also Pt E, Ch 1, Sec 4, [7.2.1].

6 Design and construction - Requirements for ships equipped with non-traditional propulsion and steering systems, such as thrusters

6.1 Principle

6.1.1 General

Ships equipped with non-traditional propulsion and steering systems, such as thrusters, are to comply with the provisions of this Section, as far as applicable, and with the content of this Article 6.

The main and auxiliary steering gear referred to in [3] and [4] above may consist of thrusters of the following types:

- azimuth thrusters
- water-jets
- cycloidal propellers

complying with the provisions of Sec 12, as far as applicable.

6.1.2 Actuation system

Thrusters used as steering means are to be fitted with a main actuation system and an auxiliary actuation system.

6.1.3 Control system

Where the steering means of the ship consists of two or more thrusters, their control system is to include a device ensuring an automatic synchronisation of the thruster rotation, unless each thruster is so designed as to withstand any additional forces resulting from the thrust exerted by the other thrusters.

6.2 Use of azimuth thrusters

6.2.1 Azimuth thrusters used as sole steering means

Where the ship is fitted with one azimuth thruster used as the sole steering means, this thruster is to comply with [3.3.1] or [4.3.1], as applicable, except that:

- a) the main actuation system is required to be capable of a rotational speed of at least 0,4 RPM and to be operated by power where the expected steering torque exceeds 1,5 kN·m
- b) the auxiliary actuation system is required to be capable of a rotational speed of at least 0,1 RPM and to be operated by power where the expected steering torque exceeds 3 kN·m.

6.2.2 Azimuth thrusters used as auxiliary steering gear

Where the auxiliary steering gear referred to in [3.2.1] or [4.2.1] consists of one or more azimuth thrusters, at least one such thruster is to be capable of:

- steering the ship at maximum ahead service speed
- being brought speedily into action in case of emergency
- an average rotational speed of at least 2,4°/s.

The auxiliary actuation system referred to in [6.1.2] need not be fitted.

6.2.3 Omission of the auxiliary actuation system

Where the steering means of the ship consists of two independent azimuth thrusters or more, the auxiliary actuation system referred to in [6.1.2] need not be fitted provided that:

- the thrusters are so designed that the ship can be steered with any one thruster out of operation and each of the steering systems is arranged so that after a single failure in its piping or in one of the power units, ship steering capability (but not individual steering system operation) can be maintained or speedily regained (e.g. by the possibility of positioning the thruster in a neutral steering position in an emergency, if needed), and;
- for cargo ships, each of the thrusters is fitted one or more identical power units, capable of satisfying the requirements in [6.2.1] a) while operating with all power units.

6.3 Use of water-jets

6.3.1

The use of water-jets as steering means is subject to the requirements given in [6.2] as far as applicable; other arrangements will be given special consideration by the Society.

7 Arrangement and installation

7.1 Steering gear room arrangement

7.1.1 The steering gear compartment shall be:

- a) readily accessible and, as far as practicable, separated from machinery spaces, and
- b) provided with suitable arrangements to ensure working access to steering gear machinery and controls. These arrangements shall include handrails and gratings or other non-slip surfaces to ensure suitable working conditions in the event of hydraulic fluid leakage.

7.2 Rudder actuator installation

7.2.1

- a) Rudder actuators are to be installed on foundations of strong construction so designed as to allow the transmission to the ship structure of the forces resulting from the torque applied by the rudder and/or by the actuator, considering the strength criteria defined in [2.1.3] and [7.3.1]. The structure of the ship in way of the foundations is to be suitably strengthened.
- b) Where the rudder actuators are bolted to the hull, the grade of the bolts used is not to be less than 8.8. Unless the bolts are adjusted and fitted with a controlled tightening, strong shocks are to be fitted in order to prevent any lateral displacement of the rudder actuator.

7.3 Overload protections

7.3.1 Mechanical rudder stops

- a) The steering gear is to be provided with strong rudder stops capable of mechanically stopping the rotation of

the rudder at an angle slightly greater than its maximum working angle. Alternatively, these stops may be fitted on the ship to act on another point of the mechanical transmission system between the rudder actuator and the rudder blade.

- b) The scantlings of the rudder stops and of the components transmitting to the ship's structure the forces applied on these stops are to be determined for the greater value of the torques T_R or T_G .

Where $T_G \geq 1,5T_R$, the rudder stops are to be fitted between the rudder actuator and the rudder stock, unless the rudder stock as well as all the components transmitting mechanical forces between the rudder actuator and the rudder blade are suitably strengthened.

7.3.2 Rudder angle limiters

- a) Power-operated steering gear is to be provided with positive arrangements, such as limit switches, for stopping the gear before the rudder stops are reached. These arrangements are to be synchronised with the gear itself and not with the steering gear control.
- b) Special consideration will be given to power-operated steering gear where the rudder may be oriented to more than 35° .

7.3.3 Relief valves

Relief valves are to be fitted in accordance with [2.2.5].

7.3.4 Buffers

Buffers are to be provided on all ships fitted with mechanical steering gear. They may be omitted on hydraulic gear equipped with relief valves or with calibrated bypasses.

7.4 Means of communication

7.4.1 A means of communication is to be provided between the navigation bridge and the steering gear compartment.

If electrical, it is to be fed through the emergency switchboard or to be sound powered.

7.5 Operating instructions

7.5.1 For steering gear comprising two identical power units intended for simultaneous operation, both normally provided with their own (partly or mutually) separate control systems, the following standard notice is either to be placed on a signboard fitted at a suitable place on the steering control post on the bridge or incorporated into the operation manual:

CAUTION

IN SOME CIRCUMSTANCES WHEN 2 POWER UNITS ARE RUNNING SIMULTANEOUSLY, THE RUDDER MAY NOT RESPOND TO THE HELM. IF THIS HAPPENS STOP EACH PUMP IN TURN UNTIL CONTROL IS REGAINED.

8 Certification, inspection and testing

8.1 Type tests of hydraulic pumps

8.1.1 Each type of power unit pump is to be subjected in the workshop to a type test of not less than 100 hours' duration.

The test arrangements are to be such that the pump may run both:

- in idling conditions, and
- at maximum delivery capacity at maximum working pressure.

During the test, idling periods are to be alternated with periods at maximum delivery capacity at maximum working pressure. The passage from one condition to another is to occur at least as quickly as on board.

During the test, no abnormal heating, excessive vibration or other irregularities are permitted.

After the test, the pump is to be disassembled and inspected.

Note 1: Type tests may be waived for a power unit which has been proven to be reliable in marine service.

8.2 Testing of materials

8.2.1 Components subject to pressure or transmitting mechanical forces

- a) Materials of components subject to pressure or transmitting mechanical forces, specifically:
- cylindrical shells of hydraulic cylinders, rams and piston rods
 - tillers, quadrants
 - rotors and rotor housings for rotary vane steering gear
 - hydraulic pump casings
 - and hydraulic accumulators, if any,

are to be duly tested, including examination for internal defects, in accordance with the requirements of Part D.

- b) A works' certificate may be accepted for low stressed parts, provided that all characteristics for which verification is required are guaranteed by such certificate.

8.2.2 Hydraulic piping, valves and accessories

Tests for materials of hydraulic piping, valves and accessories are to comply with the provisions of Sec 10, [20.3].

8.3 Inspection and tests during manufacturing

8.3.1 Components subject to pressure or transmitting mechanical forces

- a) The mechanical components referred to in [8.2.1] are to be subjected to appropriate non-destructive tests. For hydraulic cylinder shells, pump casings and accumulators, refer to Sec 3.
- b) Defects may be repaired by welding only on forged parts or steel castings of weldable quality. Such repairs are to be conducted under the supervision of the Surveyor in accordance with the applicable requirements of Part D.

8.3.2 Hydraulic piping, valves and accessories

Hydraulic piping, valves and accessories are to be inspected and tested during manufacturing in accordance with Sec 10, [20], for a class I piping system.

8.4 Inspection and tests after completion

8.4.1 Hydrostatic tests

- a) Hydraulic cylinder shells and accumulators are to be subjected to hydrostatic tests according to the relevant provisions of Sec 3.
- b) Hydraulic piping, valves and accessories and hydraulic pumps are to be subjected to hydrostatic tests according to the relevant provisions of Sec 10, [20.4].

8.4.2 Shipboard tests

After installation on board the ship, the steering gear is to be subjected to the tests detailed in Sec 15, [3.11].

8.4.3 Sea trials

For the requirements of sea trials, refer to Sec 15.

SECTION 10 THRUSTERS

1 General

1.1 Application

1.1.1 The requirements of this Section apply to the following types of thrusters:

- Transverse thrusters intended for manoeuvring developing power equal to 500 kW or more
- Thrusters intended for propulsion, steering and dynamic positioning developing power equal to 220 kW or more; for power less than 220 kW the requirements apply only to the propeller and relevant shaft.

For azimuth thrusters intended for dynamic positioning, the additional requirements in Pt F, Ch 10, Sec 4 are to be complied with.

For ships with an ice class notation, the additional requirements in Part F, Chapter 6 are to be complied with, except for transverse thrusters not intended for dynamic positioning.

1.1.2 Thrusters developing power less than that indicated in [1.1.1] are to be built in accordance with sound marine practice and tested as required in [3.2] to the satisfaction of the Surveyor.

1.2 Definitions

1.2.1 Transverse thruster

A transverse thruster is an athwartship thruster developing a thrust in a transverse direction for manoeuvring purposes.

1.2.2 Azimuth thruster

An azimuth thruster is a thruster which has the capability to develop thrust in any direction through 360°.

1.2.3 Water-jet

A water-jet is equipment constituted by a tubular casing (or duct) enclosing an impeller. The shape of the casing is such as to enable the impeller to produce a water-jet of such intensity as to give a positive thrust. Water-jets may have means for deviating the jet of water in order to provide a steering function.

1.2.4 Continuous duty thruster

A continuous duty thruster is a thruster which is designed for continuous operation, such as a propulsion thruster.

1.2.5 Intermittent duty thruster

An intermittent duty thruster is a thruster designed for operation at full power for a period not exceeding 1 hour, followed by operation at reduced rating for a limited period of time not exceeding a certain percentage of the hours in a day and a certain (lesser) percentage of the hours in a year. In general, athwartship thrusters are intermittent duty thrusters.

1.3 Thrusters intended for propulsion

1.3.1 In general, at least two azimuth thrusters are to be fitted in ships where these are the sole means of propulsion. Single azimuth thruster installations will be specially considered by the Society on a case by case basis.

Single water-jet installations are permitted.

1.4 Documentation to be submitted

1.4.1 Plans to be submitted for athwartship thrusters and azimuth thrusters

For thrusters:

- intended for propulsion, steering and dynamic positioning
- intended for manoeuvring developing power equal to 500 kW or more,

the plans listed in Tab 1 are to be submitted. Plans as per item 6 of Tab 1 are also to be submitted for thrusters developing power less than 500 kW.

1.4.2 Plans to be submitted for water-jets

The plans listed in Tab 2 are to be submitted.

1.4.3 Additional data to be submitted

The data and documents listed in Tab 3 are to be submitted by the manufacturer together with the plans.

2 Design and Construction

2.1 Materials

2.1.1 Propellers

For requirements relative to material intended for propellers, see Sec 6.

2.1.2 Other thruster components

For the requirements relative to materials intended for other parts of the thrusters, such as gears, shaft, couplings, etc., refer to the applicable parts of the Rules.

Table 1 : Plans to be submitted for athwartship thrusters and azimuth thrusters

No.	A/I (1)	ITEM
General requirements for all thrusters		
1	I	General arrangement of the thruster
2	A	Propeller, including the applicable details mentioned in Sec 8
3	A	Bearing details
4	A	Propeller and intermediate shafts
5	A	Gears, including the calculations according to Sec 6 for cylindrical gears or standards recognised by the Society for bevel gears
Specific requirements for transverse thrusters		
6	A	Structure of the tunnel showing the materials and their thickness
7	A	Structural equipment or other connecting devices which transmit the thrust from the propeller to the tunnel
8	A	Sealing devices (propeller shaft gland and thruster-tunnel connection)
9	A	For the adjustable pitch propellers: pitch control device and corresponding monitoring system
Specific requirements for rotating and azimuth thrusters		
10	A	Structural items (nozzle, bracing, etc.)
11	A	Structural connection to hull
12	A	Rotating mechanism of the thruster
13	A	Thruster control system
14	A	Piping systems connected to thruster
(1) A = to be submitted for approval in four copies I = to be submitted for information in duplicate		

Table 2 : Plans to be submitted for water-jets

No.	A/I (1)	ITEM
1	I	General arrangement of the water-jet
2	A	Casing (duct) (location and shape) showing the materials and the thicknesses as well as the forces acting on the hull
3	A	Details of the shafts, flanges, keys
4	I	Sealing gland
5	A	Bearings
6	A	Impeller
7	A	Steering and reversing buckets and their control devices as well as the corresponding hydraulic diagrams
(1) A = to be submitted for approval in four copies I = to be submitted for information in duplicate		

Table 3 : Data and documents to be submitted for athwartship thrusters, azimuth thrusters and water-jets

No.	A/I (1)	ITEM
1	I	Rated power and revolutions
2	I	Rated thrust
3	A	Material specifications of the major parts, including their physical, chemical and mechanical properties
4	A	Where parts of thrusters are of welded construction, all particulars on the design of welded joints, welding procedures, heat treatments and non-destructive examinations after welding
5	I	Where applicable, background information on previous operating experience in similar applications
(1) A = to be submitted for approval in four copies I = to be submitted for information in duplicate		

2.2 Transverse thrusters and azimuth thrusters

2.2.1 Prime movers

- a) Diesel engines intended for driving thrusters are to comply with the applicable requirements of Sec 2.
- b) Electric motors intended for driving thrusters and their feeding systems are to comply with the requirements of Chapter 2. In particular:
 - Provisions are to be made to prevent starting of the motors whenever there are insufficient generators in operation.
 - Intermittent duty thrusters will be the subject of special consideration by the Society.

2.2.2 Propellers

- a) For propellers of thrusters intended for propulsion, steering and dynamic positioning, the requirements of Sec 6 apply.
- b) For propellers of thrusters intended for manoeuvring only, the requirements of Sec 6 also apply, although the increase in thickness of 10% required in Sec 6, [2.5] does not need to be applied.

2.2.3 Shafts

- a) For propeller shafts of thrusters, the requirements of Sec 5 apply to the portion of propellershaft between the inner edge of the aftermost shaft bearing and the inner face of the propeller boss or the face of the integral propeller shaft flange for the connection to the propeller boss.
- b) For other shafts of thrusters, the requirement of Sec 4, [3.4.2] apply.

2.2.4 Gears

- a) Gears of thrusters intended for propulsion steering and dynamic positioning are to be in accordance with the

applicable requirements of Sec 4 for cylindrical gears or standards recognised by the Society for bevel gears, applying the safety factors for propulsion gears.

- b) Gears of thrusters intended for manoeuvring only are to be in accordance with the applicable requirements of Sec 4, for cylindrical gears or Standards recognised by the Society for bevel gears, applying the safety factors for auxiliary gears.

2.2.5 Nozzles and connections to hull for azimuth thrusters

- a) For the requirements relative to the nozzle structure, see Part B, Chapter 10.
- b) The scantlings of the nozzle connection to the hull and the welding type and size will be specially considered by the Society, which reserves the right to require detailed stress analysis in the case of certain high power installations.
- c) For steerable thrusters, the equivalent rudder stock diameter is to be calculated in accordance with the requirements of Part B, Chapter 10.

2.2.6 Transverse thruster tunnel

- a) The thickness of the tunnel is not to be less than the adjacent part of the hull.
- b) Special consideration will be given by the Society to tunnels connected to the hull by connecting devices other than welding.

2.2.7 Bearings

Bearing are to be identifiable and are to have a life adequate for the intended purpose. However, their life cannot be less than:

- 40 000 hours for continuous duty thrusters. For ships with restricted service, a lesser value may be considered by the Society.
- 5 000 hours for intermittent duty thrusters.

Table 4 : Azimuth thrusters

Symbol convention H = High, HH = High high, G = group alarm L = Low, LL = Low low, I = individual alarm X = function is required, R = remote	Monitoring		Automatic control				
			Thruster			Auxiliary	
Identification of system parameter	Alarm	Indication	Slow-down	Shut-down	Control	Stand by Start	Stop
Steering oil pressure	L						
Oil tank level	L						

2.3 Water-jets

2.3.1 Shafts

The diameter of the shaft supporting the impeller, measured at bottom of keyway or at spline inner diameter, is not to be less than the diameter d_2 , in mm, obtained by the following formula:

$$d_2 = 100fh \cdot \left(\frac{P}{N}\right)^{1/3}$$

where:

- P : Power, in kW
 N : Rotational speed, in rpm
 f : Calculated as follows:

$$f = \left(\frac{560}{R_m + 160}\right)^{1/3}$$

where R_m is the ultimate tensile strength of the shaft material, in N/mm²

- h : 1 when the shaft is only transmitting torque loads, and when the weight and thrust of the propeller are totally supported by devices located in the fixed part of the thruster
 1,22 otherwise.

The shafts are to be protected against corrosion by means of either a continuous liner or an oil-gland of an approved type, or by the nature of the material of the shaft.

2.3.2 Casings and impellers

Casings and impellers are subject of special consideration by the Society.

2.3.3 Steering performance

Steering performance and emergency steering availability are to be at least equivalent to the requirements in Sec 9, [6.2] and Sec 9, [6.3].

2.4 Alarm, monitoring and control systems

2.4.1 General

In addition to those of this item, the general requirements given in Chapter 3 apply.

In the case of ships with automation notations, the requirements in Part F, Chapter 2 also apply.

2.4.2 Steering thruster controls

- Controls for steering are to be provided from the navigating bridge, the machinery control station and locally.
- Means are to be provided to stop any running thruster at each of the control stations.
- A thruster angle indicator is to be provided at each steering control station. The angle indicator is to be independent of the control system.

2.4.3 Alarm and monitoring equipment

Tab 4 summarises the minimum alarm and monitoring requirements for propulsion and steering thrusters. See also Sec 9, [6].

3 Testing and certification

3.1 Material tests

3.1.1 Propulsion and steering thrusters

All materials intended for parts transmitting torque and for propeller/impeller blades are to be tested in accordance with the applicable requirements of Sec 4, [5.2] or Sec 5, [4.1], or Sec 8, [4.1] in the presence of a Surveyor.

3.1.2 Transverse thrusters

Material testing for parts of athwartship thrusters does not need to be witnessed by a Surveyor, provided full test reports are made available to him.

3.2 Testing and inspection

3.2.1 Thrusters

Thrusters are to be inspected as per the applicable requirements given in the Rules for the specific components.

3.2.2 Prime movers

Prime movers are to be tested in accordance with the requirements applicable to the type of mover used.

3.3 Certification

3.3.1 Certification of thrusters

Thrusters are to be individually tested and certified by the Society.

3.3.2 Mass produced thrusters

Mass produced thrusters may be accepted within the framework of the type approval program of the Society.

SECTION 11

REFRIGERATING INSTALLATIONS

1 General

1.1 Application

1.1.1 Refrigerating installations on all ships

The minimum safety requirements addressed in this Section are to be complied with for any refrigerating plant installed on board a ship to be classed by the Society. These requirements do not cover any operation or availability aspect of the plants, which are not the subject of class requirements, unless an additional notation is requested.

2 Minimum design requirements

2.1 Refrigerating installation components

2.1.1 General

In general, the specific requirements stated in Part C of the Rules for various machinery and equipment are also applicable to refrigerating installation components.

2.1.2 Pressure vessels and heat exchangers

- Pressure vessels of refrigerating plants are to comply with the relevant requirements of Sec 3.
- Vessels intended to contain ammonia or toxic substances are to be considered as class 1 pressure vessels as indicated in Sec 3, [1.4].
- The materials used for pressure vessels are to be appropriate to the fluid that they contain. Where ammonia is the refrigerant, copper, bronze, brass and other copper alloys are not to be used.
- Notch toughness of steels used in low temperature plants is to be suitable for the thickness and the lowest design temperature. A check of the notch toughness properties may be required where the working temperature is below minus 40°C.

2.1.3 Piping systems

- Refrigerant pipes are generally to be regarded as pressure pipes.
- Refrigerant, brine and sea water pipes are to satisfy the requirements of Sec 8, as applicable.
- Refrigerant pipes are to be considered as belonging to the following classes:
 - class I: where they are intended for ammonia or toxic substances
 - class II: for other refrigerants
 - class III: for brine.
- In general, the pipes conveying the cooling medium are not to come into direct contact with the ship's structure; they are to be carefully insulated on their run outside

the refrigerated spaces, and more particularly when passing through bulkheads and decks.

- The materials used for the pipes are to be appropriate to the fluids that they convey. Copper, brass, bronze and other copper alloys are not to be used for pipes likely to convey ammonia. Methods proposed for joining such pipes are to be submitted to the Society for consideration.
- Notch toughness of the steels used is to be suitable for the application concerned.
- Where necessary, cooling medium pipes within refrigerated spaces or embedded in insulation are to be externally protected against corrosion; for steel pipes, this protection is to be ensured by galvanisation or equivalent. All useful precautions are to be taken to protect the joints of such pipes against corrosion.
- The use of plastic pipes will be considered by the Society on a case by case basis.

2.2 Refrigerants

2.2.1 Prohibited refrigerants

The use of the following refrigerants is not allowed for shipboard installations:

- Methyl chloride
- R11 - Trichloromonofluoromethane (C Cl₃ F)
- Ethane
- Ethylene
- Other substances with lower explosion limit in air of more than 3,5%.

2.2.2 Statutory requirements

Particular attention is to be paid to any limitation on the use of refrigerants imposed by the Administration of the State whose flag the ship is flying.

2.2.3 Toxic or flammable refrigerants

The arrangement of refrigerating machinery spaces of plants using toxic or flammable refrigerants will be the subject of special consideration by the Society.

For specific requirements on spaces intended for plants using ammonia as a refrigerant, see [2.3].

2.3 Special requirements for ammonia (R717)

2.3.1 Refrigerating machinery compartment

- The refrigerating machinery compartment and the compartments where ammonia bottles are stored are to be separated by gastight bulkheads from the accommodation spaces, the engine room (including the shaft tunnel) and other machinery spaces intended for essential ser-

vices. This requirement does not apply to plants using less than 25 kg of ammonia.

- b) The space is to be arranged with a ventilation system, distinct from that of other spaces, having a capacity of at least 30 changes per hour. Provision is to be made for starting and stopping the ventilation fans from outside the refrigerated space.
- c) A fire-extinguishing water spray system is to be provided for any ammonia machinery space, in particular in way of the access doors. The actuating device is to be fitted closed to the entrance outside the protected space.
- d) At least two access doors are to be provided. One of these doors is to be used for emergency and is to lead directly to an open space. The doors are to open outwards and are to be self-closing.
- e) Where the access to a refrigerating machinery space is through an accommodation or machinery space, the ventilation of the former is to be such as to keep it under negative pressure with respect to the adjacent space, or, alternatively, the access is to be provided with an air lock.
- f) An independent bilge system is to be provided for the refrigerating machinery space.
- g) At least two sets of breathing apparatus and protective clothing are to be available outside and in the vicinity of the ammonia machinery space.
- h) All electrical equipment and apparatus in the space is to be arranged such that it may be shut off by a central

switch located outside the space. This switch is not to control the ventilation system.

- i) The electrical equipment and apparatus in the space is to comply with the requirements for electrical installations in dangerous areas as per Ch 2, Sec 3, [10].

2.3.2 Ammonia in machinery spaces

When installation of ammonia is allowed in the machinery space in accordance with the provision of [2.3.1] a), the area where ammonia machinery is installed is to be served by a hood with a negative ventilation system, having a capacity of not less than 30 changes per hour, independent from any other ship ventilation system, so as to prevent any leakage of ammonia from dissipating into other areas.

2.3.3 Unattended machinery spaces

Where the refrigerating machinery spaces are not permanently attended, a gas detection system with an audible and visual alarm is to be arranged in a suitable location. This system is also to stop the compressor when a flammable gas concentration is reached.

2.3.4 Segregation

Ammonia piping is not to pass through accommodation spaces.

SECTION 12

TURBOCHARGERS

1 General

1.1 Application

1.1.1 These Rules apply to turbochargers fitted on the diesel engines listed in Sec 2, [1.1.1] a) and b) having a power of 1000 kW and above.

1.1.2 Turbochargers not included in [1.1.1] are to be designed and constructed according to sound marine practice and delivered with the works' certificate (W) relevant to the bench running test as per [4.4.3] and the hydrostatic test as per [4.4.4].

1.1.3 In the case of special types of turbochargers, the Society reserves the right to modify the requirements of this Section, demand additional requirements in individual cases and require that additional plans and data be submitted.

1.2 Documentation to be submitted

1.2.1 The Manufacturer is to submit to the Society the documents listed in Tab 1.

2 Design and construction

2.1 Monitoring

2.1.1 General

In addition to those of this item, the general requirements given in Chapter 2 apply.

2.1.2 Indicators

The local indicators for turbochargers fitted on diesel engines having a power of 2000 kW and above to be installed on ships without automation notations are given in Sec 2, Tab 2.

3 Arrangement and installation

3.1 General

3.1.1 The arrangement and installation are to be such as to avoid any unacceptable load on the turbocharger.

4 Type tests, material tests, workshop inspection and testing, certification

4.1 Type tests

4.1.1 Turbochargers as per [1.1.1] admitted to an alternative inspection scheme are to be type approved.

Table 1 : Documentation to be submitted

No.	I/A (1)	Document
1	A	Longitudinal cross-sectional assembly with main dimensions
2	A	Rotating parts (shaft, wheels and blades)
3	A	Details of blade fixing
4	A	Technical specification of the turbocharger including the maximum operating conditions (maximum permissible rotational speed and maximum permissible temperature)
5	A	Material specifications for the main parts, including their physical, chemical and mechanical properties, values of tensile strength, average stress to produce creep, resistance to corrosion and heat treatments
6	I	Operation and service manual
<p>(1) A = to be submitted for approval, in four copies; I = to be submitted for information, in duplicate.</p> <p>Note 1: Plans mentioned under items (2) and (3) are to be constructional plans with all main dimensions and are to contain any necessary information relevant to the type and quality of the materials employed. In the case of welded rotating parts, all relevant welding details are to be included in the above plans and the procedures adopted for welding or for any heat treatments will be subject to approval by the Society</p>		

The type test is to be carried out on a standard unit taken from the assembly line and is to be witnessed by the Surveyor. Normally, the type test is to consist of a hot gas running test of one hour's duration at the maximum permissible speed and maximum permissible temperature. After the test the turbocharger is to be opened up and examined.

For Manufacturers who have facilities for testing the turbocharger unit on an engine for which the turbocharger is to be type approved, replacement of the hot running test by a test run of one hour's duration at overload (110% of the rated output) may be considered.

4.2 Identification of parts

4.2.1 Rotating parts of the turboblower are to be marked for easy identification with the appropriate certificate.

4.3 Material tests

4.3.1 Material tests (mechanical properties and chemical composition) are required for shafts and rotors, including blades (see [4.5.2] as regards the certificate required).

4.4 Workshop inspections and testing

4.4.1 Overspeed test

All wheels (impellers and inducers), when machine-finished and complete with all fittings and blades, are to undergo an overspeed test for at least 3 minutes at one of the following test speeds:

- a) 20% above the maximum speed at room temperature
- b) 10% above the maximum speed at the maximum working temperature.

Note 1: If each forged wheel is individually controlled by an approved non-destructive examination method no overspeed test may be required except for wheels of the type test unit.

4.4.2 Balancing

Each shaft and bladed wheel, as well as the complete rotating assembly, is to be dynamically balanced by means of equipment which is sufficiently sensitive in relation to the size of the rotating part to be balanced.

4.4.3 Bench running test

Each turbocharger is to undergo a mechanical running test at the bench for 20 minutes at maximum rotational speed at room temperature.

Subject to the agreement of the Society, the duration of the running test may be reduced to 10 minutes, provided that

the Manufacturer is able to verify the distribution of defects found during the running tests on the basis of a sufficient number of tested turbochargers.

For Manufacturers who have facilities in their works for testing turbochargers on an engine for which they are intended, the bench test may be replaced by a test run of 20 minutes at overload (110% of the maximum continuous output) on such engine.

Where turbochargers are admitted to an alternative inspection scheme and subject to the satisfactory findings of a historical audit, the Society may accept a bench test carried out on a sample basis.

4.4.4 Hydrostatic tests

The cooling spaces of turbochargers are to be hydrostatically tested at a test pressure of 0,4 MPa or 1,5 times the maximum working pressure, whichever is the greater.

4.5 Certification

4.5.1 Type Approval Certificate and its validity

Subject to the satisfactory outcome of the type tests specified in [4.1], the Society will issue to the turbocharger Manufacturer a Type Approval Certificate valid for all turbochargers of the same type.

4.5.2 Testing certification

a) Turbochargers admitted to an alternative inspection scheme

A statement, issued by the Manufacturer, is required certifying that the turbocharger conforms to the one type tested. The reference number and date of the Type Approval Certificate are also to be indicated in the statement (see Pt D, Ch 1, Sec 1, [4.2.2]).

Works' certificates (W) (see Pt D, Ch 1, Sec 1, [4.2.3]) are required for material tests as per [4.3] and for works trials as per [4.4].

b) Turbochargers not admitted to an alternative inspection scheme

Society's certificates (C) (see Pt D, Ch 1, Sec 1, [4.2.1]) are required for the bench running test as per [4.4.3] and the overspeed test as per [4.4.1], as well as for material and hydrostatic tests as per [4.3] and [4.4.4].

Works' certificates (W) (see Pt D, Ch 1, Sec 1, [4.2.3]) may be accepted for material tests, in place of the Society's certificates, for turbochargers fitted on diesel engines having a cylinder diameter of 300 mm or less.

SECTION 13

TESTS ON BOARD

1 General

1.1 Application

1.1.1 This Section covers shipboard tests, both at the moorings and during sea trials. Such tests are additional to the workshop tests required in the other Sections of this Chapter.

1.2 Purpose of shipboard tests

1.2.1 Shipboard tests are intended to demonstrate that the main and auxiliary machinery and associated systems are functioning properly, in particular in respect of the criteria imposed by the Rules. The tests are to be witnessed by a Surveyor.

1.3 Documentation to be submitted

1.3.1 A comprehensive list of the shipboard tests intended to be carried out by the shipyard is to be submitted to the Society.

For each test, the following information is to be provided:

- scope of the test
- parameters to be recorded.

2 General requirements for shipboard tests

2.1 Trials at the moorings

2.1.1 Trials at the moorings are to demonstrate the following:

- a) satisfactory operation of the machinery in relation to the service for which it is intended
- b) quick and easy response to operational commands
- c) safety of the various installations, as regards:
 - the protection of mechanical parts
 - the safeguards for personnel
- d) accessibility for cleaning, inspection and maintenance.

Where the above features are not deemed satisfactory and require repairs or alterations, the Society reserves the right to require the repetition of the trials at the moorings, either wholly or in part, after such repairs or alterations have been carried out.

2.2 Sea trials

2.2.1 Scope of the tests

Sea trials are to be conducted after the trials at the moorings and are to include the following:

- a) demonstration of the proper operation of the main and auxiliary machinery, including monitoring, alarm and safety systems, under realistic service conditions
- b) check of the propulsion capability when one of the essential auxiliaries becomes inoperative
- c) detection of dangerous vibrations by taking the necessary readings when required
- d) checks either deemed necessary for ship classification or requested by the interested parties and which are possible only in the course of navigation in open sea.

2.2.2 Exemptions

Exemption from some of the sea trials may be considered by the Society in the case of ships having a sister ship for which the satisfactory behaviour in service is demonstrated.

Such exemption is, in any event, to be agreed upon by the interested parties and is subject to the satisfactory results of trials at the moorings to verify the safe and efficient operation of the propulsion system.

3 Shipboard tests for machinery

3.1 Conditions of sea trials

3.1.1 Displacement of the ship

Except in cases of practical impossibility, or in other cases to be considered individually, the sea trials are to be carried out at a displacement as close as possible to the deadweight (full load) or to one half of the deadweight (half load).

3.1.2 Power of the machinery

- a) The power developed by the propulsion machinery in the course of the sea trials is to be as close as possible to the power for which classification has been requested. In general, this power is not to exceed the maximum continuous power at which the weakest component of the propulsion system can be operated. In cases of diesel engines, it is not to exceed the maximum continuous power for which the engine type concerned has been approved.
- b) Where the rotational speed of the shafting is different from the design value, thereby increasing the stresses in excess of the maximum allowable limits, the power developed in the trials is to be suitably modified so as to confine the stresses within the design limits.

3.1.3 Determination of the power and rotational speed

- a) The rotational speed of the shafting is to be recorded in the course of the sea trials, preferably by means of a continuous counter.
- b) In general, the power is to be determined by means of torsionometric readings, to be effected with procedures and instruments deemed suitable by the Society.

As an alternative, for reciprocating internal combustion engines, the power may be determined by measuring the fuel consumption and on the basis of the other operating characteristics, in comparison with the results of bench tests of the prototype engine.

Other methods of determining the power may be considered by the Society on a case by case basis.

3.2 Navigation and manoeuvring tests

3.2.1 Speed trials

- a) Where required by the Rules (see Pt A, Ch 1, Sec 2, [4.7.4]), the speed of the ship is to be determined using procedures deemed suitable by the Society.
- b) The ship speed is to be determined as the average of the speeds taken in not less than two pairs of runs in opposite directions.

3.2.2 Astern trials

- a) The ability of the machinery to reverse the direction of thrust of the propeller in sufficient time, and so to bring the ship to rest within reasonable distance from maximum ahead service speed, shall be demonstrated and recorded.
- b) The stopping times, ship headings and distances recorded on trials, together with the results of trials to determine the ability of ships having multiple propellers to navigate and manoeuvre with one or more propellers inoperative, shall be available on board for the use of the Master or designated personnel.
- c) Where the ship is provided with supplementary means for manoeuvring or stopping, the effectiveness of such means shall be demonstrated and recorded as referred to in paragraphs a) and b).

For electric propulsion systems, see [3.7].

3.3 Tests of boilers

3.3.1 General

The satisfactory operation of the main and auxiliary boilers supplying essential services is to be ascertained in all operating conditions during the trials at the moorings and the sea trials.

3.3.2 Tests to be performed

After installation on board, the following tests are to be carried out in the presence of the Surveyor:

- a) Test in the hot condition of boilers and superheaters
- b) Accumulation tests and setting of safety valves of boilers and superheaters
 - Safety valves are to be set to lift at a pressure not exceeding 103% of the design pressure
 - For boilers fitted with superheaters, the safety valves of the latter are to be set to lift before or, at the latest, at the same time as the valves of the saturated steam chest
- c) Verification that, at the maximum steaming rate, the boiler pressure does not exceed 110% of the design pressure when the stop valves of the boiler, except those which must remain open for the burning operation, are closed. The boiler is to be fed so that the water level remains normal throughout the test. The test is to last:
 - 15 minutes for fire tube boilers
 - 7 minutes for water tube boilers.
- d) Test and simulation of all safety devices, alarms, shut-off and automatic starting of standby equipment.

3.3.3 Alternative requirement

- a) When it is recognised, for certain types of boilers, that accumulation tests might endanger the superheaters, the omission of such tests may be considered.
- b) Such omission can be permitted, however, only if the drawings and the size of safety valves have been reviewed by the Society, and provided that the safety valves are of a type whose relieving capacity has been established by a test carried out in the presence of the Surveyor, or in other conditions deemed equivalent to those of the actual boiler.
- c) When the Society does not agree to proceed with an accumulation test, the valve manufacturer is to supply, for each safety valve, a certificate specifying its relieving capacity for the working conditions of the boiler. In addition, the boiler manufacturer is to supply a certificate specifying the maximum steam capacity of the boiler.

3.4 Tests of diesel engines

3.4.1 General

- a) The scope of the trials of diesel engines may be expanded in consideration of the special operating conditions, such as towing, etc.
- b) Where the machinery installation is designed for residual or other special fuels, the ability of engines to burn such fuels is to be demonstrated.

3.4.2 Main propulsion engines driving fixed propellers

Trials of main propulsion engines driving fixed propellers are to include the following tests:

- operation at rated engine speed n_0 for at least 4 hours
- operation at engine speed corresponding to normal continuous cruise power for at least 2 hours
- operation at engine speed $n = 1,032 n_0$ for 30 minutes

Note 1: The test in c) is to be performed only where permitted by the engine adjustment, see Note 1 to Sec 2, [4.5.3].

- operation at minimum load speed
- starting and reversing manoeuvres
- operation in reverse direction of propeller rotation at a minimum engine speed of $n = 0,7 n_0$ for 10 minutes

Note 2: The test in f) may be performed during the dock or sea trials

- tests of the monitoring, alarm and safety systems
- for engines fitted with independently driven blowers, emergency operation of the engine with one blower inoperative.

3.4.3 Main propulsion engines driving controllable pitch propellers or reversing gears

- The scope of the trials for main propulsion engines driving controllable pitch propellers or reversing gears is to comply with the relevant provisions of [3.4.2].
- Engines driving controllable pitch propellers are to be tested at various propeller pitches.

3.4.4 Single main engines driving generators for propulsion

Trials of engines driving generators for propulsion are to include the following tests:

- operation at 100% power (rated propulsion power) for at least 4 hours
- operation at normal continuous cruise propulsion power for at least 2 hours
- operation at 110% rated propulsion power for 30 minutes
- operation in reverse direction of propeller rotation at a minimum engine speed 70% of the nominal propeller speed for 10 minutes
- starting manoeuvres
- tests of the monitoring, alarm and safety systems.

Note 1: The above tests a) to f) are to be performed at rated speed with a constant governor setting. The powers refer to the rated electrical powers of the electric propulsion motors.

3.4.5 Engines driving auxiliaries

- Engines driving generators or important auxiliaries are to be subjected to an operational test for at least 4 hours. During the test, the set concerned is required to operate at its rated power for at least 2 hours.
- It is to be demonstrated that the engine is capable of supplying 100% of its rated power and, in the case of shipboard generating sets, account is to be taken of the times needed to actuate the generator's overload protection system.

3.5 Tests of electric propulsion system

3.5.1 Dock trials

- The dock trials are to include the test of the electrical production system, the power management and the load limitation.
- A test of the propulsion plant at a reduced power, in accordance with dock trial facilities, is to be carried out. During this test, the following are to be checked:
 - Electric motor rotation speed variation
 - Functional test, as far as practicable (power limitation is to be tested with a reduced value)
 - Protection devices
 - Monitoring and alarm transmission including interlocking system.
- Prior to the sea trials, an insulation test of the electric propulsion plant is to be carried out.

3.5.2 Sea trials

Testing of the performance of the electric propulsion system is to be effected in accordance with an approved test program.

This test program is to include at least:

- Speed rate of rise
- Endurance test:
 - 4 hours at 100% rated output power
 - 2 hours at the maximum continuous output power normally used at sea
 - 10 minutes at maximum astern running power
- Check of the crash astern operation in accordance with the sequence provided to reverse the speed from full ahead to full astern, in case of emergency. During this test, all necessary data concerning any effects of the reversing of power on the generators are to be recorded, including the power and speed variation
- Test of functionality of electric propulsion, when manoeuvring and during the ship turning test
- Test of power management performance: reduction of power due to loss of one or several generators to check, in each case, the power limitation and propulsion availability.

3.6 Tests of gears

3.6.1 Tests during sea trials

During the sea trials, the performance of reverse and/or reduction gearing is to be verified, both when running ahead and astern.

In addition, the following checks are to be carried out:

- check of the bearing and oil temperature
- detection of possible gear hammering, where required by Sec 7, [3.6.1]
- test of the monitoring, alarm and safety systems.

3.6.2 Check of the tooth contact

- Prior to the sea trials, the tooth surfaces of the pinions and wheels are to be coated with a thin layer of suitable coloured compound.

Upon completion of the trials, the tooth contact is to be inspected. The contact marking is to appear uniformly distributed without hard bearing at the ends of the teeth and without preferential contact lines.

The tooth contact is to comply with Tab 1.

- b) The verification of tooth contact at sea trials by methods other than that described above will be given special consideration by the Society.
- c) In the case of reverse and/or reduction gearing with several gear trains mounted on roller bearings, manufactured with a high standard of accuracy and having an input torque not exceeding 20 000 N·m, the check of the tooth contact may be reduced at the Society's discretion.

Such a reduction may also be granted for gearing which has undergone long workshop testing at full load and for which the tooth contact has been checked positively.

In any case, the teeth of the gears are to be examined by the Surveyor after the sea trials. Subject to the results, additional inspections or re-examinations after a specified period of service may be required.

Table 1: Tooth contact for gears

Heat treatment and machining	Percentage of tooth contact	
	across the whole face width	of the tooth working depth
quenched and tempered, cut	70	40
<ul style="list-style-type: none"> • quenched and tempered, shaved or ground • surface-hardened 	90	40

3.7 Tests of main propulsion shafting and propellers

3.7.1 Shafting alignment

Where alignment calculations are required to be submitted in pursuance of Sec 7, [3.3.1], the alignment conditions are to be checked on board as follows:

- a) shafting installation and intermediate bearing position, before and during assembling of the shafts:
 - optical check of the relative position of bushes after fitting
 - check of the flanged coupling parameters (gap and sag)
 - check of the centring of the shaft sealing glands
- b) engine (or gearbox) installation, with floating ship:
 - check of the engine (or gearbox) flanged coupling parameters (gap and sag)
 - check of the crankshaft deflections before and after the connection of the engine with the shaft line, by measuring the variation in the distance between adjacent webs in the course of one complete revolution of the engine

Note 1: The ship is to be in the loading conditions defined in the alignment calculations.

- c) load on the bearings:
 - check of the intermediate bearing load by means of jack-up load measurements
 - check of the bearing contact area by means of coating with an appropriate compound.

3.7.2 Shafting vibrations

Torsional, bending and axial vibration measurements are to be carried out where required by Sec 7.

The type of the measuring equipment and the location of the measurement points are to be specified.

3.7.3 Bearings

The temperature of the bearings is to be checked under the machinery power conditions specified in [3.1.2]

3.7.4 Stern tube sealing gland

The stern tube oil system is to be checked for possible oil leakage through the stern tube sealing gland.

3.7.5 Propellers

- a) For controllable pitch propellers, the functioning of the system controlling the pitch from full ahead to full astern position is to be demonstrated. It is also to be checked that this system does not induce any overload of the engine.
- b) The proper functioning of the devices for emergency operations is to be tested during the sea trials.

3.8 Tests of piping systems

3.8.1 Functional tests

During the sea trials, piping systems serving propulsion and auxiliary machinery, including the associated monitoring and control devices, are to be subjected to functional tests at the nominal power of the machinery. Operating parameters (pressure, temperature, consumption) are to comply with the values recommended by the equipment manufacturer.

3.8.2 Performance tests

The Society reserves the right to require performance tests, such as flow rate measurements, should doubts arise from the functional tests.

3.9 Tests of steering gear

3.9.1 General

- a) The steering gear is to be tested during the sea trials under the conditions stated in [3.1] in order to demonstrate, to the Surveyor's satisfaction, that the applicable requirements of Sec 9 are fulfilled.
- b) For controllable pitch propellers, the propeller pitch is to be set at the maximum design pitch approved for the maximum continuous ahead rotational speed.
- c) If the ship cannot be tested at the deepest draught, alternative trial conditions will be given special consideration by the Society. In such case, the ship speed corresponding to the maximum continuous number of revolutions of the propulsion machinery may apply.

3.9.2 Tests to be performed

Tests of the steering gear are to include at least:

- a) functional test of the main and auxiliary steering gear with demonstration of the performances required by Sec 9, [3.3] and Sec 9, [4.3].
- b) test of the steering gear power units, including transfer between steering gear power units
- c) test of the isolation of one power actuating system, checking the time for regaining steering capability
- d) test of the hydraulic fluid refilling system
- e) test of the alternative power supply required by Sec 9, [2.3.2], item e)
- f) test of the steering gear controls, including transfer of controls and local control
- g) test of the means of communication between the navigation bridge, the engine room and the steering gear compartment
- h) test of the alarms and indicators
- i) where the steering gear design is required to take into account the risk of hydraulic locking, a test is to be performed to demonstrate the efficiency of the devices intended to detect this.

Note 1: Tests d) to i) may be carried out either during the mooring trials or during the sea trials.

Note 2: For ships of less than 500 tons gross tonnage, the Society may accept departures from the above list, in particular to take into account the actual design features of their steering gear.

Note 3: Azimuth thrusters are to be subjected to the above tests, as far as applicable.

4 Inspection of machinery after sea trials

4.1 General

4.1.1

- a) For all types of propulsion machinery, those parts which have not operated satisfactorily in the course of the sea trials, or which have caused doubts to be expressed as to their proper operation, are to be disassembled or opened for inspection.

Machinery or parts which are opened up or disassembled for other reasons are to be similarly inspected.

- b) Should the inspection reveal defects or damage of some importance, the Society may require other similar machinery or parts to be opened up for inspection.
- c) An exhaustive inspection report is to be submitted to the Society for information.

4.2 Diesel engines

4.2.1

- a) In general, for all diesel engines, the following items are to be verified:
 - the deflection of the crankshafts, by measuring the variation in the distance between adjacent webs in the course of one complete revolution of the engine
 - the cleanliness of the lubricating oil filters.
- b) In the case of propulsion engines for which power tests have not been carried out in the workshop, some parts, agreed upon by the interested parties, are to be disas-

APPENDIX 1

CHECK FOR SCANTLINGS OF CRANKSHAFTS FOR DIESEL ENGINES

1 General

1.1 Application

1.1.1

- a) The requirements for the check of scantlings of crankshaft given in this Appendix apply to diesel engines as per Sec 2, [1.1.1] a) and b) capable of continuous operation of their maximum continuous power P as defined in Sec 2, [1.3.2], at the nominal maximum speed n. Where a crankshaft design involves the use of surface treated fillets, or when fatigue parameter influences are tested, or when working stresses are measured, the relevant documents with calculations/analysis are to be submitted to the Society in order to demonstrate equivalence to these requirements.
- b) The requirements of this Appendix apply only to solid forged and semi-built crankshafts of forged or cast steel, with one crankthrow between main bearings.

1.2 Documentation to be submitted

1.2.1 Required data for the check of the scantlings are indicated in the specific Society form as per item 1) of Sec 2, Tab 1.

1.3 Principles of calculation

1.3.1 The design of crankshafts is based on an evaluation of safety against fatigue in the highly stressed areas.

The calculation is also based on the assumption that the areas exposed to highest stresses are:

- fillet transitions between the crankpin and web as well as between the journal and web,
- outlets of crankpin oil bores.

When journal diameter is equal to or larger than crankpin diameter, the outlets of main journal oil bores are to be formed in a similar way to the crankpin oil bores; otherwise, separate documentation of fatigue safety may be required.

Calculation of crankshaft strength consists initially in determining the nominal alternating bending (see [2.1]) and nominal alternating torsional stresses (see [2.2]) which, multiplied by the appropriate stress concentration factors (see [3]), result in an equivalent alternating stress (uni-axial stress) (see [5]). This equivalent alternating stress is then compared with the fatigue strength of the selected crankshaft material (see [6]). This comparison will show whether or not the crankshaft concerned is dimensioned adequately (see [7]).

Figure 1 : Crankthrow of solid crankshaft

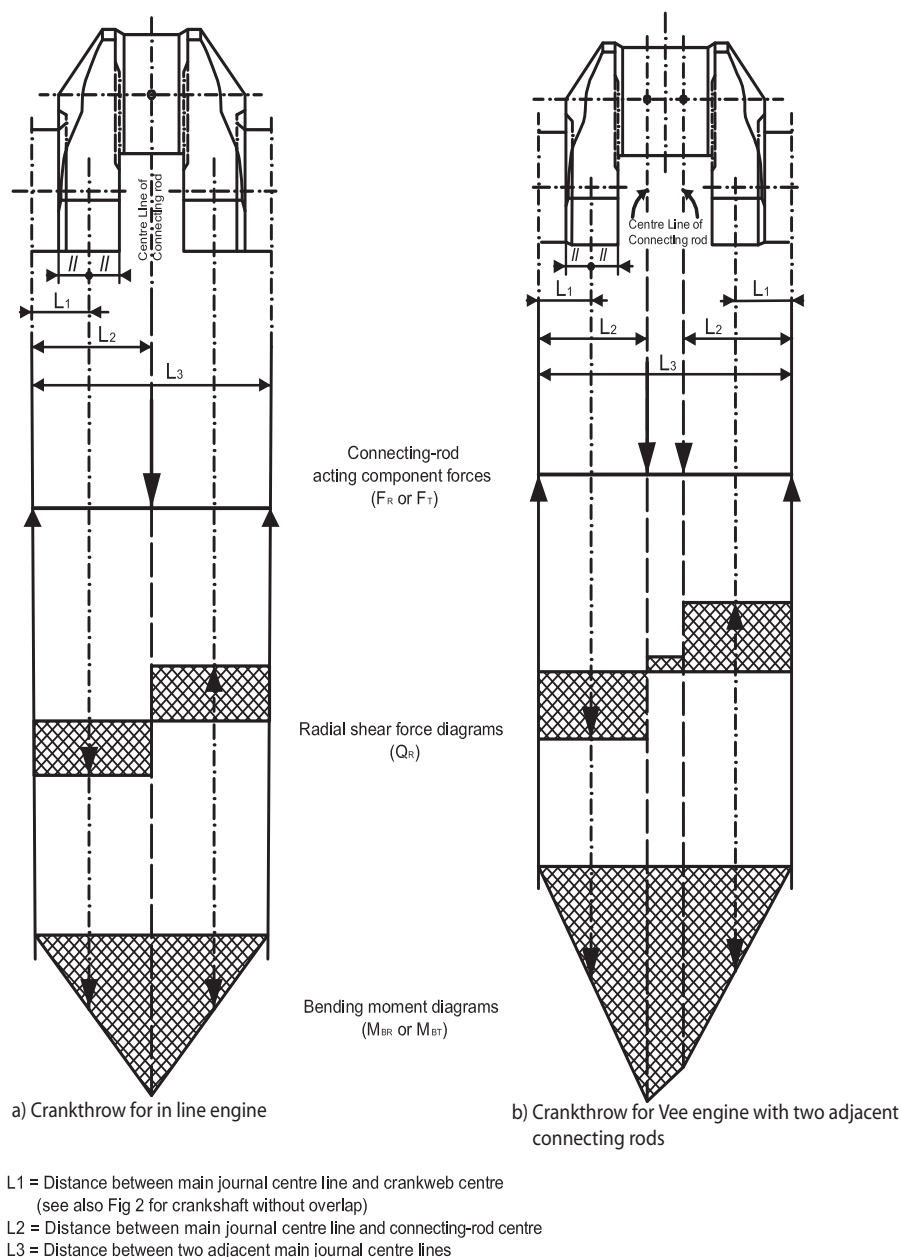

2 Calculation of stresses

2.1 Calculation of alternating stresses due to bending moments and radial forces

2.1.1 Assumptions

The calculation is based on a statically determined system, composed of a single crankthrow supported in the centre of adjacent main journals and subject to gas and inertia forces. The bending length is taken as the length between the two main bearing mid-points (distance L_3 , see Fig 1).

The bending moments M_{BR} , M_{BT} are calculated in the relevant section based on triangular bending moment diagrams due to the radial component F_R and tangential component F_T of the connecting rod force, respectively (see Fig 1a).

For crankthrows with two connecting rods acting upon one crankpin, the relevant bending moments are obtained by superposition of the two triangular bending moment diagrams according to phase (see Fig 1b)).

a) Bending moments and radial forces acting in web

The bending moment M_{BRF} and the radial force Q_{RF} are taken as acting in the centre of the solid web (distance L_1) and are derived from the radial component of the connecting rod force.

The alternating bending and compressive stresses due to bending moments and radial forces are to be related to the cross-section of the crank web. This reference section results from the web thickness W and the web width B (see Fig 2).

Mean stresses are disregarded.

Figure 2 : Reference area of crankweb cross-section

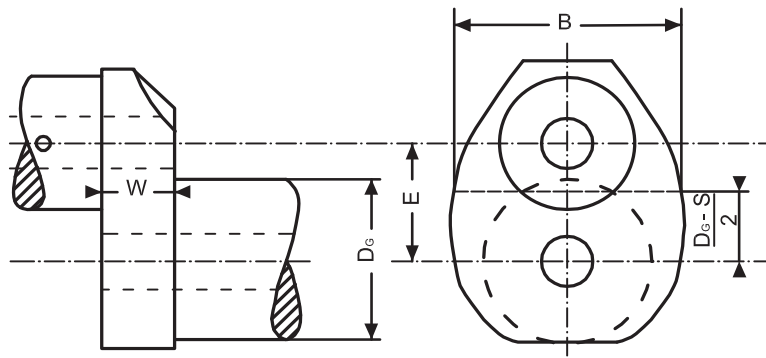

Overlapped crankshaft

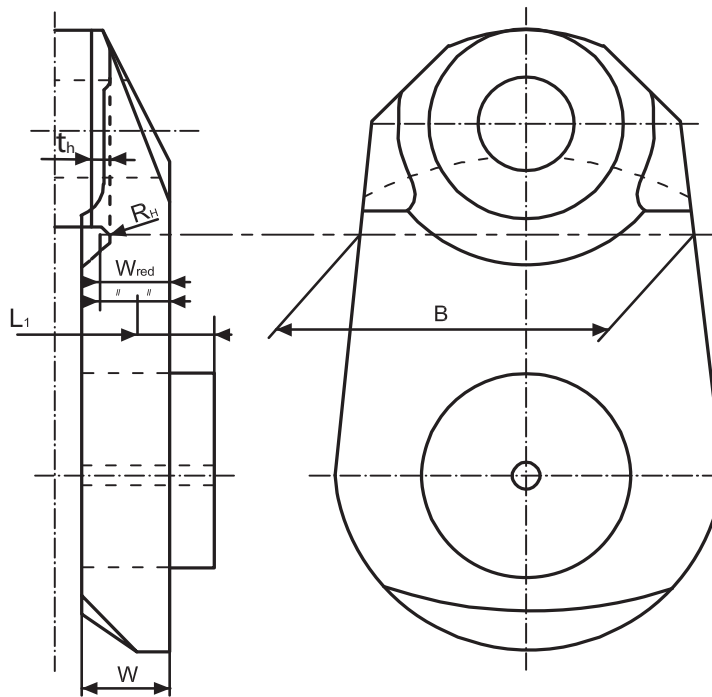

Crankshaft without overlap

- b) Bending acting in outlet of crankpin oil bore
 The two relevant bending moments are taken in the crankpin cross-section through the oil bore (see Fig 3).

The alternating stresses due to these bending moments are to be related to the cross-sectional area of the axially bored crankpin.
 Mean bending stresses are disregarded.

Figure 3 : Crankpin section through the oil bore

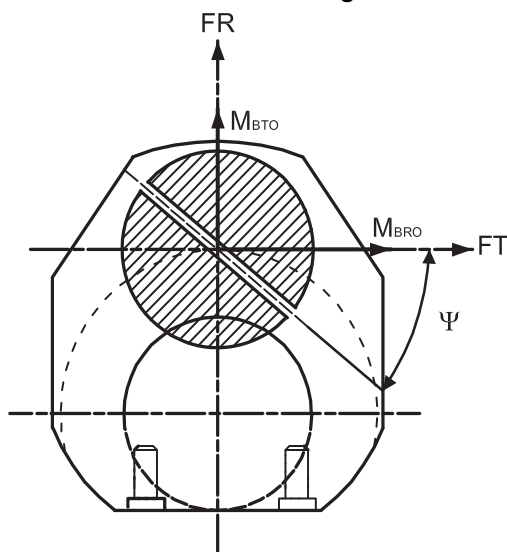

M_{BRO} is the bending moment of the radial component of the connecting-rod force

M_{BTO} is the bending moment of the tangential component of the connecting-rod force

2.1.2 Calculation of nominal alternating bending and compressive stresses in web

- a) The radial and tangential forces due to gas and inertia loads acting upon the crankpin at each connecting rod position will be calculated over one working cycle.

Using the forces calculated over one working cycle and taking into account the distance from the main bearing mid-point, the time curve of the bending moments M_{BRF} , M_{BRO} , M_{BTO} and radial forces Q_{RF} as defined in [2.1.1]b) and [2.1.1]c) will then be calculated.

In the case of V-type engines, the bending moments - progressively calculated from the gas and inertia forces - of the two cylinders acting on one crankthrow are superposed according to phase. Different designs (forked connecting rod, articulated type connecting rod or adjacent connecting rods) are to be taken into account.

Where there are cranks of different geometrical configurations in one crankshaft, the calculation is to cover all crank variants.

The decisive alternating values will then be calculated according to:

$$X_N = \pm \frac{1}{2} [X_{\max} - X_{\min}]$$

where:

X_N : is considered as alternating force, moment or stress

X_{\max} : is maximum value within one working cycle

X_{\min} : is minimum value within one working cycle

- b) The calculation of the nominal alternating bending and compressive stresses in the web cross-section is as follows:

$$\sigma_{BFN} = \pm \frac{M_{BRFN}}{W_{eqw}} \cdot 10^3 \cdot K_e$$

$$\sigma_{QFN} = \pm \frac{Q_{RFN}}{F} \cdot K_e$$

where:

σ_{BFN} [N/mm²]: nominal alternating bending stress related to the web.

M_{BRFN} [Nm]: alternating bending moment related to the centre of the web (see Fig 1).

$$M_{BRFN} = \pm \frac{1}{2} [M_{BRF\max} - M_{BRF\min}]$$

W_{eqw} [mm³]: section modulus related to the cross-section of the web.

$$W_{eqw} = \frac{B \cdot W^2}{6}$$

K_e : empirical factor considering to some extent the influence of adjacent crank and bearing restraint with:

$K_e = 0,8$ for 2-stroke engines

$K_e = 1,0$ for 4-stroke engines

σ_{QFN} [N/mm²]: nominal alternating compressive stress due to radial force related to the web

Q_{RFN} [N] : alternating radial force related to the web (see Fig 1)

$$Q_{RFN} = \pm \frac{1}{2} [Q_{RF\max} - Q_{RF\min}]$$

F [mm²] : area related to the cross-section of the web
 $F = B \cdot W$

- c) The calculation of nominal alternating bending stress in the outlet of the crankpin oil bore is as follows :

$$\sigma_{BON} = \pm \frac{M_{BON}}{W_e} \cdot 10^3$$

where:

σ_{BON} [N/mm²]: nominal alternating bending stress related to the crankpin diameter

M_{BON} [Nm]: alternating bending moment calculated at the outlet of the crankpin oil bore

$$M_{BON} = \pm \frac{1}{2} [M_{BO_{max}} - M_{BO_{min}}]$$

with:

$$M_{BO} = M_{BTO} \cdot \cos \psi + M_{BRO} \cdot \sin \psi$$

ψ [°]: angular position (see Fig 3)

W_e [mm³]: section modulus related to the cross-section of the axially bored crankpin

$$W_e = \frac{\pi}{32} \left[\frac{D^4 - D_{BH}^4}{D} \right]$$

2.1.3 Calculation of alternating bending stresses in fillets

The calculation of stresses is to be carried out for the crankpin fillet as well as for the journal fillet.

For the crankpin fillet:

$$\sigma_{BH} = \pm (\alpha_B \cdot \sigma_{BFN})$$

where:

σ_{BH} [N/mm²]: alternating bending stress in the crankpin fillet

α_B [-]: stress concentration factor for bending in the crankpin fillet (determination - see [3])

For the journal fillet (not applicable to semi-built crankshafts):

$$\sigma_{BG} = \pm (\beta_B \cdot \sigma_{BFN} + \beta_Q \cdot \sigma_{QFN})$$

where:

σ_{BG} [N/mm²]: alternating bending stress in the journal fillet

β_B [-]: stress concentration factor for bending in the journal fillet (determination - see [3])

β_Q [-]: stress concentration factor for compression due to radial force in the journal fillet (determination - see [3]).

2.1.4 Calculation of alternating bending stresses in the outlet of the crankpin oil bore

$$\sigma_{BO} = \pm (\gamma_B \cdot \sigma_{BON})$$

where:

σ_{BO} [N/mm²]: alternating bending stress in the outlet of the crankpin oil bore

γ_B [-]: stress concentration factor for bending in the crankpin oil bore (determination - see [3]).

2.2 Calculation of alternating torsional stresses

2.2.1 General

The calculation for nominal alternating torsional stresses is to be undertaken by the engine Manufacturer according to the information contained in [2.2.2].

The Manufacturer is to specify the maximum nominal alternating torsional stress.

2.2.2 Calculation of nominal alternating torsional stresses

The maximum and minimum torques are to be ascertained for every mass point of the complete dynamic system and for the entire speed range by means of a harmonic synthesis of the forced vibrations from the 1st order up to and including the 15th order for 2-stroke cycle engines and from the 0,5th order up to and including the 12th order for 4-stroke cycle engines. Whilst doing so, allowance is to be made for the damping that exists in the system and for unfavourable conditions (misfiring in one of the cylinders). The speed step calculation is to be selected in such a way that any resonance found in the operational speed range of the engine will be detected.

Note 1: Misfiring is defined as a cylinder condition when no combustion occurs but only a compression cycle.

Where barred speed ranges are necessary, they are to be arranged so that satisfactory operation is possible despite their existence. There are to be no barred speed ranges above a speed ratio of $\gamma \geq 0,8$ for normal firing conditions.

The values received from such calculation are to be submitted to the Society.

The nominal alternating torsional stress in every mass point, which is essential to the assessment, results from the following equation:

$$\tau_N = \pm \frac{M_{TN}}{W_p} \cdot 10^3$$

$$M_{TN} = \pm \frac{1}{2} \cdot (M_{Tmax} - M_{Tmin})$$

$$W_p = \frac{\pi}{16} \cdot \left(\frac{D^4 - D_{BH}^4}{D} \right) \text{ or } W_p = \frac{\pi}{16} \cdot \left(\frac{D^4 - D_{BG}^4}{D} \right)$$

where:

τ_N [N/mm²]: nominal alternating torsional stress referred to the crankpin or journal

M_{TN} [Nm]: maximum alternating torque

W_p [mm³]: polar section modulus related to the cross-section of the axially bored crankpin or bored journal

M_{Tmax} [Nm]: maximum value of the torque

M_{Tmin} [Nm]: minimum value of the torque.

For the purpose of the crankshaft assessment, the nominal alternating torsional stress considered in further calculations is the highest calculated value, according to above method, occurring at the most torsionally loaded mass point of the crankshaft system.

Where barred speed ranges exist, the torsional stresses within these ranges are not to be considered for assessment calculations.

The approval of the crankshaft will be based on the installation having the largest nominal alternating torsional stress (but not exceeding the maximum figure specified by the engine Manufacturer).

Thus, for each installation, it is to be ensured by suitable calculation that this approved nominal alternating torsional

stress is not exceeded. This calculation is to be submitted for assessment.

2.2.3 Calculation of alternating torsional stresses in fillets and the outlet of the crankpin oil bore

The calculation of stresses is to be carried out for the crankpin fillet, the journal fillet and the outlet of the crankpin oil bore. For the crankpin fillet:

$$\tau_H = \pm (\alpha_T \cdot \tau_N)$$

where:

τ_H [N/mm²]: alternating torsional stress in the crankpin fillet

α_T [-] : stress concentration factor for torsion in the crankpin fillet (determination - see [3])

τ_N [N/mm²]: nominal alternating torsional stress related to the crankpin diameter.

For the journal fillet (not applicable to semi-built crankshafts):

$$\tau_G = \pm (\beta_T \cdot \tau_N)$$

where:

τ_G [N/mm²]: alternating torsional stress in the journal fillet

β_T [-] : stress concentration factor for torsion in the journal fillet (determination - see [3])

τ_N [N/mm²]: nominal alternating torsional stress related to the journal diameter.

For the outlet of the crankpin oil bore:

$$\alpha_{TO} = \pm (\gamma_T \cdot \tau_N)$$

where:

α_{TO} [N/mm²]: alternating stress in the outlet of the crankpin oil bore due to torsion

γ_T [-] : stress concentration factor for torsion in the outlet of the crankpin oil bore (determination- see [3])

τ_N [N/mm²]: nominal alternating torsional stress related to crankpin diameter.

3 Evaluation of stress concentration factors

3.1 General

3.1.1

The stress concentration factors are evaluated by means of the formulae according to items [3.2], [3.3] and [3.4] applicable to the fillets and crankpin oil bore of solid forged web type crankshafts and to the crankpin fillets of semi-built crankshafts only. It is to be noted that stress concentration factor formulae concerning the oil bore are only applicable to a radially drilled oil hole. All formulae are based on investigations of FVV (Forschungsvereinigung Verbrennungskraftmaschinen) for fillets and on investigations of ESDU (Engineering Science Data Unit) for oil holes.

Where the geometry of the crankshaft is outside the boundaries of the analytical stress concentration factors (SCF), the calculation method detailed in [9] may be undertaken.

All crank dimensions necessary for the calculation of stress concentration factors are shown in Fig 4 and Tab 1.

The stress concentration factor for bending (α_B , β_B) is defined as the ratio of the maximum equivalent stress (VON MISES) - occurring in the fillets under bending load - to the nominal bending stress related to the web cross-section (see Tab 4).

The stress concentration factor for compression (β_Q) in the journal fillet is defined as the ratio of the maximum equivalent stress (VON MISES) - occurring in the fillet due to the radial force - to the nominal compressive stress related to the web cross-section.

The stress concentration factor for torsion (α_T , β_T) is defined as the ratio of the maximum equivalent shear stress - occurring in the fillets under torsional load - to the nominal torsional stress related to the axially bored crankpin or journal cross-section (see Tab 4).

The stress concentration factors for bending (γ_B) and torsion (γ_T) are defined as the ratio of the maximum principal stress - occurring at the outlet of the crankpin oil hole under bending and torsional loads - to the corresponding nominal stress related to the axially bored crankpin cross-section (see Tab 5).

When reliable measurements and/or calculations are available, which can allow direct assessment of stress concentration factors, the relevant documents and their method of analysis are to be submitted to the Society in order to demonstrate their equivalence to the present Rule evaluation.

Figure 4 : Crank dimensions

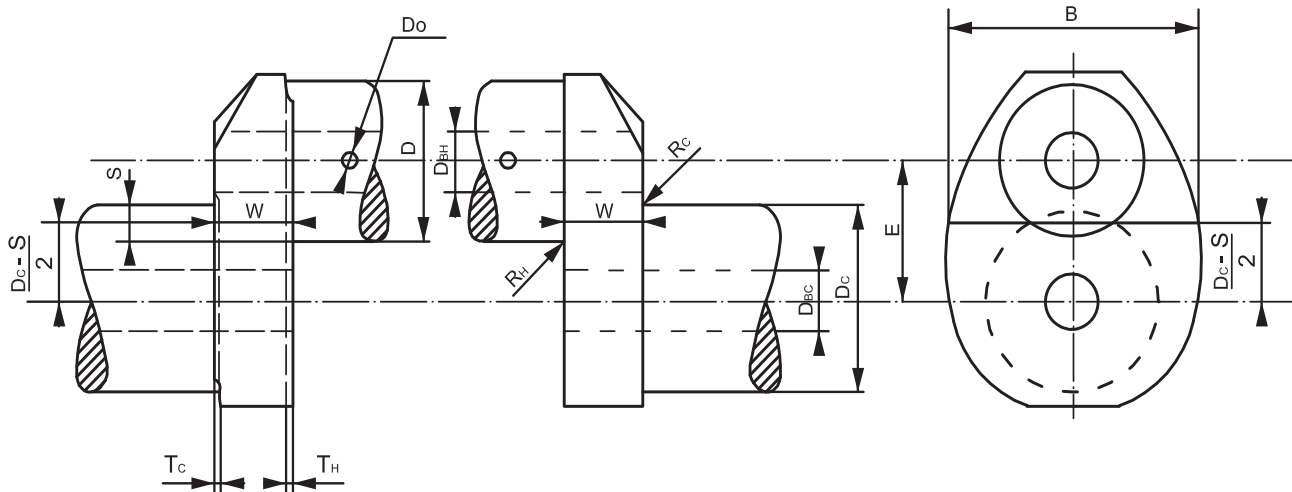

Table 1 : Actual dimensions

D	[mm]	crankpin diameter
D _{BH}	[mm]	diameter of axial bore in crankpin
D _O	[mm]	diameter of oil bore in crankpin
R _H	[mm]	fillet radius of crankpin
T _H	[mm]	recess of crankpin fillet
D _G	[mm]	journal diameter
D _{BG}	[mm]	diameter of axial bore in journal
R _G	[mm]	fillet radius of journal
T _G	[mm]	recess of journal fillet
E	[mm]	pin eccentricity
S	[mm]	pin overlap
		$S = \frac{D + D_G}{2} - E$
W (*)	[mm]	web thickness
B (*)	[mm]	web width
(*) In the case of 2-stroke semi-built crankshafts: <ul style="list-style-type: none"> when $T_H > R_H$, the web thickness is to be considered as equal to : $W_{red} = W - (T_H - R_H)$ [refer to Fig 2] web width B is to be taken in way of the crankpin fillet radius centre according to Fig 2 		

The related dimensions in Tab 2 will be applied for the calculation of stress concentration factors in the crankpin fillet and in the journal fillet.

Table 2 : Related dimensions

Crankpin fillet	Journal fillet
$r = R_H / D$	$r = R_G / D$
s	$= S/D$
w	$= W/D$ crankshafts with overlap W_{red}/D crankshafts without overlap
b	$= B/D$
d _o	$= D_O/D$
d _G	$= D_{BG}/D$
d _H	$= D_{BH}/D$
t _H	$= T_H/D$
t _G	$= T_G/D$

Stress concentration factors are valid for the ranges of related dimensions for which the investigations have been carried out. Ranges are as follows:

$$S \leq 5$$

$$0,2 \leq w \leq 0,8$$

$$1,1 \leq b \leq 2,2$$

$$0,03 \leq r \leq 0,13$$

$$0 \leq d_G \leq 0,8$$

$$0 \leq d_H \leq 0,8$$

$$0 \leq d_o \leq 0,2$$

Low range of s can be extended down to large negative values provided that:

- If calculated f (recess) < 1 then the factor f (recess) is not to be considered (f (recess) = 1)
- If $s < - 0,5$ then f (s,w) and f (r,s) are to be evaluated replacing the actual value of s by - 0,5.

3.2 Crankpin fillet

3.2.1 The stress concentration factor for bending (α_B) is :

$$\alpha_B = 2,6914 \cdot f(s,w) \cdot f(w) \cdot f(b) \cdot f(r) \cdot f(d_G) \cdot f(d_H) \cdot f(\text{recess})$$

where:

$$f(s,w) = -4,1883 + 29,2004 \cdot w - 77,5925 \cdot w^2 + 91,9454 \cdot w^3 - 40,0416 \cdot w^4 + (1-s) \cdot (9,5440 - 58,3480 \cdot w + 159,3415 \cdot w^2 - 192,5846 \cdot w^3 + 85,2916 \cdot w^4) + (1-s)^2 \cdot (-3,8399 + 25,0444 \cdot w - 70,5571 \cdot w^2 + 87,0328 \cdot w^3 - 39,1832 \cdot w^4)$$

$$f(w) = 2,1790 \cdot w^{0,7171}$$

$$f(b) = 0,6840 - 0,0077 \cdot b + 0,1473 \cdot b^2$$

$$f(r) = 0,2881 \cdot r^{(-0,5231)}$$

$$f(d_G) = 0,9993 + 0,27 \cdot d_G - 1,0211 \cdot d_G^2 + 0,5306 \cdot d_G^3$$

$$f(d_H) = 0,9978 + 0,3145 \cdot d_H - 1,5241 \cdot d_H^2 + 2,4147 \cdot d_H^3$$

$$f(\text{recess}) = 1 + (t_H + t_G) \cdot (1,8 + 3,2 \cdot s)$$

The stress concentration factor for torsion (α_T) is :

$$\alpha_T = 0,8 \cdot f(r,s) \cdot f(b) \cdot f(w)$$

where:

$$f(r,s) = r^{(-0,322+0,1015 \cdot (1-s))}$$

$$f(b) = 7,8955 - 10,654 \cdot b + 5,3482 \cdot b^2 - 0,857 \cdot b^3$$

$$f(w) = w^{(-0,145)}$$

3.3 Journal fillet (not applicable to semi-built crankshafts)

3.3.1 The stress concentration factor for bending (β_B) is:

$$\beta_B = 2,7146 \cdot f_B(s,w) \cdot f_B(w) \cdot f_B(b) \cdot f_B(r) \cdot f_B(d_G) \cdot f_B(d_H) \cdot f(\text{recess})$$

where:

$$f_B(s,w) = -1,7625 + 2,9821 \cdot w - 1,5276 \cdot w^2 + (1-s) \cdot (5,1169 - 5,8089 \cdot w + 3,1391 \cdot w^2) + (1-s)^2 \cdot (-2,1567 + 2,3297 \cdot w - 1,2952 \cdot w^2)$$

$$f_B(w) = 2,2422 \cdot w^{0,7548}$$

$$f_B(b) = 0,5616 + 0,1197 \cdot b + 0,1176 \cdot b^2$$

$$f_B(r) = 0,1908 \cdot r^{(-0,5568)}$$

$$f_B(d_G) = 1,0012 - 0,6441 \cdot d_G + 1,2265 \cdot d_G^2$$

$$f_B(d_H) = 1,0022 - 0,1903 \cdot d_H + 0,0073 \cdot d_H^2$$

$$f(\text{recess}) = 1 + (t_H + t_G) \cdot (1,8 + 3,2 \cdot s)$$

The stress concentration factor for compression (β_Q) due to the radial force is:

$$\beta_Q = 3,0128 \cdot f_Q(s) \cdot f_Q(w) \cdot f_Q(b) \cdot f_Q(r) \cdot f_Q(d_H) \cdot f(\text{recess})$$

where:

$$f_Q(s) = 0,4368 + 2,1630 \cdot (1-s) - (1,5212) \cdot (1-s)^2$$

$$f_Q(w) = \frac{w}{0,0637 + 0,9369 \cdot w}$$

$$f_Q(b) = -0,5 + b$$

$$f_Q(r) = 0,5331 \cdot r^{(-0,2038)}$$

$$f_Q(d_H) = 0,9937 - 1,1949 \cdot d_H + 1,7373 \cdot d_H^2$$

$$f(\text{recess}) = 1 + (t_H + t_G) \cdot (1,8 + 3,2 \cdot s)$$

The stress concentration factor for torsion (β_T) is:

$$\beta_T = \alpha_T$$

if the diameters and fillet radii of crankpin and journal are the same.

If crankpin and journal diameters and/or radii are of different sizes

$$\beta_T = 0,8 \cdot f(r,s) \cdot f(b) \cdot f(w)$$

where:

$f(r,s)$, $f(b)$ and $f(w)$ are to be determined in accordance with item [3.2] (see calculation of α_T); however, the radius of the journal fillet is to be related to the journal diameter :

$$r = \frac{R_G}{D_G}$$

3.4 Outlet of the crankpin oil bore

3.4.1 The stress concentration factor for bending (γ_B) is:

$$\gamma_B = 3 - 5,88 \cdot d_o + 34,6 \cdot d_o^2$$

The stress concentration factor for torsion (γ_T) is:

$$\gamma_T = 4 - 6 \cdot d_o + 30 \cdot d_o^2$$

4 Additional bending stresses

4.1 General

4.1.1 In addition to the alternating bending stresses in fillets (see item [2.1.3]), further bending stresses due to misalignment and bedplate deformation as well as due to axial and bending vibrations are to be considered by applying σ_{add} as given by Tab 3.

5 Calculation of equivalent alternating stress

5.1 General

5.1.1 In the fillets, bending and torsion lead to two different biaxial stress fields which can be represented by a Von Mises equivalent stress with the additional assumptions that bending and torsion stresses are time phased and the corre-

sponding peak values occur at the same location (see Tab 4).

As a result, the equivalent alternating stress is to be calculated for the crankpin fillet as well as for the journal fillet by using the Von Mises criterion.

At the oil hole outlet, bending and torsion lead to two different stress fields which can be represented by an equivalent principal stress equal to the maximum of principal stress resulting from the combination of these two stress fields with the assumption that bending and torsion are time phased (see Tab 5).

The above two different ways of equivalent stress evaluation both lead to stresses which may be compared to the same fatigue strength value of crankshaft assessed according to the Von Mises criterion.

5.2 Equivalent alternating stress

5.2.1 The equivalent alternating stress is calculated in accordance with the formulae given.

For the crankpin fillet:

$$\sigma_V = \pm \sqrt{(\sigma_{BH} + \sigma_{add})^2 + 3 \cdot \tau_H^2}$$

For the journal fillet:

$$\sigma_V = \pm \sqrt{(\sigma_{BG} + \sigma_{add})^2 + 3 \cdot \tau_G^2}$$

For the outlet of the crankpin oil bore:

$$\sigma_V = \pm \frac{1}{3} \sigma_{BO} \cdot \left[1 + 2 \sqrt{1 + \frac{9}{4} \cdot \left(\frac{\sigma_{TO}}{\sigma_{BO}} \right)^2} \right]$$

where:

σ_V [N/mm²] : equivalent alternating stress.

For other parameters see [2.1.3], [2.2.3] and [4].

Table 3

Type of engine	σ_{add} [N/mm ²]
Crosshead engines	± 30 (1)
Trunk piston engines	± 10
(1) The additional stress of ± 30 N/mm ² is composed of two components: <ul style="list-style-type: none"> • an additional stress of ± 20 N/mm² resulting from axial vibration • an additional stress of ± 10 N/mm² resulting from misalignment / bedplate deformation. It is recommended that a value of ± 20 N/mm ² be used for the axial vibration component for assessment purposes where axial vibration calculation results of the complete dynamic system.(engine/shafting/gearing/propeller) are not available. Where axial vibration calculation results of the complete dynamic system are available, the calculated figures may be used instead.	

6 Calculation of fatigue strength

6.1 General

6.1.1 The fatigue strength is to be understood as that value of equivalent alternating stress (Von Mises) which a crankshaft can permanently withstand at the most highly stressed points. The fatigue strength may be evaluated by means of the following formulae.

Related to the crankpin diameter:

$$\sigma_{DW} = \pm K \cdot (0,42 \cdot \sigma_B + 39,3) \cdot \left[0,264 + 1,073 \cdot D^{-0,2} + \frac{785 - \sigma_B}{4900} + \frac{196}{\sigma_B} \cdot \sqrt{\frac{1}{R_X}} \right]$$

with:

$R_X = R_H$ in the fillet area

$R_X = D_0 / 2$ in the oil bore area

Related to the journal diameter:

$$\sigma_{DW} = \pm K \cdot (0,42 \cdot \sigma_B + 39,3) \cdot \left[0,264 + 1,073 \cdot D_G^{-0,2} + \frac{785 - \sigma_B}{4900} + \frac{196}{\sigma_B} \cdot \sqrt{\frac{1}{R_G}} \right]$$

where:

σ_{DW} [N/mm²]: allowable fatigue strength of crankshaft

K [-] : factor for different types of crankshafts without surface treatment. Values greater than 1 are only applicable to fatigue strength in the fillet area.

$K = 1,05$ for continuous grain flow forged or drop-forged crankshafts

$K = 1,0$ for free form forged crankshaft (without continuous grain flow)

Factor for cast steel crankshafts with cold rolling treatment in fillet area

$K = 0,93$ for cast steel crankshafts manufactured by companies using a classification society approved cold rolling process

σ_B [N/mm²]: minimum tensile strength of crankshaft material.

For other parameters see [3.3].

When a surface treatment process is applied, it is to be approved by the Society.

These formulae are subject to the following conditions:

- surfaces of the fillet, the outlet of the oil bore and inside the oil bore (down to a minimum depth equal to 1,5 times the oil bore diameter) are to be smoothly finished.
- for calculation purposes R_H , R_G or R_X are to be taken as not less than 2 mm.

As an alternative, the fatigue strength of the crankshaft can be determined by experiment based either on a full size crankthrow (or crankshaft) or on specimens taken from a full size crankthrow.

In any case, the experimental procedure for fatigue evaluation of specimens and fatigue strength of crankshaft assess-

ment is to be submitted for approval to the Society (method, type of specimens, number of specimens (or crankthrows), number of tests, survival probability, confidence number).

7 Acceptability criteria

7.1 General

7.1.1 The sufficient dimensioning of a crankshaft is confirmed by a comparison of the equivalent alternating stress and the fatigue strength. This comparison is to be carried out for the crankpin fillet, the journal fillet and the outlet of the crankpin oil bore and is based on the formula:

$$Q = \frac{\sigma_{DW}}{\sigma_V}$$

where:

Q [-] : acceptability factor

Adequate dimensioning of the crankshaft is ensured if the smallest of all acceptability factors satisfies the criteria:

$$Q \geq 1,15$$

8 Calculation of shrink-fits of semi-built crankshafts

8.1 General

8.1.1 All crank dimensions necessary for the calculation of the shrink-fit are shown in Fig 5, where:

D_A [mm]: outside diameter of web or twice the minimum distance x between centreline of journals and outer contour of web, whichever is the lesser

D_S [mm]: shrink diameter

D_G [mm]: journal diameter

D_{BG} [mm]: diameter of axial bore in journal

L_S [mm]: length of shrink-fit

R_G [mm]: fillet radius of journal

y [mm]: distance between the adjacent generating lines of journal and pin $y \geq 0,05 \cdot D_S$

Where y is less than $0,1 \cdot D_S$ special consideration is to be given to the effect of the stress due to the shrink-fit on the fatigue strength at the crankpin fillet.

Respecting the radius of the transition from the journal to the shrink diameter, the following is to be complied with:

$$R_G \geq 0,015 \cdot D_G$$

and

$$R_G \geq 0,5 \cdot (D_S - D_G)$$

where the greater value is to be considered.

The actual oversize Z of the shrink-fit is to be within the limits Z_{min} and Z_{max} calculated in accordance with items [8.3] and [8.4].

Where the condition in [8.2] cannot be fulfilled, then calculation methods of Z_{min} and Z_{max} in [8.3] and [8.4] are not applicable due to multizone-plasticity problems.

In such case Z_{min} and Z_{max} are to be established based on FEM calculations.

Figure 5 : Crankthrow of semi-built crankshaft

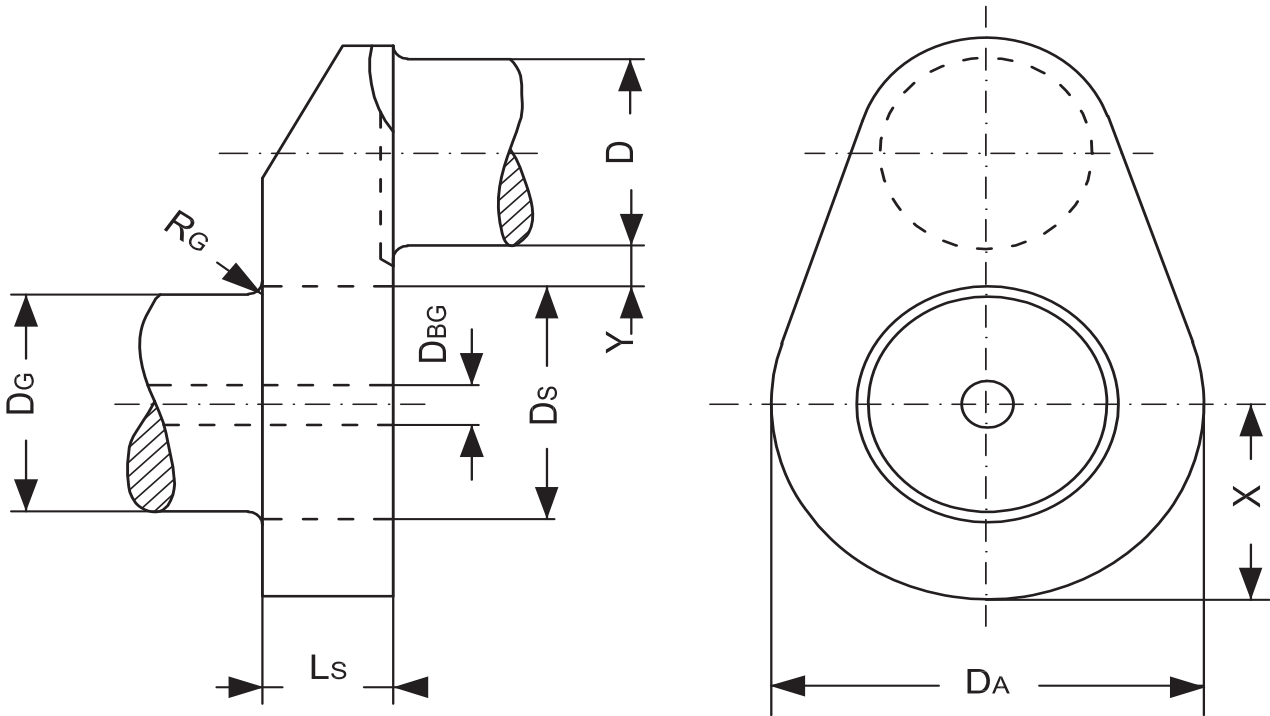

8.2 Maximum permissible hole in the journal pin

8.2.1 The maximum permissible hole diameter in the journal pin is calculated in accordance with the following formula:

$$D_{BG} = D_S \cdot \sqrt{1 - \frac{4000 \cdot S_R \cdot M_{max}}{\mu \cdot \pi \cdot D_S^2 \cdot L_S \cdot \sigma_{SP}}}$$

where:

S_R [-] : safety factor against slipping; however a value not less than 2 is to be taken unless documented by experiments

M_{max} [Nm]: absolute maximum value of the torque M_{Tmax} in accordance with [2.2.2].

μ [-] : coefficient for static friction; however a value not greater than 0,2 is to be taken unless documented by experiments

σ_{SP} [N/mm²]: minimum yield strength of material for journal pin.

This condition serves to avoid plasticity in the hole of the journal pin.

8.3 Necessary minimum oversize of shrink-fit

8.3.1 The necessary minimum oversize is determined by the greater value calculated according to:

$$Z_{min} \geq \frac{\sigma_{SW} \cdot D_S}{E_m}$$

and

$$Z_{min} \geq \frac{4000}{\mu \cdot \pi} \cdot \frac{S_R \cdot M_{max}}{E_m \cdot D_S \cdot L_S} \cdot \frac{1 - (Q_A^2 \cdot Q_S^2)}{(1 - Q_A^2) \cdot (1 - Q_S^2)}$$

where:

Z_{min} [mm]: minimum oversize

E_m [N/mm²]: Young's modulus

σ_{SW} [N/mm²]: minimum yield strength of material for crank web

Q_A [-] : web ratio, $Q_A = D_S / D_A$

Q_S [-] : shaft ratio, $Q_S = D_{BG} / D_S$

8.4 Maximum permissible oversize of shrink-fit

8.4.1 The maximum permissible oversize is calculated according to:

$$Z_{max} \leq D_S \cdot \left(\frac{\sigma_{SW}}{E_m} + \frac{0,8}{1000} \right)$$

This condition serves to restrict the shrinkage induced mean stress in the fillet.

Table 4 : Definition of Stress Concentration Factors in crankshaft fillets

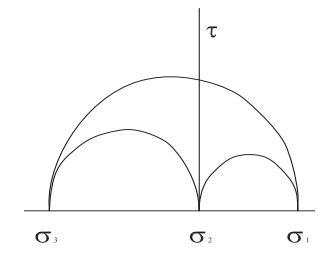
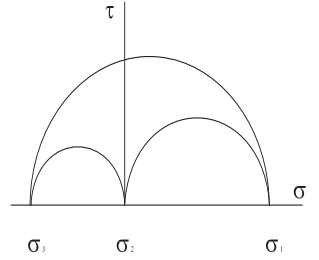
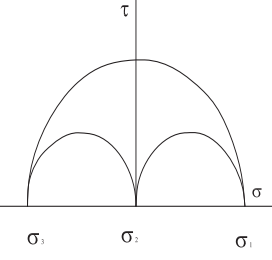
Stress		Max $\ \sigma_3\ $	Max σ_1	
Torsional loading	Location of maximal stresses	A	C	B
	Typical principal stress system Mohr's circle diagram with $\sigma_2 = 0$	 <p>$\ \sigma_3\ > \sigma_1$</p>	 <p>$\sigma_1 > \ \sigma_3\$</p>	 <p>$\sigma_1 = \ \sigma_3\$</p>
	Equivalent stress and S.C.F.	$\tau_{equiv} = \frac{\sigma_1 - \sigma_3}{2}$ $S.C.F. = \frac{\tau_{equiv}}{\tau_n} \text{ for } \alpha_T, \beta_T$		

Bending loading	Location of maximal stresses	B	B	B
	Typical principal stress system Mohr's circle diagram with $\sigma_3 = 0$	$\sigma \neq 0$ 		
	Equivalent stress and S.C.F.	$\sigma_{equiv} = \sqrt{\sigma_1^2 + \sigma_2^2 - \sigma_1 \cdot \sigma_2}$ $S.C.F. = \frac{\sigma_{equiv}}{\sigma_n} \text{ for } \alpha_B, \beta_B, \beta_Q$		

Table 5 : Stress Concentration Factors and stress distribution at the edge of oil drillings

d)

Stress type	Nominal stress tensor	Uniaxial stress distribution around the edge	Mohr's circle diagram
Tension	$\begin{bmatrix} \sigma_n & 0 \\ 0 & 0 \end{bmatrix}$	$\sigma_\alpha = \sigma_n \gamma_B / 3 [1 + 2 \cos(2\alpha)]$	$\gamma_B = (\sigma_{max} / \sigma_n) \text{ for } \alpha = k\pi$

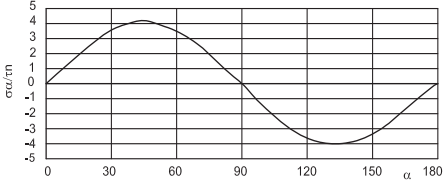
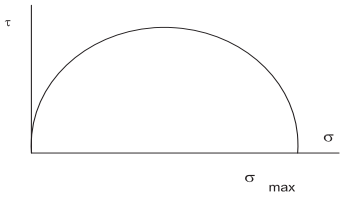
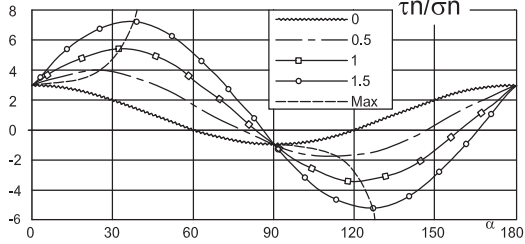
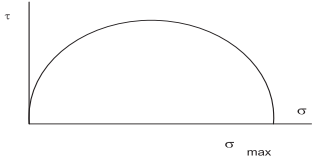
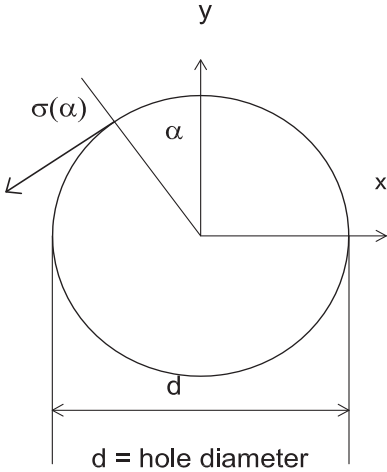
<p>Shear</p>	$\begin{bmatrix} 0 & \tau_n \\ \tau_n & 0 \end{bmatrix}$	$\sigma_\alpha = \gamma_T \tau_n \sin(2\alpha)$ 	 $\gamma_T = (\sigma_{\max}/\tau_n) \text{ for } \alpha = \frac{\pi}{4} + k\frac{\pi}{2}$
<p>Tension+ shear</p>	$\begin{bmatrix} \sigma_n & \tau_n \\ \tau_n & 0 \end{bmatrix}$	$\sigma_\alpha = \frac{\gamma_B}{3} \sigma_n \left\{ 1 + 2 \left[\cos(2\alpha) + \frac{3}{2} \frac{\gamma_T}{\gamma_B} \frac{\tau_n}{\sigma_n} \sin(2\alpha) \right] \right\}$ 	 $\sigma_{\max} = \frac{\gamma_B}{3} \sigma_n \left[1 + 2 \sqrt{1 + \frac{9}{4} \left(\frac{\gamma_T}{\gamma_B} \frac{\tau_n}{\sigma_n} \right)^2} \right]$ $\text{for } \alpha = \frac{1}{2} \text{tg}^{-1} \left(\frac{3}{2} \frac{\gamma_T}{\gamma_B} \frac{\tau_n}{\sigma_n} \right)$
 <p style="text-align: center;">$d = \text{hole diameter}$</p>			

9 Alternative method for calculation of Stress Concentration Factors in the web fillet radii of crankshafts by utilising the Finite Element Method

9.1 General

9.1.1

The objective of the analysis is to develop Finite Element Method (FEM) calculated figures as an alternative to the analytically calculated Stress Concentration Factors (SCF) at the crankshaft fillets.

The analytical method is based on empirical formulae developed from strain gauge measurements of various crank geometries and accordingly the application of these formulae is limited to those geometries.

The SCFs calculated according to this item [9] are defined as the ratio of stresses calculated by FEM to nominal stresses in both journal and pin fillets. When used in connection with the present method, Von Mises stresses shall be calculated for bending and principal stresses for torsion.

The procedure is valid for both solid cranks and semi-built cranks (except journal fillets).

The analysis is to be conducted as linear elastic FE analysis, and unit loads of appropriate magnitude are to be applied for all load cases.

The calculation of SCF at the oil bores is not covered by this item [9].

It is advised to check the element accuracy of the FE solver in use, e.g. by modelling a simple geometry and comparing the stresses obtained by FEM with the analytical solution for pure bending and torsion.

Boundary Element Method (BEM) may be used instead of FEM.

9.2 Model requirements

9.2.1

The basic recommendations and perceptions for building the FE model are presented in [9.2.2]. The final FE model is to fulfil the requirements in [9.2.3].

9.2.2 Element mesh recommendations

In order to fulfil the mesh quality criteria it is advisable to construct the FE model for the evaluation of Stress Concentration Factors according to the following recommendations:

- a) The model consists of one complete crank, from the main bearing centreline to the opposite side main bearing centreline
- b) Element types used in the vicinity of the fillets:
 - 10 node tetrahedral elements
 - 8 node hexahedral elements
 - 20 node hexahedral elements
- c) Mesh properties in fillet radii. The following applies to ± 90 degrees in the circumferential direction from the crank plane:
- d) Maximum element size $a=r/4$ through the entire fillet as well as in the circumferential direction. When using 20 node hexahedral elements, the element size in the circumferential direction may be extended up to $5a$. In the case of multi-radii fillet, r is the local fillet radius. (If 8 node hexahedral elements are used, even smaller element size is required to meet the quality criteria.)

- e) Recommended arrangement for element size in fillet depth direction:
 - First layer thickness equal to element size of a
 - Second layer thickness equal to element to size of $2a$
 - Third layer thickness equal to element to size of $3a$
- f) Minimum 6 elements across web thickness
- g) Generally the rest of the crank should be suitable for the numerical stability of the solver
- h) Counterweights need to be modelled only when influencing the global stiffness of the crank significantly
- i) Modelling of oil drillings is not necessary as long as the influence on global stiffness is negligible and the proximity to the fillet is more than $2r$; see Figure 6
- j) Drillings and holes for weight reduction are to be modelled
- k) Sub-modelling may be used as far as the software requirements are fulfilled.

Figure 6 : Oil bore proximity to fillet

9.2.3 Material

The formulae in [3] do not consider material properties such as Young's Modulus (E) and Poisson's ratio (ν). In FE analysis those material parameters are required, as strain is primarily calculated and stress is derived from strain using the Young's Modulus and Poisson's ratio. Reliable values for material parameters need to be used, either as quoted in the literature or as measured on representative material samples.

For steel the following is advised: $E= 2,05 \cdot 10^5$ MPa and $\nu=0,3$.

9.2.4 Element mesh quality criteria

If the actual element mesh does not fulfil any of the following criteria in the area examined for SCF evaluation, then a second calculation with a refined mesh is to be performed.

- a) Principal stresses criterion
The quality of the mesh should be assured by checking the stress component normal to the surface of the fillet radius. Ideally, this stress should be zero. With principal stresses σ_1 , σ_2 and σ_3 the following criterion is required:

$$\min(|\sigma_1|, |\sigma_2|, |\sigma_3|) < 0,03 \cdot \max(|\sigma_1|, |\sigma_2|, |\sigma_3|)$$

- b) Average/unaveraged stresses criterion

The criterion is based on observing the discontinuity of stress results over elements at the fillet for the calculation of SCF:

- Unaveraged nodal stress results calculated from each element connected to a node₁ should differ by less than 5% from the 100% averaged nodal stress results node₁ at this at the examined location.

9.3 Load cases

9.3.1

To replace the analytically determined SCF in [3], the following load cases are to be calculated.

9.3.2 Torsion

The structure is loaded in pure torsion. In the model, surface warp at the end faces is suppressed.

Torque is applied to the central node located at the crankshaft axis. This node acts as the master node with 6 degrees of freedom and is connected rigidly to all nodes of the end face.

Boundary and load conditions are valid for both in-line and V-type engines.

Figure 7 : Boundary and load conditions for the torsion load case

For all nodes in both the journal and crank pin fillet, principal stresses are extracted and the equivalent torsional stress is calculated:

$$\tau_{\text{equiv}} = \max\left(\frac{|\sigma_1 - \sigma_2|}{2}, \frac{|\sigma_2 - \sigma_3|}{2}, \frac{|\sigma_1 - \sigma_3|}{2}\right)$$

The maximum value taken for the subsequent calculation of the SCF:

$$\alpha_T = \frac{\tau_{\text{equiv},\alpha}}{\tau_N}$$

$$\beta_T = \frac{\tau_{\text{equiv},\beta}}{\tau_N}$$

where τ_N is nominal torsional stress referred to the crankpin or journal, respectively, as per [2.2.2] with the torsional torque T:

$$\tau_N = \frac{T}{W_p}$$

9.3.3 Pure bending (4 point bending)

The structure is loaded in pure bending. In the model surface, warp at the end faces is suppressed.

The bending moment is applied to the central node located at the crankshaft axis. This node acts as the master node with 6 degrees of freedom and is connected rigidly to all nodes of the end face.

Boundary and load conditions are valid for both in-line and V-type engines.

Figure 8 : Boundary and load conditions for the pure bending load case

For all nodes in both the journal and pin fillet, Von Mises equivalent stresses σ_{equiv} are extracted. The maximum value is used to calculate the SCF according to:

$$\sigma_B = \frac{\sigma_{\text{equiv},\alpha}}{\sigma_N}$$

$$\beta_B = \frac{\sigma_{\text{equiv},\beta}}{\sigma_N}$$

Nominal stress σ_N is calculated as per item b) of [2.1.2] with the bending moment M:

$$\sigma_N = \frac{M}{W_{\text{eqw}}}$$

9.3.4 Bending with shear force (3-point bending)

This load case is calculated to determine the SCF for pure transverse force (radial force, β_Q) for the journal fillet.

The structure is loaded in 3-point bending. In the model, surface warp at both end faces is suppressed. All nodes are connected rigidly to the centre node; boundary conditions are applied to the centre nodes. These nodes act as master nodes with 6 degrees of freedom.

The force is applied to the central node located at the pin centreline of the connecting rod. This node is connected to all nodes of the pin cross-sectional area. Warping of the sectional area is not suppressed.

Boundary and load conditions are valid for in-line and V-type engines. V-type engines can be modelled with one connecting rod force only. Using two connecting rod forces will make no significant change in the SCF.

Figure 9 : Boundary and load conditions for the 3-point bending load case of an in-line engine

$$\sigma_{3P} = \sigma_{N3P} \cdot \beta_B + \sigma_{Q3P} \cdot \beta_Q$$

where:

σ_{3P} : as found by the FE calculation

σ_{N3P} : Nominal bending stress in the web centre due to the force F_{3P} [N] applied to the centreline of the actual connecting rod; see Fig 10

β_B : as determined in [9.3.3]

$\sigma_{Q3P} = Q_{3P} / (B \cdot W)$ where Q_{3P} is the radial (shear) force in the web due to the force F_{3P} [N] applied to the centreline of the actual connecting rod; see also Fig 1.

b) Method 2

In a statically determined system with one crank throw supported by two bearings, the bending moment and radial (shear) force are proportional. Therefore the journal fillet SCF can be found directly by the 3-point bending FE calculation.

The SCF is then calculated according to

$$\beta_{BQ} = \frac{\sigma_{3P}}{\sigma_{N3P}}$$

For symbols, see item a) above.

When using this method, the radial force and stress determination become superfluous. The alternating bending stress in the journal fillet as per [2.1.3] is then evaluated:

$$\sigma_{BG} = \pm |\beta_{BQ} \cdot \sigma_{BFN}|$$

Note that the use of this method does not apply to the crankpin fillet and that this SCF must not be used in connection with calculation methods other than those assuming a statically determined system.

Figure 10 : Boundary and load conditions for the 3-point bending load case of an in-line engine

The maximum equivalent Von Mises stress σ_{3P} in the journal fillet is evaluated. The SCF in the journal fillet can be determined in two ways as shown in a) and b) below.

a) Method 1

The results from 3-point and 4-point bending are combined as follows:

APPENDIX 2

PLASTIC PIPES

1 General

1.1 Application

1.1.1 These requirements are applicable to all piping systems with parts made of rigid plastic.

1.1.2 Piping systems made of thermoplastic materials, such as polyethylene(PE), polypropylene(PP), and polybutylene (PB), and intended for non-essential services are to meet the requirements of recognised standards as well as [2.1.2], [2.3.4], [2.4.2], [3] and [4].

1.2 Use of plastic pipes

1.2.1 Plastic may be used in piping systems in accordance with the provisions of Sec 8, [2.1.3, provided the following requirements are complied with.

1.2.2 Plastic pipes are to be type approved by the Society.

1.3 Definitions

1.3.1 Plastic

Plastic includes both thermoplastic and thermosetting plastic materials with or without reinforcement, such as PVC and FRP (reinforced plastics pipes).

1.3.2 Piping systems

Piping systems means those made of plastic and include the pipes, fittings, joints, and any internal or external liners, coverings and coatings required to comply with the performance criteria.

1.3.3 Joints

Joints include all pipe assembling devices or methods, such as adhesive bonding, laminating, welding, etc.

1.3.4 Fittings

Fittings include bends, elbows, fabricated branch pieces, etc. made of plastic materials.

1.3.5 Nominal pressure

Nominal pressure is the maximum permissible working pressure which is to be determined in accordance with [2.2.2]

1.3.6 Design pressure

Design pressure is the maximum working pressure which is expected under operation conditions or the highest set pressure of any safety valve or pressure relief device on the system, if fitted.

1.3.7 Fire endurance

Fire endurance is the capability of the piping system to perform its intended function, i.e. maintain its strength and

integrity, for some predicted period of time while exposed to fire.

2 Design of plastic piping systems

2.1 General

2.1.1 Specification

The specification of the plastic piping is to be submitted in accordance with the provisions of Sec 8, [1.2.2]. It is to comply with a recognised national or international standard approved by the Society. In addition, the requirements stated below are to be complied with.

2.1.2 Marking

Plastic pipes and fittings are to be permanently marked with identification, including:

- pressure ratings
- the design standards that the pipe or fitting is manufactured in accordance with
- the material of which the pipe or fitting is made.

2.2 Strength

2.2.1 General

- a) The piping is to have sufficient strength to take account of the most severe concomitant conditions of pressure, temperature, the weight of the piping itself and any static and dynamic loads imposed by the design or environment.
- b) The maximum permissible working pressure is to be specified with due regard for the maximum possible working temperature in accordance with manufacturer's recommendations.

2.2.2 Permissible pressure

Piping systems are to be designed for a nominal pressure determined from the following conditions:

a) Internal pressure

The nominal internal pressure is not to exceed the smaller of:

- $P_{sth}/4$
- $P_{lth}/2,5$

where:

- P_{sth} : Short-term hydrostatic test failure pressure, in MPa
- P_{lth} : Long-term hydrostatic test failure pressure (>100 000 hours), in MPa.

- b) External pressure (to be considered for any installation subject to vacuum conditions inside the pipe or a head of liquid acting on the outside of the pipe)

The nominal external pressure is not to exceed $P_{col}/3$, where:

P_{col} : Collapse pressure

Note 1: The external pressure is the sum of the vacuum inside the pipe and the static pressure head outside the pipe.

- c) The collapse pressure is not to be less than 0,3 MPa.

2.2.3 Permissible temperature

- a) In general, plastic pipes are not to be used for media with a temperature above 60°C or below 0°C, unless satisfactory justification is provided to the Society.
- b) The permissible working temperature range depends on the working pressure and is to be in accordance with manufacturer's recommendations.
- c) The maximum permissible working temperature is to be at least 20°C lower than the minimum heat distortion temperature of the pipe material, determined according to ISO 75 method A or equivalent.
- d) The minimum heat distortion temperature is not to be less than 80°C.

2.2.4 Axial strength

- a) The sum of the longitudinal stresses due to pressure, weight and other loads is not to exceed the allowable stress in the longitudinal direction.
- b) In the case of fibre reinforced plastic pipes, the sum of the longitudinal stresses is not to exceed half of the nominal circumferential stress derived from the nominal internal pressure condition (see [2.2.2]).

2.2.5 Impact resistance

Plastic pipes and joints are to have a minimum resistance to impact in accordance with a recognised national or international standard.

2.3 Requirements depending on service and/or location

2.3.1 Fire endurance

The requirements for fire endurance of plastic pipes and their associated fittings are given in Tab 1 for the various systems and locations where the pipes are used.

Specifically:

- a 60 min fire endurance test in dry conditions is to be carried out according to Appendix 1 of IMO Res. A.753(18), where indicated "L1" in Tab 1
- a 30 min fire endurance test in dry conditions is to be carried out according to Appendix 1 of IMO Res. A.753(18), where indicated "L2" in Tab 1
- a 30 min fire endurance test in wet conditions is to be carried out according to Appendix 2 of IMO Res. A.753(18), where indicated "L3" in Tab 1
- no fire endurance test is required, where indicated "0" in Tab 1
- a metallic material with a melting point greater than 925°C is to be used, where indicated "X" in Tab 1.

Note 1: "NA" means "not applicable".

2.3.2 Flame spread

- a) All pipes, except those fitted on open decks and within tanks, cofferdams, pipe tunnels and ducts, are to have low spread characteristics not exceeding average values listed in IMO Resolution A.653(16).
- b) Surface flame characteristics are to be determined using the procedure given in IMO Res. A.653(16) with regard to the modifications due to the curvilinear pipe surfaces as listed in Appendix 3 of Res. A.753(18).
- c) Surface flame spread characteristics may also be determined using the text procedures given in ASTM D635, or other national equivalent standards.

2.3.3 Fire protection coating

Where a fire protective coating of pipes and fittings is necessary for achieving the fire endurance level required, it is to meet the following requirements:

- The pipes are generally to be delivered from the manufacturer with the protective coating on.
- The fire protection properties of the coating are not to be diminished when exposed to salt water, oil or bilge slops. It is to be demonstrated that the coating is resistant to products likely to come into contact with the piping.
- In considering fire protection coatings, such characteristics as thermal expansion, resistance against vibrations and elasticity are to be taken into account.
- The fire protection coatings are to have sufficient resistance to impact to retain their integrity.

2.3.4 Electrical conductivity

- a) Piping systems conveying fluids with a conductivity less than 1000 pS/m ($1\text{pS/m}=10^{-12}$ siemens per meter), such as refined products and distillates, are to be made of conductive pipes.
- b) Regardless of the fluid to be conveyed, plastic pipes passing through hazardous areas are to be electrically conductive.
- c) Where electrical conductivity is to be ensured, the resistance of the pipes and fittings is not to exceed:
 1×10^5 Ohm/m.
- d) It is preferred that pipes and fittings be homogeneously conductive. Where pipes and fittings are not homogeneously conductive, conductive layers are to be provided, suitably protected against the possibility of spark damage to the pipe wall.
- e) Satisfactory earthing is to be provided.

2.4 Pipe and fitting connections

2.4.1 General

- a) The strength of connections is not to be less than that of the piping system in which they are installed.
- b) Pipes and fittings may be assembled using adhesive-bonded, welded, flanged or other joints.
- c) When used for joint assembly, adhesives are to be suitable for providing a permanent seal between the pipes

and fittings throughout the temperature and pressure range of the intended application.

- d) Tightening of joints, where required, is to be performed in accordance with the manufacturer's instructions.
- e) Procedures adopted for pipe and fitting connections are to be submitted to the Society for approval, prior to commencing the work.

Table 1 : Fire endurance of piping systems

PIPING SYSTEM	LOCATION										
	Machinery spaces of category A (10)	Other machinery spaces and pump rooms (11)	Cargo pump rooms (12)	Ro/ro cargo holds (13)	Other dry cargo holds (14)	Cargo tanks (15)	Fuel oil tanks (16)	Ballast water tanks (17)	Coffer-dams, void spaces, pipe tunnels and ducts (18)	Accommodation, service and control spaces (19)	Open decks (20)
CARGO (FLAMMABLE CARGOES WITH FLASH POINT ≤ 60°C)											
Cargo lines	NA	NA	L1	NA	NA	0	NA	0 (9)	0	NA	L1 (2)
Crude oil washing lines	NA	NA	L1	NA	NA	0	NA	0 (9)	0	NA	L1 (2)
Vent lines	NA	NA	NA	NA	NA	0	NA	0 (9)	0	NA	X
INERT GAS											
Water seal effluent line	NA	NA	0 (1)	NA	NA	0 (1)	0 (1)	0 (1)	0 (1)	NA	0
Scrubber effluent line	0 (1)	0 (1)	NA	NA	NA	NA	NA	0 (1)	0 (1)	NA	0
Main line	0	0	L1	NA	NA	NA	NA	NA	0	NA	L1 (6)
Distribution line	NA	NA	L1	NA	NA	0	NA	NA	0	NA	L1 (2)
FLAMMABLE LIQUIDS (FLASH POINT > 60°C)											
Cargo lines	X	X	L1	X	X	NA (3)	0	0 (9)	0	NA	L1
Fuel oil	X	X	L1	X	X	NA (3)	0	0	0	L1	L1
Lubricating oil	X	X	L1	X	X	NA	NA	NA	0	L1	L1
Hydraulic oil	X	X	L1	X	X	0	0	0	0	L1	L1
SEA WATER (1)											
Bilge main and branches	L1	L1	L1	X	X	NA	0	0	0	NA	L1
Fire main and water spray	L1	L1	L1	X	NA	NA	NA	0	0	X	L1
Foam system	L1	L1	L1	NA	NA	NA	NA	NA	0	L1	L1
Sprinkler system	L1	L1	L3	X	NA	NA	NA	0	0	L3	L3
Ballast	L3	L3	L3	L3	X	0 (9)	0	0	0	L2	L2
Cooling water, essential services	L3	L3	NA	NA	NA	NA	NA	0	0	NA	L2
Tank cleaning services, fixed machines	NA	NA	L3	NA	NA	0	NA	0	0	NA	L3 (2)
Non-essential systems	0	0	0	0	0	NA	0	0	0	0	0
FRESH WATER											

PIPING SYSTEM	LOCATION										
	Machinery spaces of category A (10)	Other machinery spaces and pump rooms (11)	Cargo pump rooms (12)	Ro/ro cargo holds (13)	Other dry cargo holds (14)	Cargo tanks (15)	Fuel oil tanks (16)	Ballast water tanks (17)	Cofferdams, void spaces, pipe tunnels and ducts (18)	Accommodation, service and control spaces (19)	Open decks (20)
Cooling water, essential services	L3	L3	NA	NA	NA	NA	0	0	0	L3	L3
Condensate return	L3	L3	L3	0	0	NA	NA	NA	0	0	0
Non-essential systems	0	0	0	0	0	NA	0	0	0	0	0
SANITARY, DRAINS, SCUPPERS											
Deck drains (internal)	L1 (4)	L1 (4)	NA	L1 (4)	0	NA	0	0	0	0	0
Sanitary drains (internal)	0	0	NA	0	0	NA	0	0	0	0	0
Scuppers and discharges (over-board)	0 (1) (7)	0 (1) (7)	0 (1) (7)	0 (1) (7)	0 (1) (7)	0	0	0	0	0 (1) (7)	0
SOUNDING, AIR											
Water tanks, dry spaces	0	0	0	0	0	0 (9)	0	0	0	0	0
Oil tanks (flash point > 60°C)	X	X	X	X	X	X (3)	0	0 (9)	0	X	X
MISCELLANEOUS											
Control air	L1 (5)	L1 (5)	L1 (5)	L1 (5)	L1 (5)	NA	0	0	0	L1 (5)	L1 (5)
Service air (non-essential)	0	0	0	0	0	NA	0	0	0	0	0
Brine	0	0	NA	0	0	NA	NA	NA	0	0	0

PIPING SYSTEM	LOCATION										
	Machinery spaces of category A (10)	Other machinery spaces and pump rooms (11)	Cargo pump rooms (12)	Ro/ro cargo holds (13)	Other dry cargo holds (14)	Cargo tanks (15)	Fuel oil tanks (16)	Ballast water tanks (17)	Cofferdams, void spaces, pipe tunnels and ducts (18)	Accommodation, service and control spaces (19)	Open decks (20)
Auxiliary low steam pressure ($\leq 0,7$ MPa)	L2	L2	0 (8)	0 (8)	0 (8)	0	0	0	0	0 (8)	0 (8)
<p>(1) Where non-metallic piping is used, remote controlled valves to be provided at ship side (valve is to be controlled from outside space).</p> <p>(2) Remote closing valves to be provided at the cargo tanks.</p> <p>(3) When cargo tanks contain flammable liquids with flash point > 60 °C, "0" may replace "NA" or "X".</p> <p>(4) For drains serving only the space concerned, "0" may replace "L1".</p> <p>(5) When controlling functions are not required by the Rules, "0" may replace "L1".</p> <p>(6) For pipes between machinery space and deck water seal, "0" may replace "L1".</p> <p>(7) Scuppers serving open decks in positions 1 and 2, as defined in Pt B, Ch 1, Sec 2, are to be "X" throughout unless fitted at the upper end with a means of closing capable of being operated from a position above the freeboard deck in order to prevent downflooding.</p> <p>(8) For essential services, such as fuel oil tank heating and ship's whistle, "X" is to replace "0".</p> <p>(9) For tankers required to comply with Pt E, Ch 1, Sec 4, [2.1.3], "NA" is to replace "0".</p> <p>(10) Machinery spaces of category A are defined in Sec 1, [1.4.1].</p> <p>(11) Spaces, other than category A machinery spaces and cargo pumps rooms, containing propulsion machinery, boilers, steam and internal combustion engines, generators and major electrical machinery, pumps, oil filling stations, refrigerating, stabilising, ventilation and air-conditioning machinery, and similar spaces, and trunks to such spaces.</p> <p>(12) Spaces containing cargo pumps, and entrances and trunks to such spaces.</p> <p>(13) Ro-ro cargo spaces and special category spaces are defined in Ch 4, Sec 1, [3].</p> <p>(14) All spaces other than ro-ro cargo holds used for non-liquid cargo and trunks to such spaces.</p> <p>(15) All spaces used for liquid cargo and trunks to such spaces.</p> <p>(16) All spaces used for fuel oil (excluding cargo tanks) and trunks to such spaces.</p> <p>(17) All spaces used for ballast water and trunks to such spaces.</p> <p>(18) Empty spaces between two bulkheads separating two adjacent compartments.</p> <p>(19) Accommodation spaces, service spaces and control stations are defined in Ch 4, Sec 1, [3].</p> <p>(20) Open decks are defined in Ch 4, Sec 1, [3].</p>											

2.4.2 Bonding of pipes and fittings

- a) The procedure for making bonds is to be submitted to the Society for qualification. It is to include the following:
- materials used
 - tools and fixtures
 - joint preparation requirements
 - cure temperature
 - dimensional requirements and tolerances
 - acceptance criteria for the test of the completed assembly.
- b) When a change in the bonding procedure may affect the physical and mechanical properties of the joints, the procedure is to be requalified.

3 Arrangement and installation of plastic pipes

3.1 General

3.1.1 Plastic pipes and fittings are to be installed in accordance with the manufacturer's guidelines.

3.2 Supporting of the pipes

3.2.1

- a) Selection and spacing of pipe supports in shipboard systems are to be determined as a function of allowable stresses and maximum deflection criteria.

b) The selection and spacing of pipe supports are to take into account the following data:

- pipe dimensions
- mechanical and physical properties of the pipe material
- mass of pipe and contained fluid
- external pressure
- operating temperature
- thermal expansion effects
- load due to external forces
- thrust forces
- water hammer
- vibrations
- maximum accelerations to which the system may be subjected.

Combinations of loads are also to be considered.

c) Support spacing is not to be greater than the pipe manufacturer's recommended spacing.

3.2.2 Each support is to evenly distribute the load of the pipe and its content over the full width of the support. Measures are to be taken to minimise wear of the pipes where they are in contact with the supports.

3.2.3 Heavy components in the piping system such as valves and expansion joints are to be independently supported.

3.3 Provision for expansion

3.3.1 Suitable provision is to be made in each pipeline to allow for relative movement between pipes made of plastic and the steel structure, having due regard to:

- the high difference in the coefficients of thermal expansion
- deformations of the ship's structure.

3.3.2 Calculations of the thermal expansions are to take into account the system working temperature and the temperature at which the assembly is performed.

3.4 External loads

3.4.1 When installing the piping, allowance is to be made for temporary point loads, where applicable. Such allowance is to include at least the force exerted by a load (person) of 100 kg at mid-span on any pipe of more than 100 mm nominal outside diameter.

3.4.2 Pipes are to be protected from mechanical damage where necessary.

3.4.3 As well as providing adequate robustness for all piping, including open-ended piping, the minimum wall thickness complying with [2.2.2] a) may be increased at the request of the Society taking into account the conditions encountered during service on board ships.

3.5 Earthing

3.5.1 Where, in pursuance of [2.3.4], pipes are required to be electrically conductive, the resistance to earth from any point in the piping system is not to exceed 1×10^6 ohm.

3.5.2 Where provided, earthing wires are to be accessible for inspection.

3.6 Penetration of fire divisions and watertight bulkheads or decks

3.6.1 Where plastic pipes pass through "A" or "B" class divisions, arrangements are to be made to ensure that fire endurance is not impaired. These arrangements are to be tested in accordance with "Recommendations for Fire Test Procedures for "A", "B" and "F" Bulkheads" (IMO Resolution A754 (18) as amended).

3.6.2 When plastic pipes pass through watertight bulkheads or decks, the watertight integrity of the bulkhead or deck is to be maintained. If the bulkhead or deck is also a fire division and destruction by fire of plastic pipes may cause the inflow of liquid from tanks, a metallic shut-off valve operable from above the freeboard deck is to be fitted at the bulkhead or deck.

3.7 Systems connected to the hull

3.7.1 Bilge and sea water systems

a) Where, in pursuance of [2.3.1], plastic pipes are permitted in bilge and sea water systems, the ship side valves required in Sec 8, [2.8] and, where provided, the connecting pipes to the shell are to be made of metal in accordance with Sec 8, [2.1].

b) Ship side valves are to be provided with remote control from outside the space concerned. See Tab 1, footnote (1).

3.7.2 Scuppers and sanitary discharges

a) Where, in pursuance of [2.3.1], plastic pipes are permitted in scuppers and sanitary discharge systems connected to the shell, their upper end is to be fitted with closing means operated from a position above the freeboard deck in order to prevent downflooding. See Tab 1, footnotes (1) and (7).

b) Discharge valves are to be provided with remote control from outside the space concerned.

3.8 Application of fire protection coatings

3.8.1 Where necessary for the required fire endurance as stated in [2.3.3], fire protection coatings are to be applied on the joints, after performing hydrostatic pressure tests of the piping system.

3.8.2 The fire protection coatings are to be applied in accordance with the manufacturer's recommendations, using a procedure approved in each case.

4 Certification, inspection and testing of plastic piping

4.1 Certification

4.1.1 Type approval

Plastic pipes, fittings, joints and any internal or external liners, coverings and coatings are to be of a type approved by the Society for the intended use according to the Rules for Type Approval of Plastic Pipes.

4.1.2 Bonding qualification test

- a) A test assembly is to be fabricated in accordance with the procedure to be qualified. It is to consist of at least one pipe-to-pipe joint and one pipe-to-fitting joint.
- b) When the test assembly has been cured, it is to be subjected to a hydrostatic test pressure at a safety factor of 2,5 times the design pressure of the test assembly, for not less than one hour. No leakage or separation of joints is allowed. The test is to be conducted so that the joint is loaded in both longitudinal and circumferential directions.
- c) Selection of the pipes used for the test assembly is to be in accordance with the following:
 - when the largest size to be joined is 200 mm nominal outside diameter or smaller, the test assembly is to be the largest piping size to be joined.
 - when the largest size to be joined is greater than 200 mm nominal outside diameter, the size of the test assembly is to be either 200 mm or 25% of the largest piping size to be joined, whichever is the greater.

4.2 Workshop tests

4.2.1 Each pipe and fitting is to be tested by the manufacturer at a hydrostatic pressure not less than 1,5 times the nominal pressure.

Alternatively, for pipes and fittings not employing hand lay-up techniques, the hydrostatic pressure test may be carried out in accordance with the hydrostatic testing requirements stipulated in the recognised national or international standard to which the pipes or fittings are manufactured, provided that there is an effective quality system in place.

4.2.2 The manufacturer is to have quality system that meets ISO 9000 series standards or equivalent.

The quality system is to consist of elements necessary to ensure that pipes and fittings are produced with consistent and uniform mechanical and physical properties.

4.2.3 In case the manufacturer does not have an approved quality system complying with ISO 9000 series or equivalent, pipes and fittings are to be tested in accordance with these requirements to the Surveyor's satisfaction for every batch of pipes.

Depending upon the intended application, the Society may require the pressure testing of each pipe and/or fitting.

4.3 Testing after installation on board

4.3.1 Hydrostatic testing

- a) Piping systems for essential systems are to be subjected to a test pressure of not less than 1,5 times the design pressure or 0,4 MPa, whichever is the greater.
- b) Piping systems for non-essential services are to be checked for leakage under operational conditions.

4.3.2 Earthing test

For piping required to be electrically conductive, earthing is to be checked and random resistance testing is to be performed.

APPENDIX 3

INDEPENDENT FUEL OIL TANKS

1 General

1.1 Application

1.1.1

- The provisions of this Appendix apply to fuel oil tanks and bunkers which are not part of the ship's structure.
- Requirements for scantling apply only to steel tanks. Scantling of tanks not made of steel will be given special consideration.

1.2 Documents to be submitted

1.2.1 Constructional drawings of the tanks are to be submitted, showing the height of the overflow and air pipe above the top of the tank.

1.3 Symbols and units

1.3.1 Tanks

The meaning of the symbols used for tanks is given in Fig 1.

Figure 1 : Symbols used for tanks

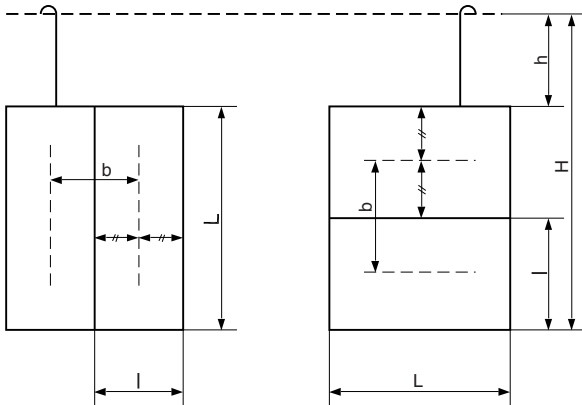

- L** : Greater length of the considered plating element, in m
- l** : Smaller length of the considered plating element, in m
- H** : Height, in m, of the overflow or air pipe above the lower edge of the considered plating element
- h** : Height, in m, of overflow or air pipe above the top of the tank, subject to a minimum of:
- 3,60 m for fuel oil having a flash point below 60°C,
 - 2,40 m otherwise.

1.3.2 Stiffeners

The following symbols and units are used for the stiffeners:

- b** : Width of the plating element supported by the stiffener, in m
- w** : Section modulus of the stiffeners, in cm³.

2 Design and installation of tanks

2.1 Materials

2.1.1 General

Independent fuel oil tanks are to be made of steel except where permitted in [2.1.2].

2.1.2 Use of materials other than steel

- On ships of less than 100 tons gross tonnage, independent fuel oil tanks may be made of:
 - aluminium alloys or equivalent material, provided that the tanks are located outside the propulsion machinery spaces or, when located within such spaces, they are insulated to A-60 class standard
 - glass reinforced plastics (GRP), provided:
 - the total volume of tanks located in the same space does not exceed 4,5 m³, and
 - the properties of GRP including fire resistance comply with the relevant provisions of App 3.
- On ships of 100 tons gross tonnage or more, the use of independent fuel oil tanks made of aluminium alloys or GRP will be given special consideration.

2.2 Scantling of steel tanks

2.2.1 General

- The scantling of tanks whose dimensions are outside the range covered by the following provisions will be given special consideration.
- The scantling of the tanks is to be calculated assuming a minimum height *h* of the overflow or air pipe above the top of the tank of:
 - 3,60 m for fuel oil having a flash point below 60°C,
 - 2,40 m otherwise.
- All tanks having plating elements of a length exceeding 2,5 m are to be fitted with stiffeners.

2.2.2 Thickness of plating

The thickness of the plates is not to be less than the value given in Tab 1 for the various values of *l*, *l/l* and *H*. However, for tanks having a volume of more than 1 m³, the thickness of the plates is not to be less than 5 mm.

2.2.3 Scantlings of stiffeners

- This requirement applies only to stiffeners which are all vertical or all horizontal and attached according to the

types shown in Fig 2. Other cases will be given special consideration.

- b) The minimum values of the ratio w/b required for stiffeners are given in:

- Tab 2 for vertical stiffeners
- Tab 3 for horizontal stiffeners

for the different types of attachments shown in Fig 2.

2.3 Installation

2.3.1 Securing

Independent tanks are to be securely fixed to hull structures and are to be so arranged as to permit inspection of adjacent structures.

2.3.2 Protection against spillage

Where permitted, independent fuel oil tanks are to be placed in an oil-tight spill tray of ample size with a suitable drain pipe leading to a suitably sized spill oil tank.

Table 1 : Thickness of plating (mm)

l (m)	L / l	H (m)													
		2,4 - 2,7	2,7 - 3,0	3,0 - 3,3	3,3 - 3,6	3,6 - 4,0	4,0 - 4,4	4,4 - 4,8	4,8 - 5,2	5,2 - 5,8	5,8 - 6,4	6,4 - 7,0	7,0 - 8,0	8,0 - 9,0	9,0 - 10,0
0,40	< 2	3,0	3,0	3,0	3,0	3,0	3,0	3,0	3,5	3,5	3,5	4,0	4,0	4,0	4,5
	≥ 2	3,0	3,0	3,0	3,5	3,5	3,5	4,0	4,0	4,0	4,5	4,5	5,0	5,0	5,5
0,45	< 2	3,0	3,0	3,0	3,0	3,0	3,5	3,5	3,5	4,0	4,0	4,0	4,5	4,5	5,0
	≥ 2	3,5	3,5	3,5	4,0	4,0	4,0	4,5	4,5	4,5	5,0	5,0	5,5	6,0	6,0
0,50	< 2	3,0	3,0	3,5	3,5	3,5	4,5	4,5	5,0	5,0	5,5	5,5	6,0	6,5	7,0
	≥ 2	3,5	4,0	4,0	4,0	4,5	4,5	4,5	5,0	5,0	5,5	5,5	6,0	6,5	7,0
0,55	< 2	3,5	3,5	3,5	4,0	4,0	4,0	4,0	4,5	4,5	5,0	5,0	5,5	5,5	6,0
	≥ 2	4,0	4,5	4,5	4,5	4,5	5,0	5,0	5,5	5,5	6,0	6,0	6,5	7,0	7,5
0,60	< 2	3,5	4,0	4,0	4,0	4,0	4,5	4,5	4,5	5,0	5,0	5,5	5,5	6,0	6,5
	≥ 2	4,5	4,5	4,5	5,0	5,0	5,5	5,5	6,0	6,0	6,5	6,5	7,0	7,5	8,0
0,65	< 2	4,0	4,0	4,0	4,0	4,5	4,5	5,0	5,0	5,5	5,5	6,0	6,0	6,5	7,0
	≥ 2	4,5	5,0	5,0	5,0	5,5	6,0	6,0	6,5	6,5	7,0	7,5	7,5	8,5	8,5
0,70	< 2	4,0	4,0	4,5	4,5	5,0	5,0	5,0	5,5	5,5	6,0	6,5	6,5	7,0	7,5
	≥ 2	5,0	5,0	5,5	5,5	6,0	6,5	6,5	7,0	7,0	7,5	8,0	8,5	9,0	---
0,75	< 2	4,5	4,5	5,0	5,0	5,0	5,5	5,5	6,0	6,0	6,5	6,5	7,0	7,5	8,0
	≥ 2	5,5	5,5	6,0	6,0	6,5	6,5	7,0	7,5	7,5	8,0	8,5	9,0	---	---
0,80	< 2	4,5	5,0	5,0	5,0	5,5	6,0	6,0	6,0	6,5	7,0	7,0	7,5	8,0	8,5
	≥ 2	5,5	6,0	6,0	6,5	6,5	7,0	7,5	7,5	8,0	8,5	9,0	---	---	---
0,85	< 2	5,0	5,0	5,5	5,5	5,5	6,0	6,5	6,5	7,0	7,0	7,5	8,0	8,5	9,0
	≥ 2	6,0	6,5	6,5	7,0	7,0	7,5	8,0	8,0	8,5	9,0	---	---	---	---
0,90	< 2	5,0	5,5	5,5	6,0	6,0	6,5	6,5	7,0	7,0	7,5	8,0	8,5	9,0	---
	≥ 2	6,5	6,5	7,0	7,0	7,5	8,0	8,5	8,5	9,0	---	---	---	---	---
0,95	< 2	5,5	5,5	6,0	6,0	6,5	7,0	7,0	7,5	7,5	8,0	8,5	9,0	---	---
	≥ 2	6,5	7,0	7,0	7,5	8,0	8,5	9,0	9,0	---	---	---	---	---	---
1,00	< 2	5,5	6,0	6,0	6,5	7,0	7,0	7,5	7,5	8,0	8,5	9,0	---	---	---
	≥ 2	7,0	7,5	7,5	8,0	8,5	8,5	9,0	---	---	---	---	---	---	---

Figure 2 : Type of stiffener end attachments

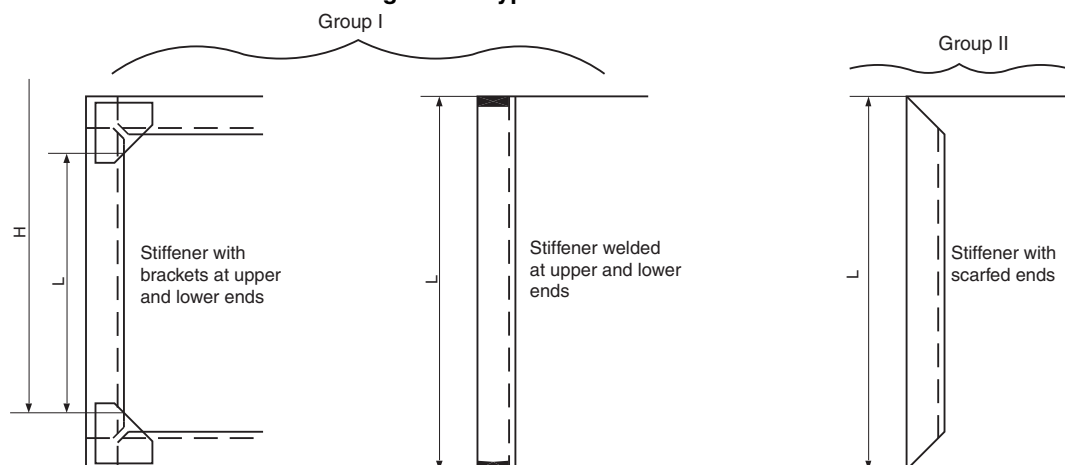

Table 2 : Values of w/b ratio for vertical stiffeners (cm³/m)

L (m)	end attachment	H, in m (1)													
		3,0	3,3	3,6	3,9	4,3	4,6	5,0	5,5	6,0	7,0	8,0	9,0	10,0	
0,6	I	5,0	5,5	6,0	6,5	7,5	8,0	9,0	9,5	10,5	11,5	14,0	16,0	18,0	
	II	8,0	9,0	10,0	11,0	12,0	12,5	13,0	15,0	16,0	19,0	22,0	25,0	28,0	
0,8	I	8,5	9,5	10,5	11,5	13,0	14,0	15,0	16,5	18,0	22,0	25,0	28,0	31,5	
	II	13,0	15,0	16,0	18,0	20,0	21,5	24,0	25,5	28,5	34,0	38,0	43,0	48,0	
1,0	I		14,5	16,0	17,5	19,5	21,0	23,0	26,0	28,5	34,0	38,0	43,0	49,0	
	II		22,0	24,0	27,0	30,0	32,5	36,0	39,0	43,0	51,0	58,0	67,0	75,0	
1,2	I			22,5	24,5	28,0	30,0	33,0	37,0	40,5	48,0	55,0	63,0	71,0	
	II			34,0	30,7	42,5	46,0	50,0	55,0	61,0	73,0	84,0	96,0	107	
1,4	I			30,0	32,5	37,0	40,0	44,0	49,0	55,0	65,0	75,0	85,0	96,0	
	II			45,0	49,0	56,0	61,0	67,0	74,0	82,0	98,0	113,0	129,0	144,0	
1,6	I				47,0	53,0	57,0	64,0	71,0	79,0	94,0	110,0	125,0	140,0	
	II				71,0	80,0	87,0	96,0	107,0	118,0	141,0	165,0	187,0		
1,8	I				58,0	65,0	71,0	79,0	88,0	98,0	117,0	136,0	156,0	175,0	
	II				87,0	98,0	107,0	118,0	132,0	147,0	176,0	204,0			
2,0	I					78,0	85,0	95,0	107,0	119,0	142,0	166,0	190,0		
	II					118,0	129,0	142,0	160,0	178,0					
2,2	I							100,0	112,0	126,0	140,0	170,0	198,0		
	II							151,0	168,0	190,0					
2,5	I							124,0	139,0	158,0					
	II							187,0							

(1) H is to be taken equal to the height of the tank top above the lower end of the stiffener, plus h.

Table 3 : Values of w/b ratio for horizontal and top and bottom stiffeners (cm³/m)

L (m)	end attachment	H, in m (1)															
		2,4	2,6	2,8	3,0	3,3	3,6	3,9	4,3	4,6	5,0	5,5	6,0	7,0	8,0	9,0	10,0
0,6	I	4,5	5,0	5,5	6,0	6,5	7,0	7,5	8,5	9,0	10,0	11,0	12,0	13,5	15,0	17,0	19,0
	II	7,0	8,0	8,5	9,0	10,0	11,0	11,5	12,5	13,5	15,0	16,0	17,5	21,0	24,0	27,0	30,0
0,8	I	8,0	9,0	9,5	10,0	11,0	12,0	13,0	14,5	15,5	17,0	18,5	20,0	23,5	27,0	30,0	33,5
	II	13,0	15,0	15,5	16,5	18,0	19,5	21,5	23,5	25,0	27,0	30,0	34,0	38,0	44,0	49,0	55,0
1,0	I	13,0	15,0	15,5	16,5	18,0	19,5	21,5	23,5	25,0	27,0	30,0	34,0	38,0	44,0	49,0	55,0
	II	20,0	22,0	23,5	25,0	28,0	30,0	33,0	36,0	39,0	42,0	46,0	50,0	59,0	67,0	75,0	84,0
1,2	I	18,0	20,0	21,0	22,5	25,0	26,5	29,5	32,5	34,5	37,5	41,5	45,0	52,5	60,0	67,5	75,0
	II	28,0	31,0	33,0	35,0	39,0	42,0	46,0	51,0	54,0	59,0	65,0	70,0	82,0	93,0	105	117
1,4	I	26,0	28,0	30,5	32,5	36,0	39,0	42,5	46,5	50,0	54,5	59,5	65,0	76,0	87,0	97,0	108
	II	39,0	43,0	45,5	49,0	54,0	58,5	63,5	70,0	75,0	81,0	89,0	97,0	113	130	146	162
1,6	I	36,0	39,0	42,0	45,0	50,0	54,0	59,0	65,0	69,0	75,0	82,0	90,0	105	120	135	150
	II	56,0	61,0	66,0	70,0	77,0	84,0	91,0	100	107	117	128	140	163	186		
1,8	I	46,0	50,0	54,0	58,0	63,0	69,0	75,0	82,0	88,0	95,0	105	115	134	153	172	191
	II	70,0	76,0	82,0	88,0	96,0	105	113	125	134	146	160	175	204			
2,0	I	57,0	62,0	67,0	72,0	78,0	85,0	92,0	102	109	118	130	142	166	190		
	II	87,0	95,0	102	109	120	130	141	155	166	181	198					
2,2	I	70,0	76,0	82,0	88,0	96,0	105	113	125	134	145	160	175	204			
	II	107	116	125	134	147	160	174	192	205							
2,5	I	92,0	100	108	115	127	138	150	165	176	191						
	II	140	152	163	175	192											

(1) For horizontal stiffeners, H is to be measured from the horizontal stiffener immediately below the stiffener considered. For top stiffeners, H = h.

APPENDIX 4

TYPE TEST PROCEDURE FOR CRANKCASE EXPLOSION RELIEF VALVES

1 General

1.1 Application

1.1.1 This test procedure applies to type approved crankcase explosion relief valves intended to be fitted to diesel engines as required under Sec 2, [2.3.4].

Note 1: Engines are to be fitted with components and arrangements complying with this Appendix when:

- the engine is installed on existing ships (i.e. ships for which the date of contract for construction is before 1 July 2008) and the date of application for certification of the engine (i.e. the date of whatever document the Society requires/accepts as an application or request for certification of an individual engine) is on or after 1 July 2008; or
- the engine is installed on new ships (i.e. ships for which the date of contract for construction is on or after 1 July 2008).

1.1.2 This test procedure is also applicable to explosion relief valves intended for gear cases.

1.1.3 Standard repeatable test conditions have been established using methane gas and air mixture.

1.1.4 The test procedure is only applicable to explosion relief valves fitted with flame arresters.

1.1.5 Where internal oil wetting of a flame arrester is a design feature of an explosion relief valve, alternative test arrangements that demonstrate compliance with these requirements may be proposed by the Manufacturer. The alternative test arrangements are to be agreed by the Society.

1.2 Recognised Standards

1.2.1

- a) EN 12874:2001: Flame arresters - Performance requirements, test methods and limits for use.
- b) ISO/IEC EN 17025:2005: General requirements for the competence of testing and calibration laboratories.
- c) EN 1070:1998: Safety of Machinery - Terminology.
- d) VDI 3673: Part 1: Pressure Venting of Dust Explosions.
- e) IMO MSC/Circular 677 - Revised Standards for the Design, Testing and Locating of Devices to Prevent the Passage of Flame into Cargo Tanks in Tankers.

1.3 Purpose

1.3.1 The purpose of type testing crankcase explosion relief valves is fourfold:

- a) To verify the effectiveness of the flame arrester.
- b) To verify that the valve closes after an explosion.
- c) To verify that the valve is gas/air tight after an explosion
- d) To establish the level of overpressure protection provided by the valve.

2 Test houses

2.1 General

2.1.1 The test houses for carrying out type testing of crankcase explosion relief valves are to meet the requirements given in [2.1.2] to [2.1.13].

2.1.2 The test houses where test is carried out are to be accredited to a national or international standard, e.g. ISO/IEC 17025.

2.1.3 The test houses are to be acceptable to the Society.

2.1.4 The test houses are to be equipped so that they can perform and record explosion testing in accordance with this procedure.

2.1.5 The test houses are to have equipment for controlling and measuring a methane gas in air concentration within a test vessel to an accuracy of $\pm 0,1\%$.

2.1.6 The test houses are to be capable of effective point located ignition of methane gas in air mixture.

2.1.7 The pressure measuring equipment is to be capable of measuring the pressure in the test vessel in at least two positions: one at the valve and the other at the test vessel centre. The measuring arrangements are to be capable of measuring and recording the pressure changes throughout an explosion test at a frequency recognising the speed of events during an explosion. The result of each test is to be documented by video recording and by recording with a heat sensitive camera.

2.1.8 The test vessel for explosion testing is to have documented dimensions. The dimensions are to be such that the vessel is not "pipe like" with the distance between dished ends being not more than 2,5 times its diameter. The internal volume of the test vessel is to include any standpipe arrangements.

2.1.9 The test vessel is to be provided with a flange, located centrally at one end perpendicular to the vessel lon-

itudinal axis for mounting the explosion relief valve. The test vessel is to be arranged in an orientation consistent with the way the valve will be installed in service, i.e. in the vertical plane or the horizontal plane.

2.1.10 A circular plate is to be provided for fitting between the pressure vessel flange and valve to be tested with the following dimensions:

- Outside diameter of 2 times the outer diameter of the valve top cover.
- Internal bore having the same internal diameter as the valve to be tested.
- Internal bore having the same internal diameter as the valve to be tested.

2.1.11 The test vessel is to have connections for measuring the methane in air mixture at the top and bottom.

2.1.12 The test vessel is to be provided with a means of fitting an ignition source at a position as specified in [3.1.3].

2.1.13 The test vessel volume is to be, as far as practicable, related to the size and capability of the relief valve to be tested. In general, the volume is to correspond to the requirement in Sec 2, [2.3.4] b) for the free area of explosion relief valve to be not less than 115cm²/m³ of crankcase gross volume.

This means that the testing of a valve having 1150 cm² of free area, would require a test vessel with a volume of 10m³.

Where the free area of relief valves is greater than 115 cm²/m³ of the crankcase gross volume, the volume of the test vessel is to be consistent with the design ratio.

In no case the volume of the test vessel is to vary by more than +15% to -15% from the design cm²/m³ volume ratio.

3 Explosion tests, assessment and design series qualifications

3.1 Process

3.1.1 All explosion tests to verify the functionality of crankcase explosion relief valves are to be carried out using an air and methane mixture with a volumetric methane concentration of 9,5% ±0,5%. The pressure in the test vessel is to be not less than atmospheric pressure and is not to exceed the opening pressure of the relief valve.

3.1.2 The concentration of methane in the test vessel is to be measured at the top and bottom of the vessel and these concentrations are not to differ by more than 0,5%.

3.1.3 The ignition of the methane and air mixture is to be made at the centreline of the test vessel at a position approximately one third of the height or length of the test vessel opposite to where the valve is mounted.

3.1.4 The ignition is to be made using a maximum 100 joule explosive charge.

3.2 Valves to be tested

3.2.1 The valves used for type testing (including the testing specified in item [3.2.3]) are to be selected from the Manufacturer's normal production line for such valves by the QSCS Classification Society (see Pt A, Ch 1, Sec 1, [1.2.1]) witnessing the tests.

3.2.2 For approval of a specific valve size, three valves are to be tested in accordance with [3.2.3] and [3.3]. For a series of valves, refer to [3.5].

3.2.3 The valves selected for type testing are to have been previously tested at the Manufacturer's works to demonstrate that the opening pressure is in accordance with the specification within a tolerance of ± 20% and that the valve is airtight at a pressure below the opening pressure for at least 30 seconds.

This test is to verify that the valve is airtight following assembly at the Manufacturer's works and that the valve begins to open at the required pressure demonstrating that the correct spring has been fitted.

3.2.4 The type testing of valves is to recognise the orientation in which they are intended to be installed on the engine or gear case. Three valves of each size are to be tested for each intended installation orientation, i.e. in the vertical and/or horizontal positions.

3.3 Method

3.3.1 The following requirements are to be satisfied at explosion testing:

- a) The explosion testing is to be witnessed by a QSCS Classification Society Surveyor (see Pt A, Ch 1, Sec 1, [1.2.1]).
- b) Where valves are to be installed on an engine or gear case with shielding arrangements to deflect the emission of explosion combustion products, the valves are to be tested with the shielding arrangements fitted.
- c) Successive explosion tests to establish a valve's functionality are to be carried out as quickly as possible during stable weather conditions.
- d) The pressure rise and decay during all explosion testing is to be recorded.
- e) The external condition of the valves is to be monitored during each test for indication of any flame release by video and heat sensitive camera.

3.3.2 The explosion testing is to be in three stages for each valve that is required to be approved as being type tested.

a) Stage 1:

Two explosion tests are to be carried out in the test vessel with the circular plate described in item [2.1.10] fitted and the opening in the plate covered by a 0,05mm thick polythene film. These tests establish a reference pressure level for determination of the capability of a relief valve in terms of pressure rise in the test vessel; see [3.4.1] f).

b) Stage 2:

- 1) Two explosion tests are to be carried out on three different valves of the same size. Each valve is to be mounted in the orientation for which approval is sought, i.e. in the vertical or horizontal position with the circular plate described in [2.1.10] located between the valve and pressure vessel mounting flange. The pressure rise is not to exceed the limit specified by the Manufacturer.
- 2) The first of the two tests on each valve is to be carried out with a 0,05 mm thick polythene bag enclosing the valve and circular plate; the bag is to have a minimum diameter of three times the diameter of the circular plate and volume not less than 30% of the test vessel. Before the explosion test is carried out, the polythene bag is to be empty of air. The polythene bag is required to provide a readily visible means of assessing whether there is flame transmission through the relief valve following an explosion consistent with the requirements of the standards identified in [1.2].

During the test, the explosion pressure will open the valve and some unburned methane/air mixture will be collected in the polythene bag. When the flame reaches the flame arrester and if there is flame transmission through the flame arrester, the methane/air mixture in the bag will be ignited and this will be visible.

- 3) Provided that the first explosion test successfully demonstrated that there was no indication of combustion outside the flame arrester and there are no visible signs of damage to the flame arrester or valve, a second explosion test without the polythene bag arrangement is to be carried out as soon as possible after the first test. During the second explosion test, the valve is to be visually monitored for any indication of combustion outside the flame arrester and video records are to be kept for subsequent analysis. The second test is required to demonstrate that the valve can still function in the event of a secondary crankcase explosion.
- 4) After each explosion, the test vessel is to be maintained in the closed condition for at least 10 seconds to enable the tightness of the valve to be ascertained. The tightness of the valve can be verified during the test from the pressure/time records or by a separate test after completing the second explosion test.

c) Stage 3:

Two further explosion tests are to be carried out as described in Stage 1. These further tests are required to provide an average baseline value for assessment of pressure rise recognising that the test vessel ambient conditions may have changed during the testing of the explosion relief valves in Stage 2.

3.4 Assessment and records

3.4.1 For the purposes of verifying compliance with the requirements of this appendix, the assessment and records

of the valves used for explosion testing are to address the following items a) to l).

- a) The valves to be tested are to have evidence of design appraisal/approval by the QSCS Classification Society (see Pt A, Ch 1, Sec 1, [1.2.1]) witnessing the testing.
- b) The designation, dimensions and characteristics of the valves to be tested are to be recorded. This is to include free area of the valve and the flame arrester and the amount of valve lift at 0,02 MPa.
- c) The test vessel volume is to be determined and recorded.
- d) For acceptance of the functioning of the flame arrester there is not to be any indication of flame or combustion outside the valve during an explosion test. This should be confirmed by the test laboratory taking into account measurements from the heat sensitive camera.
- e) The pressure rise and decay during an explosion are to be recorded with indication of the pressure variation showing the maximum overpressure and steady under pressure in the test vessel during testing. The pressure variation is to be recorded at two points in the pressure vessel.
- f) The effect of an explosion relief valve in terms of pressure rise following an explosion is ascertained from maximum pressures recorded at the centre of the test vessel during the three stages. The pressure rise within the test vessel due to the installation of a relief valve is the difference between the average pressure of the four explosions from Stages 1 and 3 and the average of the first tests on the three valves in Stage 2.
- g) The valve tightness is to be ascertained by verifying from the records at the time of testing that an under pressure of at least 0,03 MPa is held by the test vessel for at least 10 seconds following an explosion.
This test is to verify that the valve has effectively closed and is reasonably gas-tight following dynamic operation during an explosion.
- h) After each explosion test in Stage 2, the external condition of the flame arrester is to be examined for signs of serious damage and/or deformation that may affect the operation of the valve.
- i) After completion of the explosion tests, the valves are to be dismantled and the condition of all components ascertained and documented. In particular, any indication of valve sticking or uneven opening that may affect the operation of the valve is to be noted. Photographic records of the valve condition are to be taken and included in the report.

3.5 Design series qualification

3.5.1 The qualification of quenching devices to prevent the passage of flame can be evaluated for other similar devices where one device has been tested and found satisfactory.

3.5.2 The quenching ability of a flame screen depends on the total mass of quenching lamellas/mesh. Provided the materials, thickness of materials, depth of lamellas/thickness of mesh layer and quenching gaps are the same, then

the same quenching ability can be qualified for different size of flame screen. This is subject to the following relations being satisfied.

$$\frac{n_1}{n_2} = \sqrt{\frac{S_1}{S_2}}$$

$$\frac{A_1}{A_2} = \frac{S_1}{S_2}$$

where:

n_1 = total depth of flame arrester corresponding to the number of lamellas of size 1 quenching device for a valve with a relief area equal to S_1

n_2 = total depth of flame arrester corresponding to the number of lamellas of size 2 quenching device for a valve with a relief area equal to S_2

A_1 = free area of quenching device for a valve with a relief area equal to S_1

A_2 = free area of quenching device for a valve with a relief area equal to S_2

3.5.3 The qualification of explosion relief valves of larger sizes than that which has been previously satisfactorily tested in accordance with [3.3] and [3.4] can be evaluated where valves are of identical type and have identical construction features, subject to the following items a) to c).

- a) The free area of a larger valve does not exceed three times + 5% that of the valve that has been satisfactorily tested.
- b) One valve of the largest size requiring qualification is subjected to satisfactory testing required by [3.2.3] and [3.3.2] b) except that a single valve will be accepted in [3.3.2] b)1) and the volume of the test vessel is not to be less than one third of the volume required by [2.1.13].
- c) The assessment and records are to be in accordance with [3.4], noting that [3.4.1] f) will only be applicable to Stage 2 for a single valve.

3.5.4 The qualification of explosion relief valves of smaller sizes than that which has been previously satisfactorily tested in accordance with [3.3] and [3.4] can be evaluated where valves are of identical type and have identical construction features, subject to the following items a) to c).

- a) The free area of a smaller valve is not less than one third of the valve that has been satisfactorily tested.
- b) One valve of each smaller size requiring qualification is subjected to satisfactory testing required by [3.2.3] and [3.3.2]b) except that a single valve will be accepted in [3.3.2]b)1) and the volume of the test vessel is not to be less than one third of the volume required by [2.1.13].
- c) The assessment and records are to be in accordance with [3.4], noting that [3.4.1]f) will only be applicable to Stage 2 for a single valve.

4 Report and approval

4.1 The test report

4.1.1 The test facility is to deliver a full report that includes the following information and documents:

- a) Test specification
- b) Details of test pressure vessel and valves tested
- c) The orientation in which the valve was tested (vertical or horizontal position)
- d) Methane in air concentration for each test
- e) Ignition source
- f) Pressure curves for each test
- g) Video recordings of each valve test
- h) The assessment and records stated in [3.4].

4.2 Approval

4.2.1 The approval of an explosion relief valve is at the discretion of the Society based on the appraisal plans and particulars and on the test facilities' report of the results of type testing.

APPENDIX 5

TYPE TEST PROCEDURE FOR CRANKCASE OIL MIST DETECTION AND ALARM EQUIPMENT

1 General

1.1 Application

1.1.1 This test procedure applies to type approved crankcase oil mist detection and alarm equipment as required under item Sec 2, [2.3.5].

1.1.2 This test procedure is also applicable to oil mist detection and alarm equipment intended for gear cases.

1.1.3 The provisions of Ch 3, Sec 6 apply as far as required in [3.1.1].

1.2 Purpose

1.2.1 The purpose of type test crankcase oil mist detection and alarm equipment is sevenfold:

- a) To verify the functionality of the system
- b) To verify the effectiveness of oil mist detectors
- c) To verify the accuracy of oil mist detectors
- d) To verify the alarm set points
- e) To verify time delays between oil mist leaving the source and alarm activation
- f) To verify the operation of alarms indicating functional failure in the equipment and associated arrangements
- g) To verify the influence of optical obscuration on detection.

2 Test houses

2.1 General

2.1.1 Test houses carrying out type testing of crankcase oil mist detection and alarm equipment are to satisfy the following criteria a) and b).

- a) A full range of facilities for carrying out the environmental and functionality tests required by this procedure are to be available and be acceptable to the Society.
- b) The test house that verifies the functionality of the equipment is to be equipped so that it can control, measure and record oil mist concentration levels in terms of mg/l to an accuracy of $\pm 10\%$ in accordance with this procedure.

3 Tests

3.1 Equipment testing

3.1.1 The range of tests is to include the following:

- a) For the alarm/monitoring panel:
 - 1) Functional tests described in [3.2]
 - 2) Electrical power supply failure test
 - 3) Power supply variation test
 - 4) Dry heat test
 - 5) Damp heat test
 - 6) Vibration test
 - 7) EMC test
 - 8) Insulation resistance test
 - 9) High voltage test
 - 10) Static and dynamic inclinations.
- b) For the detectors:
 - 1) Functional tests described in [3.2]
 - 2) Electrical power supply failure test
 - 3) Power supply variation test
 - 4) Dry heat test
 - 5) Damp heat test
 - 6) Vibration test
 - 7) Insulation resistance test
 - 8) High voltage test
 - 9) Static and dynamic inclinations.

3.2 Functional test process

3.2.1 All tests to verify the functionality of crankcase oil mist detection and alarm equipment are to be carried out in accordance with [3.2.2] to [3.2.6] with an oil mist concentration in air, known in terms of mg/l to an accuracy of $\pm 10\%$.

3.2.2 The concentration of oil mist in the test chamber is to be measured in the top and bottom of the chamber and these concentrations are not to differ by more than 10% (see also item [3.4.1]).

3.2.3 The oil mist monitoring arrangements are to be capable of detecting oil mist in air concentrations of between 0 and 10% of the lower explosive limit (LEL) or between 0 and a percentage corresponding to a level not less than twice the maximum oil mist concentration alarm set point.

Note 1: The LEL corresponds to an oil mist concentration of approximately 50mg/l (about 4,1% weight of oil in air mixture).

3.2.4 The alarm set point for oil mist concentration in air is to provide an alarm at a maximum level corresponding to not more than 5% of the LEL approximately 2,5 mg/l.

3.2.5 Where alarm set points can be altered, the means of adjustment and indication of set points are to be verified against the equipment Manufacturer's instructions.

3.2.6 Where oil mist is drawn into a detector/monitor via piping arrangements, the time delay between the sample leaving the crankcase and operation of the alarm is to be determined for the longest and shortest lengths of pipes recommended by the Manufacturer. The pipe arrangements are to be in accordance with the Manufacturer's instructions/recommendations.

3.2.7 Detector equipment that is in contact with the crankcase atmosphere and may be exposed to oil splash and spray from engine lubricating oil is to be demonstrated as being such that openings do not occlude or become blocked under continuous oil splash and spray conditions. Testing is to be in accordance with arrangements proposed by the Manufacturer and agreed by the Society.

3.2.8 Detector equipment may be exposed to water vapour from the crankcase atmosphere which may affect its sensitivity and it is to be demonstrated that exposure to such conditions will not affect the functional operation of the detector equipment. Where exposure to water vapour and/or water condensation has been identified as a possible source of equipment malfunctioning, testing is to demonstrate that any mitigating arrangements, such as heating, are effective. Testing is to be in accordance with arrangements proposed by the Manufacturer and agreed by the Society.

This testing is in addition to that required by [3.1.1] b) 5) and is concerned with the effects of condensation caused by the detection equipment being at a lower temperature than the crankcase atmosphere.

3.3 Detectors and alarm equipment to be tested

3.3.1 The detectors and alarm equipment selected for the type testing are to be selected from the Manufacturer's normal production line by the QSCS Classification Society (see Pt A, Ch 1, Sec 1, [1.2.1]) witnessing the tests.

3.3.2 Two detectors are to be tested. One is to be tested in clean condition and the other in a condition representing the maximum level of lens obscuration specified by the Manufacturer.

3.4 Method

3.4.1 The following requirements are to be satisfied at type test.

3.4.2 Oil mist generation is to satisfy the following items a) to e).

a) Oil mist is to be generated with suitable equipment using an SAE 80 monograde mineral oil or equivalent and supplied to a test chamber having a volume of not less than 1 m³. The oil mist produced is to have a maximum droplet size of 5 µm. The oil droplet size is to be checked using the sedimentation method.

b) The oil mist concentrations used are to be ascertained by the gravimetric deterministic method or equivalent.

For this test, the gravimetric deterministic method is a process where the difference in weight of a 0,8 µm pore size membrane filter is ascertained from weighing the filter before and after drawing 1 litre of oil mist through the filter from the oil mist test chamber. The oil mist chamber is to be fitted with a recirculating fan.

c) Samples of oil mist are to be taken at regular intervals and the results plotted against the oil mist detector output. The oil mist detector is to be located adjacent to where the oil mist samples are drawn off.

d) The results of a gravimetric analysis are considered invalid and are to be rejected if the resultant calibration curve has an increasing gradient with respect to the oil mist detection reading. This situation occurs when insufficient time has been allowed for the oil mist to become homogeneous. Single results that are more than 10% below the calibration curve are to be rejected. This situation occurs when the integrity of the filter unit has been compromised and not all of the oil is collected on the filter paper.

e) The filters are required to be weighed to a precision of 0,1 mg and the volume of air/oil mist is to be sampled to 10 ml.

3.4.3 The test is to be witnessed by authorised personnel from QSCS Classification Societies (see Pt A, Ch 1, Sec 1, [1.2.1]) where type testing approval is required by the Society.

3.4.4 Oil mist detection equipment is to be tested in the orientation (vertical, horizontal or inclined) in which it is intended to be installed on an engine or gear case as specified by the equipment Manufacturer.

3.4.5 Type testing is to be carried out for each type of oil mist detection and alarm equipment for which a Manufacturer seeks approval. Where sensitivity levels can be adjusted, testing is to be carried out at the extreme and mid-point level settings.

3.5 Assessment

3.5.1 Assessment of oil mist detection equipment is to address the following points:

a) The equipment to be tested is to have evidence of design appraisal/approval by the QSCS Classification Society witnessing the tests.

b) Details of the detection equipment to be tested are to be recorded such as name of the Manufacturer, type designation, oil mist concentration assessment capability and alarm settings.

c) After completion of the tests, the detection equipment is to be examined and the condition of all components ascertained and documented. Photographic records of the monitoring condition are to be taken and included in the report.

3.6 Design series qualification

3.6.1 The approval of one detection/monitoring device may be used to qualify other devices having identical construction details. Proposals are to be submitted for consideration by the Society.

4 Report and approval

4.1 Report

4.1.1 The test house is to provide a full report which includes the following information and documents:

- a) Test specification.
- b) Details of equipment tested.
- c) Results of tests.

4.2 Approval

4.2.1 Type approval of crankcase oil mist detection equipment is at the discretion of the Society based on the appraisal plans and particulars and on the test house report of the results of type testing.

4.2.2 The following information is to be submitted to the Society for acceptance of oil mist detection and alarm arrangements:

- a) Description of oil mist detection equipment and system including alarms.
- b) Copy of the test house report identified in [4.1].
- c) Schematic layout of engine oil mist detection arrangements showing location of detectors/sensors and piping arrangements and dimensions.
- d) Maintenance and test manual, which is to include the following information:
 - 1) intended use of equipment and its operation
 - 2) functionality tests to demonstrate that the equipment is operational and that any faults can be identified and corrective actions communicated
 - 3) maintenance routines and spare parts recommendations
 - 4) limit setting and instructions for safe limit levels
 - 5) where necessary, details of configurations in which the equipment is and is not to be used.