

Rules for the Classification of Workboats

Effective from 1 January 2025

GENERAL TERMS AND CONDITIONS
OF EMIRATES CLASSIFICATION SOCIETY – L.L.C – O.P.C (TASNEEF)
EFFECTIVE AS OF 1 APRIL 2025

DEFINITIONS

Administration	means the government of the state whose flag the Ship is entitled to fly or under whose authority the Ship is authorised to operate in the specific case.
Client	means the interested party and any other party who requires the Services.
Certificate of Classification	means a certificate of classification, issued by a Society and the certificate confirms that the vessel's structure, machinery, and equipment meet the society's specific technical rules and regulations.
Interested Party	means the party, other than the society, having an interest in or responsibility for the Ship, product, plant or system subject to classification or certification (such as the owner of the Ship and his representatives, the Ship builder, the engine builder or the supplier of parts to be tested) who requests the Services or on whose behalf the Services are requested.
Owner	means the registered owner, the Ship owner, the manager or any other party with the responsibility, legally or contractually, to keep the Ship seaworthy or in service, having particular regard to the provisions relating to the maintenance of class laid down in part a, chapter 2 of the rules for the classification of Ships or in the corresponding rules indicated in the specific rules.
Register of Ships	means a register book, also known as a Register of Ships, is a comprehensive record of vessels that are classified by a society.
Rules	means the documents below issued by the Society: <ul style="list-style-type: none"> a. Rules for the classification of Ships or other special units. b. Complementary rules containing the requirements for certification of products, plants, systems and other or containing the requirements for the assignment of additional class notations. c. Rules for the application of statutory rules, containing the rules to perform the duties delegated by administrations. d. Guides to carry out particular activities connected with Services. e. Any other technical document, as for example rule variations or interpretations.

GENERAL TERMS AND CONDITIONS
OF EMIRATES CLASSIFICATION SOCIETY – L.L.C – O.P.C (TASNEEF)
EFFECTIVE AS OF 1 APRIL 2025

DEFINITIONS

Administration	means the government of the state whose flag the Ship is entitled to fly or under whose authority the Ship is authorised to operate in the specific case.
Client	means the interested party and any other party who requires the Services.
Certificate of Classification	means a certificate of classification, issued by a Society and the certificate confirms that the vessel's structure, machinery, and equipment meet the society's specific technical rules and regulations.
Interested Party	means the party, other than the society, having an interest in or responsibility for the Ship, product, plant or system subject to classification or certification (such as the owner of the Ship and his representatives, the Ship builder, the engine builder or the supplier of parts to be tested) who requests the Services or on whose behalf the Services are requested.
Owner	means the registered owner, the Ship owner, the manager or any other party with the responsibility, legally or contractually, to keep the Ship seaworthy or in service, having particular regard to the provisions relating to the maintenance of class laid down in part a, chapter 2 of the rules for the classification of Ships or in the corresponding rules indicated in the specific rules.
Register of Ships	means a register book, also known as a Register of Ships, is a comprehensive record of vessels that are classified by a society.
Rules	means the documents below issued by the Society: <ul style="list-style-type: none"> a. Rules for the classification of Ships or other special units. b. Complementary rules containing the requirements for certification of products, plants, systems and other or containing the requirements for the assignment of additional class notations. c. Rules for the application of statutory rules, containing the rules to perform the duties delegated by administrations. d. Guides to carry out particular activities connected with Services. e. Any other technical document, as for example rule variations or interpretations.

Services	means the activities described in Article 1 below, rendered by the Society upon request made by or on behalf of the Interested Party.
Ship	means ships, boats, craft and other special units, as for example offshore structures, floating units and underwater craft.
Society	means Emirates Classification Society LLC OPC and/or its affiliated entities providing the Services.
Surveyor	means technical staff acting on behalf of the society in performing the Services.
UAE	means United Arab Emirates.

ARTICLE 1

- 1.1 The purpose of the Society is, among others, the classification and certification of Ships and the certification of their parts and components.
- 1.2 The Society (a) sets forth and develops Rules; (b) publishes the Register of Ships; and (c) issues certificates, statements and reports based on its survey activities.
- 1.3 The Society also takes part in the implementation of national and international rules and standards as delegated by various Governments.
- 1.4 The Society carries out technical assistance activities on request and provides special services outside the scope of classification, which is regulated by these general conditions unless expressly excluded in the particular contract.

ARTICLE 2

- 2.1 The Rules developed by the Society reflect the level of its technical knowledge at the time they are published. Therefore, the Society, though committed, also through its research and development services, to continuous updating, does not guarantee they meet state-of-the-art science and technology at the time of publication or that they meet the Society's or others' subsequent technical developments.
- 2.2 The Interested Party is required to know the Rules on the basis of which the Services are provided. With particular reference to Classification Services, special attention is to be given to the Rules concerning class suspension, withdrawal and reinstatement. In case of doubt or inaccuracy, the Interested Party is to promptly contact the Society for clarification. The Rules for Classification of Ships are published on the Society's website: www.tasneefmaritime.ae
- 2.3 The Society exercises due care and skill:
 - (a) in the selection of its Surveyors; and
 - (b) in the performance of its Services, taking into account the level of its technical knowledge at the time the

Services are performed.

- 2.4 Surveys conducted by the Society include, but are not limited to, visual inspection and non-destructive testing. Unless otherwise required, surveys are conducted through sampling techniques and do not consist of comprehensive verification or monitoring of each component of the Ship or of the items subject to certification. The surveys and checks made by the Society, either on board Ships or with remote techniques, do not necessarily require the constant and continuous presence of the Surveyor. The Society may also commission laboratory testing, underwater inspection and other checks to qualified service suppliers, who will carry out these duties under their responsibility. Survey practices and procedures are selected by the Society based on its experience and knowledge and according to generally accepted technical standards in the sector.

ARTICLE 3

- 3.1 The class assigned to a Ship, like the reports, statements, certificates or any other document or information issued by the Society, reflect the discretionary opinion of the Society concerning compliance, at the time the Service is provided, of the Ship or product subject to certification, with the applicable Rules (given the intended use and within the relevant time frame).
- 3.2 The Society is under no obligation to make statements or provide information about elements or facts which are not part of the specific scope of the Service requested by the Interested Party or on its behalf.
- 3.3 No report, statement, notation on a plan, review, Certificate of Classification, document or information issued or given as part of the Services provided by the Society shall have any legal effect or implication other than a representation that, on the basis of the checks made by the Society, the Ship, structure, materials, equipment, machinery or any other item covered by such document or information meet the Rules. Any such document is issued solely for the use of the Society, its committees and clients or other duly authorised bodies and for no other purpose. Therefore, the Society cannot be held liable for any act made or document issued by other parties on the basis of the statements or information given by the Society. The validity, application, meaning and interpretation of a Certificate of Classification, or any other document or information issued by the Society in connection with its Services, are governed by the Rules of the Society, whom is the sole subject entitled to make such authentic interpretation. Any disagreement on technical matters between the Interested Party and the Surveyor in the carrying out of his functions shall be raised in writing as soon as possible with the Society, which will settle any divergence of opinion or dispute.
- 3.4 The classification of a Ship, or the issuance of a certificate or other document connected with classification or certification and in general with the performance of Services by the Society shall have the validity conferred upon it by the Rules of the Society at the time of the assignment of class or issuance of the certificate; in no case shall it amount to a statement or warranty of seaworthiness, structural integrity, quality or fitness for a particular purpose or service of any Ship, structure, material, equipment or machinery inspected or tested by the Society.
- 3.5 Any document issued by the Society in relation to its activities reflects the condition of the Ship or the subject of certification or other activity at the time of the check.
- 3.6 The Rules, surveys and activities performed by the Society, reports, certificates and other documents issued by

the Society are in no way intended to replace the duties and responsibilities of other parties including, without limitation, Governments, designers, ship builders, manufacturers, repairers, suppliers, contractors or sub-contractors, Owners, operators, charterers, underwriters, sellers or intended buyers of a Ship or other product or system surveyed.

- 3.7 These documents and activities do not relieve such parties from any fulfilment, warranty, responsibility, duty or obligation (also of a contractual nature) expressed or implied or in any case incumbent on them, nor do they confer on such parties any right, claim or cause of action against the Society. With particular regard to the duties of the Owner, the Services undertaken by the Society do not relieve the Owner of his duty to ensure proper maintenance of the Ship and ensure seaworthiness at all times. Likewise, the Rules, surveys performed, reports, certificates and other documents issued by the Society are intended neither to guarantee the buyers of the Ship, its components or any other surveyed or certified item, nor to relieve the seller of the duties arising out of the law or the contract, regarding the quality, commercial value or characteristics of the item which is the subject of transaction.
- 3.8 In no case, therefore, shall the Society assume the obligations incumbent upon the above-mentioned parties, even when it is consulted in connection with matters not covered by its Rules or other documents.
- 3.9 In consideration of the above, and within the limits of liability under Article 5 below, the Interested Party undertakes to relieve and hold harmless the Society from any third party claim, as well as from any liability in relation to the latter concerning the Services rendered, where these are attributable to the Interested Party.
- 3.10 Insofar as they are not expressly provided for in these General Conditions, the duties and responsibilities of the Owner and Interested Parties with respect to the Services rendered by the Society are described in the Rules applicable to the specific Service rendered.

ARTICLE 4

- 4.1 Any request for the Society's Services shall be submitted in writing and signed by or on behalf of the Interested Party. Such a request will be considered irrevocable as soon as received by the Society and shall entail acceptance by the applicant of all relevant requirements of the Rules, including these General Conditions. Upon acceptance of the written request by the Society, a contract between the Society and the Interested Party is entered into, which is regulated by the present General Conditions.
- 4.2 In consideration of the Services rendered by the Society, the Interested Party and the person requesting the service shall be jointly liable for the payment of the relevant fees and costs, even if the service is not concluded for any cause not pertaining to the Society. In the latter case, the Society shall not be held liable for non-fulfilment or partial fulfilment of the Services requested. In the event of non-payment of the invoice within the contractually agreed terms, the Society reserves the right to request, in addition to the full payment of the principal amount due and without the need for further formal notice, also:
- (a) Late payment interest at a rate of 5% per annum, calculated from the due date of the invoice until full payment is received, in accordance with the applicable laws in the United Arab Emirates or the country from where the invoice is issued. Any applicable VAT, taxes, or statutory levies shall be borne by the Client as per the laws

of the respective jurisdiction;

- (b) full reimbursement of any costs incurred for debt recovery, including, but not limited to, legal fees, administrative expenses, and the costs of any extrajudicial actions; and
- (c) any additional amount due as compensation for damages suffered as a result of the delay or non-compliance, where documented.

- 4.3 The contract for the classification of a Ship or for other Services may be terminated and any certificates revoked at the request of one of the parties, subject to at least 30 days' notice to be given in writing. Failure to pay, even in part, the fees due for Services carried out by the Society will entitle the Society to immediately terminate the contract and suspend the Services.
- 4.4 The Society may withhold, suspend or withdraw any certificate, report or service in the event of non-payment of fees due to any member of the Society by the Client in relation to the entire business relationship between any member of the Society and the Client or by any other companies belonging to the same group as the Client. This also applies when the obligation to pay rests with a builder or with the Ship's previous Owner.
- 4.5 For every case of termination or suspension of the contract, the fees for the activities performed until the time of the termination or of the suspension shall be owed to the Society as well as the expenses incurred in view of activities already programmed; this is without prejudice to the right to compensation due to the Society as a consequence of the termination or of the suspension.
- 4.6 With particular reference to Ship classification and certification, unless decided otherwise by the Society, termination of the contract implies that the assignment of class to a Ship is withheld or, if already assigned, that it is suspended or withdrawn; any statutory certificates issued by the Society will be withdrawn in those cases where provided for by agreements between the Society and the flag State.

ARTICLE 5

- 5.1 In providing the Services, as well as other correlated information or advice, the Society, its Surveyors, servants or agents operate with due diligence for the proper execution of the activity. However, considering the nature of the activities performed (see Article 2), it is not possible to guarantee absolute accuracy, correctness and completeness of any information or advice supplied. Express and implied warranties are specifically disclaimed.
- 5.2 Therefore, subject to what provided for in Article 5.3 below, and also in the case of activities carried out by delegation of Governments, neither the Society nor any of its Surveyors will be liable for any loss, damage or expense of whatever nature sustained by any person, in tort or in contract, derived from carrying out the Services.
- 5.3 Notwithstanding the provisions in Article 5.1 above, should any user of the Society's Services prove that he has suffered a loss or damage due to any negligent act or omission of the Society, its Surveyors, servants or agents, then the Society will pay compensation to such person for his proved loss, up to, but not exceeding, five times the amount of the fees charged for the specific Services, information or opinions from which the loss or damage derives or, if no fee has been charged, a maximum of AED5,000 (Arab Emirates Dirhams Five Thousand only).
- 5.4 Where the fees charged are related to a number of Services, the amount of the fees will be apportioned for the purpose of the calculation of the maximum compensation, by reference to the estimated time involved in the

performance of the Service from which the damage or loss derives. Any liability for indirect or consequential loss, damage or expense is specifically excluded. In any case, irrespective of the amount of the fees charged, the maximum damages payable by the Society will not be more than AED 300,000 (Three Hundred Thousand Dirhams). Payment of compensation under this Article will not entail any admission of responsibility and/or liability by the Society and will be made without prejudice to the disclaimer clause contained in Article 5.

- 5.5 Any claim for loss or damage of whatever nature by virtue of the provisions set forth herein shall be made to the Society in writing, within the shorter of the following periods: THREE MONTHS from the date on which the Services were performed or THREE MONTHS from the date on which the damage was discovered. Failure to comply with the above deadline will constitute an absolute bar to the pursuit of such a claim against the Society.

ARTICLE 6

- 6.1 Any dispute, controversy, or claim arising out of or relating to these Rules, the Services of the Society, or the interpretation, breach, or termination thereof, shall first be referred to the parties' senior management for amicable resolution within thirty (30) days of written notice by either party.
- 6.2 If the dispute is not resolved amicably under Article 6.1, it shall be exclusively governed by and construed in accordance with the laws of the Emirate of Abu Dhabi and the applicable federal laws of the United Arab Emirates. The courts of Abu Dhabi shall have exclusive jurisdiction to settle any such dispute.

ARTICLE 7

- 7.1 All plans, specifications, documents and information provided by, issued by, or made known to the Society, in connection with the performance of its Services, will be treated as confidential and will not be made available to any other party other than the Owner without authorisation of the Interested Party, except as provided for or required by any applicable legislation from a competent authority. Information about the status and validity of class and statutory certificates, including transfers, changes, suspensions, withdrawals of class, conditions of class, operating conditions or restrictions issued against classed ships and other related information, as may be required, may be published on the website or released by other means, without the prior consent of the Interested Party.
- 7.2 Information about the status and validity of other certificates and statements may also be published on the website or released by other means, without the prior consent of the Interested Party.
- 7.3 Notwithstanding the general duty of confidentiality owed by the Society to its clients in Article 7.1 above, the Society's clients hereby accept that the Society will participate in the IACS Early Warning System which requires each Classification Society to provide other involved Classification Societies with relevant technical information on serious hull structural and engineering systems failures, as defined in the IACS Early Warning System (but not including any drawings relating to the Ship which may be the specific property of another party), to enable such useful information to be shared and used to facilitate the proper working of the IACS Early Warning System. The Society will provide its clients with written details of such information sent to the involved Classification Societies.
- 7.4 In the event of transfer of class, addition of a second class or withdrawal from a double/dual class, the Interested Party undertakes to provide or to permit the Society to provide the other Classification Society with all building plans and drawings, certificates, documents and information relevant to the classed unit, including its history file,

as the other Classification Society may require for the purpose of classification in compliance with the applicable legislation and relative IACS Procedure. It is the Owner's duty to ensure that, whenever required, the consent of the builder is obtained with regard to the provision of plans and drawings to the new Society, either by way of appropriate stipulation in the building contract or by other agreement.

- 7.5 In the event that the ownership of the Ship, product or system subject to certification is transferred to a new subject, the latter shall have the right to access all pertinent drawings, specifications, documents or information issued by the Society or which have come to the knowledge of the Society while carrying out its Services, even if related to a period prior to transfer of ownership.

ARTICLE 8

- 8.1 The Society shall not be obliged to perform any obligation towards the Client (including, without limitation, obligation to (a) perform, deliver, accept, sell, purchase, pay or receive money to, from or through a person or entity, or (b) engage in any other act) if this would be in violation of, inconsistent with or expose the Society to punitive measures under any United Nations resolutions and/or under any laws, regulations, decrees, ordinances, orders, demands, requests, rules or requirements of EU, United Kingdom, and/or United States of America and which relate to foreign trade controls, export controls, embargoes or international boycotts (applying, without limitation, to the financing, payment, insurance, transportation, delivery or storage of product and/or services) hereinafter referred to as "Trade Sanctions".
- 8.2 Recurring the above circumstances during the performance of the contract, the Society shall be entitled at its sole and absolute discretion:
- (a) to immediately suspend payment or performance of the Services which are the object of the contract until such;
 - (b) time as the Trading Sanctions are in force;
 - (c) to a full disengagement from the obligation affected by the Trading Sanctions, in the event that the inability to fulfill the said obligation persists until the term provided for the fulfilment hereunder, provided that where the relevant obligation relates to payments for activities and/or Services which have already been delivered, the affected payment obligation shall remain only suspended until such time as the Trading Sanctions no longer apply to the payment ; and/or
 - (d) to terminate the contract, without prejudice of the Society's rights pursuant to Article 4.

ARTICLE 9

Should any part of these General Conditions be declared invalid, this will not affect the validity of the remaining provisions.

ARTICLE 10

When the Society provides its Services to a consumer - i.e. a natural person who does not act within the scope of his business or professional activity - the following provisions do not apply Article 3 (as far as the Society is solely entitled to the authentic interpretation of the Rules); Article 4, (as far as the payment of the fees is also due for Services not

concluded due to causes not attributable to the Interested Party); Article 5 (as far as the exclusion of liability is concerned), and Article 6 (as far as the jurisdiction of a Board of Arbitrators based in Abu Dhabi is concerned).

ARTICLE 11

- 11.1 The Society and the Interested Party shall promote safety, protect human health and environment and create safe working conditions for their personnel.
- 11.2 The Interested Party shall guarantee that the working environment in which the Society's Surveyor will be required to work is adequate, safe and in all respect compliant with the applicable legislation and Rules and shall adopt all necessary measures to mitigate and/or control any relevant risk.
- 11.3 Furthermore, in accordance with the applicable legislation and Rules, the Interested Party shall provide the Society with complete and detailed information relevant to any actual or potential specific risk existing in the work areas where the Surveyor will be required to operate and relevant to the performance of the Services as well as with any specific safety measure that the Society's Surveyor is requested to comply with.
- 11.4 The Society reserves not to commence and/or to suspend the Services and/or to terminate the contract, claiming compensation for any damage occurred, if it considers that the safety requirements listed in this Article are not satisfactorily met.

EXPLANATORY NOTE

1. Reference edition

The reference edition of these Rules is the edition effective from 1 August 2020 issued with Rule Variation MESEC/2020/06 on 29/07/2020.

2. Effective date of the requirements

2.1 All requirements in which new or amended provisions with respect to those contained in the reference edition have been introduced are followed by a date shown in brackets.

The date shown in brackets is the effective date of entry into force of the requirements as amended by the last updating. The effective date of all those requirements not followed by any date shown in brackets is that of the reference edition.

2.2 Item 5 below provides a summary of the technical changes from the preceding edition. In general, this list does not include those items to which only editorial changes have been made not affecting the effective date of the requirements contained therein.

3. Rule Variations and Corrigenda

Until the next edition of the Rules is published, Rule Variations and/or corrigenda, as necessary, will be published on the Tasneef web site (www.Tasneef.ae). Except in particular cases, paper copies of Rule Variations or corrigenda are not issued.

4. Rule subdivision and cross-references

4.1 Rule subdivision

The Rules are subdivided into six parts, from A to C.

Part A: Classification and Surveys

Part B: Hull and Stability

Part C: Machinery, Systems and Fire Protection

Each Part consists of:

- Chapters
- Sections and possible Appendices
- Articles
- Sub-articles
- Requirements

Figures (abbr. Fig) and Tables (abbr. Tab) are numbered in ascending order within each Section or Appendix.

5.2 Cross-references

Examples: Pt A, Ch 1, Sec 1, [3.2.1] or Pt A, Ch 1, App 1, [3.2.1]

- Pt A means Part A

The part is indicated when it is different from the part in

which the cross-reference appears. Otherwise, it is not indicated.

- Ch 1 means Chapter 1

The Chapter is indicated when it is different from the chapter in which the cross-reference appears. Otherwise, it is not indicated.

- Sec 1 means Section 1 (or App 1 means Appendix 1)

The Section (or Appendix) is indicated when it is different from the Section (or Appendix) in which the cross-reference appears. Otherwise, it is not indicated.

- [3.2.1] refers to requirement 1, within sub-article 2 of article 3.

Cross-references to an entire Part or Chapter are not abbreviated as indicated in the following examples:

- Part A for a cross-reference to Part A
- Part A, Chapter 1 for a cross-reference to Chapter 1 of Part A.

5. Summary of amendments

Foreword

The date of entry into force of each new or amended item is shown in brackets after the number of the item concerned.

RULES FOR THE CLASSIFICATION OF WORKBOATS

Parts **A B C**

Part A **CLASSIFICATION AND SURVEYS**

Part B **HULL AND STABILITY**

Part C **MACHINERY, SYSTEMS AND FIRE PROTECTION**

RULES FOR THE CLASSIFICATION OF WORKBOATS

Part A Classification and Surveys

Chapters **1 2 3 4**

CHAPTER 1	FOREWORD
CHAPTER 2	SURVEYS OF VESSELS WITH REINFORCED PLASTIC HULL
CHAPTER 3	SURVEYS OF VESSELS WITH ALUMINIUM ALLOY HULL
CHAPTER 4	SURVEYS OF SHIPS WITH HIGH DENSITY POLYETHYLENE (HDPE) HULL

CHAPTER 1

FOREWORD

Section 1 Field of Application of the Rules, Service Notation and General

1	Field of application of the Rules	9
	1.1	
2	Service Notation	9
	2.1	
3	Navigation and design category	9
	3.1 Navigation Notations	
	3.2 Design categories	
4	General	10
	4.1 Compliance with statutory rules and regulations	
	4.2 Abbreviations	
	4.3 Technical documentation	

CHAPTER 2

SURVEYS OF VESSELS WITH REINFORCED PLASTIC HULL

Section 1 Field of application and surveys

1	Field of application	13
1.1		
2	Periodical surveys and relevant frequency, anticipations and postponements	13
2.1	Surveys in general	
3	First Classification Surveys	13
3.1	First Classification Surveys of vessels built under Tasneef supervision	
3.2	First Classification Surveys of vessels built without Tasneef supervision	
4	Periodical hull surveys	13
4.1	Annual surveys	
4.2	Class renewal survey (hull) and bottom survey in dry condition	

CHAPTER 3

SURVEYS OF VESSELS WITH ALUMINIUM ALLOY HULL

Section 1 Field of application and surveys

1	Field of application	17
1.1		
2	Periodical surveys and relevant frequency, anticipations and postponements	17
2.1	Surveys in general	
3	First Classification Surveys	17
3.1	First Classification Surveys of vessels built without Tasneef supervision	

CHAPTER 4

SURVEYS OF SHIPS WITH HIGH DENSITY POLYETHYLENE (HDPE) HULL

Section 1 Field of Application and Surveys

1	Field of application	21
1.1		
2	Periodical surveys and relevant frequency, anticipations and postponements	21
2.1	Surveys in general	
3	First Classification Surveys	21
3.1	First Classification Surveys of ships built under Tasneef supervision	
3.2	First Classification Surveys of ships built without Tasneef supervision	
4	Periodical hull surveys	21
4.1	Annual surveys	
4.2	Class renewal survey (hull) and bottom survey in dry condition	

Part A
Classification and Surveys

Chapter 1
FOREWORD

SECTION 1 FIELD OF APPLICATION OF THE RULES AND GENERAL

SECTION 1

FIELD OF APPLICATION OF THE RULES, SERVICE NOTATION AND GENERAL

1 Field of application of the Rules

1.1

1.1.1 (1/5/2023)

These Rules apply for the purpose of classification of vessels with steel, reinforced plastic, aluminium alloy or high density polyethylene (HDPE) hull - including catamarans and rigid inflatable boats (RIBs) - in commercial use, other than those in use for recreational, sport and pleasure, having a load line length between 4 m and 24 m, with a maximum speed of 45 knots and carrying no more than 12 passengers.

The application of these Rules to vessels with reinforced plastic hull or aluminium alloy hull having different load line length or speed may be considered by the Society on a case-by-case basis, depending on their specific operation and construction characteristics.

These rules deal with HDPE ships having slender hull shapes, having a length not greater than 24 m and having an operating profile extended up to "moderate environment"; HDPE ships having different features will be specially considered on a case by case basis.

Where necessary, in the various parts of these Rules, specific conditions relevant to the field of application of the requirements are given.

The requirements for assignment of special service notations will be established by Tasneef case by case on the basis of the requirements of Part E of the Rules for the Classification of Ships.

For the purpose of the assignment of special class notations, the requirements of Part F of the Rules for the Classification of Ships are to be complied with, as far as practicable, at Tasneef's discretion, in relation to the navigation and service notations, vessel size and hull material.

2 Service Notation

2.1

2.1.1 (1/1/2025)

The vessels complying with the classification requirements of these Rules are assigned with the service notation **WORKBOAT**, that may be completed by the following additional service features:

- **Aquaculture:** when the workboat is designed to reach the sea fish breeding site, provide assistance to the

breeding facilities, catch the fish living group and take it back to the onshore aquaculture center.

- **Crew Transfer Vessel - CTV:** when the workboat is designed to transport technician and other personnel out to sites.
- **Dive Support Vessel - DSV:** when the workboat is designed to support the offshore diving operation.
- **MULTICAT:** when the workboat is designed as multi-purpose workboat for offshore works and transport. Normally a multicat is equipped with one or more winches and cranes as well as a spacious flat deck.
- **Patrol and Guard Vessel:** when the workboat is designed to patrol a coastal area or site for security, observation and defense.
- **Pilot boats:** when the workboat is designed to transport maritime pilots from harbors to ships that need piloting, or vice versa.
- **Seismic and Geotechnical Survey Vessel - SGSV:** when the workboat is designed for the purpose of research, seismic survey and mapping at seas.
- **Small Tug:** when the workboat has a navigation notation not broader than NAV 60, a design category not higher than "C" and is provided with towing devices for towage activities featured by a towing pull not greater than 49,05 KN.
- **Taxi:** when the workboat is designed to transport paying passengers on rivers, canals, or sea coastal area.
- **Windfarm Service Vessel - WSV:** when the workboat is designed to transport technician and other personnel to offshore wind farm and to support operations of wind farm maintenance and survey.

3 Navigation and design category

3.1 Navigation Notations

3.1.1 (1/7/2021)

Every classed workboat is to be assigned one navigation notation.

3.1.2 (1/7/2021)

The navigation notation **unrestricted navigation** is assigned to a ship intended to operate in any area and any period of the year.

3.1.3 (1/7/2021)

The navigation notation "**NAV 150**" is assigned to ships intended to operate only within 150 nautical miles from a safe haven.

3.1.4 (1/7/2021)

The navigation notation "NAV 60" is assigned to ships intended to operate only within 60 nautical miles from a safe haven.

3.1.5 (1/7/2021)

The navigation notation "NAV 30" is assigned to ships intended to operate only within 30 nautical miles from a safe haven.

3.1.6 (1/7/2021)

The navigation notation "NAV 3" is assigned to ships intended to operate only within 3 nautical miles from a safe haven.

3.1.7 (1/7/2021)

The assignment of a navigation notation does not absolve the Interested Party from compliance with any international and national regulations established by the Administrations for a ship operating in national waters, or a specific area, or a navigation zone. Neither does it waive the requirements in Pt A, Ch 1, Sec 1, [3.3.1] of Rules for Classification of ship.

3.2 Design categories

3.2.1 (1/7/2021)

Every classed workboat is to be assigned one design category as described in Pt B, Ch 2, Sec 2, Tab 2.

3.2.2 (1/7/2021)

The operation of the vessel is limited to the sea and weather condition of the relevant design category.

3.2.3 (1/7/2021)

Every classed workboat is to be designed according to a minimum design category against the navigation notation as per Tab 1.

Table 1 (1/7/2021)

Navigation notation	design category			
	A	B	C	D
UNRESTRICTED	X	-	-	-
NAV 150	X	-	-	-
NAV 60	X	X	-	-
NAV 30	X	X	X	-
NAV 3	X	X	X	X

This design category is indicated after the navigation notation.

Example: **unrestricted navigation - "A"**

Example: **NAV30 - "C"**

The service of the workboat is limited to the navigation notation and design category as applicable.

4 General

4.1 Compliance with statutory rules and regulations

4.1.1 With regard to what is not expressly stated or modified in these Rules, for the purpose of classification, the requirements of the Rules for the Classification of Ships, as far as applicable, are to be complied with.

The classification of a vessel, and more in general, TASNEEF's decisions and acts, do not absolve the Interested Party from compliance with any additional and/or more stringent rules and requirements, issued by the Administration of the state whose flag the vessel is entitled to fly, and/or of the State of the base port from which the vessel operates, and with any other specific provisions issued to this end.

4.2 Abbreviations

4.2.1 Rules

In these Rules, the wording "Rules" is intended to mean the effective Tasneef "Rules for the Classification of Ships"; i. e., when in the text, reference is made to Part A of the Rules, reference is to be made to Part A of the Rules for the Classification of Ships.

4.3 Technical documentation

4.3.1

Technical Documentation is to enable understanding of the design and construction of the vessel and is to confirm compliance with the requirements given in these Rules.

Requirements for documentation are found in the beginning of each section.

Part A
Classification and Surveys

Chapter 2

**SURVEYS OF VESSELS WITH REINFORCED
PLASTIC HULL**

SECTION 1 FIELD OF APPLICATION AND SURVEYS

SECTION 1

FIELD OF APPLICATION AND SURVEYS

1 Field of application

1.1

1.1.1 The requirements of this Chapter apply to vessels with reinforced plastic hull.

For the purpose of classification and surveys, the requirements of Part A of the Rules are to be complied with, taking account of the modifications and additions specified in [2], [3] and [4], as far as the frequency and the technical requirements relevant to surveys are concerned.

2 Periodical surveys and relevant frequency, anticipations and postponements

2.1 Surveys in general

2.1.1 For all periodical surveys, the requirements of Part A, Chapter 2, Section 2 of the Rules are to be fulfilled. However, in the case of vessels more than 15 years old, the frequency of the Bottom survey is subject to special consideration.

3 First Classification Surveys

3.1 First Classification Surveys of vessels built under Tasneef supervision

3.1.1 Special inspections are required at the following stages:

- a) when the hull lamination starts with the application of gel-coat;
- b) before starting the arrangement of internal stiffeners;
- c) when the hull is extracted from the mould;
- d) when the connection of the hull to the deck starts;
- e) before the installation of the dolly, if any;
- f) when the core of sandwich structure is arranged.

In addition, during the supervision of the first hull, an inspection of the shipyard is performed in order to verify that it is provided with adequate equipment in relation to the materials used and to the type of manufacture and that the quality of the laminates is ensured.

3.2 First Classification Surveys of vessels built without Tasneef supervision

3.2.1 The eligibility for class is evaluated on the basis of the substantial compliance with the applicable Tasneef Rules, with the examination of main drawings and documents and following the outcome of a First Classification Survey specifically carried out with an extension adequate to the individual cases.

Where appropriate, within reasonable limits, a proven service record of satisfactory performance may be used as criterion of equivalence. Special consideration will be given to vessels of recent construction.

For the purpose of classification, it may be required that adequate data for the evaluation of materials, machinery and arrangements in general are made available; such adequate data may consist of the details of specific rules and requirements originally applied but, where appropriate, tests and checks, to be established in the individual cases, may also be required.

4 Periodical hull surveys

4.1 Annual surveys

4.1.1 In the case of hulls made of sandwich type structures, it is to be carefully checked that the parts are not detached from the core. The check is to be performed by hammering the shell and evaluating the differences in the sound heard or by means of checks with non-destructive methods recognized by Tasneef.

4.1.2 The connection between hull and deck is to be carefully checked, in particular when hull and deck are made of different materials.

4.2 Class renewal survey (hull) and bottom survey in dry condition

4.2.1 In addition to the requirements for the Annual surveys given in [4.1], the presence of "osmosis" phenomena in the laminates of the underwater body and/or of cracks in the gel-coat is to be verified.

To this end, the vessel is to be made available for the bottom survey in dry condition before the application of any paint, so as to allow a careful visual inspection.

Part A
Classification and Surveys

Chapter 3

**SURVEYS OF VESSELS WITH ALUMINIUM
ALLOY HULL**

SECTION 1 FIELD OF APPLICATION AND SURVEYS

SECTION 1

FIELD OF APPLICATION AND SURVEYS

1 Field of application

1.1

1.1.1 The requirements of this Chapter apply to vessels with aluminium alloy hull.

The applicable requirements of Part A of the Rules are generally to be complied with, taking account of the modifications and additions specified in [2] and [3], as far as the frequency and the technical requirements relevant to surveys are concerned.

2 Periodical surveys and relevant frequency, anticipations and postponements

2.1 Surveys in general

2.1.1 For all periodical surveys, the requirements of Part A, Chapter 2, Section 2 of the Rules are to be fulfilled. However, in the case of vessels more than 15 years old, the frequency of the Bottom survey is subject to special consideration.

3 First Classification Surveys

3.1 First Classification Surveys of vessels built without Tasneef supervision

3.1.1 The eligibility for class is evaluated on the basis of the substantial compliance with the applicable Tasneef Rules, with the examination of main drawings and documents and following the outcome of a First Classification Survey specifically carried out with an extension adequate to the individual cases.

Where appropriate, within reasonable limits, a proven service record of satisfactory performance may be used as criterion of equivalence. Special consideration will be given to vessels of recent construction.

For the purpose of classification, it may be required that adequate data for the evaluation of materials, machinery and arrangements in general are made available; such adequate data may consist of the details of specific rules and requirements originally applied but, where appropriate, tests and checks, to be established in the individual cases, may also be required.

Part A
Classification and Surveys

Chapter 4

**SURVEYS OF SHIPS WITH HIGH DENSITY
POLYETHYLENE (HDPE) HULL**

SECTION 1 FIELD OF APPLICATION AND SURVEYS

SECTION 1 FIELD OF APPLICATION AND SURVEYS

1 Field of application

1.1

1.1.1 (1/5/2023)

The requirements of this Chapter apply to ships with high density polyethylene (HDPE) hull.

For the purpose of classification and surveys, the requirements of Part A of the Rules are to be complied with, taking account of the modifications and additions specified in [2], [3] and [4], as far as the frequency and the technical requirements relevant to surveys are concerned.

2 Periodical surveys and relevant frequency, anticipations and postponements

2.1 Surveys in general

2.1.1 (1/5/2023)

For all periodical surveys, the requirements of Part A, Chapter 2, Section 2 of the Rules are to be fulfilled. However, in the case of ships more than 15 years old, the frequency of the Bottom survey is subject to special consideration.

3 First Classification Surveys

3.1 First Classification Surveys of ships built under Tasneef supervision

3.1.1 (1/5/2023)

The eligibility for class is evaluated on the basis of the substantial compliance with the applicable Tasneef Rules, with the examination of main drawings and documents and following the outcome of a First Classification Survey specifically carried out with an extension adequate to the individual cases.

Before the supervision of the first construction, an inspection of the shipyard is performed in order to verify that it is provided with adequate equipment in relation to the materials used and to the type of manufacture.

In addition, storage premises of the HDPE sheets, welding consumables shall be so equipped and arranged that the

material supplier's directions for storage and handling are followed.

3.2 First Classification Surveys of ships built without Tasneef supervision

3.2.1 (1/5/2023)

The eligibility for class is evaluated on the basis of the substantial compliance with the applicable Tasneef Rules, with the examination of main drawings and documents and following the outcome of a First Classification Survey specifically carried out with an extension adequate to the individual cases. Where appropriate, within reasonable limits, a proven service record of satisfactory performance may be used as a criterion of equivalence. Special consideration will be given to ships of recent construction. For the purpose of classification, it may be required that adequate data for the evaluation of materials, machinery and arrangements in general are made available; such adequate data may consist of the details of specific rules and requirements originally applied but, where appropriate, tests and checks, to be established in the individual cases, may also be required.

4 Periodical hull surveys

4.1 Annual surveys

4.1.1 (1/5/2023)

Visual inspection to be performed on the areas exposed to weather, sun light for surface cracking, particular attention is to be given to welded connections.

4.2 Class renewal survey (hull) and bottom survey in dry condition

4.2.1 (1/5/2023)

In addition to the requirements for the Annual surveys given in [4.1], all external surface is to check due to the cracks. To this end, the ship is to be made available for the bottom survey in dry condition before the application of any coating, so as to allow a careful visual inspection.

RULES FOR THE CLASSIFICATION OF WORKBOATS

Part B Hull and Stability

Chapters **1 2 3 4 5**

CHAPTER 1	HULL GENERAL
CHAPTER 2	GLASS REINFORCED PLASTIC HULL
CHAPTER 3	ALLUMINIUM HULL
CHAPTER 4	STABILITY
CHAPTER 5	HIGH DENSITY POLYETHYLENE HULLS

CHAPTER 1

HULL GENERAL

Section 1 Design Principles

1	Design principles	37
	1.1 Applications	
	1.2 Documentation	
2	Arrangement Of Bulkheads	39
	2.1	
3	Accommodation	39
	3.1	
4	Steering Position	40
	4.1	
5	Safety of Personnel	40
	5.1	

Section 2 Hull Outfitting

1	Propeller shaft brackets	41
	1.1 General	
	1.2 Shaft brackets	
	1.3 Plated bossing	
2	Waterjets	41
	2.1	
3	Towing Equipment	42
	3.1 General	
	3.2 Equipment	
	3.3 Hull Foundations	

Section 3 Rudders

1	Rudders	44
	1.1 General	
	1.2 Gross scantlings	
	1.3 Arrangements	
	1.4 Materials	
	1.5 Welding and design details	
2	Force and torque acting on the rudder	46
	2.1 Rudder blade without cut-outs	
3	Loads acting on the rudder structure	47
	3.1 General	

4	Rudder stock scantlings	48
	4.1 Bending moment	
	4.2 Scantlings	
5	Rudder stock couplings	48
	5.1 Horizontal flange couplings	
	5.2 Couplings between rudder stocks and tillers	
	5.3 Cone couplings between rudder stocks and rudder blades with key	
	5.4 Cone couplings between rudder stocks and rudder blades with special arrangements for mounting and dismounting the couplings	
	5.5 Vertical flange couplings	
	5.6 Couplings by continuous rudder stock welded to the rudder blade	
	5.7 Skeg connected with rudder trunk	
6	Rudder stock bearings	51
	6.1 General	
7	Rudder blade scantlings	52
	7.1 General	
	7.2 Strength checks	
	7.3 Rudder blade plating	
	7.4 Connections of rudder blade structure with solid parts in forged or cast steel	
	7.5 Connection of the rudder blade with the rudder stock by means of horizontal flanges	
	7.6 Single plate rudders	
8	Rudder trunk	54
	8.1 Materials, welding and connection to the hull	
9	Simplex rudder shaft	54
	9.1 General	
10	Steering nozzles	54
	10.1 General	
11	Azimuth propulsion system	55
	11.1 General	

Section 4 Equipment

1	Equipment Number	56
	1.1	
2	Anchors	56
	2.1	
3	Chain cables and ropes	56
	3.1	
4	Windlass	56
	4.1	

Section 5 Non-Structural Fuel Tanks

1	General	58
	1.1	
2	Metallic tanks	58
	2.1 General	
	2.2 Scantlings	
3	Non-metallic tanks	58
	3.1 General	
	3.2 Scantlings	
4	Tests on tanks	59
	4.1 General	
	4.2 Leak testing	

Section 6 Testing

1	Application	60
	1.1	

Appendix 1 Buoyancy Materials

1	Requirements	61
	1.1	

Appendix 2 Rib Collars

1	General	62
	1.1	

CHAPTER 2

GLASS REINFORCED PLASTIC HULL

Section 1 Material and Construction

1	Structures	65
	1.1	
2	Materials	70
	2.1 Terminology	
	2.2 Materials making up the laminates	
	2.3 Core materials for sandwich laminates	
	2.4 Type approval of materials	
	2.5 Laminates with glass fibre reinforcements and associated characteristics	
	2.6 Laminates with reinforcement in fibres other than glass and associated characteristics	
	2.7 Other materials	
	2.8 Testing of hull laminates	
3	Hull construction processes and shipyards or workshops	72
	3.1 General	
	3.2 Moulds	
	3.3 Laminating	
	3.4 Hardening and release of laminates	
	3.5 Defects in the laminates	
	3.6 Shipyards or workshops	

Section 2 Design Loads and Hull Scantling

1	Application	74
	1.1	
2	Design acceleration	74
	2.1 Vertical acceleration at LCG	
	2.2 Longitudinal distribution of vertical acceleration	
	2.3 Transverse acceleration	
	2.4 Assessment of limit operating conditions	
3	Overall loads	76
	3.1 Twin-hull vessel transverse loads	
	3.2 Small waterplane area twin-hull (SWATH) vessel-Forces	
4	Local loads	77
	4.1 Introduction	
	4.2 Loads	
	4.3 Impact pressure on the bottom	
	4.4 Impact pressure on bottom of cross-deck and internal sides (for twin-hull vessel)	
	4.5 Sea pressures	
	4.6 Sea pressures on front walls of the hull	
	4.7 Sea pressures on deckhouses	
	4.8 Deck loads	
	4.9 Pressures on tank structures	
	4.10 Pressures on subdivision bulkheads	

5	Direct calculations	80
	5.1 General	
6	Scantlings	80
	6.1 Introduction	
	6.2 Definitions	
	6.3 Structural scantlings - General	
	6.4 Bottom structure	
	6.5 Side shell structure	
	6.6 Deck structure	
	6.7 Bulkhead structures	
	6.8 Superstructure and deckhouse structures	
	6.9 Principles of building	
7	General requirements for structural scantlings	91
	7.1 Terminology	
	7.2 Size and distribution of hull structural scantlings, type of structure and structural continuity	
	7.3 Longitudinal strength	
	7.4 Direct calculations	
	7.5 Coefficients for the scantlings of structures relative to the mechanical properties of laminates	
	7.6 Mass of reinforcement fibres in laminates	
	7.7 Coefficients for scantlings and type of structure of high speed hulls	
	7.8 Structures with sandwich construction	
8	Keel; stem and sternpost or sternframe (transom); rudder horn; propeller shaft brackets	93
	8.1 Keel	
	8.2 Stem and sternpost or sternframe (transom)	
	8.3 Rudder horn	
	8.4 Propeller shaft brackets	
9	Bottom, side and deck plating	94
	9.1 General	
	9.2 Bottom plating	
	9.3 Side and sheerstrake plating	
	9.4 Local thickness increases in external plating	
	9.5 Deck plating	
10	Bottom, side and deck structures	95
	10.1 Single bottom structures	
	10.2 Double bottom structures	
	10.3 Side hull structures	
	10.4 Deck structures	
11	Aft and fore end hull structures	97
	11.1 Strengthening of the bottom forward	
	11.2 Side supports aft of the fore peak	
	11.3 Forward deck structures	
	11.4 Fore peak	
12	Hull subdivision bulkheads and tanks for liquids	97
	12.1 Hull subdivision bulkheads	
	12.2 Tanks for liquids	
	12.3 Structural fuel tanks	
	12.4 Tests	
	12.5 Other bulkheads	

-
- 13.1 General
 - 13.2 Structural scantlings
 - 13.3 Bulwarks

CHAPTER 3

ALLUMINIUM HULL

Section 1 Materials, Connections and Structure Design Principles

1	Materials and connections	103
1.1	General requirements	
1.2	Aluminium alloy hull structures	
1.3	Extruded plating	
1.4	Tolerances	
1.5	Influence of welding on mechanical characteristics	
1.6	Material factor K for scantlings of structural members made of aluminium alloy	
1.7	Fillet welding	
1.8	Riveted connections for aluminium alloy hulls	
1.9	Welded connections	
1.10	Corrosion protection - Heterogeneous steel/aluminium alloy assembly	
2	Structure design principles	107
2.1	Protection against corrosion	
2.2	Rounding-off	

Section 2 Design Loads and Hull Scantlings

1	Design loads	108
1.1	Application	
2	Hull scantlings	108
2.1		
2.2	Definitions and symbols	
2.3	Minimum thicknesses	
2.4	Overall strength	
2.5	Buckling strength of aluminium alloy structural members	
2.6	Plating	
2.7	Ordinary stiffeners	
2.8	Primary supporting members	
2.9	Pillars made of aluminium alloys	
2.10	Tank bulkheads	
2.11	Subdivision bulkheads	
2.12	Non-tight bulkheads	
2.13	Independent prismatic tanks	

CHAPTER 4

STABILITY

Section 1 General Requirements

1	Documentation to be submitted and general requirements	127
	1.1 Documentation to be submitted	
	1.2 General Requirements	
2	Freeboard	128
	2.1 Decked vessel	
	2.2 Open vessel	
3	Stability Requirements	128
	3.1 Decked vessel	
	3.2 Open vessel	
	3.3 Open vessel with buoyancy	
	3.4 Stability of Small Tugs	
4	Freeing ports and recesses	129
	4.1 Freeing ports	
	4.2 Drainage	
5	Weathertight integrity	129
	5.1	

CHAPTER 5

HIGH DENSITY POLYETHYLENE HULLS

Section 1 Design Principles and Stability

1	Application	133
	1.1	

Section 2 Materials, Connections and Structure Design Principles

1	Materials and connections	134
	1.1 General requirements	
	1.2 HDPE hull structures	
2	Structure design principles	135
	2.1 Protection against high temperature	
	2.2 Rounding-off	

Section 3 Design Loads and Hull Scantling

1	Application	136
	1.1	
2	Hull scantlings	136
	2.1 Introduction	
3	Check for overall loads	137
	3.1 Transverse section strength characteristics	
	3.2 Yielding checks for overall loads	
	3.3 Buckling checks for overall loads	
	3.4 Overall stiffness check	

Section 4 Hull Outfitting

1	Application	139
	1.1	

Section 5 Rudders, Equipment and Testing

1	Rudders	140
	1.1 Application	
2	Equipment	140
	2.1 Application	
3	Testing	140
	3.1 Application	

Part B
Hull and Stability

CHAPTER 1
HULL GENERAL

SECTION 1	DESIGN PRINCIPLES
SECTION 2	HULL OUTFITTING
SECTION 3	RUDDERS
SECTION 4	EQUIPMENT
SECTION 5	NON STRUCTURAL FUEL TANKS
SECTION 6	TESTING
APPENDIX 1	BUOYANCY MATERIALS
APPENDIX 2	TESTING

SECTION 1

DESIGN PRINCIPLES

1 Design principles

1.1 Applications

1.1.1 (1/5/2023)

For reinforced plastic vessels, the requirements of Ch 1 and Ch 2 apply.

For aluminium alloy hull vessels, the requirements of Ch 1 and Ch 3 apply.

For steel hull displacement vessels, the requirements in Pt B, Ch 8 of the Rules for the Classification of Ships apply. However, for steel hull displacement vessels having operative characteristics corresponding to the construction feature "light ship" (i.e. restricted navigation, length not greater than 50 m and speed greater than 15 knots), the requirements in Ch 3 of the Rules for the Classification of High Speed Craft may be applied instead of those in Pt B, Ch 8 of the Rules for the Classification of Ships.

For steel hull planing vessels, the requirements in Ch 3 of the Rules for the Classification of High Speed Craft apply.

Craft with $V \geq 10 L^{0.5}$ will be individually considered by Tasneef that, in general, may accept scantling according to ISO 12215-5 with safety factor increased of 25%.

1.1.2 Direct calculations

Tasneef may require direct calculations to be carried out, if deemed necessary.

Such calculations are to be carried out based on structural modelling, loading and checking criteria accepted by Tasneef.

1.1.3 Units

Unless otherwise specified, the following units are used in the Rules:

- thickness of plating, in mm,
- section modulus of stiffeners, in cm^3 ,
- shear area of stiffeners, in cm^2 ,
- span and spacing of stiffeners, in m,
- stresses, in N/mm^2 ,
- concentrated loads, in kN,
- distributed loads, in kN/m or kN/m^2 .

1.1.4 Definitions and symbols

The definitions of the following terms and symbols are applicable throughout this Chapter and its Appendices and are not, as a rule, repeated in the different paragraphs. Definitions applicable only to certain paragraphs are specified therein.

"Moulded base line": The line parallel to the summer load waterline, crossing the upper side of keel plate or the top of skeg at the middle of length L .

"Hull": The hull is the outer boundary of the enclosed spaces of the vessel, except for the deckhouses, as defined below.

"Chine": For hulls that do not have a clearly identified chine, the chine is the hull point at which the tangent to the hull is inclined 50° to the horizontal.

"Bottom": The bottom is the part of the hull between the keel and the chines.

"Main deck": The main deck is the uppermost complete deck of the hull. It may be stepped.

"Side": The side is the part of the hull between the chine and the main deck.

"Castle": A castle is a superstructure extending from side to side of the vessel or with the side plating not being inboard of the shell plating more than 4% of the local breadth. In general, such a superstructure fitted on the weather deck of the vessel is considered as "constituting a step of the strength deck" when it extends within $0,4 L$ amidships for at least $0,15 L$. Other castles are considered as "not constituting a step of the strength deck".

"Deckhouse": The deckhouse is a decked structure located above the main deck, with lateral walls inboard of the side of more than 4 per cent of the local breadth. Structure located on the main deck and whose walls are not in the same longitudinal plane as the under side shell may be regarded as a deckhouse.

"Cross-deck": For twin-hull vessel, the cross-deck is the structure connecting the two hulls.

"Fore end": Hull region forward of $0,9 L$ from the aft perpendicular.

"Deadrise angle α_d ": For hulls that do not have a clearly identified deadrise angle, α_d is the angle between the horizontal and a straight line joining the keel and the chine. For catamarans with non-symmetrical hulls (where inner and outer deadrise angles are different), α_d is the lesser angle.

"Aft end": Hull region abaft of $0,1 L$ from the aft perpendicular.

"Midship area": Hull region between $0,3 L$ and $0,7 L$ from the aft perpendicular.

L : Rule length, in m, equal to L_{WL} where L_{WL} is the waterline measured with the vessel at rest in calm water.

FP : forward perpendicular, i.e. the perpendicular at the intersection of the waterline at draught T and the foreside of the stem

AP : aft perpendicular, i.e. the perpendicular located at a distance L abaft of the forward perpendicular

B : the greatest moulded breadth, in m, of the vessel

B_w : the greatest moulded breadth, in m, measured on the waterline at draught **T**; for catamarans, **B_w** is the breadth of each hull

D : depth, in m, measured vertically in the transverse section at the middle of length **L** from the moulded base line of the hull(s) to the top of the deck beam at one side of the main deck (if the main deck is stepped, **D** will be defined in each separate case at the discretion of Tasneef)

T : draught of the vessel, in m, measured vertically on the transverse section at the middle of length **L**, from the moulded base line of the hull(s) to the full load waterline, with the vessel at rest in calm water and, for SESs, in the off-cushion condition

Δ: moulded displacement at draught **T**, in sea water (mass density = 1,025 t/m³), in tonnes

C_B : total block coefficient, defined as follows:

$$C_B = \frac{\Delta}{(1,025 \cdot L \cdot B_w \cdot T)}$$

For catamarans, **C_B** is to be calculated for a single hull, assuming **D** equal to one half of the vessel's displacement

V : maximum service speed, in knots

g : acceleration of gravity, equal to 9,81 m/s²

LCG : longitudinal centre of gravity of the vessel.

1.2 Documentation

1.2.1

The documentation to be submitted to the Society is to be in accordance with the requirements in Tab 1 and Tab 2.

Additional documentation which may be required are listed in the appropriate sections.

Additional documentation may be required by the Tasneef for appraisal according to Flag State requirements.

Table 1 : Documentation to be submitted for approval, as applicable

No.	Item
1	Midship section including: <ul style="list-style-type: none"> main particulars (L_{wl}, B_{wl}, D, L) and maximum speed V materials and associated mechanical properties
2	Profile and decks
3	Plan of the decks including: <ul style="list-style-type: none"> openings loads acting, if different from Rule loads
4	Longitudinal and transverse section
5	Longitudinal and transversal stiffening members
6	Shell expansion and framing including openings
7	Watertight bulkheads, deep tanks and transom including: <ul style="list-style-type: none"> openings and their closing appliances location of overflow
8	Structure of stern/side doors their closing appliances
9	Tank structure
10	Engine room structures including foundation for heavy machinery components
11	Aft peak structures
12	Forepeak structures
13	Superstructures and deckhouses including openings with sill heights and their closing appliances
14	Support structure for crane including the design loads and connections to the hull structures
15	Hatchways, hatch covers and ports including securing and tightening appliances
16	Propeller shaft struts including material and dimensions
17	Propeller shaft brackets with their attachments to the hull
18	Appendages with their attachments to the hull

No.	Item
19	Rudder and rudder stock including: <ul style="list-style-type: none"> • details of bearings and seals • materials of all components • calculation speed
20	Arrangement and particulars of anchoring and mooring equipment.

Table 2 : Documentation to be submitted for information, as applicable

No.	Item
1	General arrangement
2	Tank arrangements
3	Capacity plan
4	Body plan
5	Arrangement of cathodic protection.

2 Arrangement Of Bulkheads

2.1

2.1.1

Vessels have to be fitted with watertight bulkheads extended up to the deck:

- 1 watertight bulkhead if $L < 6$ m
- 2 watertight bulkheads if $6 < L < 15$ m
- 3 watertight bulkheads (one should be the collision bulkhead) if $L > 15$ m; in this case vessels are to be provided with a collision bulkhead located between $0.05L_{wl}$ and $0.1L_{wl}$ aft from F_p .

The engine room on vessels of more than 15m are to be enclosed within watertight divisions and the top of the space to be above the design waterline.

Doors and hatches in watertight bulkheads are to be reduced to the minimum and to be watertight. Small openings for penetrating pipes and electrical cables are to be watertight and located in the central higher part of the bulkhead.

3 Accommodation

3.1

3.1.1

Accommodation areas have to be arranged so that they are not dangerous for the users (i.e. not having shar corners, flammable materials, close to high temperature surfaces, vessels under pressure, or moving mechanical parts).

Control and items to be operated in emergency have to be located in accommodation area.

3.1.2

Enclosed accommodation spaces are to have dedicated ventilation in accordance with an international standard.

Heating, cooking and spaces containing flammable liquids are to be vented independently from other spaces. All compartments are to be provided at least with natural ventilation.

Ventilation Inlets and outlets are to be far from engine exhaust.

3.1.3

Vessels are to be arranged with basic sanitary facilities (toilet and wash basin) with suitable ventilation as required by the Administration. This requirement may be waived for vessel for limited operation/area.

3.1.4

An ergonomic seat with the following minimum size have to be provided for every person onboard:

- width 500 mm
- depth 750 mm, free space for legs measured from persons back
- height 900 mm, from seat to free height of head.

The shapes of the seats are to be not dangerous (no sharp corner or fragile material).

Different dimensions if in accordance with the Administration may be accepted.

The strength of a seat is to be in accordance with an international standard accepted by Tasneef and the accelerations of the vessel. A minimum static load of 1 kN at the top of the backrest and a vertical load at the center of the seat equal to 2 kN are to be considered for the scantling.

Different scantling criteria if in accordance with the Administration may be accepted.

For vessel with speed exceeding 15 knots, the seats on open decks are to be minimum 380 mm lower than top of bulwark/railing unless they are provided with means for protecting persons from falling overboard when seated (such as seat belts).

In vessel with speed exceeding 45 knots all the seats are to be equipped with seat belts.

4 Steering Position

4.1

4.1.1

The design and layout of the steering position is to be suitable for the intended use and not used for other purposes.

The headroom in a wheelhouse is to be minimum 2m.

Every personnel is to have a seat in the steering position.

The steering position is to be equipped with the instrument and the equipment required by the Administration

4.1.2

For the field of vision from the steering position reference has to be done to EN ISO 11591. The requirements of the Administration may be used as an alternative.

5 Safety of Personnel

5.1

5.1.1

All areas above and below deck intended accessible to persons is to be equipped with either railings, bulwark, hand-holds of substantial design or other means of safe grip. External decks is normally be surrounded by railing or bulwark with the following characteristics:

- minimum 750 mm height
- distance between vertical stanchions not more than 1.5m.
- vertical distance between bars in rails normally is not to exceed 230 mm from deck level and 330 mm elsewhere
- the top rail is to have ergonomic shape.

Part of the railing may be dismantable.

5.1.2

All the areas where person has access are to be provided with non-skid surface and decks are to have a toe-rail of minimum 25 mm height at the outboard edge or gunwale.

5.1.3

For vessels with length L exceeding 6 m, or vessel with freeboard F exceeding 500 mm, an outboard rescue ladder or steps is to be fitted. The arrangement is to be suitable for a person in the water to enter the vessel. The lower step, or any suitable safe part of hull structure to step on, is to be arranged minimum 500 mm below waterline in light condition of the vessel. A foldable ladder, or other equivalent system, may be accepted when a safe release system is arranged for access from a position in the water.

5.1.4

For vessels required to be fitted with buoyancy elements, arrangement is to be fitted to enable persons in the water to hold on to the vessel in capsized condition.

5.1.5

Winches, cranes and other deck-gear are to be arranged to facility safe working.

Winches with open lines, lifting platforms and all types of movable deck gear, is to be shielded and provided with an automatic emergency stop activated by a single person.

Winch barrel, and similar gears are to have protection against line end etc. hitting the person operating the winch or gear.

Operation instructions are to be provided where the gear may be operated.

SECTION 2

HULL OUTFITTING

1 Propeller shaft brackets

1.1 General

1.1.1 For certain vessels, the propeller shafting is extended to the propeller bearings clear of the main hull.

Propeller shafting is either enclosed in bossing or independent of the main hull and supported by shaft brackets.

1.2 Shaft brackets

1.2.1 The scantlings of bracket arms are to be calculated as indicated below.

Bracket arms are to be attached to deep floors or girders of increased thickness, and the shell plating is to be increased in thickness and suitably stiffened, at the discretion of Tasneef. The thickness of the palm connecting the arms to the hull, if any, is to be not less than $0,2 \cdot d_s$, where:

d_s : Rule diameter, in mm, of the propeller shaft, calculated with the actual mechanical characteristics.

The arm is to be connected to the hull by means of through bolts, fitted with nut and lock nut, in way of the internal hull structures suitably stiffened at the discretion of Tasneef.

The arms of V-shaft brackets are to be perpendicular, as far as practicable.

The bearing length of the shaft bracket boss, in mm, is to be not less than $3 \cdot d_s$.

The thickness, in mm, of the shaft bracket boss after boring operation is to be not less than:

$$t_b = 0,2 \cdot d_s \cdot K_1$$

where:

$$K_1 : R_{ms}/R_{mb},$$

R_{ms} : minimum tensile strength, in N/mm², of the propeller shaft,

R_{mb} : minimum tensile strength, in N/mm², of the shaft bracket boss, with appropriate metallurgical temper.

Each arm of V-shaft brackets is to have a cross-sectional area, in mm², of not less than:

$$S = 87,5 \cdot 10^{-3} \cdot d_{so}^2 \cdot \left(\frac{1600 + R_{ma}}{R_{ma}} \right)$$

where:

d_{so} : Rule diameter, in mm, of the propeller shaft, for carbon steel material,

R_{ma} : minimum tensile strength, in N/mm², of arms, with appropriate metallurgical temper.

Single-arm shaft brackets are to have a section modulus at vessel plating level, in cm³, of not less than:

$$W = \frac{30}{R_{ma}} \cdot 10^{-3} \cdot l \cdot d_{so}^2 \cdot (n \cdot d_{so})^{0,5}$$

where:

l : length of the arm, in m, measured from the shell plating to the centreline of the shaft boss,

n : shaft revolutions per minute.

Moreover, the cross-sectional area of the arm at the boss is not to be less than 60% of the cross-sectional area at shell plating.

1.3 Plated bossing

1.3.1 Where the propeller shafting is enclosed within a plated bossing, the aft end of the bossing is to be adequately supported.

The scantlings of end supports are to be individually considered. Supports are to be designed to transmit loads to the main structure.

End supports are to be connected to at least two deep floors of increased thickness, or connected to each other within the vessel.

Stiffening of the boss plating is to be individually considered. At the aft end, transverse diaphragms are to be fitted at every frame and connected to floors of increased scantlings. At the fore end, web frames spaced not more than four frames apart are to be fitted.

2 Waterjets

2.1

2.1.1 The supporting structures of waterjets are to be able to withstand the loads thereby generated in the following conditions:

- maximum ahead thrust;
- maximum thrust at maximum lateral inclination;
- maximum reversed thrust (going astern).

Information on the above loads is to be given by the waterjet Manufacturer, supported by documents.

The shell thickness in way of nozzles, as well as the shell thickness of the tunnel, is to be individually considered. In general, such thicknesses are to be not less than 1,5 times the thickness of the adjacent bottom plating.

3 Towing Equipment

3.1 General

3.1.1 Application (1/1/2025)

The requirements reported in [3.2] to [3.3] apply to the towing equipment of Small Tugs and to the strength of the relevant hull foundations.

3.2 Equipment

3.2.1 Hooks and Winches (1/1/2025)

In general, towing hooks and winches are to be arranged in way of the ship's centerline, in such a position as to minimize heeling moments in normal working conditions.

The strength of the towing hooks and winches is to be verified in compliance with Pt E, Ch 14, Sec 2, [3.8.5] or [3.8.7] of the Rules, as applicable. Alternatively, marine certified towing hooks and winches are to be used.

3.2.2 Additional Equipment (1/1/2025)

Small Tugs are to be fitted with the additional equipment specified in Tab 1.

3.3 Hull Foundations

3.3.1 Strength of Steel Hull Foundations (1/1/2025)

The scantlings of the structures supporting the towing devices are to be such that, under a calculation load equal to 1,5·TP, the following conditions are fulfilled for all types of verifications (analytic or f.e.):

- General: $\sigma_{VM} \leq R_y / \gamma_R \gamma_m$ where $\gamma_R=1,02$, $\gamma_m=1,02$
- Compressed parts: $|\sigma| \leq \sigma_C / \gamma_R \gamma_m$ where $\gamma_R=1,05$, $\gamma_m=1,05$ and σ_C is the critical buckling stress to be obtained from Pt B, Ch 8, Sec 3 or from Pt B, Ch 8, Sec 4 or from Pt B, Ch 8, Sec 5 of the Rules, as the case may be.

3.3.2 Strength of Aluminium Hull Foundations (1/1/2025)

The scantlings of the structures supporting the towing devices are to be such that, under a calculation load equal to 1,5·TP, the following conditions are fulfilled for all types of verifications (analytic or f.e.):

- General: $\sigma_{VM} \leq 75 / K$ where K is the material factor defined in Ch 3, Sec 1, [1.6.1]
- Compressed parts: $|\sigma| \leq \sigma_C$ where σ_C is the critical buckling stress to defined in Ch 3, Sec 2, [2.5.3] or in Ch 3, Sec 2, [2.5.4], as the case may be.

3.3.3 Strength of GRP Hull Foundations (1/1/2025)

The scantlings of the structures supporting the towing devices are to be such that, under a calculation load equal to 1,5·TP, the following conditions are fulfilled for all types of verifications (analytic or f.e.):

- Single skin laminate, tensioned: $\sigma \leq R_m / 1,9$ where R_m is the ultimate tensile strength defined in Ch 2, Sec 1, Tab 3
- Single skin laminate, compressed: $\sigma \leq R_{mc} / 1,9$ where R_{mc} is the ultimate tensile strength defined in Ch 2, Sec 1, Tab 3
- Single skin laminate, sheared: $\tau \leq R_{mt} / 1,9$ where R_{mt} is the ultimate shear strength defined in Ch 2, Sec 1, Tab 3
- Sandwich laminate, tensioned skin: $\sigma \leq R_m / 1,9$ where R_m is the ultimate tensile strength defined in Ch 2, Sec 1, Tab 3
- Sandwich laminate, compressed skin: $\sigma \leq R_{mc} / 1,9$ or $0,32(E_c E_{cc} G_c)^{1/2}$ (whichever is the less) where R_{mc} is the ultimate compressive strength defined in Ch 2, Sec 1, Tab 3, E_c is the compressive modulus of inner skin defined in Ch 2, Sec 1, Tab 3, E_{cc} is the elastic modulus of the core (in MPa) and G_c is the elastic modulus of the core (in MPa).

Table 1 (1/1/2025)

Arrangement or equipment	Navigation Notation		
	Nav 60	Nav 30	Nav 3
Fender	Requested	Not Requested	Not Requested
Towing hook or winch	Requested	Requested	Requested
Towing Staple (1)	Requested	Requested	Not Requested
No. of towlines of suitable diameter (2)	1	1	0
Length, in m, of towlines of suitable diameter (2)	100	60	0
Line throwing appliances	Not Requested	Not Requested	Not Requested
Crew accommodation spaces	Not Requested	Not Requested	Not Requested
(1) The Society may not require the tow bar depending on the characteristics of the ship under consideration and where any obstructions on the deck area aft do not interfere with the towline during towing operations.			
(2) The suitability of the towline diameter is left to the judgement of the interested parties.			

3.3.4 Strength of HDPE Hull Foundations (1/1/2025)

The scantlings of the structures supporting the towing devices are to be such that, under a calculation load equal to 1,5·TP, the following conditions are fulfilled for all types of verifications (analytic or f.e.):

- a) General: $\sigma_{VM} \leq R_{eh} / 1,33$ where R_{eh} is the tensile stress at yield (MPa) of the HDPE defined by the manufacturer or given in Ch 5, Sec 2, Tab 1 (subject to the subsequent confirmation by mechanical tests).

SECTION 3 RUDDERS

Symbols

V_{AV} : maximum ahead service speed, in knots, with the vessel on summer load waterline; if V_{AV} is less than 10 knots, the maximum service speed is to be taken not less than the value obtained from the following formula:

$$V_{MIN} = \frac{V_{AV} + 20}{3}$$

V_{AD} : maximum astern speed, in knots, to be taken not less than $0,5 V_{AV}$

A : total area of the rudder blade, in m^2 , bounded by the blade external contour, including the mainpiece and the part forward of the centre-line of the rudder pintles, if any

k_1 : material factor, defined in [1.4.4]

k : material factor as defined below, as a function of the minimum guaranteed yield stress R_{eH} in N/mm^2 . For intermediate values of R_{eH} , k may be obtained by linear interpolation. Steels with a yield stress lower than $235 N/mm^2$ or greater than $390 N/mm^2$ are considered by the Society on a case by case basis:

- $k = 1$ for $R_{eH} = 235 N/mm^2$
- $k = 0,78$ for $R_{eH} = 315 N/mm^2$
- $k = 0,72$ for $R_{eH} = 355 N/mm^2$
- $k = 0,70$ for $R_{eH} = 390 N/mm^2$

C_R : rudder force, in N, acting on the rudder blade, defined in [2.1.2]

M_{TR} : rudder torque, in N.m, acting on the rudder blade, defined in [2.1.3]

M_B : bending moment, in N.m, in the rudder stock, defined in [3.1.6].

1 Rudders

1.1 General

1.1.1 In this section are reported the requirements for spade rudders. For other type of rudder reference is to be

made to the Rules Pt.B, Ch. 10, Sec.1 and Pt B, Ch 10, App 1.

These requirements apply to ordinary profile rudders without any special arrangement for increasing the rudder force, such as fins or flaps, steering propellers, etc. Unconventional rudders of unusual type or shape and those with speeds exceeding 45 knots will be the subject of special consideration by Tasneef.

In such cases, the scantlings of the rudder and the rudder stock will be determined by means of direct calculations to be agreed with Tasneef as regards the loads and schematisation.

1.1.2 Rudder with stock and blade made of composite material

Rudder stock made of composite material will be considered on a case by case basis taking into account the shear strength of the composite material.

The rudder blade may be built in composite provided that what above is satisfied. Such rudders are to have, in particular:

- stock and mainpiece, in solid or tubular bar, made of hull steel or light alloy, and mainpiece arms, of the same material, structurally connected to the mainpiece;
- blade made of a single plate or composed of two pre-formed plates, made of composite material, complying with the requirements of Ch 2 and filled with light material;
- in case of the glass reinforced plastic the mass per unit surface, m , in kg/m^2 , of the glass reinforcement of the material, $m = 0,6Vb$, where V is the maximum speed in knots and b is the width, in metres, of the rudder, if the latter has a rectangular contour; for rudders with non-rectangular contours, $b = A/h$ is to be taken, where h is the rudder height, in m, in way of the centre-line of pintles. The thickness of the plate is, in any case, to be not less than 5 mm. In case of carbon fiber or composite other than glass reinforced plastic direct calculations have to be sent. The admissible values of strength have to be taken from Tab 1 for keel and bottom plating; the values in column "1" are to be used for the load condition in still water, while those in column "2" apply to dynamic loads.

Table 1

Member	Allowable stresses	
	1	2
Keel, bottom plating	0,4 σ	0,8 σ
<p>Note 1: σ(N/mm²): the ultimate bending strength for single-skin laminates; the lesser of the ultimate tensile strength and the ultimate compressive strength for sandwich type laminates. In this case the shear stress in the core is to be no greater than 0,5 R_t where R_t is the ultimate shear strength of the core material; σ_t(N/mm²): the ultimate tensile strength of the laminate.</p>		

1.1.3 Ordinary profile spade rudders

The requirements of this Section apply to ordinary profile spade rudders made of steel, without any special arrangement for increasing the rudder force, whose maximum orientation at maximum vessel speed is limited to 35° on each side.

In general, an orientation greater than 35° is accepted for manoeuvres or navigation at very low speed.

1.1.4 High lift profiles

The requirements of this Section also apply to rudders made of steel fitted with flaps to increase rudder efficiency. For these rudder types, an orientation at maximum speed less than 35° may be accepted. In these cases, the rudder forces are to be calculated by the Designer for the most severe combinations between orientation angle and vessel speed. These calculations are to be considered by the Society on a case-by-case basis.

The rudder scantlings are to be designed so as to be able to sustain possible failures of the orientation control system, or, alternatively, redundancy of the system itself may be required.

1.1.5 Steering nozzles

The requirements for steering nozzles are given in [10].

1.1.6 Special rudder types

Rudders others than those mentioned above will be considered by the Society on a case-by- case basis.

1.2 Gross scantlings

1.2.1

All scantlings and dimensions referred to in this Section are gross, i.e. they include the margins for corrosion.

1.3 Arrangements

1.3.1

Effective means are to be provided for supporting the weight of the rudder without excessive bearing pressure, e.g. by means of a rudder carrier attached to the upper part of the rudder stock. The hull structure in way of the rudder carrier is to be suitably strengthened.

1.3.2

Suitable arrangements are to be provided to prevent the rudder from lifting.

In addition, structural rudder stops of suitable strength are to be provided, except where the steering gear is provided with its own rudder stopping devices.

1.3.3

In rudder trunks which are open to the sea, a seal or stuffing box is to be fitted above the deepest load waterline, to prevent water from entering the steering gear compartment and the lubricant from being washed away from the rudder carrier. If the top of the rudder trunk is below the deepest waterline two separate stuffing boxes are to be provided.

1.4 Materials

1.4.1

Rudders made of materials others than steel will be considered by the Society on a case-by-case basis.

1.4.2

Rudder stocks, pintles, coupling bolts, keys and cast parts of rudders are to be made of rolled steel, steel forgings or steel castings according to the applicable requirements in Part D, Ch 2 of the Rules.

1.4.3

The material used for rudder stocks, pintles, keys and bolts is to have a minimum yield stress not less than 200 N/mm².

1.4.4

The requirements relevant to the determination of scantlings contained in this Section apply to steels having a minimum yield stress equal to 235 N/mm².

Where the material used for rudder stocks, pintles, coupling bolts, keys and cast parts of rudders has a yield stress different from 235 N/mm², the scantlings calculated with the formulae contained in the requirements of this Section are to be modified, as indicated, depending on the material factor k_1 , to be obtained from the following formula:

$$k_1 = \left(\frac{235}{R_{eH}} \right)^n$$

where:

R_{eH} : yield stress, in N/mm², of the steel used, and not exceeding the lower of 0,7 R_m and 450 N/mm²,

R_m : minimum ultimate tensile strength, in N/mm², of the steel used,

n : coefficient to be taken equal to:

- $n = 0,75$ for $R_{eH} > 235$ N/mm²,
- $n = 1,00$ for $R_{eH} \leq 235$ N/mm².

1.4.5

Significant reductions in rudder stock diameter due to the application of steels with yield stresses greater than 235 N/mm² may be accepted by the Society subject to the results of a check calculation of the rudder stock deformations.

Large rudder stock deformations are to be avoided in order to avoid excessive edge pressures in way of bearings.

1.4.6

Welded parts of rudders are to be made of approved rolled hull materials.

1.5 Welding and design details

1.5.1

Slot-welding is to be limited as far as possible. Slot welding is not to be used in areas with large in-plane stresses transversely to the slots.

When slot welding is applied, the length of slots is to be minimum 75 mm with breadth of 2 t, where t is the rudder plate thickness, in mm. The distance between ends of slots is not to be more than 125 mm. The slots are to be fillet welded around the edges and filled with a suitable compound, e.g. epoxy putty. Slots are not to be filled with weld.

Continuous slot welds are to be used in lieu of slot welds. When continuous slot welding is applied, the root gap is to be between 6-10 mm. The bevel angle is to be at least 15°.

1.5.2

Welds between plates and heavy pieces (solid parts in forged or cast steel or very thick plating) are to be made as full penetration welds. In way of highly stressed areas e.g. upper part of spade rudder, cast or welding on ribs is to be arranged. Two sided full penetration welding is normally to be arranged. Where back welding is impossible welding is to be performed against ceramic backing bars or equivalent. Steel backing bars may be used and are to be continuously welded on one side to the heavy piece.

1.5.3

Requirements for welding and design details when the rudder stock is connected to the rudder by horizontal flange coupling are described in [5.1.1].

1.5.4

Requirements for welded connections of blade plating to vertical and horizontal webs are given in [7.3.6].

1.5.5

Requirements for welding and design details of rudder trunks are described in [8.1].

2 Force and torque acting on the rudder

2.1 Rudder blade without cut-outs

2.1.1 Rudder blade description

A rudder blade without cut-outs may have trapezoidal or rectangular contour.

2.1.2 Rudder force

The rudder force C_R is to be obtained, in N, from the following formula:

$$C_R = 132 n_t A V^2 r_1 r_2 r_3$$

where:

n_t : vessel's type coefficient, to be taken equal to 0,25,

V : V_{AV} , or V_{AD} , depending on the condition under consideration (for high lift profiles see [1.1.4]),

r_1 : shape factor, to be taken equal to:

$$r_1 = \frac{\lambda + 2}{3}$$

λ : coefficient, to be taken equal to:

$$\lambda = \frac{h^2}{A_T}$$

and not greater than 2,

A_T : area, in m^2 , to be calculated by adding the rudder blade area A to the area of the rudder post or rudder horn, if any, up to the height h,

h : mean height, in m, of the rudder area to be taken equal to (see Fig 1):



$$h = \frac{z_3 + z_4 - z_2}{2}$$

r_2 : coefficient to be obtained from Tab 2,

r_3 : coefficient to be taken equal to:

- $r_3 = 0,8$ for rudders outside the propeller jet (centre rudders on twin screw vessels, or similar cases),
- $r_3 = 1,15$ for rudders behind a fixed propeller nozzle,
- $r_3 = 1,0$ in other cases.

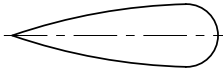
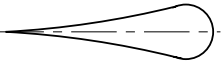
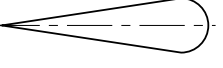
Table 2 : Values of coefficient r_2

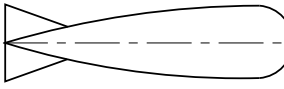
Rudder profile type	r_2 for ahead condition	r_2 for astern condition
NACA 00 - Goettingen 	1,10	0,80
Hollow 	1,35	0,90
Flat side 	1,10	0,90
High lift 	1,70	To be specially considered; if not known: 1,30
Fish tail 	1,40	0,80

Rudder profile type	r_2 for ahead condition	r_2 for astern condition
Single plate 	1,00	1,00
Mixed profiles (e.g. HSVA)	1,21	0,90

Figure 1 : Geometry of rudder blade without cut-outs



2.1.3 Rudder torque

The rudder torque M_{TR} , for both ahead and astern conditions, is to be obtained, in N.m, from the following formula:

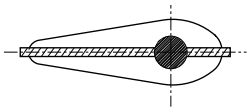
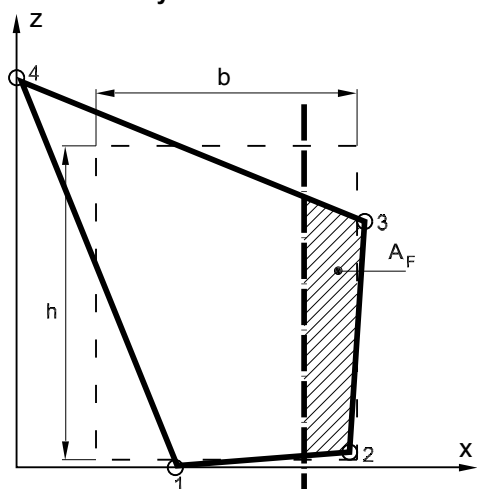
$$M_{TR} = C_R r$$

where:

r : lever of the force C_R , in m, equal to:

$$r = b \left(\alpha - \frac{A_F}{A} \right)$$

and to be taken not less than 0,1 b for the ahead condition,

b : mean breadth, in m, of rudder area to be taken equal to (see Fig 1):

$$b = \frac{x_2 + x_3 - x_1}{2}$$

α : coefficient to be taken equal to:

- $\alpha = 0,33$ for ahead condition,
- $\alpha = 0,66$ for astern condition,

A_F : area, in m^2 , of the rudder blade portion afore the centreline of rudder stock (see Fig 1).

3 Loads acting on the rudder structure

3.1 General

3.1.1 Loads

The force and torque acting on the rudder, defined in [2], induce in the rudder structure the following loads:

- bending moment and torque in the rudder stock,
- support forces,
- bending moment, shear force and torque in the rudder body.

3.1.2 Direct load calculations

The bending moment in the rudder stock, the support forces, and the bending moment and shear force in the rudder body and the loads in the rudder horn are to be determined through direct calculations to be performed in accordance to the static schemes and the load conditions specified in [3.1.3].

The other loads (i.e. the torque in the rudder stock and in the rudder body and the loads in the solepieces) are to be calculated as indicated in the relevant requirements of this Section.

3.1.3 Criteria for direct calculation of the loads acting on the rudder structure

These requirements provide the criteria for calculating the following loads:

- bending moment M_B in the rudder stock,
- support forces F_A ,
- bending moment M_R and shear force Q_R in the rudder body.

3.1.4 Load calculation

The loads in 3.1.3 are to be calculated through direct calculations depending on the type of rudder.

They are to be used for the stress analysis required in:

- [4], for the rudder stock,
- [7] for the rudder blade
- [8] for the rudder trunk.

3.1.5 Forces per unit length

The force per unit length p_R (see Fig 2) acting on the rudder body is to be obtained in N/m, from the following formula::

$$p_R = \frac{C_R}{\ell_{10}}$$

3.1.6 Moments and forces

The loads in [3.1.3] may therefore be obtained from the following formulae (See Fig 2):

- maximum bending moment M_B in the rudder stock, in N.m:

$$M_B = C_R \left(\ell_{20} + \frac{\ell_{10}(2C_1 + C_2)}{3(C_1 + C_2)} \right)$$

where C_1 and C_2 are the lengths, in m, defined in Fig 1,

- support forces, in N:

$$F_{A3} = \frac{M_B}{\ell_{30}}$$

$$F_{A1} = C_R + F_{A3}$$

- maximum shear force in the rudder body, in N:

$$Q_R = C_R$$

4 Rudder stock scantlings

4.1 Bending moment

4.1.1 General

The bending moment M_B in the rudder stock for spade rudders is to be determined according to [3.1.2] through a direct calculation.

4.2 Scantlings

4.2.1 Rudder stock subjected to combined torque and bending

For rudder stocks subjected to combined torque and bending, it is to be checked that the equivalent stress σ_E induced by the bending moment M_B and the torque M_{TR} is in compliance with the following formula:

$$\sigma_E \leq \sigma_{E,ALL}$$

where:

σ_E : equivalent stress to be obtained, in N/mm², from the following formula:

$$\sigma_E = \sqrt{\sigma_B^2 + 3\tau_T^2}$$

σ_B : bending stress to be obtained, in N/mm², from the following formula:

$$\sigma_B = 10^3 \frac{10,2 M_B}{d_{TF}^3}$$

τ_T : torsional stress to be obtained, in N/mm², from the following formula:

$$\tau_T = 10^3 \frac{5,1 M_{TR}}{d_{TF}^3}$$

$\sigma_{E,ALL}$: allowable equivalent stress, in N/mm², equal to:

$$\sigma_{E,ALL} = 118/k_1 \text{ N/mm}^2$$

For this purpose, the rudder stock diameter is to be not less than the value obtained, in mm, from the following formula:

$$d_{TF} = 4,2 (M_{TR} k_1)^{1/3} \left(1 + \frac{4}{3} \left(\frac{M_B}{M_{TR}} \right)^2 \right)^{1/6}$$

In general, the diameter of a rudder stock subjected to torque and bending may be gradually tapered above the upper stock bearing so as to reach the value of d_T in way of the quadrant or tiller, where d_T is the rudder stock diameter subject to torque only calculated as below:

$$d_T = 4,2 (M_{TR} k_1)^{1/3}$$

Figure 2 : Spade rudders

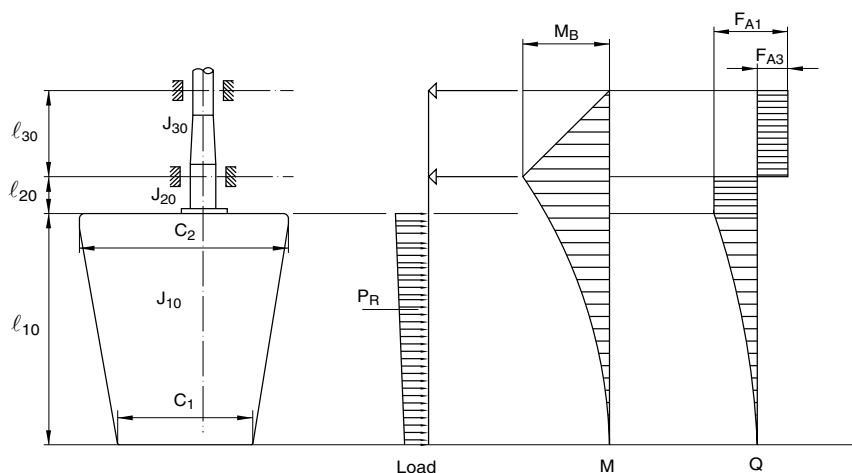

5 Rudder stock couplings

5.1 Horizontal flange couplings

5.1.1 General

In general, the coupling flange and the rudder stock are to be forged from a solid piece. A shoulder radius as large as practicable is to be provided for between the rudder stock and the coupling flange. This radius is to be not less than $0,13 d_{TF}$ or 45 mm, whichever is the greater.

The coupling flange may be welded onto the stock provided that its thickness is increased by 10%, and that the weld extends through the full thickness of the coupling flange and that the assembly obtained is subjected to heat treat-

ment. This heat treatment is not required if the diameter of the rudder stock is less than 75 mm.

Where the coupling flange is welded, the grade of the steel used is to be of weldable quality, particularly with a carbon content not greater than 0,25% and the welding conditions (preparation before welding, choice of electrodes, pre and post heating, inspection after welding) are to be defined to the satisfaction of the Society. The welded joint between the rudder stock and the flange is to be made in accordance with Fig 5. The throat weld at the top of the flange is to be concave shaped to give a fillet shoulder radius as large as practicable. This radius is to be not less than 45 mm (see Fig 3).

Figure 3 : Welded joints between rudder stock and coupling flange

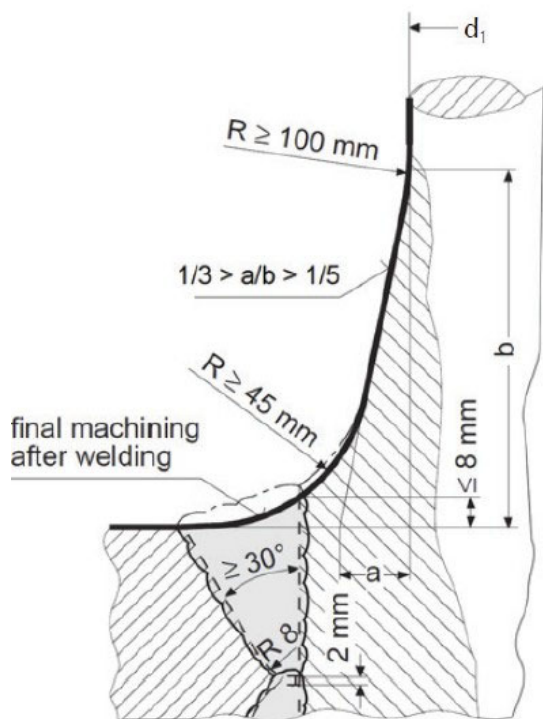

5.1.2 Bolts

Horizontal flange couplings are to be connected by fitted bolts having a diameter not less than the value obtained, in mm, from the following formula:

$$d_B = 0,62 \sqrt{\frac{d_{1F}^3 k_{1B}}{n_B e_M k_{1S}}}$$

where:

- k_{1S} : material factor k_1 for the steel used for the rudder stock,
- k_{1B} : material factor k_1 for the steel used for the bolts,
- e_M : mean distance, in mm, from the bolt axes to the longitudinal axis through the coupling centre (i.e. the centre of the bolt system),
- n_B : total number of bolts, which is to be not less than 6.

Non-fitted bolts may be used provided that, in way of the mating plane of the coupling flanges, a key is fitted having a section of $(0,25d_T \times 0,10d_T)$ mm² and keyways in both the coupling flanges, and provided that at least two of the coupling bolts are fitted bolts.

The distance from the bolt axes to the external edge of the coupling flange is to be not less than $1,2 d_B$.

5.1.3 Coupling flange

The thickness of the coupling flange is to be not less than the value obtained, in mm, from the following formula:

$$t_p = d_B \sqrt{\frac{k_{1F}}{k_{1B}}}$$

where:

d_B : bolt diameter, in mm, calculated in accordance with [5.1.2], where the number of bolts n_B is to be taken not greater than 8,

k_{1F} : material factor k_1 for the steel used for the flange,

k_{1B} : material factor k_1 for the steel used for the bolts. In any case, the thickness t_p is to be not less than $0,9 d_B$.

5.1.4 Locking device

A suitable locking device is to be provided to prevent the accidental loosening of nuts.

5.2 Couplings between rudder stocks and tillers

5.2.1 Application

The requirements in Pt C, Ch 1, Sec 10 of the Rules apply.

5.2.2 General

The entrance edge of the tiller bore and that of the rudder stock cone are to be rounded or bevelled.

The right fit of the tapered bearing is to be checked before final fit up, to ascertain that the actual bearing is evenly distributed and at least equal to 80% of the theoretical bearing area; push-up length is measured from the relative positioning of the two parts corresponding to this case.

The required push-up length is to be checked after releasing of hydraulic pressures applied in the hydraulic nut and in the assembly

5.2.3 Keyless couplings through special devices

The use of special devices for frictional connections, such as expansible rings, may be accepted by the Society on a case-by-case basis provided that the following conditions are complied with:

- evidence that the device is efficient (theoretical calculations and results of experimental tests, references of behaviour during service, etc.) are to be submitted to the Society
- the torque transmissible by friction is to be not less than $2 M_{TR}$
- design conditions and strength criteria are to comply with [5.2.1]
- instructions provided by the manufacturer are to be complied with, notably concerning the pre-stressing of the tightening screws.

5.3 Cone couplings between rudder stocks and rudder blades with key

5.3.1 General

For cone couplings without hydraulic arrangements for assembling and disassembling the coupling, a key is to be fitted having keyways in both the tapered part and the rudder gudgeon.

The key is to be machined and located on the fore or aft part of the rudder. The key is to be inserted at half-thickness into stock and into the solid part of the rudder.

5.3.2 Tapering and coupling length

Cone couplings without hydraulic arrangements for mounting and dismounting the coupling should have a taper on diameter in compliance with the following formula:

$$\frac{1}{12} \leq \frac{d_u - d_0}{t_s} \leq \frac{1}{8}$$

where:

d_u, t_s, d_0 : geometrical parameters of the coupling, defined in Fig 4.

The cone shapes are to fit exactly. The coupling length t_s is to be, in general, not less than $1,5d_u$.

5.3.3 Dimensions of key

The shear area of the key, in cm^2 , is not to be less than:

$$a_s = \frac{17,55Q_F}{d_k R_{eH1}}$$

where:

Q_F : design yield moment of rudder stock, from the following formula:

$$Q_F = 0,02664 \frac{d_T^3}{k_1}$$

Where the actual diameter d_{Ta} is greater than the calculated d_T , the diameter d_{Ta} is to be used. However d_{Ta} applied to the above formula need not be taken greater than $1.145d_T$:

d_T : rudder stock diameter, in mm, subject to torque only (see 4.2.1)

d_k : mean diameter of the conical part of the rudder stock, in mm, at the key

R_{eH1} : minimum yield stress of the key material, in N/mm^2

The effective surface area, in cm^2 , of the key (without rounded edges) between key and rudder stock or cone coupling is not to be less than:

$$a_k = \frac{5Q_F}{d_k R_{eH2}}$$

where:

R_{eH2} : minimum yield stress of the key, stock or coupling material, in N/m^2 , whichever is the less.

5.3.4 Slugging nut

The cone coupling is to be secured by a slugging nut, whose dimensions are to be in accordance with the following formulae:

$$d_G \geq 0,65 d_u$$

$$t_N \geq 0,60 d_G$$

$$d_N \geq 1,2 d_0 \text{ and, in any case, } d_N \geq 1,5 d_G$$

where:

d_G, t_N, d_N, d_1, d_0 : geometrical parameters of the coupling, defined in Fig 4.

The above minimum dimensions of the locking nut are only given for guidance, the determination of adequate scantlings being left to the Designer.

The nut is to be secured, e.g. by a securing plate as shown in Fig 4.

5.3.5 Push-up

It is to be proved that 50% of the design yield moment is solely transmitted by friction in the cone couplings. This can be done by calculating the required push-up pressure and push-up length according to Pt B, Ch 10, Sec 1, [5.4.3] and [5.4.4] of the Rules for a torsional moment $Q'_F = 0,5Q_F$.

Figure 4 : Geometry of cone coupling with key

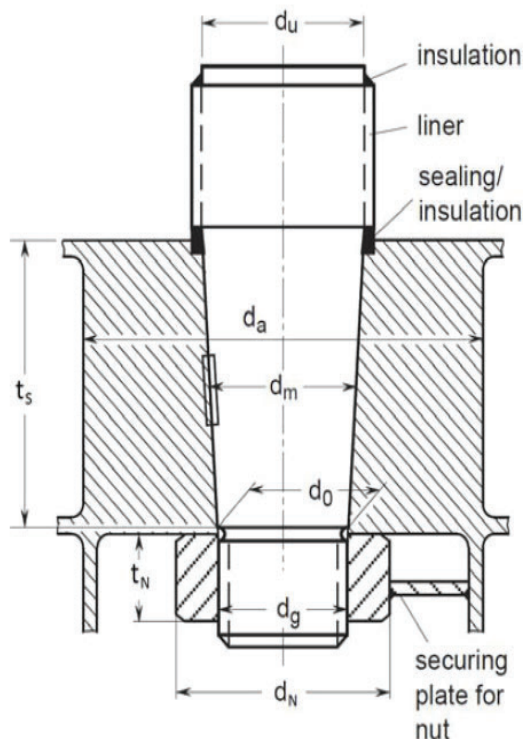

5.3.6 Rudder torque transmitted entirely by the key

Notwithstanding the requirements in [5.3.3] and [5.3.5], where a key is fitted to the coupling between stock and rudder and it is considered that the entire rudder torque is transmitted by the key at the couplings, the scantlings of the key as well as the push-up force and push-up length are to be evaluated on a case by case basis. The general criteria for the scantlings of the key are given by the following formulae.

The shear area of the key, in cm^2 , is not to be less than:

$$a_s = \frac{35,1Q_F}{d_k R_{eH1}}$$

The effective surface area, in cm^2 , of the key (without rounded edges) between key and rudder stock or cone coupling is not to be less than:

$$a_k = \frac{10Q_F}{d_k R_{eH2}}$$

5.4 Cone couplings between rudder stocks and rudder blades with special arrangements for mounting and dismounting the couplings

5.4.1 General

See Pt B, Ch 10, Sec 1, [5.4] of the Rules.

5.5 Vertical flange couplings

5.5.1

See Pt B, Ch 10, Sec 1, [5.5] of the Rules.

5.6 Couplings by continuous rudder stock welded to the rudder blade

5.6.1

When the rudder stock extends through the upper plate of the rudder blade and is welded to it, the thickness of this plate in the vicinity of the rudder stock is to be not less than $0,20 d_1$, where d_1 is defined in [5.1.1].

5.6.2

The welding of the upper plate of the rudder blade with the rudder stock is to be made with a full penetration weld and is to be subjected to non-destructive inspection through dye penetrant or magnetic particle test and ultrasonic testing.

The throat weld at the top of the rudder upper plate is to be concave shaped to give a fillet shoulder radius as large as practicable. This radius is to be not less than $0,20 d_1$, where d_1 is defined in [5.1.1].

5.7 Skeg connected with rudder trunk

5.7.1

See Pt B, Ch 10, Sec 1, [5.7] of the Rules.

6 Rudder stock bearings

6.1 General

6.1.1

The mean bearing pressure acting on the rudder stock bearing is to be in compliance with the following formula:

$$p_F \leq p_{F,ALL}$$

where:

p_F : mean bearing pressure acting on the rudder stock bearings, in N/mm^2 , equal to:

$$p_F = \frac{F_{A1}}{d_m h_m}$$

F_{A1} : force acting on the rudder stock bearing, in N, calculated as specified in 3.1.3,

d_m : actual inner diameter, in mm, of the rudder stock bearings,

h_m : bearing length, in mm. For the purpose of this calculation it is to be taken not greater than $1,2d_m$, for spade rudders,

$p_{F,ALL}$: allowable bearing pressure, in N/mm^2 , defined in.

Values greater than those given in Tab 3 may be accepted by the Society in accordance with the Manufacturer's specifications if they are verified by tests, but in no case more than $10 N/mm^2$.

The minimum thickness of the lower bearing is to be $0,2d_{TF}$ and the minimum height is to be at least d_m .

Table 3 : Allowable bearing pressure

Bearing material	$p_{F,ALL}$, in N/mm^2
Lignum vitae	2,5
White metal, oil lubricated	4,5
Synthetic material with hardness between 60 and 70 Shore D (1)	5,5
Steel, bronze and hot-pressed bronze-graphite materials (2)	7,0
(1) Indentation hardness test at 23°C and with 50% moisture to be performed according to a recognised standard. Type of synthetic bearing materials is to be approved by the Society.	
(2) Stainless and wear-resistant steel in combination with stock liner approved by the Society.	

6.1.2

An adequate lubrication of the bearing surface is to be ensured.

6.1.3

The manufacturing tolerance t_0 on the diameter of metallic supports is to be not less than the value obtained, in mm, from the following formula:

$$t_0 = \frac{d_m}{1000} + 1$$

In the case of non-metallic supports, the tolerances are to be carefully evaluated on the basis of the thermal and distortion properties of the materials employed.

The tolerance on support diameter is to be not less than 1,5 mm, unless a smaller tolerance is supported by the manufacturer's recommendation and there is documented evidence of satisfactory service history with a reduced clearance.

6.1.4

Liners and bushes are to be fitted in way of bearings. The minimum thickness of liners and bushes is to be equal to:

- $t_{min} = 8$ mm for metallic materials and synthetic material
- $t_{min} = 22$ mm for lignum material.

7 Rudder blade scantlings

7.1 General

7.1.1 Application

The requirements in [7.1] to [7.6] apply to streamlined rudders and, when applicable, to rudder blades of single plate rudders.

7.1.2 Rudder blade structure

The structure of the rudder blade is to be such that stresses are correctly transmitted to the rudder stock and pintles. To this end, horizontal and vertical web plates are to be provided.

Horizontal and vertical webs acting as main bending girders of the rudder blade are to be suitably reinforced.

7.1.3 Access openings

Streamlined rudders, including those filled with pitch, cork or foam, are to be fitted with plug-holes and the necessary devices to allow their mounting and dismounting.

If necessary, the rudder blade plating is to be strengthened in way of these openings.

The corners of openings intended for the passage of the rudder horn heel and for the dismantling of pintle or stock nuts are to be rounded off with a radius as large as practicable.

Where the access to the rudder stock nut is closed with a welded plate, a full penetration weld is to be provided.

7.2 Strength checks

7.2.1 Bending stresses

For the generic horizontal section of the rudder blade it is to be checked that the bending stress σ , in N/mm², induced by the loads defined in [3.1], is in compliance with the following formula:

$$\sigma \leq \sigma_{ALL}$$

where:

σ_{ALL} : allowable bending stress, in N/mm², specified in Tab 4.

Table 4 : Allowable stresses for rudder blade scantlings

Allowable bending stress σ_{ALL} in N/mm ²	Allowable shear stress τ_{ALL} in N/mm ²	Allowable equivalent stress $\sigma_{E,ALL}$ in N/mm ²
110/k	50/k	120/k

7.2.2 Shear stresses

For the generic horizontal section of the rudder blade it is to be checked that the shear stress τ , in N/mm², induced by the loads defined in [3.1], is in compliance with the following formula:

$$\tau \leq \tau_{ALL}$$

where:

τ_{ALL} : allowable shear stress, in N/mm², specified in Tab 4.

7.2.3 Combined bending and shear stresses

For the generic horizontal section of the rudder blade it is to be checked that the equivalent stress σ_E is in compliance with the following formula:

$$\sigma_E \leq \sigma_{E,ALL}$$

where:

σ_E : equivalent stress induced by the loads defined in [3.1], to be obtained, in N/mm², from the following formula:

$$\sigma_E = \sqrt{\sigma^2 + 3\tau^2}$$

Where unusual rudder blade geometries make it practically impossible to adopt ample corner radiuses or generous tapering between the various structural elements, the equivalent stress σ_E is to be obtained by means of direct calculations aiming at assessing the rudder blade areas where the maximum stresses, induced by the loads defined in [3.1], occur,

σ : bending stress, in N/mm²,

τ : shear stress, in N/mm²,

$\sigma_{E,ALL}$: allowable equivalent stress, in N/mm², specified in Tab 4.

7.3 Rudder blade plating

7.3.1 Plate thickness

The thickness of each rudder blade plate panel is to be not less than the value obtained, in mm, from the following formula:

$$t_f = \left(5,5s\beta \sqrt{kT + \frac{C_R 10^{-4}}{A}} \right) \sqrt{k} + 2,5$$

where:

β : coefficient equal to:

$$\beta = \sqrt{1,1 - 0,5 \left(\frac{s}{b_L} \right)^2}$$

to be taken not greater than 1,0 if $b_L/s > 2,5$

s : length, in m, of the shorter side of the plate panel,

b_L : length, in m, of the longer side of the plate panel

T : moulded draught, in m.

7.3.2 Thickness of the top and bottom plates of the rudder blade

The thickness of the top and bottom plates of the rudder blade is to be not less than the thickness t_f defined in [7.3.1], without being less than 1,2 times the thickness obtained from [7.3.1] for the attached side plating.

Where the rudder is connected to the rudder stock with a coupling flange, the thickness of the top plate which is welded in extension of the rudder flange is to be not less than 1,1 times the thickness calculated above.

7.3.3 Web spacing

The spacing between horizontal web plates is to be not greater than 1,20 m.

Vertical webs are to have spacing not greater than twice that of horizontal webs.

7.3.4 Web thickness

Web thickness is to be at least 70% of that required for rudder plating and in no case is it to be less than:

- 8 mm for vessels $\geq 500\text{GT}$
- 6 mm for vessels $< 500\text{GT}$
- 5 mm for vessels of less than 24m in L_{LL} or L_H

except for the upper and lower horizontal webs, for which the requirements in [7.3.2] apply.

When the design of the rudder does not incorporate a main-piece, this is to be replaced by two vertical webs closely spaced, having thickness not less than $1,4 t_f$ and the thickness of rudder plating to be at least $1,3 t_f$. One vertical web only may be accepted provided its thickness is at least twice that of normal webs.

7.3.5 Thickness of side plating and vertical web plates welded to solid part or to rudder flange

The thickness, in mm, of the vertical web plates welded to the solid part where the rudder stock is housed, or welded to the rudder flange, as well as the thickness of the rudder side plating under this solid part, or under the rudder coupling flange, is to be not less than the value obtained, in mm, from [7.3.4].

7.3.6 Welding

The welded connections of blade plating to vertical and horizontal webs are to be in compliance with the applicable requirements of Part D of the Rules.

Where the welds of the rudder blade are accessible only from outside of the rudder, slots on a flat bar welded to the webs are to be provided to support the weld root, to be cut on one side of the rudder only.

7.4 Connections of rudder blade structure with solid parts in forged or cast steel

7.4.1 General

See Pt B, Ch 10, Sec 1, [7.4] of the Rules.

7.5 Connection of the rudder blade with the rudder stock by means of horizontal flanges

7.5.1 Minimum section modulus of the connection

The section modulus of the cross-section of the structure of the rudder blade which is directly connected with the flange, which is made by vertical web plates and rudder blade plating, is to be not less than the value obtained, in cm^3 , from the following formula:

$$w_s = 1,3 d_{TF}^3 10^{-4}$$

where d_{TF} , in mm, is to be calculated in compliance with the requirements in [4.2], taken k_1 equal to 1.

7.5.2 Actual section modulus of the connection

The section modulus of the cross-section of the structure of the rudder blade which is directly connected with the flange is to be calculated with respect to the symmetrical axis of the rudder.

For the calculation of this actual section modulus, the length of the rudder cross-section equal to the length of the rudder flange is to be considered.

7.5.3 Welding of the rudder blade structure to the rudder blade flange

The welds between the rudder blade structure and the rudder blade flange are to be full penetrated (or of equivalent strength) and are to be 100% inspected by means of non-destructive tests.

Where the full penetration welds of the rudder blade are accessible only from outside of the rudder, a backing flat bar is to be provided to support the weld root.

The external fillet welds between the rudder blade plating and the rudder flange are to be of concave shape and their throat thickness is to be at least equal to 0,5 times the rudder blade thickness.

Moreover, the rudder flange is to be checked before welding by non-destructive inspection for lamination and inclusion detection in order to reduce the risk of lamellar tearing.

7.5.4 Thickness of side plating and vertical web plates welded to the rudder flange

The thickness of the vertical web plates directly welded to the rudder flange as well as the plating thickness of the rudder blade upper strake in the area of the connection with the rudder flange is to be not less than $1,4 t_f$ and $1,3 t_f$ respectively.

7.6 Single plate rudders

7.6.1 Mainpiece diameter

The mainpiece diameter is to be obtained from the formulae in [4.2].

In any case, the mainpiece diameter is to be not less than the stock diameter.

For spade rudders the lower third may taper down to 0,75 times the stock diameter.

7.6.2 Blade thickness

The blade thickness is to be not less than the value obtained, in mm, from the following formula:

$$t_B = 1,5sV_{AV}\sqrt{k} + 2,5$$

where:

s : spacing of stiffening arms, in m, to be taken not greater than 1 m (see Fig 5).

7.6.3 Arms

The thickness of the arms is to be not less than the blade thickness.

The section modulus of the generic section is to be not less than the value obtained, in cm^3 , from the following formula:

$$Z_A = 0,5sC_H^2V_{AV}^2k$$

where:

- C_H : horizontal distance, in m, from the aft edge of the rudder to the centreline of the rudder stock (see Fig 5),
- s : defined in [7.6.2].

Figure 5 : Single plate rudder

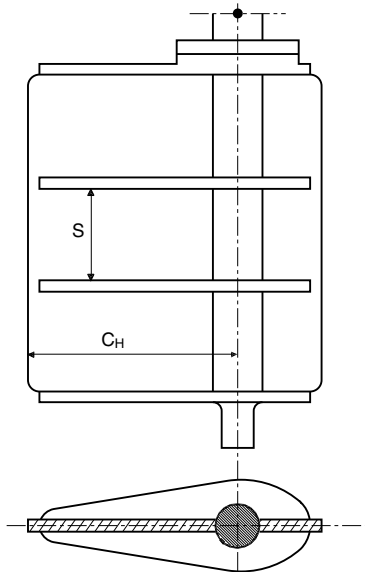

The radius is to be checked with a template for accuracy. Four profiles at least are to be checked. A report is to be submitted to the Surveyor.

Rudder trunks comprising of materials other than steel are to be specially considered by the Society.

The rudder trunk is to be of adequate thickness (in general equivalent to the thickness of the hull in that area) and duly connected to the hull to the satisfaction of the Surveyor.

If the rudder stock is lined in way of the trunk bearing (for instance with stainless steel brush), the lining is to be shrunk on.

Figure 6 : Fillet shoulder radius

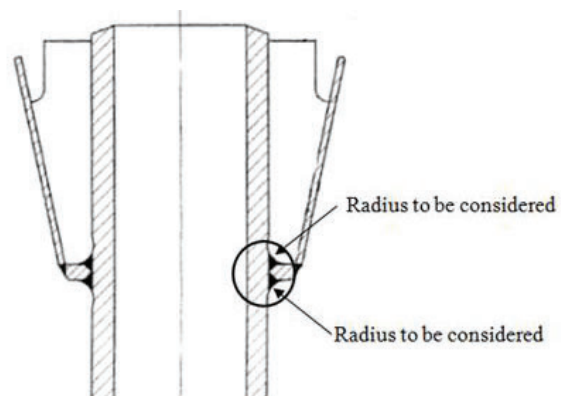

8 Rudder trunk

8.1 Materials, welding and connection to the hull

8.1.1

This requirement applies to both trunk configurations (extending or not below stern frame).

The steel grade used for the rudder trunk is to be of weldable quality, with a carbon content not exceeding 0,23% on ladle analysis and a carbon equivalent C_{ER} not exceeding 0,41.

Plating materials for rudder trunks are in general not to be of lower grade than corresponding to class II as defined in the Rules.

In general, the fillet shoulder radius r , in mm, is to be as large as practicable (see Fig 6) and to comply with the following formulae:

$$r = 60 \text{ mm when } \sigma_B \geq 40 / k \text{ N/mm}^2,$$

$$r = 0,1 d_{TF} \text{ when } \sigma_B < 40 / k \text{ N/mm}^2,$$

without being less than 30 mm,

where:

d_{TF} : rudder stock diameter, in mm,

σ_B : bending stress in the rudder trunk, in N/mm^2 .

The radius may be obtained by grinding. If disk grinding is carried out, score marks are to be avoided in the direction of the weld.

8.1.2 Strength check

Where the rudder stock is arranged in a trunk in such a way that the trunk is stressed by forces due to rudder action, the scantling of the trunk are to be such that:

- the equivalent stress σ_{E_r} in N/mm^2 , due to bending and shear does not exceed $0,35 R_{EH}$,
- the bending stress σ_B , in N/mm^2 , on welded rudder trunk is to be in compliance with the following formula:

$$\sigma_B \leq 80 / k \text{ where } k \text{ is not to be taken less than } 0,7,$$

where:

R_{EH} : yield stress, in N/mm^2 , of the material used

For calculation of bending stress, the span to be considered is the distance between the mid height of the lower rudder stock bearing and the point where the trunk is clumped into the shell or bottom of the skeg.

9 Simplex rudder shaft

9.1 General

9.1.1

See Pt B, Ch 10, Sec 1, [9] of the Rules.

10 Steering nozzles

10.1 General

10.1.1

See Pt B, Ch 10, Sec 1, [10] of the Rules.

11 Azimuth propulsion system

11.1 General

11.1.1

See Pt B, Ch 10, Sec 1, [11] of the Rules.

SECTION 4 EQUIPMENT

1 Equipment Number

1.1

1.1.1

The equipment of the vessel is to be as stipulated in Tab 1 based on the Equipment Number EN given in the requirements of Part B, Ch 10, Sec 4 of the Rules. Alternatively, *Tasneef*, taking into account the specific service and operational area for which the vessel is classed, may accept arrangements other than those above, following a request with grounds from the Interested Parties.

1.1.2 (1/1/2025)

In case the vessel is normally moored at quay and is thus only exceptionally anchored, the second anchor and attached chain end length (or guy pendant) may be stored ashore and not necessarily onboard.

Moreover, for vessels having a restricted navigation notation (NAV 150 or lower), the required number of anchors may be reduced to 1. The mass of the anchor may be reduced according to the scheme in Tab 2.

2 Anchors

2.1

2.1.1 (1/1/2025)

The mass per anchor given in Tab 1 applies to normal type anchors and may be reduced to 75% of that shown when high holding power anchors are used. Moreover, for vessels having a restricted navigation notation (NAV 60 or lower),

the mass per anchor given in Tab 1 may be also reduced, for $EN \leq 110$, according to the scheme in Tab 2:

Anchors are generally to be arranged in hawse pipes or, in any event, so that the chain cables can be easily and rapidly paid out. The chafing lips, and in any case the zone at the shell and deck, are to have radius adequate to the diameter of the chain cable; in general, this is to be not less than 8 times the diameter of the chain cable.

3 Chain cables and ropes

3.1

3.1.1 The chain cable diameters shown in Tab 1 refer to chain cables made of mild steel, grade Q1. The total length of chain cable for the anchor may be provided using a length of at least 10 m, having the required diameter, connected at one end to the anchor and at the other to a wire or natural fibre rope having the required chain cable length and breaking load at least equal to that of the chain cable.

If synthetic fibre ropes are used to replace both the chain cable and the mooring and/or warping lines, the breaking load is to be calculated as stated in Part B, Ch 10, Sec 4 of the Rules.

4 Windlass

4.1

4.1.1 The windlass is to be suitable for the size of chain cable and is generally to be power driven.

Table 1

Equipment number EN	Number of anchors	Mass of each anchor (kg)	Chain Cable			Lines		
			Diameter (mm)		Total length (m)	Breaking load (kN)		Length (m)
			studless	with stud		warping	mooring	
30	2	28	9,5	-	110	31	18	60
40	2	48	11	-	110	46	21	65
50	2	58	11	-	165	60	24	70
60	2	78	12,5	-	165	71	26	75
70	2	99	14	-	165	80	28	80
80	2	117	14	12,5	190	88	30	85
90	2	133	16	12,5	190	94	33	88
100	2	149	17,5	14	190	99	35	92
110	2	156	17,5	14	220	104	37	97
120	2	167	19	16	220	108	38	102
130	2	177	19	16	220	112	39	104
140	2	187	19	16	220	114	40	107
150	2	195	20,5	17,5	220	116	41	110
160	2	205	20,5	17,5	220	118	42	113

Note 1:When the calculated EN is intermediate between two values given in the Table, the masses of the anchors and the breaking loads of the lines may be obtained by linear interpolation; the other elements are to be assumed based on the higher EN.

Note 2:Natural or synthetic fibre ropes with diameter under 20 mm are not permitted.

Note 3:The breaking loads of the lines refer to steel wires or natural fibre ropes. For synthetic fibre ropes, the breaking load is to be determined in accordance with Part B, Chapter 10, Sec 4 of the Rules.

Table 2 (1/1/2025)

Navigation Notation	Required Anchor Mass
NAV 60 (EN ≤ 110)	Mass of Tab 1 / 1,15
NAV 30 or NAV 3 (EN ≤ 110)	Mass of Tab 1 / 1,25

SECTION 5

NON-STRUCTURAL FUEL TANKS

1 General

1.1

1.1.1 Tanks for liquid fuel are to be designed and constructed so as to withstand, without leakage, the dynamic stresses to which they will be subjected. They are to be fitted with internal diaphragms, where necessary, in order to reduce the movement of liquid.

Tanks are to be arranged on special supports on the hull and securely fastened to them so as to withstand the stresses induced by movement of the vessel.

Tanks are to be arranged so as to be accessible at least for external inspection and check of piping.

Where their dimensions permit, tanks are to include openings allowing at least the visual inspection of the interior.

In tanks intended to contain fuel with a flashpoint below 55°C determined using the closed cup test (petrol, kerosene and similar), the above openings are to be arranged on the top of the tank.

Such tanks are to be separated from accommodation spaces by integral gastight bulkheads. Tanks are to be arranged in adequately ventilated spaces equipped with a mechanical air ejector.

Upon completion of construction and fitting of all the pipe connections, tanks are to be subjected to a hydraulic pressure test with a head equal to that corresponding to 2 m above the tank top or that of the overflow pipe, whichever is the greater.

At the discretion of Tasneef, leak testing may be accepted as an alternative, provided that it is possible, using liquid solutions of proven effectiveness in the detection of air leaks, to carry out a visual inspection of all parts of the tanks with particular reference to pipe connections.

2 Metallic tanks

2.1 General

2.1.1 Tanks intended to contain diesel oil are to be made of stainless steel, nickel copper, steel or aluminium alloys.

Steel tanks are to be suitably protected internally and externally so as to withstand the corrosive action of the salt in the atmosphere and the fuel they are intended to contain.

The upper part of tanks is generally not to have welded edges facing upwards or be shaped so as to accumulate water or humidity.

To this end, zinc plating may be used, except for tanks intended to contain diesel oil, for which internal zinc plating is not permitted.

Tanks are to be effectively earthed.

2.2 Scantlings

2.2.1 The thickness of metallic tank plating is to be not less than the value t , in mm, given by the following formula:

$$t = 4 \cdot s \cdot (h_s \cdot K)^{0.5}$$

where:

s : stiffener spacing, in m;

h_s : static internal design head, in m, to be assumed as the greater of the following values:

- vertical distance from the pdr (see below) to a point located 2 m above the tank top
- two-thirds of the vertical distance from the pdr to the top of overflow

K : $\frac{235}{R_s}$ where R_s is the minimum yield stress, in N/mm², of the tank material. Where light alloys are employed, the value of R_s to be assumed is that corresponding to the alloy in the annealed condition;

pdr : point of reference, intended as the lower edge of the plate, or, for stiffeners, the centre of the area supported by the stiffener.

In any case the thickness of the tank is to be not less than 2 mm for steel and not less than 3 mm for light alloy.

The section modulus of stiffeners is to be not less than the value Z , in cm³, given by the formula:

$$Z = 4 \cdot s^2 \cdot h_s \cdot K$$

where:

S : stiffener span, in m.

3 Non-metallic tanks

3.1 General

3.1.1 Fuel tanks may be made of non-metallic materials.

Mechanical tests are to be carried out on samples of the laminate "as is" and after immersion in the fuel oil at ambient temperature for a week. After immersion the mechanical properties of the laminate are to be not less than 80% of the value of the sample "as is".

For scantling calculations the mechanical characteristics obtained by the mechanical tests are to be assumed.

3.2 Scantlings

3.2.1

The scantlings of non-metallic tanks will be specially considered by Tasneef on the basis of the characteristics of the material proposed and the results of strength tests performed on a sample.

In general, for tanks made of composite material, the thickness t , in mm, of the plating and the module of stiffeners Z , in cm^3 , are to be not less, respectively, than the values:

$$t = 6 \cdot s \cdot (h_s \cdot k_{of})^{0.5}$$

$$Z = 15 \cdot s \cdot S^2 \cdot h_s \cdot K_0$$

where:

k_{of} , K_0 : as defined in Chapter 4;

s , S , h_s : as defined in [2.2].

In any case, the thickness is to be not less than 8 mm with reinforcement not less than 30% in weight fraction.

The surface of the tanks is to be internally coated with resin capable of withstanding hydrocarbons and externally coated with self-extinguishing resin.

The self-extinguishing characteristic is to be ascertained by a test carried out according to ASTM D635 on specimens having all their surface impregnated with the self-extinguishing resin used. During such test the flame speed is not to exceed 6 cm/min.

4 Tests on tanks

4.1 General

4.1.1 Prior to their installation on board, tanks are to be subjected to a hydraulic pressure test with a head equal to

that corresponding to 2 m above the tank top or that of the overflow pipe, whichever is the greater.

At the discretion of Tasneef, leak testing may be accepted as an alternative.

4.2 Leak testing

4.2.1 Leak testing is to be carried out by applying an air pressure of 0,015 MPa.

Prior to inspection of the tightness of welding, in the case of metallic tanks and pipe connections, it is recommended that the air pressure is raised to 0,02 MPa and kept at this level for about 1 hour. The level may then be lowered to the test pressure before carrying out the welding tightness check of the tank and connections by means of a liquid solution of proven effectiveness in the detection of air leaks.

The test may be supplemented by arranging a pressure gauge and checking that the reading does not vary over time.

Leak testing is to be performed before any primer and/or coating is applied. In the case of tanks made of composite material, the test is to be carried out before the surface is externally coated with self-extinguishing resin.

SECTION 6

TESTING

1 Application

1.1

1.1.1 The requirements in Pt B, Ch 12, Sec 3 of the Rules as far it is practicable and reasonable apply.

APPENDIX 1

BUOYANCY MATERIALS

1 Requirements

1.1

1.1.1

By buoyancy material is meant a low density material e.g. foam with a specific gravity of less than 1.0, which provides buoyancy to the vessel when flooded.

1.1.2

The water absorption of buoyancy materials is not to exceed 8% by volume after being submerged for 8 days according

to ISO 2896. Material complying with IMO Resolution MSC.81(70) is to be deemed to satisfy this requirement.

1.1.3

Buoyancy materials are to be resistant to liquids e.g. petrol fuel. The requirement may be omitted if the material is totally encapsulated when fitted.

1.1.4

Results from tests or compliance to Resolution are to be documented.

APPENDIX 2

RIB COLLARS

1 General

1.1

1.1.1

Fabrics for RIB collars are to be selected by the manufacturer according to the stresses to which the vessel is to be subjected (shape, dimensions, maximum load, installed power etc.), and also to the intended service conditions.

Use under normal seagoing conditions is not to materially impair their performance.

1.1.2

Fabrics for RIB collars are to be tested according to ISO 6185-3 section 4.2.2. The test results are to be documented.

1.1.3

RIB collars are to retain their full serviceability within the operating temperature range of -20°C to +60°C.

Part B
Hull and Stability

Chapter 2

GLASS REINFORCED PLASTIC HULL

SECTION 1 MATERIAL AND CONSTRUCTION

SECTION 2 DESIGN LOADS AND HULL SCANTLING

Symbols used in chapter 2

- FP_{LL}** : “forward freeboard perpendicular”. The forward freeboard perpendicular is to be taken at the forward end of the length L_{LL} and is to coincide with the foreside of the stem on the waterline on which the length L_{LL} is measured.
- AP_{LL}** : “after freeboard perpendicular”. The after freeboard perpendicular is to be taken at the after end of the length L_{LL} .

SECTION 1

MATERIAL AND CONSTRUCTION

1 Structures

1.1

1.1.1 The main raw materials are to be type approved by Tasneef.

It may be accepted as equivalent that main raw materials are individually inspected by Tasneef. In such a case, each batch being used is submitted to tests, the conditions and scope of which are stipulated by the Tasneef Surveyor.

a) Reinforcement fibres

Fibres for reinforcement may be textile glass or aramid or carbon fibres or other fibres.

Products laid on a surface, such as size, binder and coupling finish, are to ensure cohesion between fibres and resins.

During manufacturing, the shipyard is to ensure that reinforcement materials are free from scrap matter and without defects, detrimental to their use.

b) Resins

Resins are to be capable of withstanding ageing in marine environments and industrial atmospheres.

Resins are to be used within the limits fixed by the Manufacturer. In this respect, the Surveyor may ask for any relevant proof.

c) Core materials for sandwich laminates

Expanded foams contributing to sandwich laminate strength are to be of the closed cell type and compatible with the resins used.

Expanded polystyrenes may be used only as filling or buoyancy materials.

d) Additives

Fillers and pigments are to affect neither the conditions of polymerisation of the impregnation resin nor its mechanical characteristics. The percentage of both of them is not to exceed, as a rule, 10% of the mass of resin, with a maximum of 2% for thixotropic agents and 5% for flame retarders.

The use of microspheres is subject to special examination.

The type and proportions of catalyst and accelerator are to be adjusted in any case to the conditions of work (production rate) and ambient atmosphere (temperature).

In order to ensure complete curing, the builder is to respect the indications of the resin Manufacturer, particularly for the ratio of catalyst.

e) Materials for integrated structures

These are elements entirely covered with laminate, and used for reinforcement, moulding, or as lamination support for stiffeners, for example.

The metals used are to withstand seawater and fuel corrosion; they are to be of good quality and are not to have any influence on resin curing.

They are to undergo appropriate preparation to improve bonding with the resin.

As a rule, wood reinforcements are to be of a plywood type with good seawater resistance. The use of timber is subject to a special examination.

1.1.2 Tests on laminates

The shipyard is to make samples representative of shell materials and if possible of other parts of the structure, taking into account the type and size of vessel.

If sister vessels are built at the same shipyard, and provided that raw materials are not changed, the frequency of samples for testing is determined by Tasneef.

These test samples are to be submitted to a laboratory approved by Tasneef to undergo mechanical and physico-chemical tests, as defined below.

In general, tests are to be carried out according to the standards indicated below, or other recognized standards previously agreed upon with Tasneef.

These tests are to show that laminate characteristics are at least equivalent to the theoretical values given by direct calculation following the method given in [1.1.3]. Otherwise, supplementary tests may be required.

Tasneef reserves the right to require tests different from those defined below, if particular materials or unusual manufacturing process are used.

Tests are to be carried out on a panel, the composition of which is to be the same as that of a shell plating area, without gel-coat.

Identification of the panel is given by the following elements:

- exact name of the resin, with its specific gravity, elasticity modulus, and breaking stress in curing state,
- description of elementary layers,
- characteristics of the laminate (e.g. layer type, direction),
- direction of the panel in respect of longitudinal axis of the vessel and indication of direction for warp and weft for the rovings in respect of the same axis.

Conditioning of laminate panels, preparation of testpieces, dimensional measurement of testpieces and the tests defined below are to be carried out according to recognized standards.

Tests are to be carried out on testpieces taken out of the panel in two perpendicular directions. The number of testpieces for each direction is given by the standard used for the particular test.

For each group of testpieces and for each result, the value to consider is the average obtained from the number of tested pieces, provided that the minimum value is not less than 0,9 times the mean value. Otherwise, the value to consider is determined by Tasneef, taking testing conditions and dis-persion of results into account.

Mechanical characteristics are to be obtained from dry testpieces, i.e. not conditioned in water.

In general, the following tests are to be carried out:

- single skin laminates: tensile tests, bending tests (three-point method), measurement of specific gravity and percentage of reinforcement in mass,
- sandwich laminates: bending tests (four-point method), and, for each skin, tensile tests, measurement of specific gravity and percentage of reinforcement in mass.

Bending tests are to be carried out with the load applied either on the gel-coat side or on the opposite side. The choice of the side is to be decided in accordance with Tasneef, so that the failure mode of the testpiece is representative of the case of scantlings of the plating.

Test results are to be shown in a test report, mentioning the tests in a) to c).

a) Tensile tests

In general, these tests are to be carried out for single skin laminates and the skins of sandwich laminates.

The applicable standard is:

- ISO 527.

For each testpiece, the test report is to provide the following information:

- reference of the standard used for the test,
- widths and thicknesses of the testpiece, in mm,
- length between fixed ends, in mm,
- load (in N),
- elongation curve (in mm),
- breaking load, in N,
- tensile breaking stress, in N/mm²,
- tangential initial elasticity modulus, in N/mm²,
- other items of information required by the standard, if necessary.

If breaking occurs in several steps, the value taken into account is the first break obtained from the load-elongation curve.

The test report is also to indicate the mean value of the breaking load, breaking tensile strength and tangential initial elasticity modulus.

b) Bending tests

In general, bending tests using the three-point method are to be carried out only for the single skin laminates.

The applicable standard is:

- ISO 178.

In general, bending tests using the four-point method are to be carried out only for sandwich laminates.

The applicable standard is:

- ASTM C 393.

For each testpiece, the test report is to provide the following information:

- reference of the standard used for the test,
- widths and thicknesses of the testpiece, in mm,
- length of the span between supports, in mm,
- for the four-point method: location of the points where the load is applied,
- load (in N),
- deflection (in mm) curve,
- breaking load, in N, and failure mode,
- bending breaking strength, in N/mm², for single skin laminate tests,
- bending breaking strength of skin and shear breaking strength of core for sandwich laminate tests, both in N/mm²,
- other items of information required by the standard, if necessary.

If breaking occurs in several steps, the value taken into account is the first break obtained from the load-deflection curve.

The test report is also to indicate the mean value of the breaking load and breaking strength.

c) Mass density and percentage of reinforcement

In general, these tests are to be carried out for single skin laminates and the skins of sandwich laminates.

The applicable standards are:

- ASTM D 792,
- ASTM D 3171.

For each testpiece, the test report is to provide the following information:

- reference of the standard used for the test,
- dimensions, in mm, of the testpiece,
- mass of the test-piece, in g,
- mass by unit of area of the testpiece, in g/m²,
- specific density, in g/m³,
- mass of reinforcement of the testpiece, in g,
- mass of reinforcement by unit of area, in g/m²,
- percentage of reinforcement in mass,
- other items of information required by the standard, if necessary.

The test report is also to indicate the mean value of the mass by unit of area, in g/m², specific gravity, in g/m³, mass of reinforcement by unit of area, in g/m², and percentage of reinforcement in mass.

1.1.3 Estimation of mechanical characteristics of materials

The meanings of the symbols used below are as follows:

- Ψ : content in mass of reinforcement in a layer,
- ϕ : content in volume of reinforcement in a layer, defined in (a) below,
- μ_0 : vacuum content, equal to 0, if there is no available information,
- E_1 : Young's modulus of a layer with unidirectional fibres, parallel to fibres, in N/mm², defined in (a) below,

- E_2 : Young's modulus of a layer with unidirectional fibres, perpendicular to fibres, in N/mm², defined in (a) below,
- ν_{12}, ν_{21} : Poisson's ratios of a layer with unidirectional fibres, defined in (a) below,
- G_{12} : Coulomb's modulus of a layer with unidirectional fibres, in N/mm², defined in (a) below,
- ρ_v : specific gravity of reinforcement, in g/cm³,
- ρ_r : specific gravity of resin, in g/cm³,
- E_{1v} : Young's modulus of reinforcement in the direction parallel to fibres, in N/mm²,
- E_{2v} : Young's modulus of reinforcement in the direction perpendicular to fibres, in N/mm²,
- E_r : Young's modulus of resin, in N/mm²,
- ν_v : Poisson's ratio of reinforcement,
- ν_r : Poisson's ratio of resin,
- G_r : Coulomb's modulus of resin, in N/mm², defined in (a) below,
- G_v : Coulomb's modulus of the reinforcement, in N/mm², as given in Tab 1.

When there is no available information, the values given in Tab 1 may be considered.

a) Elementary layer

The content in volume ϕ of reinforcement in the layer is given by the formula:

$$\phi = \frac{\Psi \cdot (1 - \mu_0)}{\Psi + (1 - \Psi) \cdot \frac{\rho_v}{\rho_r}}$$

Whatever the type of reinforcement used in a particular layer, the elastic characteristics of a layer with unidirectional fibres having the same content of reinforcement as that layer are to be calculated first:

- Young's moduli:

parallel to fibres

$$E_1 = \phi \cdot E_{1v} + (1 - \phi) \cdot E_r$$

perpendicular to fibres

$$E_2 = \frac{E_r}{1 - \nu_r^2} \cdot \frac{1 + 0,85 \cdot \phi^2}{(1 - \phi)^{1,25} + \phi \cdot \frac{E_r}{E_{2v}(1 - \nu_r^2)}}$$

- Poisson's ratios:

$$\nu_{12} = \phi \cdot \nu_v + (1 - \phi) \cdot \nu_r$$

$$\nu_{21} = \nu_{12} \cdot \frac{E_2}{E_1}$$

- Coulomb's modulus:

$$G_{12} = G_r \cdot \frac{1 + 0,6 \cdot \phi^{0,5}}{(1 - \phi)^{1,25} + \frac{G_r}{G_v} \cdot \phi}$$

where:

$$G_r = \frac{E_r}{2 \cdot (1 + \nu_r)}$$

Following any direction that forms an angle θ with the direction of fibres, Young's moduli of the elementary layer become:

$$\frac{1}{E_x} = \frac{1}{E_1} \cdot \cos^4 \theta + \left(\frac{1}{G_{12}} - \frac{2\nu_{12}}{E_1} \right) \cdot \sin^2 \theta \cdot \cos^2 \theta + \frac{1}{E_2} \cdot \sin^4 \theta$$

$$\frac{1}{E_y} = \frac{1}{E_1} \cdot \sin^4 \theta + \left(\frac{1}{G_{12}} - \frac{2\nu_{12}}{E_1} \right) \cdot \sin^2 \theta \cdot \cos^2 \theta + \frac{1}{E_2} \cdot \cos^4 \theta$$

The values of E_1 , E_2 , ν_{12} and G_{12} are calculated as above; directions x and y are defined in Fig 1.

Figure 1

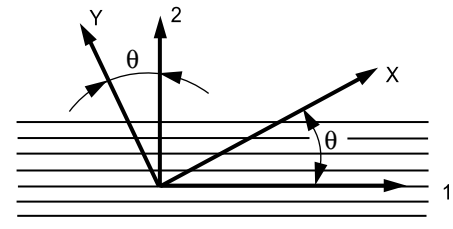

In general, the content in mass of reinforcement in a layer of mat is between 0,25 and 0,35.

Young's modulus of a layer of mat may be estimated from:

$$E_M = \frac{3}{8} \cdot E_1 + \frac{5}{8} \cdot E_2$$

In this formula, the values E_1 and E_2 are those defined above.

Woven rovings may be taffeta, cotton serge, satin, etc., warp and weft balanced or not.

In general, the content in mass of reinforcement in a woven roving reinforced layer is between 0,4 and 0,6, and the content in mass of reinforcement in a unidirectional reinforced layer is between 0,6 and 0,7.

The direction of the warp (direction 1) is to be distinguished from that of the weft (direction 2); the elastic characteristics are:

$$E_{1R} = k \cdot E_1 + (1 - k) \cdot E_2$$

$$E_{2R} = (1 - k) \cdot E_1 + k \cdot E_2$$

where k is the woven balance coefficient equal to the ratio of warp tensile strength to the sum of tensile strengths in warp and weft, E_1 and E_2 being defined above.

Generally, a layer reinforced with woven rovings may be considered as made of two perpendicular unidirectional layers, and it is possible to apply directly to them the formulae laid down above, taking into account the actual content of reinforcement in the layer.

b) Single skin laminates

A laminate is made of n layers. The characteristics of layer i of the laminate are:

t_i : thickness, in mm, regardless of direction, given by

$$t_i = \frac{P_{vi}}{(1 - \mu_0)} \cdot \left(\frac{1}{\rho_v} + \frac{1 - \Psi_i}{\Psi_i \cdot \rho_r} \right) \cdot 10^{-3}$$

where P_{vi} is the mass of reinforcement by unit of area in layer i in g/m², and Ψ_i is the content in mass of reinforcement in layer i .

z_i : distance, in mm, from the neutral fibre of layer i to an edge (regardless of direction):

$$z_i = z_{i-1} + \frac{t_{i-1} + t_i}{2}$$

E_i : Young's modulus of layer i , in N/mm², assumed to be known and experimentally verified. E_i is the lowest of the values in tension and compression.

The equivalent tensile elasticity modulus E_L , in N/mm², of the multi-layer laminate may be calculated by:

$$E_L = \frac{\sum E_i \cdot t_i}{\sum t_i}$$

The distance of the neutral fibre of the multi-layer laminate is, in mm:

$$V = \frac{\sum E_i \cdot t_i \cdot z_i}{\sum E_i \cdot t_i}, \text{ with regard to the edge of reference,}$$

$$V' = \sum t_i - V, \text{ with regard to the other edge.}$$

Distances d_i from the neutral fibre of each layer to the neutral fibre of the laminate are, in mm:

$$d_i = z_i - V$$

The flexural rigidity of the multi-layer laminate $[EI]$, by millimetre of width, in N.mm²/mm

$N \cdot mm^2/mm$ is

$$[EI] = \sum E_i \cdot \left(\frac{t_i^3}{12} + t_i \cdot d_i^2 \right)$$

The inertia of the multi-layer laminate, by millimetre of width, in mm⁴/mm, is:

$$[I] = \sum \left(\frac{t_i^3}{12} + t_i \cdot d_i^2 \right)$$

The theoretical bending breaking strength of the multi-layer laminate s_{br} , is, in N/mm²:

$$\sigma_{br} = k \cdot \frac{[EI]}{[I]} (1 - \mu_0)^2 \cdot 10^{-3}$$

where k is equal to:

- 17, for laminates using polyester resin,
- 25, for laminates using epoxy resin.

When the breaking strength of the laminate, given by mechanical tests as stipulated in [1.1.2], is greater than the theoretical calculated value σ_{br} , the breaking strength obtained from tests can be taken into account to increase the preceding value of σ_{br} .

c) Sandwich laminates

The inertia and flexural rigidity of sandwich laminates are to be calculated according to (d) and (e) above, taking into account the core as an elementary layer with its own characteristics (thickness and Young's modulus of the core material).

The theoretical bending breaking strength by bending of skins of the sandwich laminate is, in N/mm²

$$\sigma_{br} = k \cdot \frac{[EI]}{[I]} (1 - \mu_0)^2 \cdot 10^{-3}$$

where:

$[EI]$: flexural rigidity of the sandwich laminate, in N.mm²/mm

$N \cdot mm^2/mm$

$[I]$: inertia of the sandwich laminate, in mm⁴/mm,

μ_0 : vacuum content of skins,

k : coefficient equal to:

- 17,0 for skins using polyester resin,
- 25,0 for skins using epoxy resin,
- 12,5 for skins made of carbon reinforcements and epoxy resins.

When the breaking strength of the laminate by bending of skins, given by mechanical tests as required in [1.1.2], is greater than the theoretical calculated value σ_{br} , the breaking strength obtained from tests can be taken into account to increase the preceding value of σ_{br} .

The shear breaking of a sandwich laminate is to be considered in each individual case, considering the thickness and the shear breaking strength of the core material (see Sec 2, [6.3.3]).

d) Stiffeners

In general, the characteristics of the member considered as support only for the lamination of the stiffener are not to be taken into account for estimation of the mechanical characteristics of the stiffener.

Symbols are shown in Tab 2, where I_b is the width of the associated plating, defined in Tab 3.

To supplement the symbols defined in Sec 2, [6.3.4], the following elements are needed:

z_i : distance from the neutral fibres of the three elements, i.e. core, flange and associated plating (index i refers to each one of them), to the outer face of the associated plating, in mm

V : distance from the stiffener neutral fibre to the outer face of the associated plating, in mm:

$$V = \frac{\sum E_i \cdot S_i \cdot z_i}{\sum E_i \cdot S_i}$$

V' : distance from the stiffener neutral fibre to the outer face of the flange, in mm:

$$V' = H - V + t_s + t_b$$

d_i : distances from the neutral fibre of each element to the stiffener neutral fibre, in mm:

$$d_i = z_i - V$$

I_i : specific inertia of each element, in mm⁴.

The rigidity of a stiffener $[EI]$, in $N \cdot mm^2$ is:

$$[EI] = \left[\sum E_i \cdot (I_i + S_i \cdot d_i^2) \right]$$

The inertia of a stiffener $[I]$, in mm⁴, is:

$$[I] = \sum (I_i + S_i \cdot d_i^2)$$

The theoretical bending breaking strength of the stiffener σ_{br} , in N/mm², is:

$$\sigma_{br} = k \cdot \frac{[E]}{[I]} \cdot 10^{-3}$$

where k is equal to:

- 17, for stiffeners using polyester resin,
- 25, for stiffeners using epoxy resin.

Table 1

	Fibres				Resins			
	E Glass	Aramid	HS Carbon	HM Carbon	Polyester	Epoxy		
Mass density in g/cm ³	2,54	1,45	1,80	1,90	1,20	1,20		
Young's modulus, in N/mm ²	Parallel to fibres		73000	130000	230000	370000	3000	2600
	Perpendicular to fibres		73000	5400	15000	6000	-	-
Coulomb's modulus, in N/mm ²	30000	12000	50000	20000	-	-		
Poisson's ratio	0,25	0,35	0,35	0,35	0,316	0,40		

Table 2

Element	Width or height in mm	Thickness in mm	Modulus of elasticity in N/mm ²	Cross-Sectional area mm ²
Flange	I_s	t_s	E_s	$S_s = t_s \cdot I_s$
Core	H	t_a	E_a	$S_a = t_a \cdot H$
Associated plating	I_b	t_b	E_b	$S_b = t_b \cdot I_b$

Table 3

1		2
R_m = ultimate tensile strength	= $1278 G_c^2 - 510 G_c + 123$	75
E = tensile modulus of elasticity	= $(37 G_c - 4,75) 10^3$ (1)	6000
R_{mc} = ultimate compressive strength	= $150 G_c + 72$ (1)	115
E_c = compressive modulus of elasticity	= $(40 G_c - 6) 10^3$	4000
R_{mf} = ultimate flexural strength	= $(502 G_c^2 + 106,8)$ (2)	118
E_f = flexural modulus of elasticity	= $(33,4 G_c^2 + 2,2) 10^3$ (1)	5000
R_{mt} = ultimate shear strength	= $80 G_c + 38$	58
G = shear modulus of elasticity	= $(1,7 G_c + 2,24) 10^3$	2665
R_{mti} = ultimate interlaminar shear strength	= $22,5 - 17,5 G_c$	18
- Laminates with unidirectional reinforcements		
R_{mu} = ultimate tensile strength	= $1900 G_c^2 - 1500 G_c + 560$	304
E_u = tensile modulus of elasticity	= $(143 G_c^2 - 114 G_c + 42,7) 10^3$	23100
(1) Formula applicable for $G_c > 0,29$; for $G_c = 0,29 \div 0,25$, the following is required: $E \geq 6000$; $R_{mc} \geq 115$; $E_f \geq 5000$		
(2) For $G_c = 0,29 \div 0,25$, values of R_{mf} less than the values given by such formula are permitted down to a minimum of 85%; therefore, $R_{mf} = 118$ for $G_c = 0,25$		

2 Materials

2.1 Terminology

2.1.1

- a) Reinforced plastic: heterogeneous material consisting of a matrix of thermosetting resin with associated additives and of (generally glass) fibre reinforcements, produced as a laminate through moulding.
- b) Resins: of the unsaturated polyester type or possibly epoxide resins.
- c) Reinforcement of reinforced plastic: the fibres mentioned in a) for example in the form of mat, woven roving, cloth. The reinforcement may be termed:
 - homogeneous, when the fibres are made of the one material (for example glass) for the entire laminate;
 - promiscuous, when the fibres of some layers are made of one material and those of others of another;
 - hybrid, when the fibres of one or more layers are of two or more different materials.
- d) Single-skin laminate: a reinforced plastic material which is generally in the shape of a flat or curved plate, or moulded.
- e) Material composed of two single-skin laminates, structurally connected by the interposition of a core of light material.

2.2 Materials making up the laminates

2.2.1 General

All of the materials making up the laminates are to have properties suitable for hull construction in the opinion of the builder. Following examination of the relevant information received, Tasneef may, at its discretion, require specific checks of the laminates to be carried out.

2.2.2 Resins

Resins (see [2.1]) may be for laminating, i.e. form the matrix of laminates, or for surface coating (gel coat); the latter are to be compatible with the former and have mainly the purpose of protecting the laminate from external agents. Orthophthalic gel coat resins are not accepted.

2.2.3 Resin additives

Resin additives (catalysts, accelerators, fillers, colour pigments) are to be compatible with the resins and suitable for the curing process of the latter. Catalysts which initiate the curing process of the resin and accelerators which govern the gelling and setting times are to be such that the resin sets completely in cold conditions in the environmental conditions in which manufacture is carried out.

The inert fillers are not to:

- significantly alter the properties of the resin, with particular regard to the viscosity, and are to be uniformly distributed in the resin itself such that the laminates, in particular those of the fire-retarding type, have the minimum mechanical properties stated in these requirements;

- exceed 13% (including 3% of any thixotropic filler) by weight of the resin or, if less, the maximum amount recommended by the Manufacturer.

The colour pigments:

- are not to affect the polymerisation process of the resin;
- are to be added to the resin as a coloured paste and are not to exceed the maximum amount (in general 5%) recommended by the Manufacturer.

The thixotropic fillers of the resins for surface coating are not to exceed 3% by weight of the resin itself.

2.2.4 Glass fibre and associated products

Glass fibre of type E is to be employed for the following types of products:

M	: mat, continuous filament mat or chopped strand mat;
F_s	: rovings for chopping;
S	: woven roving;
S_u	: unidirectional woven roving;
T	: cloth;
C	: combined products, i.e. made up of more than one type, e.g. M+S.

2.2.5 Other types of fibres and associated products

The use of reinforcements made of aramid type fibres or carbon fibres or hybrid type fibres (e.g. cloth made of carbon and aramid type fibres) is allowed provided that the fibres and associated products comply with the "Rules for the type-approval of components of composite materials intended for hull construction".

Other types of fibres may be considered by Tasneef on a case-by-case basis.

2.3 Core materials for sandwich laminates

2.3.1 Such materials are to have the appropriate physical and mechanical properties and resistance to environmental agents for the intended use in accordance with the "Rules for the type-approval of components of composite materials intended for hull construction".

2.4 Type approval of materials

2.4.1 For the purposes of the type-approval, materials are to comply with the "Rules for the type-approval of components of composite materials intended for hull construction". As far as concerns fire resistance, materials are to be in accordance with specific standards recognised by Tasneef, in particular with the specific Tasneef requirements for the fire protection of reinforced plastic vessels.

2.5 Laminates with glass fibre reinforcements and associated characteristics

2.5.1 Terminology

γ_r	: density of the resin; standard value = 1,2 g/cm ³ ;
γ_v	: density (of the glass fibres; standard value = 2,56 g/cm ³ ;

- p** : mass per area of the reinforcement of a single layer of the laminate (g/m²);
- q** : total mass per area of a single layer (g/m²);
- g_c** : **p/q** content of glass reinforcement in the layer; the most frequent maximum values of **g_c** are the following, taking into account that reinforcements are to be "wet" by and compacted in the resin matrix: 0,34 for reinforcements in **M** or **F_s**; 0,5 for reinforcements in **S** or **T**;
- P** : total mass per area of the reinforcements in the laminate (g/m²);
- Q** : total mass per area of the laminate (g/m²), excluding the surface coating of resin;
- G_c** : **P/Q** = content of reinforcement in the laminate, between the minimum allowed value of 0,25 and approximately 0,5;
- t_i** : thickness of a single layer of the laminate, in mm, given by:
- $$t_i = 0,33p \left(\frac{2,56}{g_c} - 1,36 \right) \cdot 10^3$$
- t** : thickness of the laminate, in mm = sum of the **t_i** thicknesses.

2.5.2 Mechanical properties of laminates

The minimum mechanical properties of structural laminates of the hull, in N/mm², are given by the formulae in Tab 3 as a function of **G_c** of the laminate as defined in the previous paragraph. These values are based on the most frequently used laminates, i.e. those having **G_c** = 0,25÷0,34, approximately, in the case of reinforcements in only **M** or **F_s**, and **G_c** = 0,30÷0,50, approximately, in the case of reinforcements in different products, e.g. **M + S** or **M + S + T**. In column 2 of the table the values indicated are those given by the specific case of **G_c** = 0,25, the minimum allowed value of the content of glass reinforcement.

The minimum mechanical properties of the laminates, found in testing in accordance with the provisions of the "Rules for the type-approval of components of composite materials intended for hull construction", are to be not less than the values required above.

2.6 Laminates with reinforcement in fibres other than glass and associated characteristics

2.6.1 Laminates with reinforcements in fibres other than glass, described in [2.2], are to have mechanical properties that are in general greater than or at least equal to those given in Tab 3, promiscuous or hybrid reinforcements being employed if necessary for this purpose. Tasneef reserves the right to take into consideration laminates having certain properties lower than those given in the table, and will establish the procedure and criteria for approval.

2.7 Other materials

2.7.1 Materials, other than those dealt with above, employed for hull structural members, for example marine

plywood and possibly light alloys or steel, are to have suitable properties for the specific use in the opinion of Tasneef and are not to affect the polymerisation process of the resin.

The use of solid timber in place of marine plywood for the core of laminates is not recommended; however, where it is proposed, its use in each case will be the subject of special consideration by Tasneef.

2.8 Testing of hull laminates

2.8.1 Recognition of shipyards or workshops for hull construction

During the construction of the first hull and upon completion of the checks of the laminate manufacturing processes and of the suitability of the shipyard for hull construction as per Chapter 3, the following testing of the laminates is to be carried out according to the "Rules for the type-approval of components of composite materials intended for hull construction".

The relevant tests are to be carried out on specimens taken from samples of the laminate of the bottom of the hull and, if substantially different in composition and content of reinforcement, the laminate of the side and the deck, with measurement of the ultimate tensile strength and the ultimate flexural strength (N/mm²) together with the associated deflection (mm).

In the case of fire-resistant laminates, those tests required by Tasneef in accordance with the requirements for fire protection (see the specific requirements for the fire protection of reinforced plastic vessels) are to be carried out.

Subject to the outcome of the above-mentioned tests, Tasneef reserves the right to require further checks which, in the case of employment of materials that are not type approved, may also include testing of the materials making up the laminates.

2.8.2 Shipyards or workshops already recognised as suitable for hull construction

Shipyards or workshops already recognised as suitable for the construction of hulls in glass fibre reinforced plastic are generally to carry out tests of laminates in the following specific cases:

- use of values of the coefficients **K_{or}**, **K_{of}** and **K_{of}** less than those obtained by the formulae given in Sec 2, [7.5] and in Tab 3;

- use of special manufacturing processes for laminates, different from those for which the suitability was recognised;
- use of fibres in promiscuous or hybrid products;
- when doubts arise or in the event of disagreement.

The type and number of tests, to be performed on samples of laminates identical to those used for construction and manufactured with the same process, are stipulated in relation to the circumstances that determined the need for such testing and taking into account whether or not type approved materials have been used.

3 Hull construction processes and ship-yards or workshops

3.1 General

3.1.1 This Chapter states the general requirements for the construction of hand lay-up or spray lay-up laminates; processes of other types (e.g. by resin transfer, vacuum or pressurised moulding with **M** and continuous filaments) are to be recognised as suitable by Tasneef on an individual basis.

3.2 Moulds

3.2.1 Moulds for the production of laminates are to be constructed with a suitable material which does not affect the resin polymerisation and are to be adequately stiffened in order to maintain their shape and precision in form. They are also not to prevent the finished laminate from being released, thus avoiding cracks and deformations.

Moulds are to be thoroughly cleaned, dried and brought to the moulding shop temperature before being treated with the mould release agents, which are not to have an inhibiting effect on the gel coat resin.

During construction, provision is to be made to ensure satisfactory access such as to permit the proper carrying out of the laminating.

3.3 Laminating

3.3.1 The gel coat is to be applied by brush, roller or spraying device so as to form a uniform layer with a thickness of between 0,4 and 0,6 mm. Furthermore, it is not to be left exposed for longer than is recommended by the Manufacturer before the application of the first layer of reinforcement. A lightweight reinforcement is to be applied to the gel coat itself, is generally not to exceed a mass per area of 300 g/mm² and is to be applied through rolling so as to obtain a content of reinforcement, in weight, not exceeding approximately 0,3.

In the case of hand lay-up processing, the laminates are to be obtained with the layers of reinforcement laid in the sequence indicated in the plans and each layer is to be thoroughly "wet" in the resin matrix and compacted to give the required weight content.

The amount of resin laid "wet on wet" is to be limited to avoid excessive heat generation.

Laminating is to be carried out in such a sequence that the interval between the application of layers is within the limits recommended by the resin Manufacturer. Similarly, the time between the forming and bonding of structural members is to be kept within these limits; where this is not practicable, the surface of the laminate is to be treated with abrasive agents in order to obtain an adequate bond.

When laminating is interrupted so that the exposed resin gels, the first layer of reinforcement subsequently laid is to be of mat type.

Reinforcements are to be arranged so as to maintain continuity of strength throughout the laminate. Joints between

the various sections of reinforcement are to be overlapped and staggered throughout the thickness of the laminate.

In the case of simultaneous spray lay-up of resin and cut fibres, the following requirements are also to be complied with:

- before the use of the simultaneous lay-up system, the builder is to satisfy himself of the efficiency of the equipment and the competence of the operator;
- the use of this technique is limited to those parts of the structure to which sufficiently good access may be obtained so as to ensure satisfactory laminating;
- before use, the spray lay-up equipment is to be calibrated in such a way as to provide the required fibre content by weight; the spray gun is also to be calibrated, according to the Manufacturer's instruction manual, such as to obtain the required catalyst content, general spray conditions and appropriate length of cut fibres. Such length is generally to be not less than 35 mm for structural laminates, unless the mechanical properties are confirmed by tests; in any event, the length of glass fibres is to be not less than 25 mm;
- the calibration of the lay-up system is to be checked periodically during the operation;
- the uniformity of the lamination and fibre content is to be systematically checked during production.

The manufacturing process for sandwich type laminates is taken into consideration by Tasneef in relation to the materials, processes and equipment proposed by the builder, with particular regard to the core material and to its lay-up as well as to details of connections between prefabricated parts of the sandwich laminates themselves. The core materials are to be compatible with the resins of the surface laminates and suitable to obtain strong adhesion to the latter.

Attention is drawn, in particular, to the importance of ensuring the correct carrying out of joints between panels.

Insert plates of appropriate material to withstand the design loads are to be arranged in way of attachments. Such elements are to be suitably connected to the core material and the surface layer of the laminate.

3.4 Hardening and release of laminates

3.4.1 On completion of the laminating, the laminate is to be left in the mould for a period of time to allow the resin to harden before being removed. Such interval may vary, depending on the type of resin and the complexity of the laminate, but is to be at least 24 hours, unless a different period is recommended by the resin Manufacturer.

The hull, deck and large assemblies are to be adequately braced and supported for removal from the moulds as well as during the fitting-out period of the vessel.

After the release and before the application of any special post-hardening treatment, which is to be examined by Tasneef, the structures are to be stabilised in the moulding environment for the period of time recommended by the resin Manufacturer. In the absence of recommendations, this is to be at least 24 hours.

3.5 Defects in the laminates

3.5.1 The manufacturing processes of laminates are to be such as to avoid defects, in particular the following main types: surface cracks, surface or internal blistering due to the presence of air bubbles, cracks in the resin for surface coating, internal areas with non-impregnated fibres, surface corrugation, and surface areas without resin or with glass fibre reinforcements exposed to the external environment.

Any defects are to be eliminated by means of appropriate repair methods to the satisfaction of the Tasneef Surveyor.

3.6 Shipyards or workshops

3.6.1 General

Shipyards or workshops for hull construction are to be suitably equipped to provide the required working environment according to these requirements, which are to be complied with for the recognition of the shipyard or workshop as suitable for the construction of hulls in reinforced plastic. This suitability will be ascertained by Tasneef, the responsibility for implementing all measures necessary for the proper carrying out of construction being left to the shipyard.

When it appears from the tests carried out that the shipyard or workshop not only complies with the following requirements but also uses type approved materials (see [2.4]) and internal production control procedures which, in the opinion of Tasneef, are such as to ensure a consistent level of quality, it may obtain from Tasneef a special recognition of suitability for the construction of reinforced plastic hulls.

The risks of contamination of the materials are to be reduced as far as possible; separate zones are to be provided for storage and for manufacturing processes. Alternative arrangements of the same standard may be adopted.

3.6.2 Moulding shops

Where hand lay-up or spray lay-up processes are used for the manufacture of laminates, a temperature of between 16°C and 25°C is to be maintained in the moulding shop during the lay-up and polymerisation periods. Small variations in temperature may be allowed, at the discretion of the Tasneef Surveyor, always with due consideration being given to the resin Manufacturer's recommendations. Where moulding processes other than those mentioned above are used, the temperatures of the moulding shop are to be established accordingly.

The relative humidity of the moulding shop is to be kept as low as possible, preferably below 70%, and in any case lower than the limit recommended by the resin Manufacturer. Significant changes in humidity such as would lead to condensation on moulds and materials are to be avoided.

Instruments to measure the humidity and temperature are to be placed in sufficient number and in suitable positions. If necessary, due to the environmental conditions, an instrument capable of providing a continuous readout and record of the measured values may be required.

Ventilation systems are not to cause an excessive evaporation of the resin monomer and draughts are to be avoided.

The work areas are to be suitably illuminated. Precautions are to be taken to avoid effects on the polymerisation of the resin due to direct sunlight or artificial light.

3.6.3 Storage areas for materials

Resins are to be stored in dry, well-ventilated conditions at a temperature of between 10° and 20°C, or in conformity with the Manufacturer's recommendations. When the resins are stored outside the moulding shop, they are to be brought into the shop in due time to reach the working temperature required before being used.

Catalysts and accelerators are to be stored separately in clean, dry and well-ventilated conditions in accordance with the Manufacturer's recommendations.

Fillers and additives are to be stored in closed containers that are impervious to dust and humidity.

Reinforcements, e.g. in glass fibre, are to be stored in dust-free and dry conditions, in accordance with the Manufacturer's recommendations. When they are stored outside the cutting area, the reinforcements are to be brought into such area in due time so as to reach the temperature of the moulding shop before being used.

3.6.4 Identification and handling of materials

In the phases of reception and handling, the materials are not to suffer contamination or degradation and are at all times to bear adequate identification marks, including those relative to Tasneef type approval. Storage is to be so arranged such that the materials are used, whenever possible, in chronological order of receipt. Materials are not to be used after the Manufacturer's date of expiry, except when the Manufacturer has given the hull builder prior written consent.

SECTION 2

DESIGN LOADS AND HULL SCANTLING

1 Application

1.1

1.1.1 In general, the requirements from [2] to [6] apply. However, on the basis of the vessel's characteristics and the navigation notation required, Tasneef may accept structural strength checks carried out according to the requirements from [7] to [13].

1.1.2 On the basis of the vessel's characteristics and the navigation notation required, Tasneef may require structural strength checks based also on direct calculations.

2 Design acceleration

2.1 Vertical acceleration at LCG

2.1.1 The design vertical acceleration at LCG, a_{CG} (expressed in g), is defined by the Designer and corresponds to the average of the 1 per cent highest accelerations in the most severe sea conditions expected.

Generally, it is to be not less than:

$$a_{CG} = S \cdot \frac{V}{L^{0,5}}$$

where S is a parameter with values as indicated in Tab 1.

Lower S values, down to 80 per cent of tabular values, may be accepted, if justified, at TASNEEF's discretion. In exceptional cases greater reductions may be accepted, if justified, at TASNEEF's discretion, on the basis of model tests and full-scale measurements.

The sea areas referred to in Tab 1 are defined with reference to significant wave heights H_s which are exceeded for an average of not more than 10 percent of the year:

- Open-sea service: $H_s \geq 4,0$ m;
- Restricted open-sea service: $2,5 \text{ m} \leq H_s < 4,0$ m
- Moderate environment service: $0,5 \text{ m} < H_s < 2,5$ m
- Smooth sea service: $H_s \leq 0,5$ m.

If the design acceleration cannot be defined by the Designer, the a_{CG} value corresponding to the appropriate S value reported in Tab 1 will be assumed.

For limit operating conditions allowed for by design parameters, see [2.4].

For vessel the limit in a_{CG} adopted for the purpose of defining limit operating conditions is 2g.

2.2 Longitudinal distribution of vertical acceleration

2.2.1 The longitudinal distribution of vertical acceleration along the hull is given by:

$$a_v = k_v \cdot a_{CG}$$

where:

k_v : longitudinal distribution factor, defined in Fig 1, equal to the greater of $2x/L$ and 0,8, x being the distance, in m, from aft perpendicular to load point;

a_{CG} : design acceleration at LCG, see [2.1.1].

Variation of a_v in the transverse direction may generally be disregarded.

Table 1 (1/7/2021)

Type of service	S (1)	Restricted open sea	Moderate environment	Smooth sea
Pilot boat	$1,33 \cdot C_F$	0,40	0,30	Not applicable
Taxi	$0,65 \cdot C_F$	0,20	0,15	0,09

(1) For this condition, S is defined for each separate case, at the discretion of Tasneef, depending on the actual service area.

Figure 1

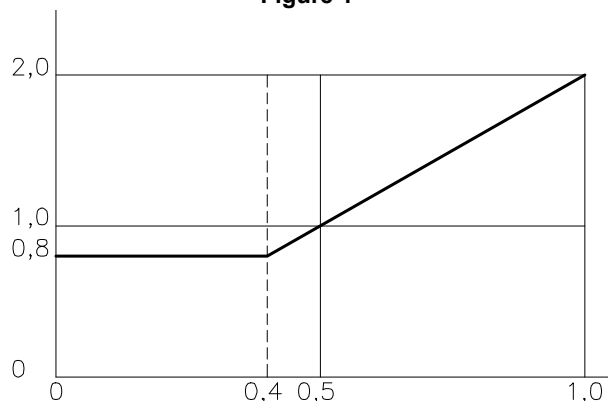

Table 2

Design category	Wind force (Beaufort scale)	Significant wave height (H 1/3, metres)
A - 'Ocean'	Exceeding 8	Exceeding 4
B - 'Offshore'	Up to and including 8	Up to and including 4
C - 'Inshore'	Up to and including 6	Up to and including 2
D - 'Sheltered waters'	Up to and including 4	Up to and including 0,5

2.3 Transverse acceleration

2.3.1 Transverse acceleration is defined on the basis of results of model tests and full-scale measurements, considering their characteristic value as specified in [2.4.1].

In the absence of such results, transverse acceleration, in g, at the calculation point of the vessel may be obtained from:

$$a_t = 2,5 \cdot \frac{H_{sl}}{L} \cdot \left[1 + 5 \cdot \left(1 + \frac{V/L^{0,5}}{6} \right)^2 \cdot \frac{r}{L} \right]$$

where:

H_{sl} : permissible significant wave height, defined in [2.4].

r : distance of the point from:

- 0,5 D, for monohull vessel
- waterline at draught T, for twin-hull vessel.

2.4 Assessment of limit operating conditions

2.4.1 "Limit operating conditions" in this paragraph are to be taken to mean sea states (characterized only by their significant wave heights) compatible with the design parameters of the vessel, i.e. the sea states in which the vessel may operate depending on its actual speed.

Limit operating conditions are used in this chapter only for the purpose of checking the strength of the structure.

Limit operating conditions, taken as a basis for classification, are indicated on the midship section drawing and are to be considered in defining the worst intended conditions and the critical design conditions.

The limit operating conditions can be :

- a) those indicated in Tab 2
- b) Statutory requirements by Flag Administration
- c) Direct calculation in case the point a) is not suitable and point b) is not available/defined

They are defined, at the discretion of Tasneef, on the basis of the results of model tests and full-scale measurements.

It is the Designer's responsibility to provide for a relation between the speed and the significant wave height which provides a maximum vertical acceleration less than the design value.

Model tests are to be carried out in irregular sea conditions with a significant wave height corresponding to the operating conditions of the vessel. The scale effect is to be accounted for with an appropriate margin of safety. The characteristic value of acceleration to be assumed corresponds to the average of the 1 per cent highest values obtained during tests. The duration of the tests is, as far as practicable, to be sufficient to guarantee that results are stationary.

Where model test results or full-scale measurements are not available, the formula contained in [2.4.2] may be used to define maximum speeds compatible with design acceleration, depending on sea states having a significant height H_s

Model tests or full measurements are to be provided, in any case, for vessel having an active support system. For vessel having a speed V such that $V/L^{0,5} < 3$, where model tests or full-scale measurements are not available the results provided by the formula indicated in [2.4.2] are to be supplemented, to TASNEEF's satisfaction, by data on the motion characteristics of vessel of type and dimensions similar to that under consideration.

On the basis of the formula indicated in [2.4.2], the limit sea state may be defined (characterised by its significant wave height H_{sl}), i.e. the sea state in which the vessel may operate at its maximum service speed. During its voyage, whenever the vessel encounters waves having a significant height greater than H_{sl} , it must reduce its speed.

It is assumed that, on the basis of weather forecast, the vessel does not encounter, within the time interval required for the voyage, sea states with significant heights, in metres, greater than the following:

At the discretion of Tasneef, a different value of H_{sm} may be assumed on the basis of considerations regarding the characteristics of the intended area of operation, the model test results and the hull structural strength exceeding the minimum level stated in this Sec 2.

For vessel with a particular shape or other characteristics, Tasneef reserves the right to require model tests or full-scale measurements to verify results obtained by the formulae.

Tasneef may require an accelerometer to be installed on the vessel, in general at LCG. The information given by the accelerometer is to be immediately readable at the wheel-house.

2.4.2

The significant wave height is related to the vessel's geometric and motion characteristics and to the vertical acceleration a_{CG} by the following formula:

$$\frac{H_s}{T} = 3555 \cdot \frac{C_B \cdot a_{CG}}{\left(\frac{V_x}{L_{0.5}}\right)^2 \cdot (50 - \alpha_{dCG}) \cdot \left(\frac{\tau}{16} + 0,75\right)} - 0,084 \cdot \frac{B_w}{T}$$

where:

- H_s : significant wave height, in m;
- α_{dCG} : deadrise angle, in degrees, at LCG, taken to be between 10° and 30°;
- τ : trim angle during navigation, in degrees, taken to be not less than 4°;
- V_x : vessel speed, in knots.

If V_x is replaced by the maximum service speed V of the vessel, the previous formula yields the significant height of the limit sea state, H_{sl} .

This formula may also be used to specify the permissible speed in a sea state characterised by a significant wave height equal to or greater than H_{sl} .

3 Overall loads

3.1 Twin-hull vessel transverse loads

3.1.1 General

For twin-hull vessel, the hull connecting structures are to be checked for load conditions specified in [3.1.2] and [3.1.3] below. These load conditions are to be considered as acting separately. Design moments and forces given in the following paragraphs are to be used unless other values are verified by model tests, full-scale measurements or any other information provided by the Designer (see [2.4.1], Requirements for model tests).

For vessel with structural arrangements that do not permit a realistic assessment of stress conditions based on simple models, the transverse loads are to be evaluated by means of direct calculations carried out in accordance with criteria specified in [5] or other criteria considered equivalent by Tasneef.

3.1.2 Transverse bending moment and shear force

The transverse bending moment M_{bt} , in KN · m, and shear force T_{bt} , in KN · m, are given by:

$$M_{bt} = \frac{\Delta \cdot b \cdot a_{CG} \cdot g}{5}$$

$$T_{bt} = \frac{\Delta \cdot a_{CG} \cdot g}{4}$$

where:

- b : transverse distance, in m, between the centres of the two hulls;
- a_{CG} : vertical acceleration at LCG, defined in [2.1].

3.1.3 Transverse torsional connecting moment

The twin-hull transverse torsional connecting moment, in kN · m, about a transverse axis is given by:

$$M_{tt} = 0,125 \cdot \Delta \cdot L \cdot a_{CG} \cdot g$$

where a_{CG} is the vertical acceleration at LCG, defined in [2.1], which need not to be taken greater than 1,0 g for this calculation.

3.2 Small waterplane area twin-hull (SWATH) vessel-Forces

3.2.1 Side beam force

The design beam side force, in kN, (see Fig 2) is given by:

$$F_Q = 12,5 \cdot T \cdot \Delta^{2/3} \cdot d \cdot L_S$$

where:

$$d = 1,55 - 0,75 \cdot \tanh\left(\frac{\Delta}{11000}\right)$$

$$L_S = 2,99 \cdot \tanh \lambda - 0,725$$

$$\lambda = \frac{0,137 \cdot A_{lat}}{T \cdot \Delta^{1/3}}$$

A_{lat} : lateral area, in m², projected on a vertical plane, of one hull with that part of strut or struts below waterline at draught T.

The lateral pressure, in kN/m², acting on one hull is given by:

$$p_Q = \frac{F_Q}{A_{lat}}$$

The distribution of the lateral force F_Q can be taken as constant over the effective length $L_e = A_{lat} / T$, in m. The constant lateral force per unit length, in kN/m, is thus given by:

$$q_Q = \frac{F_Q}{L_e}$$

Figure 2

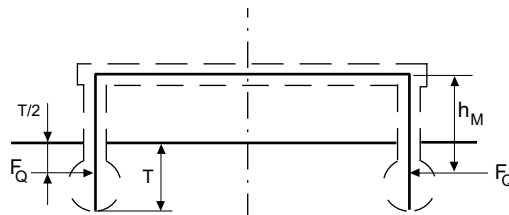

3.2.2 Bending moment

The corresponding design bending moment, in KN · m, is given by:

$$M_Q = h_M \cdot F_Q$$

h_M : half the draught T plus the distance from the waterline at draught T to the midpoint of the cross-deck structure (see Fig 3), in m.

Figure 3

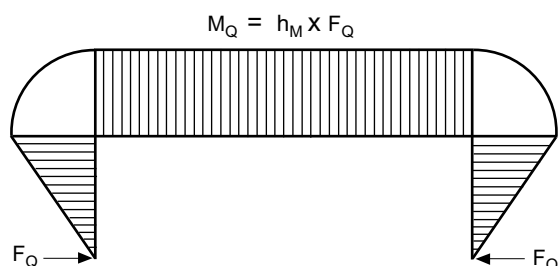

4 Local loads

4.1 Introduction

4.1.1 Design loads defined in this Article are to be used for the resistance checks provided for in [6] to obtain scantlings of structural elements of hull and deckhouses.

Such loads may be integrated or modified on the basis of the results of model tests or fullscale measurements. Model tests are to be carried out in irregular sea conditions with significant wave heights corresponding to the operating conditions of the vessel. The scale effect is to be accounted for by an appropriate margin of safety.

The characteristic value to be assumed is defined as the average of the 1 per cent highest values obtained during testing. The length of the test is, as far as practicable, to be sufficient to guarantee that statistical results are stationary.

4.2 Loads

4.2.1 General

The following loads are to be considered in determining scantlings of hull structures:

- impact pressures due to slamming, if expected to occur;
- sea pressures due to hydrostatic heads and wave loads;
- internal loads.

External pressure generally determines scantlings of side and bottom structures; internal loads generally determine scantlings of deck structures.

Where internal loads are caused by concentrated masses of significant magnitude (e.g. tanks, machinery), the capacity of the side and bottom structures to withstand such loads is to be verified according to criteria stipulated by Tasneef. In such cases, the inertial effects due to acceleration of the vessel are to be taken into account.

Such verification is to disregard the simultaneous presence of any external wave loads acting in the opposite direction to internal loads.

4.2.2 Load points

Pressure on panels and strength members may be considered uniform and equal to the pressure at the following load points:

- for panels: lower edge of the plate, for pressure due to hydrostatic head and wave load; geometrical centre of the panel, for impact pressure.

- for strength members: centre of the area supported by the element.

Where the pressure diagram shows cusps or discontinuities along the span of a strength member, a uniform value is to be taken on the basis of the weighted mean value of pressure calculated along the length.

4.3 Impact pressure on the bottom

4.3.1 If slamming is expected to occur, the impact pressure, kN/m², considered as acting on the bottom is not less than:

$$p_{sl} = 70 \cdot \frac{\Delta}{S_r} \cdot K_1 \cdot K_2 \cdot K_3 \cdot a_{CG}$$

where:

Δ : displacement, in tonnes (see [2.4]). For twin hull-vessel, Δ in the above formula is to be taken as half of the vessel displacement.

S_r : reference area, m²:

$$S_r = 0,7 \cdot \frac{\Delta}{T}$$

For twin-hull vessel, Δ in the above formula is to be taken as half the vessel displacement.

K_1 : longitudinal bottom impact pressure distribution factor (Fig 4):

$$0,5 + x/L, \text{ for } x/L < 0,5$$

$$1,0, \text{ for } 0,5 \leq x/L \leq 0,8$$

$$3,0 - 2,5 \cdot x/L, \text{ for } x/L > 0,8$$

where x distance, in m, from aft perpendicular to load point

K_2 : factor accounting for impact area

$$K_2 = 0,455 - 0,35 \cdot \frac{u^{0,75} - 1,7}{u^{0,75} + 1,7}$$

where

$$u : 100 \cdot \frac{s}{S_r}$$

s : area, m², supported by the element (plating, stiffener, floor or girder). For plating, the supported area is the spacing between the stiffeners multiplied by their span, without taking for the latter more than three times the spacing between the stiffeners.

where:

$$K_2 \geq 0,50, \text{ for plating}$$

$$K_2 \geq 0,45, \text{ for stiffeners}$$

$$K_2 \geq 0,35, \text{ for girders and floors.}$$

K_3 : $(70 - \alpha_d) / (70 - \alpha_{dCG})$

factor accounting for shape and deadrise of the hull, where α_{dCG} is the deadrise angle, in degrees, measured at LCG; values taken for α_d and α_{dCG} are to be between 10° and 30°.

a_{CG} : design vertical acceleration at LCG, defined in [2].

4.4 Impact pressure on bottom of cross-deck and internal sides (for twin-hull vessel)

4.4.1 Slamming on bottom of the cross-deck (wet deck) is assumed to occur if the distance, in m, between the waterline at draught T and the wet deck is less than Z_{wd} , where:

$$Z_{wd} : 0,05 \cdot L, \text{ if } L \leq 65 \text{ m}$$

$$Z_{wd} : 3,25 + 0,0214 \cdot (L - 65), \text{ if } L > 65 \text{ m}$$

In such a case, the impact pressure, in kN/m^2 , considered as acting on the wet deck is not less than:

$$p_{sl} = 3 \cdot K_2 \cdot K_{CD} \cdot V \cdot V_{sl} \cdot \left(1 - 0,85 \frac{H_a}{H_s}\right)$$

where:

K_2 : as defined in [4.3]

K_{CD} : longitudinal wet deck impact pressure distribution factor (Fig 5):

$$0,5 \cdot (1,0 - x/L) \quad \text{for } x/L < 0,2$$

$$0,4 \quad \text{for } 0,2 \leq x/L \leq 0,7$$

$$6,0 \cdot x/L - 3,8 \quad \text{for } 0,7 < x/L \leq 0,8$$

$$1,0 \quad \text{for } x/L > 0,8$$

x : distance, in m, from aft perpendicular to load point.

V : vessel's speed, in knots,

H_a : air gap, in m

V_{SL} : relative impact velocity, in m/s, given by:

$$V_{SL} = \frac{4 \cdot H_s}{L^{0.5}} + 1$$

H_s : significant wave height, in m.

If slamming is considered to occur on the wet deck, the impact pressure on the internal sides is obtained by interpolation between the pressure considered as acting on the bottom and the pressure P_{SL} at wet deck.

If the wet deck at a transverse section considered is not parallel to the design waterline the impact pressure P_{SL} will be considered in each separate case by Tasneef.

4.5 Sea pressures

4.5.1 The sea pressure, in kN/m^2 , considered as acting on the bottom and side shell is not less than p_{smin} , defined in Tab 3, or less than:

$$p_s = 10 \cdot \left[T + 0,75 \cdot S - \left(1 - 0,25 \cdot \frac{S}{T}\right) \cdot z \right], \text{ for } z \leq T$$

$$p_s = 10 \cdot (T + S - z), \text{ for } z > T$$

where:

z : vertical distance, in m, from the moulded base line to load point; z is to be taken positively upwards.

S : as given, in m, in Tab 3 with C_B taken not greater than 0,5

Between midship area and fore end ($0,5 < x/L < 0,9$), p_s varies in a linear way as follows:

$$p_s = p_{sFP} - (2,25 - 2,5 \cdot x/L) \cdot (p_{sFP} - p_{sM})$$

where p_{sFP} is the sea pressure at fore end and p_{sM} the sea pressure in the midship area.

Table 3

	S	$p_{s, min}$
$x/L \geq 0,9$	$T \leq 0,36 \cdot a_{CG} \cdot \frac{L^{0.5}}{C_B} \leq 3,5 \cdot T$	$20 \leq \frac{L+15}{2} \leq 35$
$x/L \leq 0,5$	$T \leq 0,60 \cdot a_{CG} \cdot L^{0.5} \leq 2,5 \cdot T$	$10 \leq \frac{L-5}{2} \leq 25$

4.6 Sea pressures on front walls of the hull

4.6.1 The pressure, kN/m^2 , considered as acting on front walls of the hull (in the case of a stepped main deck), not located at the fore end, is not less than

$$p_{sf} = 6 \cdot \left[1 + \frac{x_1}{2 \cdot L(C_B + 0,1)} \right] (1 + 0,045 \cdot L - 0,38 \cdot z_1)$$

where:

x_1 : distance, in m, from front walls to the midship perpendicular (for front walls aft of the midship perpendicular, $x_1 = 0$)

z_1 : distance, in m, from load point to waterline at draught T .

Where front walls are inclined backwards, the pressure calculated above can be reduced to

$$p_{sf} \cdot \sin^2 \alpha$$

where α is the angle in degrees between front wall and deck.

p_{sf} is not less than $6,5 + 0,06 L$.

For front walls located at the fore end, the pressure p_{sf} will be individually considered by Tasneef.

4.7 Sea pressures on deckhouses

4.7.1 The pressure, kN/m^2 , considered as acting on walls of deckhouses is not less than

$$p_{su} = K_{su} \left[1 + \frac{x_1}{2 \cdot L(C_B + 0,1)} \right] (1 + 0,045 \cdot L - 0,38 \cdot z_1)$$

where:

K_{su} : coefficient equal to:

- 6,0, for front walls of a deckhouse located directly on the main deck not at the fore end
- 5,0, for unprotected front walls of the second tier, not located at the fore end
- $1,5 + 3,5 \cdot \frac{b}{B}$ (with $3 \leq K_{su} < 5$)
for sides of deckhouses $b =$ breadth, in m, of considered deckhouse
- 3, for the other walls

x_1 : distance, in m, from front walls or from wall elements to the midship perpendicular (for front walls or side walls aft of the midship perpendicular, $x_1 = 0$)

z_1 : distance, in m, from load point to waterline at draught T.

The minimum values of p_{su} , in kN/m^2 , to be considered are:

- for the front wall of the lower tier:

$$p_{su} = 6,5 + 0,06 \cdot L$$

- for the sides and aft walls of the lower tier:

$$p_{su} = 4$$

- for the other walls or sides:

$$p_{su} = 3$$

For unprotected front walls located at the fore end, the pressure p_{su} will be individually considered by Tasneef.

4.8 Deck loads

4.8.1 General

The pressure, in kN/m^2 , considered as acting on decks is given by the formula

$$p_d = p \cdot (1 + 0)(,4 \cdot a_v)$$

where:

p : uniform pressure due to the load carried, in kN/m^2 . Minimum values are given in [4.8.2] to [4.8.6];

a_v : design vertical acceleration, defined in [2].

Where decks are intended to carry masses of significant magnitude, including vehicles, the concentrated loads transmitted to structures are given by the corresponding static loads multiplied by $(1 + 0)(,4 \cdot a_v)$.

Figure 4

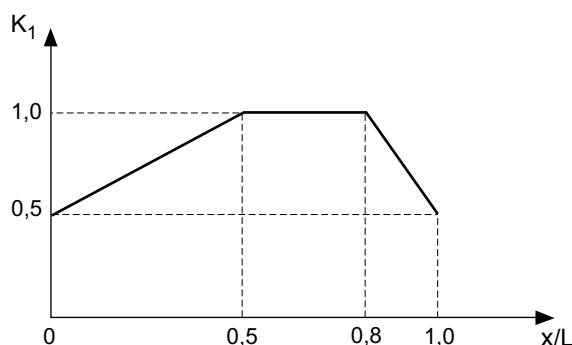
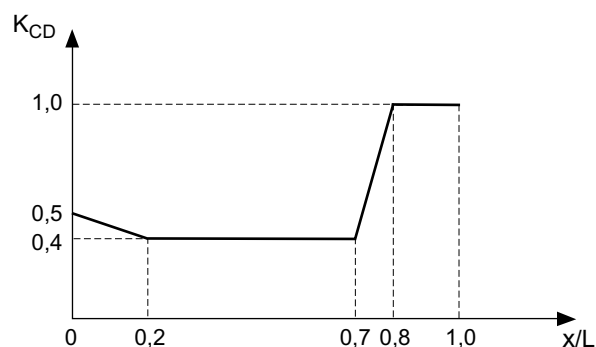

Figure 5



4.8.2 Weather decks and exposed areas

a) For weather decks and exposed areas without deck cargo if:

- $z_d \leq 2 \text{ m}$ $p = 6,0 \text{ kN/m}^2$
- $2 \text{ m} < z_d < 3 \text{ m}$ $p = 12 - 3 \cdot z_d \text{ kN/m}^2$
- $z_d \geq 3 \text{ m}$ $p = 3,0 \text{ kN/m}^2$

where z_d is the vertical distance, in m, from deck to waterline at draught T.

p can be reduced by 20% for primary supporting members and pillars under decks located at least 4 m above the waterline at draught T, excluding embarkation areas.

b) For weather decks and exposed areas with deck cargo if:

- $z_d \leq 2 \text{ m}$, $p = p_c + 2 \text{ kN/m}^2$, with $p_c \geq 4 \text{ kN/m}^2$
- $2 \text{ m} < z_d < 3 \text{ m}$, $p = p_c + 4 - z_d \text{ kN/m}^2$
with $p_c \geq 8 - 2 \cdot z_d \text{ kN/m}^2$
- $z_d \geq 3 \text{ m}$, $p = p_c + 1 \text{ kN/m}^2$
with $p_c \geq 2 \text{ kN/m}^2$

p_c : uniform pressure due to deck cargo load, in kN/m^2 , to be defined by the Designer with the limitations indicated above.

4.8.3 Shelter decks

They are decks which are not accessible to the passengers and which are not subjected to the sea pressures. Crew can access such decks with care and taking account of the admissible load, which is to be clearly indicated. Deck-houses protected by such decks may not have direct access to 'tween-deck below. For shelter decks

$$p = ,13 \text{ kN/m}^2$$

A lower value may be accepted, at the discretion of Tasneef, provided that such a value as well as the way of access to the deck are clearly specified by and agreed upon with the Owner.

4.8.4 Enclosed accommodation decks

a) For enclosed accommodation decks not carrying goods:

$$p = 3,0 \text{ kN/m}^2$$

p can be reduced by 20 per cent for primary supporting members and pillars under such decks.

b) For enclosed accommodation decks carrying goods:

$$p = p_c$$

The value of p_c is to be defined by the Designer, but taken as not less than 3,0 kN/m².

4.8.5 Enclosed cargo decks

For enclosed cargo decks other than decks carrying vehicles

$$p = p_c$$

where p_c is to be defined by the Designer, but taken as not less than 3,0 kN/m².

For enclosed cargo decks carrying vehicles, the loads are defined in [4.8.7].

4.8.6 Platforms of machinery spaces

For platforms of machinery spaces

$$p = 15,0 \text{ kN/m}^2$$

4.8.7 Enclosed decks carrying vehicles

The scantlings of the structure of enclosed decks carrying vehicles are to be determined by taking into account only the concentrated loads transmitted by the wheels of vehicles, except in the event of supplementary requirements from the Designer.

The scantlings under racking effects of the primary structure of decks carrying vehicles are to be the greater of the following cases:

- scantlings determined under concentrated loads transmitted by the wheels of vehicles,
- scantlings determined under a uniform load p_c taken not less than 2,5 kN/m². This value of p_c may be increased if the structural weight cannot be considered as negligible, in the opinion of Tasneef.

4.9 Pressures on tank structures

4.9.1 The pressure, in kN/m², considered as acting on tank structures is not less than the greater of

$$p_{t1} = 10 \cdot h_1 \cdot \rho \cdot (1 + 0,4 \cdot a_v) + 100 \cdot p_v$$

$$p_{t2} = 10 \cdot h_2$$

where:

- h_1 : distance, in m, from load point to tank top
- h_2 : distance, in m, from load point to top of overflow or to a point located 1,5 m above the tank top, whichever is greater
- ρ : liquid density, in t/m³ (1,0 t/m³ for water)
- p_v : setting pressure, in bars, of pressure relief valve, when fitted.

4.10 Pressures on subdivision bulkheads

4.10.1 The pressure, in kN/m², considered as acting on subdivision bulkheads is not less than

$$p_{sb} = 10 \cdot h_3$$

where:

- h_3 : distance, in m, from load point to bulkhead top.

5 Direct calculations

5.1 General

5.1.1 When deemed necessary by Tasneef, direct calculations of the hull structural scantlings are to be carried out, on the basis of the most advanced calculation techniques.

When performing direct calculations, the loads specified in [4] are to be applied. Where the scantlings of vessels of special design for which, in the opinion of Tasneef, these requirements are deemed inappropriate, loads calculated according to other criteria are to be adopted.

6 Scantlings

6.1 Introduction

6.1.1 This Article stipulates requirements for the scantlings of hull structures (plating, stiffeners, primary supporting members). The loads acting on such structures are to be calculated in accordance with the provisions of [4].

In general, for vessels with speed $V > 45$ knots, the scantlings of transverse structures are to be verified by direct calculations carried out.

For all other vessels, Tasneef may, at its discretion and as an alternative to the requirements of this Article, accept scantlings for transverse structures of the hull based on direct calculations.

6.2 Definitions

6.2.1 In addition to the definitions in Ch 1, Sec 1, the following is to be considered:

Superstructure - in this Article, a decked structure located above the uppermost continuous deck, extending from side to side of the vessel, or with the side plating not inboard of the shell plating by more than 4 per cent of the local breadth.

6.3 Structural scantlings - General

6.3.1 Main principles

a) General
Scantlings are given for the midship region and end regions. In intermediate regions, scantlings are to vary gradually from the midship region to the end regions.

Plating and stiffener scantlings are determined by the fact that the sum of stress due to local design loads and longitudinal bending of the hull (if applicable) is to be less than the corresponding allowable stress of the material, i.e. the breaking strength divided by a safety factor, defined below.

Scantlings may be increased where the structure is likely to be subjected to particular forces, for instance due to:

- very high speed,
- nature or uneven distribution of its loading, such as concentrated loads,
- particular conditions of operation, construction or design.

When design assumptions not covered by these Rules or unusual structural arrangements are provided, the proposed scantlings are to be backed by direct calculations carried out with an agreed method, and submitted to Tasneef for examination.

In such cases, the shipyard is to provide, to the satisfaction of Tasneef, all information needed to verify the calculation.

In addition to the cases explicitly foreseen by these Rules, subject to justifications submitted for examination, Tasneef may consider scantlings and structural arrangements, other than those derived from the application of these Rules, provided they take special account of:

- calculation method or a method for the determination of stresses offering a high level of accuracy; calculation data and all information necessary for their assessment are to be submitted to Tasneef,
- development of the applied techniques, the builder's practical experience and the means he uses to ensure an appropriate level of quality and building consistency,
- satisfactory behaviour in service of the type of hull structure concerned,
- particular loading cases.

b) Bottom - Side shell boundary for catamarans

For the structure of a catamaran, the inner walls of which are nearly vertical, the limit between bottom and side shell inside the two hulls is to be taken at the level of chine for external walls, as defined in Ch 1, Sec 1, [1.1.4].

c) Safety factors

The safety factor **SF** is equal to the ratio between the breaking strength (bending or shear) and the allowable stress for a material.

The safety factor to be considered for allowable bending stresses of plating and stiffeners is given in Tab 4.

The safety factor to be considered for allowable shear stress of core material of sandwiches and of web primary stiffener is given in Tab 5.

For vessels of unusual construction and/or with special service conditions, another value of the safety factor can be defined in accordance with the yard, which is to justify the new safety factor.

Figure 6

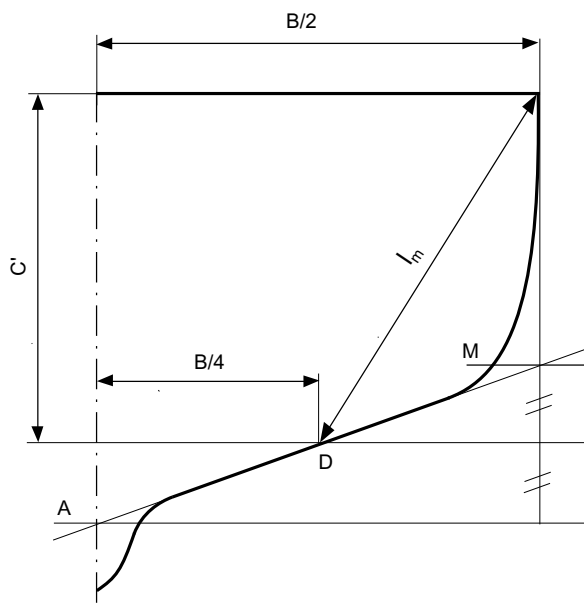

Table 4

	SF
General	6
Members subject to impact load	4,5
Transverse watertight bulkheads	5
Sides and ends of superstructures and deckhouses	4
Members subject to the test pressure p_e	4

Table 5

	SF	
Core of sandwich	General	3
	Sandwiches subject to impact load	2,5
Web of primary members	General	5
	Stiffeners subject to impact load	3,5
	Stiffeners on transverse watertight bulkhead	4
	Stiffeners of sides and ends of superstructures and deckhouses	3
	Stiffeners calculated with the test pressure p_e	3

6.3.2 Single skin laminates

a) General

The bending stress, in N/mm², of the laminate is to be multiplied by the following reduction factor **K_s**:

$$k_s = \mu_1 \cdot \alpha \cdot r_c^2$$

where:

- μ_1 : factor equal to:
 - 1 if $l \geq 2 \cdot s$
 - $1 - 1,5 \cdot \left(1 - \frac{l}{2 \cdot s}\right)^2$ if $s < l < 2 \cdot s$
 - 0,625 if $l \leq s$

where:

- l** : span of stiffener, in m
- s** : length, in m, as defined in Fig 7 or Fig 8
- α : $1 - 3 \cdot \left(\frac{a}{s}\right) \cdot \left(1 - \frac{a}{s}\right)$
 in the case of shell plating with ω stiffeners (see Fig 7) α is not to be taken less than 0,4; **a** is the length, in m, shown in Fig 7.
- r_c : $1 - 0,8 \cdot \frac{f}{s}$
 without being less than 0,85, where **f**, in m, is shown in Fig 8.

In the case of unstiffened shell plating with a large curvature, a relevant study of the stress is to be submitted to Tasneef for examination.

b) Scantlings of single skin laminates

The minimum thicknesses of the single skin laminate plates are not to be, as a rule, less than the following values:

- $1,5 \cdot (L + 10)^{0,5}$
for bottom and bilge plates,
- $1,25 \cdot (L + 10)^{0,5}$
for shell plating,
- $(L + 10)^{0,5}$
for other plating.

Lower values can be considered if a justification is sub-mitted to Tasneef.

The bending stress, in N/mm², due to the design pressure **p** (defined in [4]) is given by the formula:

$$\sigma_d = k_s \cdot \frac{V}{I} \cdot \frac{p \cdot s}{12} \cdot 10^3$$

where:

- V** : maximum distance of the neutral axis of the laminate, in mm, as defined in Sec 1, [1.1.3](b)
- [I]** : inertia of the laminate, by mm of width, in mm⁴/mm, as defined in Sec 1, [1.1.3](b).

The bending stress due to the design pressure σ_d is given by the following formula:

$$\sigma_d < \frac{\sigma_{br}}{SF}$$

where:

- σ_{br} : breaking bending strength of the laminate, as defined in Sec 1, [1.1.3](b),
- SF** : safety factor, as defined in [6.3.1].

The bending stress σ_{de} , in N/mm², calculated for the test pressure **p_e** is to be:

$$\sigma_{de} < \frac{\sigma_{br}}{SF}$$

The bending deflection, due to design pressure **p** (see [4]), of a sandwich laminate between stiffeners is not to be greater than about 1% of the stiffener spacing. The total deflection, in mm, of a sandwich laminate, fixed on its edges, is given by the formula:

$$f = \frac{\mu_2}{384} \cdot \frac{p \cdot s^4}{[EI]} \cdot 10^9$$

where:

- [EI]** : rigidity of the sandwich laminate, for 1 mm width, in N · mm²/mm
- μ_2 : 1, for $l \geq 2 \cdot s$
 $1 - 2,1 \cdot \left(1 - \frac{l}{2 \cdot s}\right)^2$ for $s < l < 2 \cdot s$
 0,475, for $l \leq s$

Figure 7

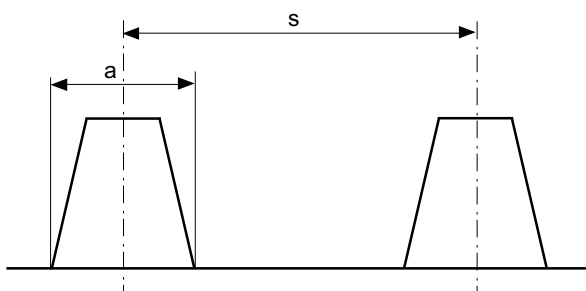
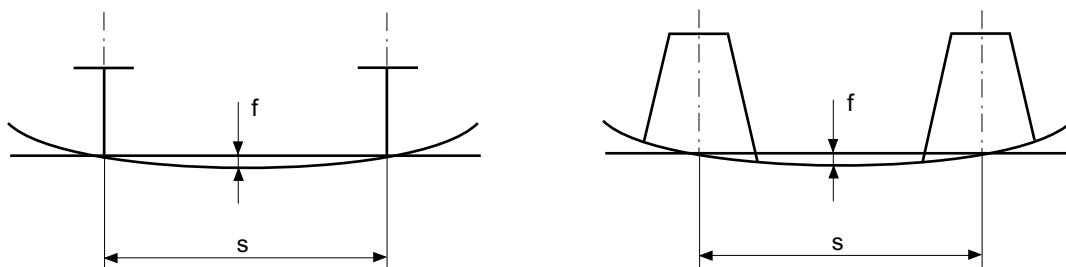

Figure 8



6.3.3 Sandwich laminates

a) General

See [6.3.2] (a).

b) Scantlings of sandwich laminates

The minimum thicknesses of each skin of sandwich laminate plates are in general not to be less than the following values:

- $0,6 \cdot (L + 10)^{0,5}$
 , for bottom and bilge plates,
- $0,5 \cdot (L + 10)^{0,5}$
 , for shell plating,
- $0,4 \cdot (L + 10)^{0,5}$
 , for other plating.

Lower values can be considered if a justification is submitted to Tasneef.

The bending stress, in N/mm², due to the design pressure **p** (defined in [4]) is equal to:

$$\sigma_d = k_s \cdot \frac{V}{[I]} \cdot \frac{p \cdot s^2}{12} \cdot 10^3$$

where:

V : maximum distance of the neutral axis of the sandwich, in mm, as defined in Sec 1, [1.1.3](c).

[I] : inertia of the sandwich, by mm width, in mm⁴/mm, as defined in Sec 1, [1.1.3] (c).

The bending stress due to design pressure σ_d is to be such that:

$$\sigma_d < \frac{\sigma_{br}}{SF}$$

where:

σ_d : breaking bending strength of the sandwich, as defined in Sec 1, [1.1.3] (c),

SF : Safety factor, as defined in [6.3.1].

The bending stress σ_{de} , in N/mm², calculated for the test pressure **p_e** is to be such that:

$$\sigma_{de} < \frac{\sigma_{br}}{SF}$$

The shear stress, in N/mm², due to the design pressure **p**, is to be:

$$\tau_d = \frac{p \cdot s}{2 \cdot t_a}$$

where **t_a** is the thickness of the core, in mm.

The shear stress due to the design pressure is to be such that:

$$\tau_d < \frac{\tau_{br}}{SF}$$

where:

τ_{br} : shear breaking strength of the core material, in N/mm²,

SF : safety factor, as defined in [6.3.1].

The sum of the bending and shear deflections, due to the design pressure **p** (see [4]), of a sandwich laminate between stiffeners is not to be greater than about 1% of the stiffener

spacing. The total deflection, in mm, of a sandwich laminate, fixed on its edges, is given by the formula:

$$f = \frac{\mu_2}{384} \cdot \frac{p \cdot s^4}{[EI]} \cdot 10^9 + \frac{\mu_3}{8} \cdot \frac{p \cdot s^2}{t_a \cdot G} \cdot 10^3$$

where:

[EI] : rigidity of the sandwich laminate, for 1 mm width, in N · mm²/mm, as defined in Sec 1, [1.1.3] (c)

t_a : core thickness, in mm

G : shear modulus of the core material, in N/mm²

μ_2 : factor defined in [6.3.2] (b)

μ_3 : 1, for $l \geq 2 \cdot s$

$$1 - 1,8 \cdot \left(1 - \frac{l}{2 \cdot s}\right)^2, \text{ for } s < l < 2 \cdot s$$

$$0,550, \text{ for } l \leq s$$

6.3.4 Stiffeners

a) General

The Rule values of stiffener stresses take account of the width **l_b** of the attached plating, defined below:

- for primary stiffeners, **l_b** is the smaller of the two values:

s or $0,2 l$, stiffener **L**,

s or $0,2 l + a$, stiffener Ω ,

where **a** is defined in [6.3.2],

- for ordinary stiffeners, **l_b** is equal to the spacing **s** between stiffeners.

Cutouts for the passage of ordinary stiffeners are to be as small as possible. As a rule, the depth of cutouts is not to be greater than half the web height of the primary stiffener.

b) Scantlings

The bending stress σ_d , in N/mm², due to the design pressure **p** (defined in [4]) is given by the formula:

$$\sigma_d = \varepsilon \cdot \frac{p \cdot s \cdot l^2}{12} \cdot \frac{V}{[I]} \cdot 10^6$$

where:

ε : 1, if the stiffener is fixed at its ends, 1,5, in other cases.

V : distance from the stiffener neutral axis to the flange, in mm, as defined in Sec 1, [1.1.3] (d)

[I] : inertia of the stiffener, in mm⁴, as defined in Sec 1, [1.1.3] (d).

The bending stress due to the design pressure σ_d , is to be:

$$\sigma_d < \frac{\sigma_{br}}{SF}$$

where:

σ_{br} : breaking bending strength of the stiffener, as defined in [1.3.3 b].

SF : Safety factor, as defined in [6.3.1].

The shear stress, in N/mm², due to the design pressure **p** (defined in [4]) is given by the formula:

$$\tau_d < \frac{p \cdot s \cdot l}{2 \cdot S_a} \cdot 10^3$$

where S_a is the total web cross-sectional area, in mm².

For primary stiffeners, the shear stress due to the design pressure is to be:

$$\tau_d < \frac{\tau_{br}}{SF}$$

where:

τ_{br} : shear breaking strength, in N/mm², of the laminate forming the web of the primary stiffener. If a precise value of τ_{br} obtained from tests or other agreed method is not available, τ_{br} is equal to 60 N/mm²,

SF : Safety factor, as defined in [6.3.1].

The bending stress σ_{de} , in N/mm², calculated for the test pressure p_e is to be such that:

$$\sigma_{de} < \frac{\sigma_{br}}{SF}$$

For primary stiffeners the shear stress τ_{de} , in N/mm², calculated for the testing pressure p_e , is to be:

$$\tau_{de} < \frac{\tau_{br}}{SF}$$

6.4 Bottom structure

6.4.1 Application

The requirements of this item [6.4] apply to single or double-bottom structures with longitudinal or transverse framing.

The requirements of this article are to be used for the scantlings of the main structural members located between the keel and the chine, as defined in Ch 1, Sec 1, [1.1.4] and also [6.3.1] (b) for catamarans.

The requirements of this article apply also to structural members of the vault of catamarans.

6.4.2 General arrangements

In general, a continuous centreline girder is to be provided over the full length of the vessel.

In the engine room additional girders are to be fitted in order to provide sufficient structural strength. Unless otherwise specified, the shipyard is to submit the supporting structure to the engine builder for agreement on rigidity and arrangements.

Floors are to be continuous between the centreline keelson and the bilge.

A floor or a girder is to be provided under each line of pillars.

Main engines and thrust blocks are to be secured to the hull structure by seatings with adequate strength to withstand forces transmitted by the propulsive installation.

When solid ballast is fitted, it is to be securely positioned. If necessary, intermediate floors may be fitted for the purpose.

For each floor or keelson web, the height thickness ratio is not to exceed 25.

Provision is to be made for the free passage of water from all parts of the bottom to the suctions, taking into account the pumping rate required.

6.4.3 Plating scantlings

Plating scantlings are to be calculated in accordance with [6.3.2] and [6.3.3].

The width of the keel plate, in m, is not to be less than 0,6 + 0,01 L.

6.4.4 Stiffener scantlings

Stiffener scantlings are to be calculated in accordance with [6.3.4].

For the scantlings of a bottom girder, its span l is to be measured:

- between transverse bulkheads, if the keelson can be considered as a support, i.e if its height is at least 1,5 times the height of the floors in the centreline, and its moment at least twice the moment of the floors in the centreline,
- between floors, if the keelson is intercostal, its height not exceeding the floor height.

For the scantlings of a floor, its span l is to be measured:

- between side shell plates, if the bottom is flat and supporting bottom girders or longitudinal bulkheads do not exist,
- between side shell plating and keel, in the case of pronounced sections if supporting bottom girders or longitudinal bulkheads do not exist,
- between side shell plating and keelson, side shell plating and bulkhead, or bulkhead and bulkhead, if longitudinal bulkheads or keelson exist, the scantlings and the span of which are such that they can be considered as a support.

For vessels with a dead rise of floors, the floor span is to be measured from the vessel centreline, when the angle of the dead rise of floor is greater than:

- 20° in the case of built-in floor at side,
- 10° in the case of supported floor at side.

This being so, the floor moment is to be calculated in accordance with [6.4.4], with $\epsilon = 1,1$.

When the primary structure is made of a frame of crossed stiffeners with equivalent scantlings, a calculation of the totality of the stiffeners, taking relative stiffnesses into account, is to be submitted.

6.4.5 Double-bottom structure

In general, the height of the double bottom is not to be less than $0,1 \cdot L^{0,5}$.

Side girders are to be fitted. In general, their spacing is not to exceed 4,2 m.

6.5 Side shell structure

6.5.1 Application

The requirements of this Article apply to transversely or longitudinally framed side shell structure.

The requirements of this article are to be used for the scantlings of the main structural members located between the chine, as defined in Ch 1, Sec 1, [1.1.4], and the highest continuous deck.

The requirements of this article apply to structural members of inner walls of catamarans (see [6.3.1] (b)).

6.5.2 General arrangements

In the case of longitudinal framing, the web frames are to be located in way of floors.

In the case of transverse framing, the section modulus of the web frames located in the engine room is to be not less than 4 times that of adjacent frames, and the cross-sectional area of these web frames is to be not less than twice that of adjacent frames.

In the case of transverse framing, frames are to be fitted at each frame space. The scantlings of main and 'tween deck frames are not to be less than those of frames located immediately above.

In general, stringers are required if the span of main and 'tween deck frames is greater than 4 m.

Web frames are to be fitted in way of beams at hatch ends.

The flanges of stringers and web frames are to be connected if necessary.

6.5.3 Plating scantlings

Plating scantlings are to be calculated in accordance with [6.3.2] and [6.3.3].

The width of the sheerstrake, in m, is not to be less than:

$$b = 0,715 + 0,425 \cdot \frac{L}{100}$$

Unless otherwise specified, the thickness of the sheerstrake is not to be less than that of the adjacent side shell plating.

The thickness of the sheerstrake is to be increased by 40%, in way of breaks in long superstructures occurring within the midship 0,5 L, over a length of about one sixth of the vessel breadth on each side of the superstructure end.

The thickness of the sheerstrake is to be increased by 30%, in way of breaks in long superstructures occurring outside the midship 0,5 L, over a length of about one sixth of the vessel breadth on each side of the superstructure end.

The thickness of the sheerstrake is to be increased by 15%, in way of breaks in short superstructures occurring within the midship 0,5 L, over a length of about one sixth of the vessel breadth on each side of the superstructure end.

6.5.4 Stiffener scantlings

Stiffeners scantlings are to be calculated in accordance with [6.3.4].

For the scantlings of a stringer, its span I is to be measured:

- between transverse bulkheads if the stringer can be considered as a support or if there is no vertical web,

- between vertical webs if the stringer is intercostal and cannot be considered as a support between transverse bulkheads.

For the scantlings of a vertical web frame, its span I is to be measured:

- 'tween decks or between deck and bottom, if there are no stringers or if stringers are intercostal,
- between deck and stringer, bottom and stringer or between stringers if stringers can be considered as a support between transverse bulkheads.

When the primary structure is made of a frame of crossed stiffeners with equivalent scantlings, a calculation of the totality of stiffeners, taking relative stiffnesses into account, is to be submitted.

6.6 Deck structure

6.6.1 Application

The requirements of this article apply to transversely or longitudinally framed deck structure.

The requirements of this article are to be used for the scantlings of the main structural members of the strength deck, lower and platform decks, accommodation decks and the decks of superstructures and deckhouses.

6.6.2 General arrangements

In the case of longitudinal framing, the beams are to be located in way of the vertical web frames of side shell.

In the case of transverse framing, the beams are to be, in general, fitted at every frame, in line with side shell stiffeners.

In the case of a vertical break for the strength deck, the continuity of strength is to be ensured by a tapered structure of the two decks within a length between 2 and 5 frame spaces.

The transverse strength of vessels with large deck openings is to be considered in each case.

In the area of openings, the continuity of strength of longitudinal hatch coamings is to be ensured by underdeck girders.

Hatch girders and reinforced beams are to be fitted in way of hatch openings.

The flanges of girders and reinforced beams are to be connected, if necessary.

In the case of concentrated loads on decks (e.g. pillars, winches, davits), direct calculations are to be carried out taking into account simultaneous design pressure and concentrated loads.

6.6.3 Plating scantlings

Plating scantlings are to be calculated in accordance with [6.3.2] and [6.3.3].

The width of the stringer plate, in m, is not to be less than:

$$b = 0,005 \cdot (L + 70)$$

The thickness of the stringer plate is to be increased by 40%, in way of breaks of long superstructures occurring within the midship 0,5 L, over a length of about one sixth of the vessel breadth on each side of the superstructure end.

The thickness of the stringer plate is to be increased by 30%, in way of breaks of long superstructures occurring outside the midship $0,5 L$, over a length of about one sixth of the vessel breadth on each side of the superstructure end.

The thickness of the stringer plate is to be increased by 15%, in way of breaks of short superstructures occurring within the midship $0,6 L$, over a length of about one sixth of the vessel breadth on each side of the superstructure end.

6.6.4 Stiffener scantlings

Stiffeners scantlings are to be calculated in accordance with [6.3.4].

For the scantlings of a girder, its span I is to be measured:

- between transverse bulkheads, if the girder can be considered as a support, i.e if its height is at least 1,5 times the height of the floors in the centreline, and its moment at least twice the moment of the floors in the centreline
- between deck beams, if the girder is intercostal and used to prevent tripping instability of deck beams.

For the scantlings of a deck beam, its span I is to be measured:

- between side shell plates, if there are no girders which can be considered as a support or if there are no longitudinal bulkheads
- between side shell plating and bulkhead or girder, or between bulkheads or girders if there are longitudinal bulkheads or girders, the scantlings and span of which are such that they can be considered as a support.

Hatch beams and hatch girders are to be of reinforced scantlings, to take the interrupted stiffeners into account.

The scantlings of hatch beams and girders are not to be less than those obtained in accordance with [6.3.4], changing s to take into account the effective supported areas.

When the primary structure is made of a frame of crossed stiffeners with equivalent scantlings, a calculation of the totality of stiffeners taking relative stiffnesses into account is to be submitted.

6.6.5 Deck covers

The scantlings of deck cover plating are to be determined in accordance with [6.3.2] and [6.3.3].

The scantlings of the deck cover stiffeners are to be calculated in accordance with [6.3.4], the span I of the stiffener being measured:

- between the two edges of the cover, if the stiffener can be considered as a support for this dimension,
- between perpendicular stiffeners, if the stiffener is considered as intercostal.

In the case of deck cover with a frame of crossed stiffeners with equivalent scantlings, a calculation of the totality of stiffeners taking into account the relative stiffnesses is to be submitted.

6.7 Bulkhead structures

6.7.1 Application

The requirements of this article are to be used for the scantlings of the main structural members of:

- transverse or longitudinal watertight bulkheads,
- transverse or longitudinal tank bulkheads,
- transverse or longitudinal wash bulkheads,
- cofferdam bulkheads,
- shaft tunnel bulkheads.

6.7.2 General provisions

The scantlings of tank bulkheads which are also Rule bulkheads are not to be less than those required for a watertight bulkhead.

Where bulkheads do not extend up to the uppermost continuous deck (such as the after peak bulkhead), suitable strengthening is to be provided in the extension of the bulkhead.

Bulkheads are to be stiffened in way of deck girders.

Floors are to be fitted in the double bottom, in way of plane transverse bulkheads.

The scantlings of stiffeners on the horizontal part of stepped bulkheads are to be calculated as for beams.

Where vertical stiffeners are cut in way of watertight doors, reinforced stiffeners are to be fitted on each side of the door and suitably overlapped; crossbars are to be provided to support the cut-off stiffeners.

Provision is to be made to avoid the buckling of large accommodation bulkheads without stiffeners.

6.7.3 Plating scantlings

Plating scantlings are to be calculated in accordance with [6.3.2] and [6.3.3].

6.7.4 Stiffener scantlings

Stiffeners scantlings are to be calculated in accordance with [6.3.4].

For the scantlings of a stringer, its span I is to be measured:

- between side shell plates, between longitudinal bulkheads or between side shell plating and longitudinal bulkhead, for stringers of transverse bulkheads considered as a support,
- between transverse bulkheads, for stringers of longitudinal bulkheads considered as a support,
- between vertical webs, for stringers whose scantlings are such that they cannot be considered as a support.

For the scantlings of a vertical web, its span I is to be measured:

- between decks or between deck and bottom if the vertical web can be considered as a support,
- between horizontal stiffeners if scantlings of the vertical web are such that it cannot be considered as a support.

When the primary structure is made of a frame of crossed stiffeners with equivalent scantlings, a calculation of the totality of stiffeners taking relative stiffnesses into account is to be submitted.

6.7.5 Watertight doors

The strength of a watertight door is not to be less than that of the adjacent bulkhead.

In the calculation of the scantlings of stiffeners of watertight door, stiffeners are to be considered as supported at ends.

6.8 Superstructure and deckhouse structures

6.8.1 Application

The requirements of this article apply to the structure of superstructures and deckhouses framed transversely and longitudinally.

6.8.2 General provisions

Reduction in scantlings may be granted for:

- deckhouses not protecting openings in the freeboard and superstructure decks,
- deckhouses located above the third tier.

These reductions are to be individually examined by Tasneef.

Ends of superstructures and deckhouses are to be efficiently supported by bulkheads, pillars or other equivalent system.

Where hatchways are fitted close to the ends of superstructures, additional strengthening may be required.

All openings cut in the sides or decks of superstructures and deckhouses are to be stiffened and have well rounded corners. Continuous stiffeners are to be fitted below and above doors or similar openings. Where necessary, compensation for large openings may be required.

Side plating at the ends of superstructures is to be tapered into the bulwark or sheerstrake of the strength deck. Where a raised deck is fitted, this arrangement is to extend over a three-frame space.

Access openings cut in sides of enclosed superstructures are to be fitted with watertight doors, permanently attached.

The structure and attachment system of these doors are to be arranged so that the strength remains equivalent to that of a non-pierced bulkhead.

Securing devices which ensure weathertightness are to include tight gaskets, clamping dogs or other similar appliances, and to be permanently attached to the bulkheads and doors. These doors are to be arranged for operation from both sides.

As a rule, the spacing of stiffeners on sides of superstructures and deckhouses is to be the same as that of beams on supporting decks.

Partial bulkheads or webs are to be arranged to support the sides and ends of superstructures and deckhouses. Scantlings of these web frames are to be individually considered.

Sides of deckhouses are to be strengthened in way of lifeboats and the top plating is to be reinforced in way of lifeboat davits.

Special attention is to be paid to the transfer of vertical loads between decks.

6.8.3 Plating scantlings

Plating scantlings are to be calculated in accordance with [6.3.2] and [6.3.3].

When the superstructure deck is the strength deck, the scantlings of the sides of superstructures are to be determined as for the side shell plates.

The plating thickness of sides of long superstructures is to be increased by 25% over a length of about one sixth of the vessel breadth on each end of the superstructure.

6.8.4 Stiffener scantlings

Stiffener scantlings are to be calculated in accordance with [6.3.4].

Scantlings of side stiffeners of superstructures and deckhouses need not exceed those of side stiffeners of the tier immediately below, based on the same span and spacing.

Tasneef reserves the right to require a special examination of superstructure frames:

- where the decks at ends of the considered frame are not stiffened in the same way,
- where the frame span exceeds 4 m,
- for passenger vessels.

In the case of a superstructure or deckhouse contributing to longitudinal strength, the vertical stiffeners between windows on the sides are to be individually examined.

6.9 Principles of building

6.9.1 Definitions

The stiffeners with the lower spacing are defined in this chapter as ordinary stiffeners.

Depending on the direction of ordinary stiffeners, a structure is made of one of the following systems:

- longitudinal framing,
- transverse framing.

Ordinary stiffeners are supported by structural members, defined as primary stiffeners, such as:

- keelsons or floors,
- stringers or web frames,
- reinforced beams or deck stringers.

6.9.2 General provisions

The purpose of this item [6.9.2] is to give some structural details which may be recommended. However, they do not constitute a requirement; different details may be proposed by builders and agreed upon by Tasneef, provided that builders give justifications, to be defined in each special case.

Arrangements are to be made to ensure the continuity of longitudinal strength:

- in areas with large change of strength,
- at connections of ordinary and primary stiffeners.

Arrangements are to be made to ensure the continuity of transverse strength in way of connections between hulls of catamarans and axial structure.

Structure discontinuities and rigid points are to be avoided; when the strength of a structure element is reduced by the presence of an attachment or an opening, proper compensation is to be provided.

Openings are to be avoided in highly stressed areas, in particular at ends of primary stiffeners, and for webs of primary stiffeners in way of pillars.

If necessary, the shape of openings is to be designed to reduce stress concentration.

In any case, the corners of openings are to be rounded.

Connections of the various parts of a hull, as well as attachment of reinforcing parts or hull accessories, can be made by moulding on the spot, by bonding separately moulded, or by mechanical connections.

Bulkheads and other important reinforcing elements are to be connected to the adjacent structure by corner joints (see Fig 9) on both sides, or equivalent joint.

The mass per m² of the corner joints is to be at least 50% of the mass of the lighter of the two elements to be fitted, and at least 900 g/m² of mat or its equivalent.

The width of the layers of the corner joints is to be worked out according to the principle given in Fig 9.

The connection of the various parts of the hull, as well as connection of reinforcing members to the hull, can be made by adhesives, subject to special examination by Tasneef.

6.9.3 Plates

The edges of the reinforcements of one layer are not to be juxtaposed but to overlap by at least 50 mm; these overlaps are to be offset between various successive layers.

Prefabricated laminates are fitted by overlapping the layers, preferably with chamfering of edges to be connected.

The thickness at the joint is to be at least 15% higher than the usual thickness.

Changes of thickness for a single-skin laminate are to be made as gradually as possible and over a width which is, in general, not to be less than thirty times the difference in thickness, as shown in Fig 10.

The connection between a single-skin laminate and a sandwich laminate is to be carried out as gradually as possible over a width which is, in general, not to be less than three times the thickness of the sandwich core, as shown in Fig 11.

a) Deck-side shell connection

This connection is to be designed both for the bending stress shown in Fig 12, caused by vertical loads on deck and horizontal loads of seawater, and for the shear stress caused by the longitudinal bending.

In general, the connection is to avoid possible loosening due to local bending, and ensure longitudinal continuity. Its thickness is to be sufficient to keep shear stresses acceptable.

Fig 13 to Fig 16 give examples of deck-side shell connections.

b) Bulkhead-hull connection

In some cases, this connection is needed to distribute the local load due to the bulkhead over a sufficient length of hull. Fig 17 and Fig 18 give possible solutions. The scantlings of bonding angles are determined according to the loads acting upon the connections.

The builder is to pay special attention to connections between bulkheads of integrated tanks and structural members.

c) Passages through hull

Passages of metal elements through the hull, especially at the level of the rudder stock, shaft brackets, shaft-line, etc., are to be strongly built, in particular when subjected to alternating loads.

Passages through hull should be reinforced by means of a plate and counterplate connected to each other.

d) Passages through watertight bulkheads

The continuous omega or rectangle stiffeners at a passage through a watertight bulkhead are to be watertight in way of the bulkhead.

e) Openings in deck

The corners of deck openings are to be rounded in order to reduce local stress concentrations as much as possible, and the thickness of the deck is to be increased to maintain the stress at a level similar to the mean stress on the deck.

The reinforcement is to be made from a material identical to that of the deck.

6.9.4 Stiffeners

Primary stiffeners are to ensure structural continuity.

Abrupt changes in web height, flange breadth and cross-sectional area of web and flange are to be avoided.

In general, at the intersection of two stiffeners of unequal sizes (longitudinals with web-frames, floors, beams or frames with stringers, girders or keelsons), the smallest stiffeners (longitudinals or frames) are to be continuous, and the connection between the elements is to be made by corner joints according to the principles defined in [6.9.2].

Fig 19 to Fig 21 give various examples of stiffeners.

Connections between stiffeners are to ensure good structural continuity. In particular, the connection between deck beam and frame is to be ensured by means of a flanged bracket. However, some types of connections without bracket may be accepted, provided that loads are light enough. In this case, stiffeners are to be considered as supported at their ends.

6.9.5 Pillars

Connections between metal pillars subject to tensile loads and the laminate structure are to be designed to avoid tearing between laminate and pillars.

Connections between metal pillars subject to compressive loads and the laminate structure are to be carried out by means of intermediate metal plates. The welding of the pillar to the metal plate is to be carried out before fitting of the plate on board vessel.

Fig 21 gives the principle for connection between the structure and pillars subject to compressive loads.

6.9.6 Engine seating

The engine seating is to be fitted on special girders suitably positioned between floors, which locally ensure sufficient strength in relation to pressure and weight loads.

Fig 23 gives an example of possible seating.

Figure 9

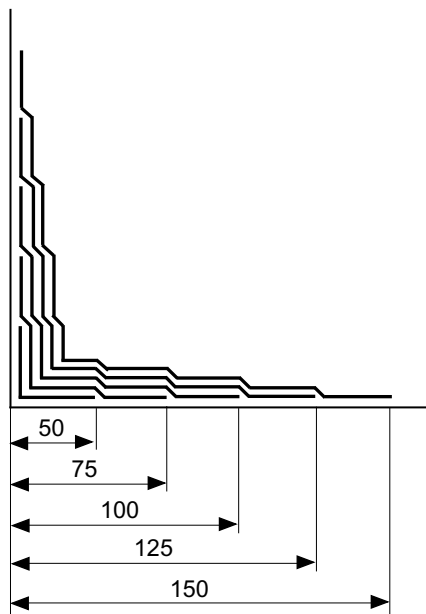

Figure 10

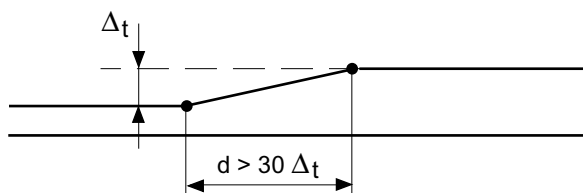

Figure 11

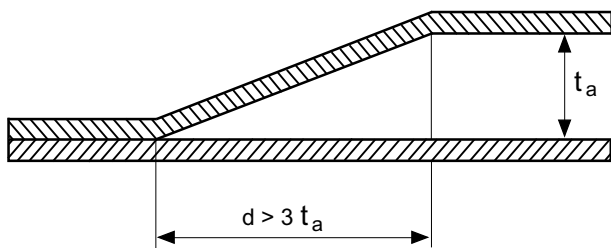

Figure 12

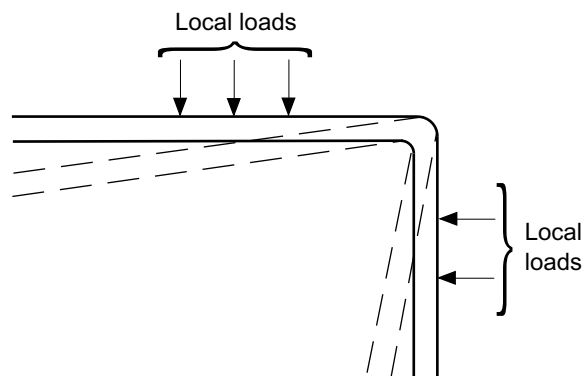

Figure 13

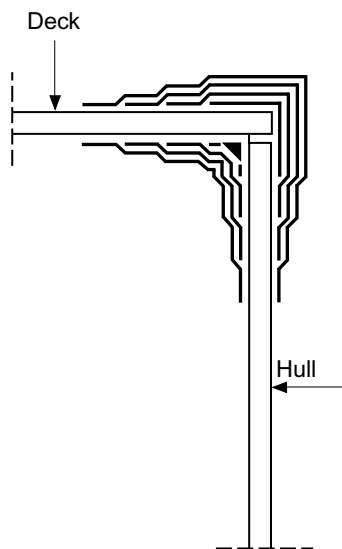

Figure 14

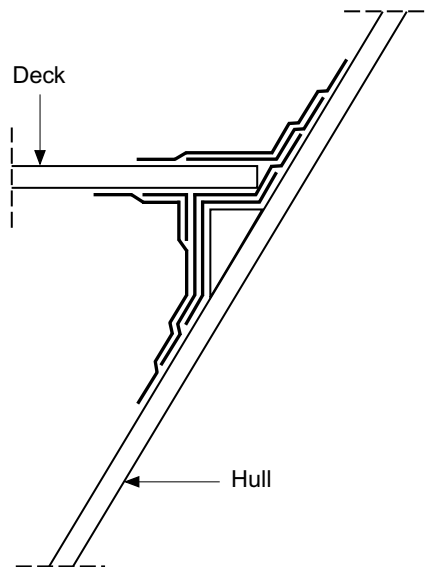

Figure 15

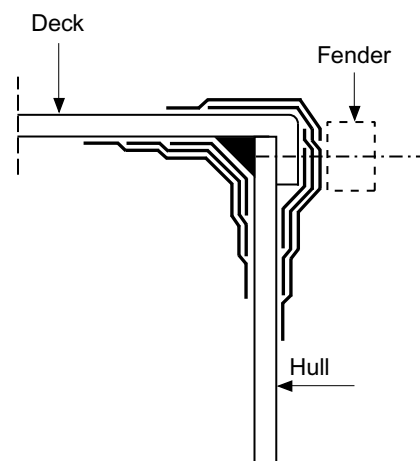

Figure 16

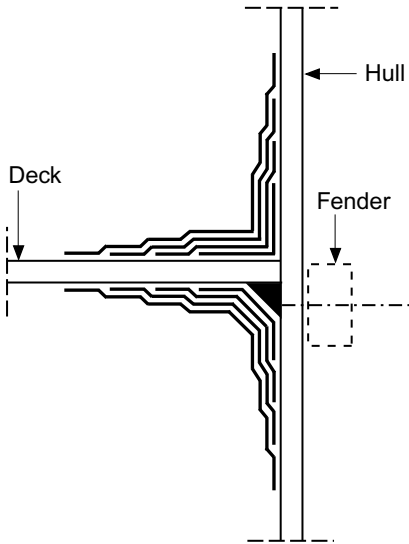

Figure 19

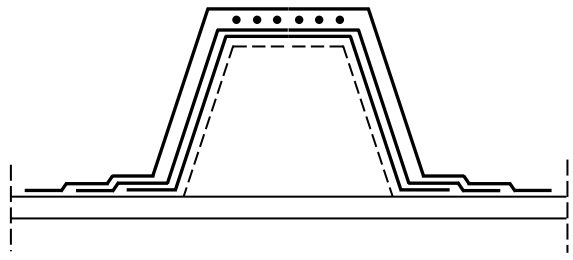

Figure 20

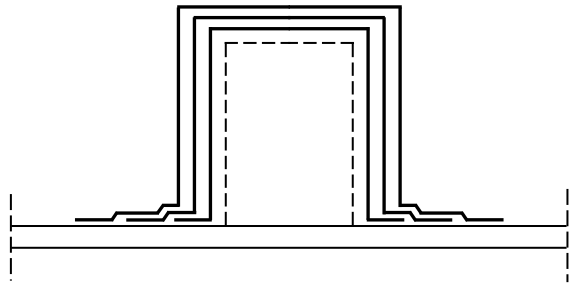

Figure 17

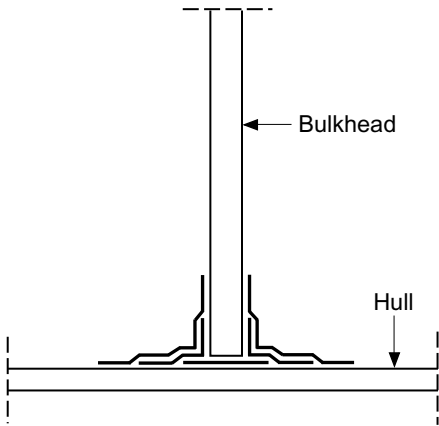

Figure 21

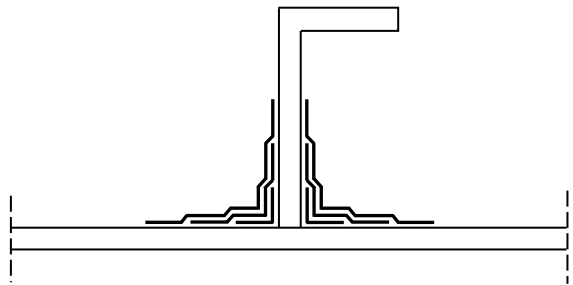

Figure 18

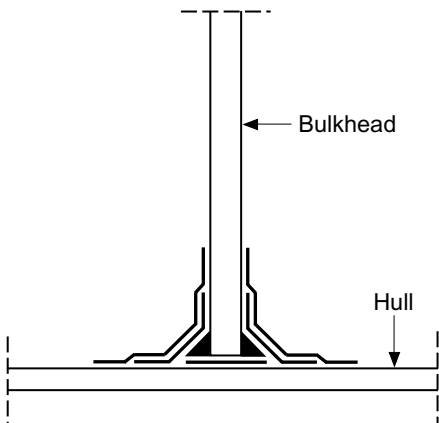

Figure 22

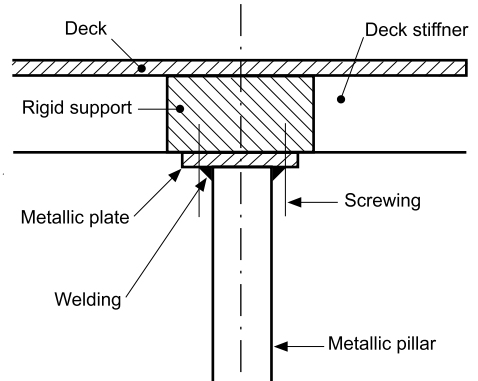
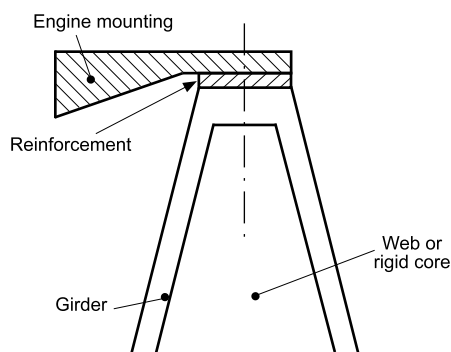

Figure 23



7 General requirements for structural scantlings

7.1 Terminology

7.1.1 The following definitions and symbols are valid throughout these Rules, except where otherwise stated.

s : spacing, in metres, of ordinary stiffeners of plating; in the case of sections of Ω type, the value of **s** is given, for the calculation of the plating thicknesses, by the distance between the inner edges of the two adjacent sections;

s_r : reference spacing of ordinary stiffeners given, in metres, by:

$$s_r = (2,3L + 460) \cdot 10^{-3}$$

where **L** = length of the hull defined in Ch 1, Sec 1, [1.1.4]

S : conventional overall scantling span of a girder, in metres, to be assumed equal to the distance between the supporting elements at the ends of the beam;

b : actual width, in metres, of the load-bearing plating;

Z : Rule section modulus, in cm³, of a girder in association with a width of plating having conventional breadth equal to **s** or, for primary supporting members, equal to **b**;

K₀, **K_{of}**, **K'_{of}**: coefficients relative to materials, given in [7.5];

K_{V1}, **K_{V2}**, **K'_{V3}** and **K_{V4}**: coefficients for "high speed" hulls, given in [7.7].

7.2 Size and distribution of hull structural scantlings, type of structure and structural continuity

7.2.1 Hull structural scantlings and service of the vessel

The structural scantlings established in these Rules may be reduced in the case of vessels classed for restricted service, at TASNEEF's discretion.

7.2.2 Distribution of structural scantlings

The hull scantlings required in these Rules are to extend for the entire length of the hull without reductions at the fore

and aft ends, unless otherwise stated in specific cases below.

7.2.3 Type of structure

Hull structure is conventionally divided into the following types:

- longitudinal, when the ordinary stiffeners consist mainly of longitudinals on the bottom, sides and weather deck, supported by transverse webs constituted by floors, side frames and deck frames or by equivalent transverse bulkheads. The spacing of webs is generally required to be not greater than approximately 2 m (except for high speed hulls, for which see [7.7]) or, for hulls having $L > 6$ m, not greater than 2,5 m;
- transverse, when the ordinary stiffeners consist mainly of floors, side frames and deck beams.

Transverse structure is permitted, as a rule, for hulls which are not high speed hulls and which are of limited length, i.e. **L** not exceeding 20 m.

7.2.4 Structural continuity

In designing the vessel, special attention is to be given in order to prevent any structural discontinuity; to this end, the variation in scantlings and structures, such as in way of openings in strength decks, is to be gradual.

7.3 Longitudinal strength

7.3.1 The structural scantlings in these Rules are intended as being adequate in case of openings in decks of limited breadth as specified below.

Therefore, the calculation of the section modulus, in cm³, of the midship section with respect to the bottom, **W_f**, and with respect to the deck, **W_p**, is requested only for the following hulls, unless it is deemed necessary by Tasneef also in other cases:

- hulls with openings with breadth greater than 0,3 of the local breadth of the deck
- hulls having unconventional form.

7.4 Direct calculations

7.4.1 Direct calculations of the hull structural scantlings are to be carried out, on the basis of the most modern technology, in those cases deemed necessary by Tasneef.

With regard to the loads acting on the structures and to the load conditions, the relevant requirements of Part B, Chapter 5 of the Rules concerning ordinary vessels are generally adopted, except in the case of vessels of special design for which, in the opinion of Tasneef, these Rules are inappropriate and require modification or for which other criteria are to be adopted.

7.5 Coefficients for the scantlings of structures relative to the mechanical properties of laminates

7.5.1 The values of the coefficients **K₀** and **K_{of}** that appear in the formulae of the hull structural scantlings in these

Rules refer to single-skin laminates with glass fibre reinforcements and are given by:

$$K_0 = 75)(R_m$$

$$K_{of} = \sqrt{118} \sqrt{R_{mf}}$$

where R_m and R_{mf} are, in N/mm², the values of the ultimate tensile and flexural strengths given by the formulae in Sec 1, Tab 3 or, for tested laminates, the values obtained in the tests.

Therefore, in the case of laminates having $G_c = 0,25$ (minimum permitted) $K_0 = K_{of} = 1$ is to be assumed.

The values K_0 and K_{of} are to be assumed not less than 0,5 and 0,7, except for specific cases assessed by Tasneef on the basis of the tests performed.

The values of K_0 and K_{of} of single-skin laminates with reinforcements in fibres other than glass, or with promiscuous or hybrid reinforcements, are determined using the formulae above with:

R_m : the lower of the ultimate tensile strength and the ultimate compressive strength, in N/mm²

R_{mf} : ultimate flexural strength, in N/mm².

For the thickness of surface sandwich laminates the requirements stated above apply, as appropriate, taking however the coefficient $K'_{of} = \sqrt{75} \sqrt{R_m}$ instead of K_{of} .

7.6 Mass of reinforcement fibres in laminates

7.6.1 The mass per area, in kg/m², requested for the glass fibres in a laminate is obtained from the following formula:

$$P_r = \frac{3,07}{(2,56/G_c) - 1,36} \cdot t$$

where G_c is the content of fibres in the laminate, defined in Sec 1, [2.5.1], and t is the thickness, in mm, of the laminate itself prescribed in the requirements for structural scantlings given later in this Section. Therefore, P_r is the Rule value of the mass per area of the reinforcements.

For laminates with reinforcements in fibres other than glass, or with promiscuous or hybrid reinforcements, the mass per area of the reinforcements and the thickness t of the laminates are to be equal or equivalent to those measured on the panels used for mechanical tests.

7.7 Coefficients for scantlings and type of structure of high speed hulls

7.7.1 "High speed hulls" is intended to mean those propelled by an engine for which the ratio

$$\alpha = V/\sqrt{L}$$

is greater than 3,6 where V is the maximum design speed, in knots, and L is the length of the hull, in metres, on the load waterline, defined in Ch 1, Sec 1, [1.1.4]. The most commonly found design characteristics of such hulls are given below **by way of example for the purpose of information only**

L : 10 ÷ 30 m

D : (0,15 ÷ 0,18)L

B : (1,6 ÷ 2,2)D

T : (0,3 ÷ 0,55)D

α : 3,6° ÷ 11°

$V \leq 35$ knots

B_c : (0,7 ÷ 0,8) B = breadth, in metres, between the chines in the transverse section located 0,65 L from the aft perpendicular

β : 12° ÷ 18° = dead rise of the bottom in way of B_c

Δ_p : (0,11L² - 11) + 24 = design displacement at the full load, in tonnes.

The hull structure is, as a rule, to be longitudinal with spacing of longitudinals and side webs limited to a maximum of 1,5 s_r and 2 s_r , where s_r = reference frame spacing.

The coefficients which appear in the following structural scantling formulae are:

K_{v1} , relative to the thickness of bottom plating;

K_{v2} , relative to the thickness of side plating;

K_{v3} , relative to the modulus Z of the bottom longitudinals and floors;

K_{v4} , relative to the modulus Z of the side longitudinals and side webs.

The values of these coefficients are given by the following formulae but, in any event, are not to be taken less than 1:

$$K_{v1} : 0,34\sqrt{\alpha} + 0,35$$

$$K_{v2} : (0,024\alpha + 0,91)(1,018 - 0,0027L)$$

$$K_{v3} : 0,36\alpha - 0,3$$

$$K_{v4} : K_{v2}$$

The above formulae are deemed appropriate up to values of $V = 35$ knots, and $\alpha = 11^\circ$. This value of α corresponds to the Froude number 1,8 given by the ratio $\sqrt{L/g}$

where

g : gravity acceleration = 9,81 m/s²;

V : speed, in m/s;

L : length as defined above.

For greater values of V (as a rule not exceeding 31 m/s (60 knots)), the above coefficients are to be considered only for guidance.

For hulls having $\alpha < 3,6^\circ$ the coefficients defined above are all assumed equal to 1.

7.8 Structures with sandwich construction

7.8.1 General requirements

The scantlings of sandwich type structures laid down in [7.8.2] are established using a criterion of equivalence with respect to those of structures with single-skin laminates.

Any other criteria may, however, be taken into consideration by Tasneef in each case on the basis of direct calculations of the structural scantlings.

7.8.2 Scantlings of sandwich laminates

The thickness of both surface laminates of the sandwich is, as a rule, to be not less than 0,6 of the thickness of the single-skin laminate calculated with the relevant formula given in the following chapters, using $s/s_r = 1$ and $K'_{of} = 1$. Each of the thicknesses is then to be corrected by multiplying by K'_{of}

(see [7.5]), but is to be taken, as a rule, not less than 2,5 mm.

The minimum section modulus, in cm^3/cm , of a section of 1 cm width of the sandwich is given by:

$$Z_s = \frac{Z}{s_r}$$

where:

Z : section modulus, in cm^3 , of the reinforcement (presuming the associated strip of plating to be single-skin laminate), to be obtained from the relevant formula given in the following chapters, assuming $s = s_r$ and span equal to the minimum distance between the structural members supporting the sandwich. The relevant absolute Rule minimum value is not to be taken into account in the calculation of **Z**.

The minimum section modulus, **W**₁ or **W**₂, in cm^3/cm , of a given sandwich is to be $\geq Z_s$.

The minimum value of the flexural modulus of stiffness **EJ**, in $\text{N/mm}^2 \cdot \text{cm}^4/\text{cm}$, of a sandwich is not prescribed; however, for guidance, it is suggested that the value of **J**, in cm^4/cm , should not be less than that obtained from the following relation:

$$J = 2,4 + Z_s^3$$

The ultimate shear strength **R**_t, in N/mm^2 , of the core material of a sandwich is to be at least equal to 0,4 and in such case the height **h**, in cm, of the sandwich is given by:

$$h = 7,5(\sqrt{Z_s} - 0,45)$$

where:

h : $t_c + 0,5(t_1 + t_2)$, t_c being the height of the core of the sandwich, in cm, and t_1 and t_2 being the thickness of each of the two surface sandwich laminates, in cm. The absolute minimum value of **h** is, as a rule, to be not less than 0,8 cm.

Z_s : section modulus defined above.

The value of **h** is reduced linearly for core materials which have $R_t > 0,4 \text{ N/mm}^2$.

8 Keel; stem and sternpost or sternframe (transom); rudder horn; propeller shaft brackets

8.1 Keel

8.1.1 The keel is to have width not less than 0,05 **L** and thickness t_{ch} , in mm, at least equal to the greatest of the following values:

- thickness of the bottom plating of the hull;
- $t_{ch} = 1,4 t_1$ where t_1 = thickness of the bottom plating given in [9.2] (using $s = s_r$ in the formula) in the case of a U-shaped keel or of a bottom with a dead rise $\geq 12^\circ$ or of a plate keel with centre vertical girder;
- $t_{ch} = 2 t_1$ in the case of a plate keel, or with a dead rise less than 12° , without centre vertical girder.

The thickness t_{ch} is to be gradually tapered to the thickness of the bottom and, in the case of hulls having a U-shaped keel, t_{ch} is to extend transversally to the bottom plating with adequate tapering.

When the hull is prefabricated in two halves, the keel joint is to be carried out with adequate overlapping of the layers of reinforcement on both sides of the bottom.

Figure 24

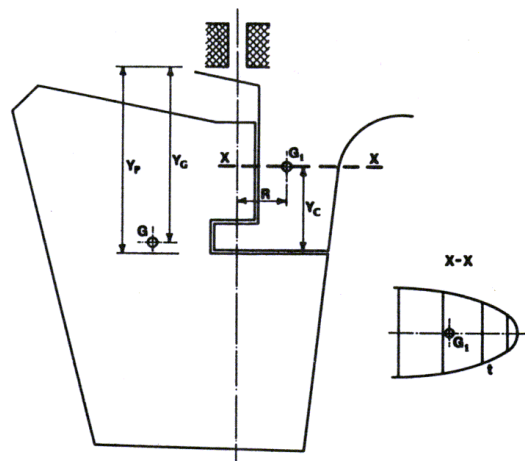

G : centroid of the rudder

G₁ : centroid of the sect. **X - X** of the rudder horn

8.2 Stem and sternpost or sternframe (transom)

8.2.1 The stem and the sternpost are to have thickness not less than:

- t_{ch} , extending up to the full load waterline;
- t_1 (given by the formula in [9.3], using $s = s_r$ and $K_{V1} = 1$) extending up to the above-mentioned waterline as far as the deck or edge

The thickness t_s , in mm, of the transom is to be not less than the value t_2 for the side plating of the hull given in [9.3] using $K_{V2} = 1$. When outboard or stern drive engines are fitted, the thickness t_s is to be suitably increased or, alternatively, a structure with double plating and a core in plywood may be used such that, in the opinion of the Designer, the strength of the transom is adequate in relation to the weight and output of the engines.

8.3 Rudder horn

8.3.1 Rudder horns of semi-spade rudders are to be adequately dimensioned in relation to the force acting on the pintle.

For rudders with one pintle only, this condition is generally satisfied when the generic section **X - X** has:

- section modulus **Z** with respect to the longitudinal axis, in cm^3 ,
- area **a** of the figure bounded by the rudder's external contour, in cm^2 ,
- average thickness **t** of the rudder shell, in cm, such as to satisfy the following relation:

$$\frac{0,1ApY_g}{Y_p} \left(\frac{Y_c}{Z} + \sqrt{\frac{Y_c^2}{Z^2} + \frac{R^2}{t^2 a^2}} \right) \leq 0,15$$

where:

- A** : the total rudder area, in m²
p : external pressure on the rudder, in kN/m², given by:
p = 9,8 K₀ (V+3)² x 10⁻³ where:
K : 8,75 for rudders inside the propeller jet
 7,35 for rudders outside the propeller jet
V : speed of the vessel, in knots
R : distance from the centroid of the section considered of the rudder horn to the centreline of the rudder stock, in cm
Y_g, Y_p, Y_c: distances, in cm, shown in Fig 24.

The connection of the rudder horn to the hull will be subject to special consideration by Tasneef on a case-by-case basis.

8.4 Propeller shaft brackets

8.4.1 For double arm or single arm propeller shaft brackets made of steel or other metal, the requirements in Part B, Chapter 10, Sec 3 of the Rules apply.

9 Bottom, side and deck plating

9.1 General

9.1.1 The thickness of external and deck plating given by the requirements in this Chapter is to be increased as far as necessary such as to ensure the hull longitudinal strength, when prescribed (see [7.3]).

9.2 Bottom plating

9.2.1

The thickness **t₁** of bottom plating, in mm, is to be not less than:

$$t_1 = 3,9 \frac{S}{s_r} \sqrt{L-3} K_{of} K_{V1}$$

or less than the thickness of side plating or, in any case, less than 3 mm, where:

- L** : length of the hull defined in Ch 1, Sec 1, [1.1.4];
s and **s_r** : spacing defined in [7.1];
K_{of} : coefficient relative to the mechanical properties of the laminate of bottom plating, defined in [7.5];
K_{V1} : coefficient relative to high speed hulls defined in [7.7]

The thickness of the bottom is to extend transversally up to not less than 150 mm above the full load waterline and, in any case, beyond the chine in the case of chine units.

9.3 Side and sheerstrake plating

9.3.1 The thickness **t₂** of side and sheerstrake plating, in mm, is to be not less than:

$$t_2 = 3 \frac{S}{s_r} \sqrt{L-3} K_{of} K_{V2}$$

or, in any case, less than 3 mm.

For hulls having **L** > 15, however, the sheerstrake is to be fitted with a height, in mm, at least equal to 0,025 **L** and thickness **t_c** not less than **t₂** or $4,2 (s/s_r) \sqrt{L-3} K_{of} K_{V2}$

9.4 Local thickness increases in external plating

9.4.1 Bottom and side in way of openings and fore and aft end structure

The thickness of bottom and side plating is to be gradually increased with respect to that given in the requirements above, in way of:

- any large openings in such plating;
- fore and aft end structure of the hull and similar structure, such as sternpost or sternframe, propeller shaft boss, rudder horn, propeller shaft brackets;
- ends of castles, as provided for in [13].

9.4.2 Plating of the bottom forward

For the thickness of the plating of the bottom forward, see [11].

9.5 Deck plating

9.5.1 The thickness **t₃**, in mm, of weather deck plating, including the stringer, is to be not less than:

$$t_3 = 2,8 \frac{S}{s_r} \sqrt{L-3} K_{of}$$

or, in any case, less than 3 mm.

For hulls having **L** > 15, however, the stringer plate is to be fitted having width at least equal to 0,025 **L** and thickness not less than:

$$t = 3,9 \frac{S}{s_r} \sqrt{L-3} K_{of}$$

For hulls having deck openings of breadth $\geq 0,3$ of the local breadth of the deck itself, the thickness of the plating at the sides of the opening is to be increased such as to compensate for the area of deck missing, taking into account any longitudinals and, when required, the provisions regarding hull longitudinal strength.

In any event, deck openings are to be well rounded at the corners.

The thickness **t**, in mm, of decks below the weather deck intended for accommodation spaces is to be not less than:

$$t = 2,1 \frac{S}{s_r} \sqrt{L-3} K_{of}$$

Decks intended for other purposes will be examined by Tasneef on a case-by-case basis taking into account the loads bearing on them.

For superstructure decks, see [13].

10 Bottom, side and deck structures

10.1 Single bottom structures

10.1.1 Longitudinal structure

The section modulus Z , in cm^3 , of bottom longitudinals is given by:

$$Z = 20sS^2hK_oK_{V3}$$

where:

h : height of the hull D , to be assumed in any case at least equal to $L/(5 + 0,1 L)$ where L = length of the hull.

The value of Z is, in any event, to be assumed not less than 20 cm^3 .

10.1.2 The section modulus Z , in cm^3 , of reinforced floors in way of the centreline of the span is given by:

$$Z = 22sS^2hK_oK_{V3}$$

where:

h : height defined in [10.1.1].

S : span, to be assumed not less than 1 m

s : spacing, in m, in general to be assumed not greater than $3 s_r$, except for high speed hulls (see [7.7]).

10.1.3 The centre girder is generally to be fitted, except in the case of a U-shaped keel or of a dead rise edge $\leq 12^\circ$. Its height is to be not less than the local height of the floors and its section modulus Z , in cm^3 , is to be not less than $60(L - 4)$.

Side girders are to be fitted such that the distance between them or to the mid-span of the hull or to the bilge plating does not exceed 2,5 m. Side girders are also to have:

- height in general not less than the local height of the floors;
- section modulus, in cm^3 , not less than $Z = 23sS^2hK_oK_{V3}$ where s = half the distance between the two longitudinals adjacent to the girder

However, when the girders form a support for the floors, the section modulus is to be not less than:

$$Z = 22bS^2hK_oK_{V3}$$

where:

b : half the distance, in m, between the two girders adjacent to that considered, except when only the centre girder is fitted, in which case b = half the total breadth of the hull.

S : girder span, in m, equal to the distance between two transverse bulkheads or between two supporting transverse structures of equivalent strength, to be taken not less than 1 m.

10.1.4 Additional floors are to be arranged in way of engine seating girders, propeller shaft struts, the rudder horn and other structures subjected to local loads.

10.1.5 Transverse structure

Ordinary floors are to be fitted at each frame and are to have a section modulus at mid-span, in cm^3 , not less than:

$$Z = 22sS^2hK_oK_{V3}$$

For additional floors, the requirements in [10.1.1] apply.

10.1.6 For girders, the requirements in [10.1.3] apply.

10.2 Double bottom structures

10.2.1 The structural scantlings of the double bottom are to comply with the requirements in [12], when the double bottom is intended to contain liquids; in any case, such scantlings are to be not less than the following, which refer to longitudinally framed double bottoms:

- thickness, in mm, of the inner bottom:

$$t = 3,1 \frac{S}{s_r} \sqrt{L - 3} K_o$$

- girders: scantlings given in [10.1.1]
- side longitudinals: section modulus Z given in [10.1.1]
- inner bottom longitudinals: section modulus $Z = 0,8$ of the Z of side longitudinals, using $K_{V3} = 1$
- floors: section modulus Z given in [10.1.2].

The scantlings of any transversely framed double bottoms will be examined by Tasneef on a case-by-case basis.

10.3 Side hull structures

10.3.1 Applicability

The requirements in [10.3] apply to hulls with one deck, i.e. the weather deck, or to hulls with two or more decks below the weather deck which are located below the draught T at full load of the vessel.

The scantlings of side hull structures in cases other than the above, for example in way of any castles above the weather deck, will be considered by Tasneef in each case on the basis of the loads acting on such structures, as laid down in Part B, Chapter 5 of the Rules.

10.3.2 Longitudinal structure

The section modulus, in cm^3 , of side longitudinals is given by:

$$Z = 20sS^2hK_oK_{V4}$$

where:

h : $0,65 D$ or, if greater, $h = 0,65 L/(5 + 0,1 L)$ for longitudinals of vessels with one deck and for longitudinals below the lower deck of vessels with two decks, while for 'tweendeck' longitudinals on vessels with two decks $h = 60\%$ of the above value.

The value of Z is to be assumed in any case not less than 15 cm^3 .

10.3.3 The section modulus, in cm^3 , of side webs is given by:

$$Z = 22sS^2hK_oK_{V4}$$

where:

- h** : value given in [10.3.2]
S : span, to be assumed not less than 1 m.

10.3.4 Transverse structure

The section modulus, in cm^3 , of ordinary frames is to be not less than:

$$Z = 20sS^2h$$

where **h** is given in [10.3.2].

Ordinary frames are to be well connected to the corresponding floor and to the corresponding beam, such as to achieve an appropriate end connection.

10.3.5 The section modulus, in cm^3 , of side webs and reinforced stringers is given by:

$$Z = 22bS^2h$$

Side webs are, as a rule, to be arranged at a spacing not greater than 5 frame spaces on hulls having height **D** > 2,5 m.

10.4 Deck structures

10.4.1 General requirements

Deck structures are intended to mean those consisting of stiffeners which may be transverse (beams) or longitudinal, generally supported by systems of primary supporting members (girders and/or transverse webs), which in turn are supported by pillars.

The pillars of the various decks are to be fitted in the same vertical line, wherever possible. Other solutions, such as girders supported by cantilevers, will be given special consideration by Tasneef in each individual case.

Pillars or equivalent additional structures are to be fitted under heavy, concentrated loads.

For the structure of forward decks and associated pillars, see also [11].

10.4.2 Symbols and associated requirements

- h** : conventional cargo height, in metres, on one deck
K₁ : coefficient relative to the zone of the deck considered.

- for vessels having **L** > 20 m, the values of **h** and **K₁** are as follows:
 - For exposed deck spaces:
 - weather deck of vessels with one deck and in the area forward of 0,12 **L** from the forward perpendicular of vessels with decks below the weather deck: **h** = 1,5; **K₁** = 1,9
 - weather deck abaft 0,12 **L** from the forward perpendicular of vessels with decks below the weather deck: **h** = 1,4; **K₁** = 1,9
 - forecastle deck forward of 0,12 **L** from the forward perpendicular: **h** = 1,5; **K₁** = 1,5
 - castle decks elsewhere: **h** = 1,3; **K₁** = 1,5
 - deckhouse deck: **h** = 1,2; **K₁** = 1,35

- for unexposed deck spaces:
 - deck intended for cargo: **h** = **h_c**; **K₁** = 1 where **h_c** = 'tweendeck height to be assumed, for the purpose of the calculation, not less than 2 m and, for flats in machinery spaces, equal to 2,5 m;
 - deck intended for accommodation:
 - weather deck and castle deck **h** = 1,3; **K₁** = 1,5; decks below: **h** = 0,8; **K₁** = 1
 - deckhouse deck: **h** = 1,2; **K₁** = 1,35
 - for vessels having **L** ≤ 20m, the values of **h** and **K₁** stated above are reduced to 70%.

K₂ : 0,007 **L** + 0,3, to be assumed in any event not less than 0,7;

γ₀ : conventional cargo mass density on one deck, equal to 0,7 t/m³ and corresponding to the unit load **q₀** = 0,7 **h** t/m² resting on the deck itself;

γ : mass density, in t/m³, of the cargo it is intended to transport on one deck; when **γ** > **γ₀** the values of **h** and **K₁** stated above are to be increased in direct proportion.

10.4.3 Longitudinal structure

The longitudinals are to have a cross-sectional area sufficient, together with the deck plating to which they are connected, to achieve the midship section modulus (when required) and to have a section modulus, in cm^3 , not less than:

$$Z = 18sS^2hK_1K_2K_0$$

or less than 12 cm^3 .

If, however, the longitudinals are fitted on a deck other than the strength deck, the value of **Z** is to be reduced to 60%.

10.4.4 The transverse webs supporting the longitudinals are to be located in way of the side webs and are to have a section modulus, in cm^3 , not less than:

$$Z = 22bS^2hK_0$$

10.4.5 Transverse structure

The ordinary beams are to have a section modulus, in cm^3 , not less than:

$$Z = 17sS^2hK_1K_2K_0$$

10.4.6 The girders supporting the beams are to have a section modulus, in cm^3 , not less than:

$$Z = 18bS^2hK_0$$

10.4.7 Concentrated loads

When a concentrated load acts on a deck, the section modulus of the supporting structures is to be increased, with respect to that determined using the above formulae, on the basis of the relevant requirements in Part B, Chapter 5, Sec 6 of the Rules. If necessary, adequate pillars are also to be fitted.

10.4.8 Pillars

The minimum section area **A**, in cm², of a steel pillar is given by:

$$A = \frac{Q}{12,5 - (0,045(l/r))}$$

where:

- l** : length of the pillar, in cm
r : minimum radius of gyration of the pillar cross-section, in cm
Q : load resting on the pillar, in kN, to be obtained from the formula:

$$Q = 6,87Fh_0 + 9,81W$$

where:

- F** : area of the deck resting on the pillar, in m²
W : load from pillars above, if any, or any other concentrated load, in kN.

The formula from which **A** is calculated refers to solid pillars of steel having tensile strength **R** = 400÷490 N/mm², to pillars consisting of seamless pipes made of steel having tensile strength **R** = 440÷540 N/mm² and to built-up tubular or prismatic pillars made of steel having tensile strength **R** = 400÷490 N/mm².

Where materials having characteristics other than those above are used, the required area may be modified in accordance with Tasneef.

In general, the thickness of tubular or closed section pillars is to be not less than 1/35 of the nominal diameter or larger side of the section.

The thickness of the face plate of built-up pillars is to be not less than 1/18 of the unsupported width of the face plate.

Structural connections ensuring an efficient load distribution are to be fitted at the ends of pillars.

11 Aft and fore end hull structures

11.1 Strengthening of the bottom forward

11.1.1 In the area between 0,05 **L** and 0,25 **L** from the forward perpendicular, the thickness of the plating of the flat bottom is to be increased, in general by 20% with respect to that required in [9]; moreover:

- if the bottom structure is longitudinally framed, the reinforced floors are to be closely spaced and, in general, fitted at intervals not exceeding two frame spaces;
- in the event of transverse framing, on the other hand, additional intermediate girders are to be fitted between those required in [10].

11.2 Side supports aft of the fore peak

11.2.1 If the side structure in the area between the collision bulkhead and 0,15 **L** from the forward perpendicular is transversely framed, stringers are to be arranged in such area in line with the side longitudinals of the fore peak.

11.3 Forward deck structures

11.3.1 The girders and transverse webs of the weather deck and of the forecastle in the area forward of 0,075 **L** from the forward perpendicular are to have a small span, preferably achieved by means of closely spaced supporting pillars, and a spacing generally not exceeding 2 m.

11.4 Fore peak

11.4.1 The type of framing inside the peak is generally to be the same as that adopted abaft the peak such as to ensure adequate structural continuity.

In those areas where the shape of the hull body is narrower, the floors are to be of increased height with respect to that of the floors in the midship section, such that the angle of incidence with the frame is as large as possible.

When longitudinal framing is adopted, the spacing of floors, frames and transverse webs is generally not to exceed three frame spaces.

The reinforced structures of the flat, if any, and of the central longitudinal bulkhead (e.g. beams and vertical webs) are to be aligned with both the reinforced deck beams and the side webs of the sides of the hull.

12 Hull subdivision bulkheads and tanks for liquids

12.1 Hull subdivision bulkheads

12.1.1 The thickness **t**, in mm, of a single-skin laminate bulkhead and the section modulus **Z**, in cm³, of the associated vertical or horizontal stiffeners are given by the following formulae:

$$t : 12s\sqrt{h_1}K_{of}$$

and, in any case, not less than 2,5 mm;

$$Z : 18sS^2h_2K_0$$

where:

- h₁** : vertical distance, in m, from the lower edge of the area of bulkhead considered to the highest point of the bulkhead;
h₂ : vertical distance, in m, from the mid-point of the vertical stiffener, or from the horizontal stiffener, to the highest point of the bulkhead;
s : spacing, in m, between the stiffeners or reinforced beams.

The value of **Z** may be reduced by 20% when the stiffeners are fitted with end brackets.

The collision bulkhead is to be dimensioned in accordance with the provisions of [12.2].

In the case of corrugated bulkheads made in single-skin laminates, the value of **s** to be assumed for the calculation of **Z** is equal to the spacing of the corrugation and the value of **s** to be assumed for the calculation of **t** is equal to the larger side of the corrugation.

The boundary connection of a bulkhead is to be carried out by means of two angle bars.

Bulkheads made in sandwich type laminates or of marine plywood are to have scantlings and connections equivalent to those stipulated above.

12.2 Tanks for liquids

12.2.1 General

Tanks intended to contain drinking or fresh water may be "structural tanks", i.e. tanks forming parts of the hull structures. Tanks intended to contain fuel oil or lubricating oil are generally to be metal tanks separated from any other hull structures, in compliance with the requirements in the specific requirements for fire protection of reinforced plastic vessels.

Tanks made of glass fibre may be accepted by Tasneef provided that they comply with the requirements in [12.3].

Structural tanks intended to contain fuel oil or lubricating oil are to be made of single-skin laminates.

Tanks are to be insulated from other hull spaces by means of diaphragms, made of laminates, fitted inside the stiffeners (longitudinal and/or transverse), so that, in the event of the stiffener laminate breaking, the liquid may not flow outside the tank through the stiffener.

Sandwich type laminates may be accepted by Tasneef on a case-by-case basis, provided that the thickness of the laminate internal skin that is in contact with the liquid is not less than 8 mm and that diaphragms are fitted for the purpose of insulating the tank from the other hull spaces.

Tanks intended to contain fuel oil or lubricating oil may be accepted by Tasneef, provided that flame-resistance tests are carried out on laminates, in accordance with the relevant Tasneef requirements. These tests may be omitted if the laminate thickness is not less than 12 mm for plating or 6 mm for stiffeners and if the laminate is covered on the internal skin (inside the tank) by a hydro-carbide resistant resin and on the external skin (outside the tank) by a self-extinguish-ing resin.

In any case, mechanical tests are to be carried out on laminate samples after immersion in fuel oil at ambient temperature for a week. The mechanical property values of the laminate after immersion are to be not less than 80% of those of the sample before immersion.

For each enclosed space, the total volume of a tank is to be not greater than 6 m³.

12.2.2 Scantlings

The thickness t , in mm, of a single-skin laminate bulkhead and the section modulus Z , in cm³, of the associated vertical or horizontal stiffeners are given by:

where:

$$t = 18s\sqrt{h_3}K_{of}$$

$$z = 36sh_1s^2K_0$$

where:

h_3 : height h_1 defined in [10.1] or height equal to half the distance from the lower edge of the bulkhead to the air pipe of the tank, whichever is the greater;

h_4 : height h_2 defined in [10.1], or height equal to half the distance from the mid-span of the stiffener to the air pipe of the tank, whichever is the greater;

s : spacing, in m, between the stiffeners or reinforced beams.

Hull structures forming the top and bottom of a tank are to be dimensioned in accordance with these requirements whenever the latter are more stringent than those pertaining to such structures.

Boundary connections of bulkheads are to be carried out by means of two angle bars, one on each side and each having:

- side of width 50 mm for the first layer plus 40 mm for each 1000 g/m² of the subsequent layers;
- thickness = 0,5 t_{min} , where t_{min} is the lesser thickness of the layers to be connected, but in any case thickness not less than 3,5 mm.

12.2.3 Divisional bulkheads

If a tank extends from side to side of the hull, a longitudinal watertight or wash bulkhead is to be fitted at mid-span.

12.2.4 Cofferdams and drainage

Fuel oil tanks are to be separated from fresh water tanks by means of cofferdams.

As an alternative to such cofferdams, a simple chamber with a drainage channel may be used to collect any leakage.

Where leakage of liquid fuel may occur, for example in way of pumps, heaters, etc., screens, drainage channels or other suitable means are to be provided to drain such leakage to special wells.

12.3 Structural fuel tanks

12.3.1 General

Structural tanks are to be intended to contain fuel oil or lube oil. No integral tanks are to contain gasoline. Integral tanks may be of single-skin laminates and sandwich construction.

12.3.2 Single-skin laminates and sandwich tanks

For single-skin laminates and sandwich construction tanks the following requirements are to be applied:

- the final ply of the laminate is to be covered with fibreglass chopped strand mat of heavy weight (at least 600 gr/m²). Alternatively, the internal thickness of the tanks is to be not less than 10 mm;
- the internal surface of the tanks is to have a heavy resin coat, which may incorporate a light fibre tissue, as a barrier to prevent any undue absorption by the laminate. This may be carried out with the use of special resin (isophaltic type) resistant to hydrocarbons. Alternatively a suitable thickness of gelcoat is to be applied;
- stiffeners are not to penetrate the tank boundaries so that, in the event of a fracture of the laminate or frame, the oil will not travel some distance along the continuous glass fibres due to a capillary action. Accordingly, the tank is to be isolated by means of diaphragms made

of laminates to form the final internal barrier layer against oil absorption;

- the outer surfaces of the tanks are to be coated with a fire-retardant paint or resin. In addition for sandwich construction tanks the following requirements are to be applied:
- the cores are to be end grain balsa or closed cell polyvinylchloride foam;
- each balsa block is to be individually set with the space around it filled with resin.

12.3.3 Single-skin laminates and sandwich tanks

Mechanical tests are to be carried out on samples of the laminate "as is" and after immersion in the fuel oil at ambient temperature for a week. After the immersion the mechanical properties of the laminate are to be not less than 80% of the value of the sample "as is". For scantling calculations the mechanical characteristics obtained by the mechanical tests are to be assumed.

12.4 Tests

12.4.1 As far as tests are concerned, the requirements in Part B, Ch 12, Sec 3 of the Rules apply.

12.5 Other bulkheads

12.5.1 Complete or partial bulkheads, other than those dealt with above, which are fitted in place of hull structures are to have scantlings equivalent to those prescribed in these Rules for such structures.

13 Superstructures

13.1 General

13.1.1 Designation of superstructures

First tier superstructures are intended as those situated on the weather deck, second tier superstructures are those immediately above, and so on.

If, however, the freeboard of the vessel in respect of the weather deck, at $0,5 L$, is greater than 1,8 m, for the purpose of structural scantlings the superstructures situated on such deck are termed second tier, those immediately above are termed third tier, and so on.

13.1.2 Materials

This item [13] stipulates the structural scantlings for reinforced plastic superstructures. The use of other material, for example aluminium alloys, and the associated scantlings will be taken into consideration by Tasneef on the basis of the requirements for the use of such material for hull construction.

13.2 Structural scantlings

13.2.1 Conventional scantling height

The conventional scantling height, which appears in the formulae for the structural scantlings of superstructures dealt with below, is equal to the following values:

- h** : 1,5 m for exposed front 1st tier bulkhead
h : 1,2 m for other superstructure bulkheads.

13.2.2 Boundary bulkheads and decks

a) Thickness of boundary bulkheads

The thickness **t**, in mm, of such bulkheads, including the sides of castles not constituting a step of the strength deck and excluding those of castles constituting a step of the strength deck, is to be not less than:

$$t = 7s\sqrt{h}K_{of}$$

and, in any case, not less than 3 mm, where:

- s** : spacing of the vertical or ordinary stiffeners of the plating
h : conventional scantling height defined above.

b) Boundary bulkhead vertical stiffeners

Except where otherwise stated in [13.2.3], the section modulus of boundary bulkhead vertical stiffeners is to be not less than **Z**, in cm³:

$$z = 6sS^2hK_o$$

and, in any case, not less than 15 cm³, where:

- S** : overall span of the vertical stiffener, in m.

The section modulus of the frames and longitudinals of castles not constituting a step of the strength deck is to be calculated using the formulae in [9] and [10]; in any event, the section modulus to be assumed is not to be less than that of the vertical stiffeners.

c) Deck thickness

Except where otherwise stated in [13.2.3], the deck plating thickness **t**, in mm, is to be not less than:

$$t = c_1(11,5s + 0,03L + 5,8)K_{of}$$

and, in any case, not less than 3 mm, where:

- c₁** : 1 for bridge and forecastle
 0,9 for poop
 0,7 for deckhouse
 0,6 for superstructures of hulls having $L < 15$ m.

d) Deck structures

Deck structures (beams, girders) are to have scantlings in accordance with [10].

13.2.3 Special superstructures

a) Sides and deck of castle constituting a step of the strength deck

Castles constituting a step of the strength deck, defined in Ch 1, Sec 1, [1.1.4], are to have the scantlings stipulated in:

- [9] for side and deck plating
- [10] for side and deck structures

If necessary, such scantlings are to be increased to achieve the midship section modulus, when required.

b) Deckhouses of considerable dimensions

The scantlings of deckhouses are given in [13.2.2]; nevertheless, for deckhouses having average breadth $\geq 0,5$

B and extending in length more than 0,15 **L** within 0,4 **L** amidvessels, it is necessary to:

- verify that the deck scantlings are such that the mid-ship section modulus, when required, in way of the deckhouse is at least equal to that which would be obtained if the deckhouse did not exist;
- strengthen the sides of the deckhouse with transverse corrugations or with vertical web frames or transverse partial bulkheads;
- ensure that all the windows and openings have well rounded corners.

13.3 Bulwarks

13.3.1 As a rule, bulwarks are to:

- have thickness not less than 90% of that of the sides of the hull within 0,4 **L** amidships;
- be supported by vertical stiffeners (stays) spaced not more than 1 m apart and connected to the deck by means of two angle bars;
- have the upper edge longitudinally strengthened, increasing the mass per area (g/m^2) of the reinforcement of the laminate or adopting an equivalent solution.

Part B
Hull and Stability

Chapter 3
ALLUMINIUM HULL

**SECTION 1 MATERIALS, CONNECTIONS AND STRUCTURE DESIGN
PRINCIPLES**

SECTION 2 DESIGN LOADS AND HULL SCANTLINGS

SECTION 1

MATERIALS, CONNECTIONS AND STRUCTURE DESIGN PRINCIPLES

1 Materials and connections

1.1 General requirements

1.1.1 Materials to be used in hull and equipment construction, in delivery condition, are to comply with these requirements or with specific requirements applicable to individual cases; they are to be tested in compliance with the applicable provisions. Quality and testing requirements for materials covered here are outlined in the relevant Tasneef Rules.

These requirements presume that welding and other cold or hot manufacturing processes are carried out in compliance with current sound working practice and the relevant Tasneef provisions. The latter, in particular, may include requirements concerning welding operations and techniques and other manufacturing processes (e.g., specific preheating before welding and/or welding or other cold or hot manu-

facturing processes followed by an appropriate heat treatment).

Welding processes are to be approved for the specified type of material for which they are intended and with limits and conditions as stated in the applicable Tasneef requirements.

1.2 Aluminium alloy hull structures

1.2.1 The designation of aluminium alloys used here complies with the numerical designation used in RRIAD (Registration Record of International Alloy Designation).

The characteristics of aluminium alloys to be used in the construction of aluminium vessel are to comply with the relevant requirements of Tasneef Rules.

As a rule, series 5000 aluminium-magnesium alloys (see Tab 1) or series 6000 aluminium-magnesium-silicon alloys (see Tab 2) are to be used.

Table 1

SERIES 5000 WROUGHT ALUMINIUM ALLOYS FOR WELDED CONSTRUCTION (Rolled products: Plates and Sections) Guaranteed mechanical characteristics (1)					
Alloy (2)	Temper (3)	Dimensions in mm	Minimum guaranteed yield stress $R_{p0.2}$ at 0,2% N/mm ²	Minimum guaranteed tensile strength R_m N/mm ²	Metallurgical efficiency coefficient β (4)
5083 (Plates)	O o H111	$t \leq 6$	125	275	1
		$t > 6$	115	275	1
5083 (Sections)	O o H111	All thicknesses	110	270	1
5086 (Plates)	O o H111	All thicknesses	100	240	1
5086 (Sections)	O o H111	All thicknesses	95	240	1
5754	O o H111	$t \leq 6$	80	190	1
		$t > 6$	70	190	1
5454	O o H111	All thicknesses	85	215	1
5454	F	All thicknesses	100	210	1

(1) The guaranteed mechanical characteristics in this Table correspond to general standard values. For more information, refer to the minimum values guaranteed by the product supplier.
(2) Other grades or tempers may be considered, subject to TASNEEF's agreement.
(3) O : annealed
H111: roller levelled after annealing
F: as fabricated.
(4) See [1.5.1].

Table 2

SERIES 5000 WROUGHT ALUMINIUM ALLOYS FOR WELDED CONSTRUCTION (Rolled products: Plates and Sections) Guaranteed mechanical characteristics (1)						
Alloy (2)	Temper (3)	Dimensions in mm	Minimum guaranteed yield stress $R_{p0.2}$ a 0,2% N/mm ²	Minimum guaranteed tensile strength R_m N/mm ²	Metallurgical efficiency coefficient β (4)	Alloy (2)
6005 A (Open Sections)	T5 or T6	$t \leq 6$ $6 < t \leq 10$ $10 < t \leq 25$	225 215 200	270 260 250	4043 $t \leq 6$ $6 < t \leq 20$	0,40
6005 A (Closed Sections)	T5 or T6	$t \leq 6$ $6 < t \leq 25$	215 200	255 250	5356 $6 < t \leq 20$	0,5
6060 (Sections) (3)	T5	$t \leq 6$ $6 < t \leq 25$	150 130	190 180	4043, $t \leq 8$ 5356, $t \leq 8$	0,6 0,65
6061 (Sections)	T6	$t \leq 25$	240	260	5356 4043	0,53 0,53
6082 (Sections)	T6	$t \leq 15$	250	290	4043, $t \leq 20$ 5356, $t \leq 20$	0,45 0,45
6106 (Sections)	T5	$t \leq 6$	195	240	4043, $t \leq 10$ 5356, $t \leq 10$	0,57

(1) The guaranteed mechanical characteristics in this Table correspond to general standard values. For more information, refer to the minimum values guaranteed by the product supplier.

(2) Other grades or tempers may be considered, subject to TASNEEF's agreement.

(3) 6060 alloy is not to be used for structural members sustaining impact loads (e.g. bottom longitudinals). The use of alloy 6106 is recommended in such cases.

(4) T5 : artificially aged
T6 : solution heat treated and artificially aged.

(5) See [1.5.1].

The use of series 6000 alloys or extruded plates, for parts which are exposed to sea water atmosphere, will be considered in each separate case by Tasneef, also taking into account the protective coating applied.

The list of aluminium alloys given in Tab 1 and Tab 2 is not exhaustive. Other aluminium alloys may be considered, provided the specification (manufacture, chemical composition, temper, mechanical properties, welding, etc.) and the scope of application are submitted to Tasneef for review.

In the case of welded structures, alloys and welding processes are to be compatible and appropriate, to the satisfaction of Tasneef and in compliance with the relevant Rules.

For forgings or castings, requirements for chemical composition and mechanical properties will be defined in each separate case by Tasneef.

In the case of structures subjected to low service temperatures or intended for other particular applications, the alloys to be employed will be defined in each separate case by Tasneef, which will state the acceptability requirements and conditions.

Unless otherwise specified, Young's modulus for aluminium alloys is equal to 70000 N/mm² and Poisson's ratio equal to 0,33.

1.3 Extruded plating

1.3.1 Extrusions with built-in plating and stiffeners, referred to as extruded plating, may be used.

In general, the application is limited to decks and deck-houses. Other uses may be permitted at the discretion of Tasneef.

Extruded plating is preferably to be oriented so that the stiffeners are parallel to the direction of main stresses.

Connections between extruded plating and primary members are to be given special attention.

1.4 Tolerances

1.4.1 The under-thickness tolerances of plates and rolled sections are to be in accordance with Tab 3.

The under-thickness tolerances of extruded plating are to be in accordance with Tab 4.

The responsibility for maintaining the required tolerances lies with the Manufacturer, who is also to inspect the surface condition.

1.5 Influence of welding on mechanical characteristics

1.5.1 Welding heat input lowers locally the mechanical strength of aluminium alloys hardened by work hardening (series 5000 other than condition 0 or H111) or by heat treatment (series 6000).

Consequently, where necessary, a drop in mechanical characteristics of welded structures is to be considered in the heat-affected zone, with respect to the mechanical characteristics of the parent material.

The heat-affected zone may be taken to extend 25 mm on each side of the weld axis.

Aluminium alloys of series 5000 in 0 condition (annealed) or in H111 condition (annealed flattened) are not subject to a drop in mechanical strength in the welded areas.

Aluminium alloys of series 5000 other than condition 0 or H111 are subject to a drop in mechanical strength in the welded areas. The mechanical characteristics to consider are, normally, those of condition 0 or H111. Higher mechanical characteristics may be taken into account, provided they are duly justified.

Aluminium alloys of series 6000 are subject to a drop in mechanical strength in the vicinity of the welded areas. The mechanical characteristics to be considered are, normally, to be indicated by the supplier.

Table 3

As-built thickness t , in mm	Under-thickness tolerance, in mm
$t \leq 8$	0,3
$8 < t \leq 12$	0,5
$12 < t \leq 20$	0,7
$t > 20$	1

Table 4

As-built thickness t , in mm	Under-thickness tolerance, in mm
$t \leq 6$	0,3
$6 < t \leq 10$	0,4

1.6 Material factor K for scantlings of structural members made of aluminium alloy

1.6.1 The value of the material factor **K** to be introduced into formulae for checking scantlings of structural members, given in this Chapter and the various Appendices, is determined by the following equation:

$$K = \frac{100}{\eta \cdot R_{p0,2}}$$

where:

$R_{p0,2}$: is the minimum guaranteed yield stress, in N/mm², of the parent material in delivery condition

η : is the joint coefficient for the welded assembly, corresponding to the aluminium alloy considered, given in Tab 5

$R'_{p0,2}$: is the minimum guaranteed yield stress, in N/mm², of metal in welded condition, i.e.:

- condition 0 or H111 for series 5000 alloys (see [1.5]),
- to be indicated by the supplier for series 6000 alloys (see [1.5]).

For welded constructions in hardened aluminium alloys (series 5000 other than condition 0 or H111 and series 6000), greater characteristics than those in annealed or welded condition may be considered, provided that welded connections are located in areas where stress levels are acceptable for the alloy considered in annealed or welded condition.

In the case of welding of two different aluminium alloys, the material factor **K** to be considered for the scantlings of welds is to be the greater material factor of the aluminium alloys of the assembly.

Table 5

Alloys	η
- Aluminium alloys without work-hardening treatment (series 5000 in annealed condition 0 or annealed flattened condition H111)	1
- Aluminium alloys hardened by work hardening (series 5000 other than condition 0 or H111)	$R'_{p0,2} / R_{p0,2}$
- Aluminium alloys hardened by heat treatment (series 6000)	$R'_{p0,2} / R_{p0,2}$ (1)
(1) Should no information be available, coefficient η is to be taken as the coefficient of metallurgical efficiency defined in Tab 1 and Tab 2, without being less than 0,4 or more than 0,6.	

1.7 Fillet welding

1.7.1 The effective length, in mm, of the weld beads is given by:

$$d_e = d - 20$$

where **d** is the actual length, in mm, of the weld bead.

1.8 Riveted connections for aluminium alloy hulls

1.8.1 Use of rivets for connecting structures is limited, in principle, only to members which do not contribute to the overall strength of the hull. Exceptions are to be supported by experimental evidence or good in-service performance.

The conditions for riveted connection acceptability are to be individually stated in each particular case, depending on the type of member to be connected and the rivet material.

Whenever riveted connections are to be employed, a detailed plan, illustrating the process as well as the dimen-

sions and location of rivets and holes, together with the mechanical and metallurgical properties of the rivets, is to be submitted for approval.

Tasneef may, at its discretion, require tension, compression and shear tests to be carried out on specimens of riveted connections constructed under the same conditions as during actual hull construction, to be witnessed by a Tasneef Surveyor.

Tasneef reserves the right to accept the results of tests performed by recognized bodies or other Societies.

1.9 Welded connections

1.9.1 General requirements

For welding, the requirements of the relevant Tasneef Rules apply. In particular, these provisions make the adoption of welding procedures dependent on their previous qualification by Tasneef. In addition, individual builders are to hold an authorization by Tasneef to use these procedures, employing welders qualified by Tasneef.

1.9.2 Accessibility and edge preparation

For correct execution of welded joints, sufficient accessibility is necessary, depending on the welding process adopted and the welding position.

Edge cutting, to be carried out in general by machining, is to be regular and without burrs or cuts.

The structural parts to be welded as well as those adjacent, even if they have been previously pickled, are to be cleaned carefully before welding, using suitable mechanical means, such as stainless steel wire brushes, so as to eliminate oxides, grease or other foreign bodies which could give rise to welding defects.

Edge preparation, alignment of joints, spot-welding methods and root chipping are to be appropriate to the type of joint and welding position, and comply with Tasneef requirements for the welding procedures adopted.

1.9.3 Inspections

Inspections of welded connections by Tasneef Surveyors are, in general, those specified in (a) to (e) below. The extent of inspection will be defined by Tasneef on a case by case basis.

- a) Inspection of base materials for compliance with the requirements in this Article and of structures with the approved plans.
- b) Inspection of the use and application conditions of welding procedures for compliance with those approved and verification that qualified welders are employed.
- c) Visual examination of edge preparations, root chipping and execution of welds in way of structural connections.
- d) Examination of radiographs of welded joints (radiographing is to be performed, if necessary, depending on the extent of the examinations), and inspection of per-

formance of the ultrasonic or magnetic particle examinations which may be required.

- e) Inspection of any repairs, to be performed with procedures and inspection methods at the discretion of Tasneef surveyor.

Irrespective of the extent of such inspections, it is the responsibility of the builder to ensure that the manufacturing procedures, processes and sequences are in compliance with the relevant Tasneef requirements, approved plans and sound working practice. For this purpose, the shipyard is to have its own production control organization.

1.9.4 Welding processes for light alloys

In general, the welding of the hull structures is to be performed with the MIG (metal-arc inert gas) and TIG (tungsten-arc inert gas) processes using welding consumables recognized as suitable for the base material to be used. Welding processes and filler materials other than those above will be individually considered by Tasneef at the time of approval of welding procedures.

For authorization to use welding procedures in production, the following details are to be stated:

- a) grade and temper of parent and filler materials
- b) weld execution procedures: type of joint (e.g. butt-joint, fillet joint); edge preparation (e.g. thicknesses, bevelling, right angle edges); welding position (e.g. flat, vertical, horizontal) and other parameters (e.g. voltage, amperage, gas flow capacity)
- c) welding conditions (e.g. cleaning procedures of edges to be welded, protection from environmental atmosphere)
- d) special operating requirements for butt-joints, for example for plating: welding to be started and completed on end pieces outside the joint, back chipping, arrangements for repairs consequent to possible arc restarts
- e) type and extent of controls during production.

1.10 Corrosion protection - Heterogeneous steel/aluminium alloy assembly

1.10.1 Connections between aluminium alloy parts, and between aluminium alloy and steel parts, if any, are to be protected against corrosion by means of coatings applied by suitable procedures agreed by Tasneef.

In any case, any direct contact between steel and aluminium alloy is to be avoided (e.g. by means of zinc or cadmium plating of the steel parts and application of a suitable coating on the corresponding light alloy parts).

Any heterogeneous jointing system is subject to TASNEEF's agreement.

The use of transition joints made of aluminium/steel-clad plates or profiles is subject to TASNEEF's agreement.

Transition joints are to be type-approved.

Qualifications tests for welding procedures are to be carried out for each joint configuration.

2 Structure design principles

2.1 Protection against corrosion

2.1.1 Scantlings stipulated in Sec 4 assume that the materials used are chosen and protected in such a way that the strength lost by corrosion is negligible.

2.1.2 The Shipyard is to give Tasneef a document specifying all the arrangements made to protect the material against corrosion at the construction stage: coating types, number and thickness of layers, surface preparation, application conditions, control after completion, anodic protection, etc.

2.1.3 This document is also to include maintenance arrangements to be made in service to restore and maintain the efficiency of this protection, whatever the reasons for its weakening, and whether or not incidental.

All such maintenance operations are to be listed in a book shown to the Tasneef Surveyor in charge upon request.

2.2 Rounding-off

2.2.1 Values for thickness as obtained from formulae are to be rounded off to the nearest standard value, without such a reduction exceeding 3 per cent.

SECTION 2

DESIGN LOADS AND HULL SCANTLINGS

1 Design loads

1.1 Application

1.1.1 The requirements in Ch 2, Sec 3, [2], Ch 2, Sec 3, [3] and Ch 1, Sec 3, [4] apply.

2 Hull scantlings

2.1

2.1.1 This Article stipulates requirements for the scantlings of hull structures (plating, stiffeners, primary supporting members). The loads acting on such structures are to be calculated in accordance with Ch 2, Sec 2, [5].

In general, for vessels with speed $V > 45$ knots, the scantlings of transverse structures are to be verified also by direct calculations carried out in accordance with Ch 2, Sec 2, [5].

For all other vessels, Tasneef may, at its discretion and as an alternative to the requirements of this Article, accept scantlings for transverse structures of the hull based on direct calculations in accordance with Ch 2, Sec 2, [5].

2.2 Definitions and symbols

2.2.1 "Rule bracket" - A bracket with arms equal to $l/8$, l being the span of the connected stiffener. Where the bracket connects two different types of stiffeners (frame and beam, bulkhead web and longitudinal stiffener, etc.), the value of l is to be that of the member with the greater span, or according to criteria specified by Tasneef.

- t : thickness, in mm, of plating and deck panels;
- Z : section modulus, in cm^3 , of stiffeners and primary supporting members;
- s : spacing of stiffeners, in m, measured along the plating;
- l : overall span of stiffeners, in m, i.e. the distance between the supporting elements at the ends of the stiffeners (see Fig 4);
- S : conventional scantling span of primary supporting members, in m, to be taken as given in the examples in Fig 5. Special consideration is to be given to conditions different from those shown. In no case is S to be less than $1,1 S_0$, S_0 being the distance between the internal ends of the conventional brackets as indicated in Fig 5 or, if there are no brackets, between the ends of the members;
- b : actual surface width of the load bearing on primary supporting members; for usual arrangements $b = 0,5 \cdot (l_1 + l_2)$, where l_1 and l_2 are the

spans of stiffeners supported by the primary supporting member;

- p : design pressure, in kN/m^2 , calculated as defined in Ch 1, Sec 3, [4];
- σ_{am} : permissible normal stress, in N/mm^2 ;
- τ_{am} : permissible shear stress, in N/mm^2 ;
- K : material factor defined in Sec 1, [1.6];
- e : σ_p / σ_{bl} , ratio between permissible and actual hull girder longitudinal bending stresses (see [2.4]);
- σ_p : maximum admissible stress, in N/mm^2 , as defined in [2.4.1];
- σ_{bl} : longitudinal bending stress, in N/mm^2 , as defined in [2.4.1];
- μ : $\left(1,1 - 0,5 \cdot \left(\frac{s}{l}\right)^{0,5}\right)$, which is not to be taken greater than 1,0.

2.3 Minimum thicknesses

2.3.1 In general, the thicknesses of plating, stiffeners and primary supporting members are to be not less than the minimum values.

Lesser thicknesses may be accepted provided that their adequacy in relation to strength against buckling and collapse is demonstrated to the satisfaction of Tasneef. Adequate provision is also to be made to limit corrosion.

Table 1

Element	Minimum thickness (mm)
Shell plating:	
- Bottom shell plating	$1,35 \cdot L^{1/3} \geq 2,5$
- Side shell plating	$1,15 \cdot L^{1/3} \geq 2,5$
Deck plating	2,5
Bulkhead plating	2,5
Deckhouse side shell plating	2,5

2.4 Overall strength

2.4.1 Longitudinal strength

In general, the scantlings resulting from local strength calculations in this Article are such as to ensure adequate longitudinal strength of the hull girder for the vessel.

Specific longitudinal strength calculations are required for each of the following cases:

- vessel whose hull geometry suggests significant bending moments in still water with the vessel at rest;
- vessel with large openings on the strength deck

Longitudinal strength calculations are, as a rule, to be carried out for the hull transverse section where the bending moment is maximum.

Longitudinal stress, in N/mm², in each point of the structures contributing to the vessel longitudinal strength is obtained from the following equations:

- at bottom:

$$\sigma_{bl} = \frac{M_{bl}}{W_b} \cdot 10^{-3}$$

- at main deck:

$$\sigma_{bl} = \frac{M_{bl}}{W_d} \cdot 10^{-3}$$

- at height z above the bottom:

$$\sigma_{bl} = M_{bl} \cdot \left[\frac{1}{W_b} - \left(\frac{1}{W_b} + \frac{1}{W_d} \right) \cdot \frac{z}{D} \right] \cdot 10^{-3}$$

where:

M_{bl} : total bending moment, in kN · m, defined in Ch 2, Sec 3, [3.1].

W_b, W_d : section modulus, in m³, respectively at bottom and main deck at the stress calculation point of the vessel section under consideration. In the section modulus calculation, all the elements contributing to longitudinal strength are to be considered, including long deckhouses, as appropriate.

The values of stress σ_{bl} are not to exceed σ_p , with $\sigma_p = 70/K$ N/mm².

Moreover, the compressive values of σ_p are not to exceed the values of critical stresses for plates and stiffeners calculated according to [2.5].

2.4.2 Transverse strength of twin-hull vessel

The equivalent Von Mises stresses obtained for load conditions in Ch 2, Sec 2, [3.2.2] and Ch 2, Sec 2, [3.2.3] are not to exceed $75/K$ N/mm².

The compressive values of normal stresses and the shear stresses are not to exceed the values of critical stresses for plates and stiffeners calculated according to [2.5].

In general, the bottom of the cross-deck is to be constituted by continuous plating for its entire longitudinal and transverse extension. Alternative solutions may, however, be examined by Tasneef on the basis of considerations pertaining to the height of the cross-deck above the waterline and to the motion characteristics of the vessel.

In the special case of twin-hull vessel, when the structure connecting both hulls is formed by a deck with single plating stiffened by n reinforced beams, the normal and shear stresses in the beams for the load condition in Ch 2, Sec 2, [3.2.3] can be calculated as indicated in [2.4.3].

For vessel with speed $V > 45$ knots, or for those vessel whose structural arrangements do not permit a realistic assessment of stress conditions based on simple models, the transverse strength is to be checked by means of direct cal-

culations carried out in accordance with the criteria specified in Ch 2, Sec 2, [5].

2.4.3 Transverse strength in the special case of twin-hull vessel when the structure connecting both hulls is formed by a deck with single plate stiffened by n reinforced beams

See Fig 6; G is the centre of the stiffnesses r_i of the n beams. Its position is defined by:

$$a = \frac{\sum r_i \cdot x_i}{\sum r_i}$$

where:

a : the abscissa, in m, of the centre G with respect to an arbitrarily chosen origin O

r_i : $\frac{12 \cdot E_i \cdot I_i}{S_i^3} \cdot 10^6$, in N/m

E_i : Young's modulus, in N/mm², of the beam i

I_i : bending inertia, in, in m⁴, of the beam i

S_i : span, in m, of the beam i between the inner faces of the hulls

x_i : abscissa, in m, of the beam i with respect to the origin O .

If F_i , in N, is the force taken over by the beam i , the deflection y_i , in m, of the hull in way of the beam i , is:

$$y_i = \frac{F_i \cdot S_i^3 \cdot 10^{-6}}{12 \cdot E_i \cdot I_i} = \frac{F_i}{r_i} = d_i \cdot \omega$$

d_i : $x_i - a$, abscissa, in m, of the beam i in relation to G

ω : rotation angle, in rad, of one hull in relation to the other around a transverse axis passing through G .

Considering that the transverse torsional moment (see Ch 2, Sec 2, [3.2.3])

$$M_{tt} = \sum F_i \cdot d_i \cdot 10^{-3}$$

the formula for ω may be obtained:

$$\omega = \frac{M_{tt}}{\sum r_i \cdot d_i^2} \cdot 10^3$$

As M_{tt} , r_i and d_i are known, and ω thus deduced, the force F_i , in N, the bending moment M_i , in N · m, and the corresponding normal and shear stresses can be evaluated in each beam:

$$F_i = \omega \cdot r_i \cdot d_i$$

$$M_i = F_i \cdot S_i / 2$$

Note 1: Beams calculated by the above method are assumed to be fixed in each hull as beams in way of bulkheads inside hulls. For this hypothesis to be correct, the beams are to extend over the whole breadth of both hulls and their stiffness is to be kept the same over the entire span inside and outside the hulls.

Figure 1 : Examples of conventional spans of ordinary steffners

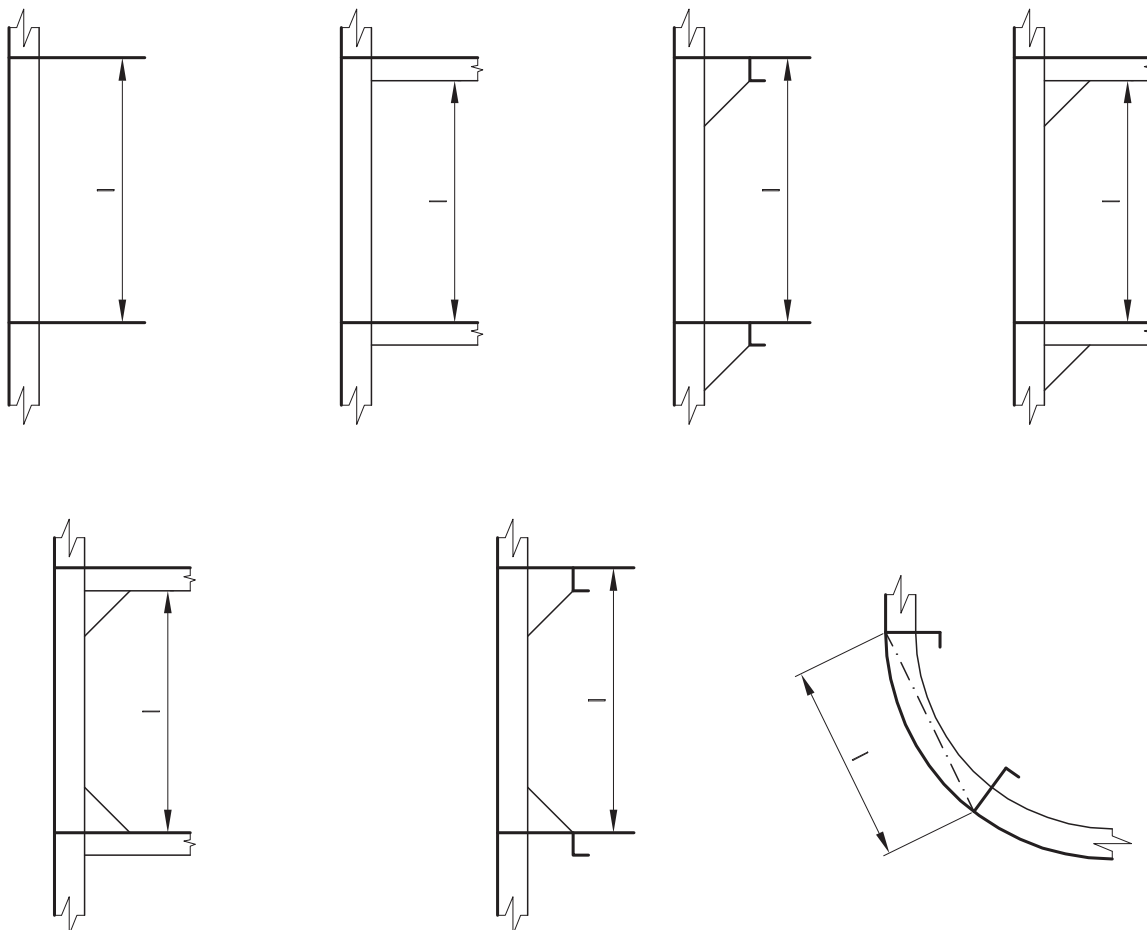
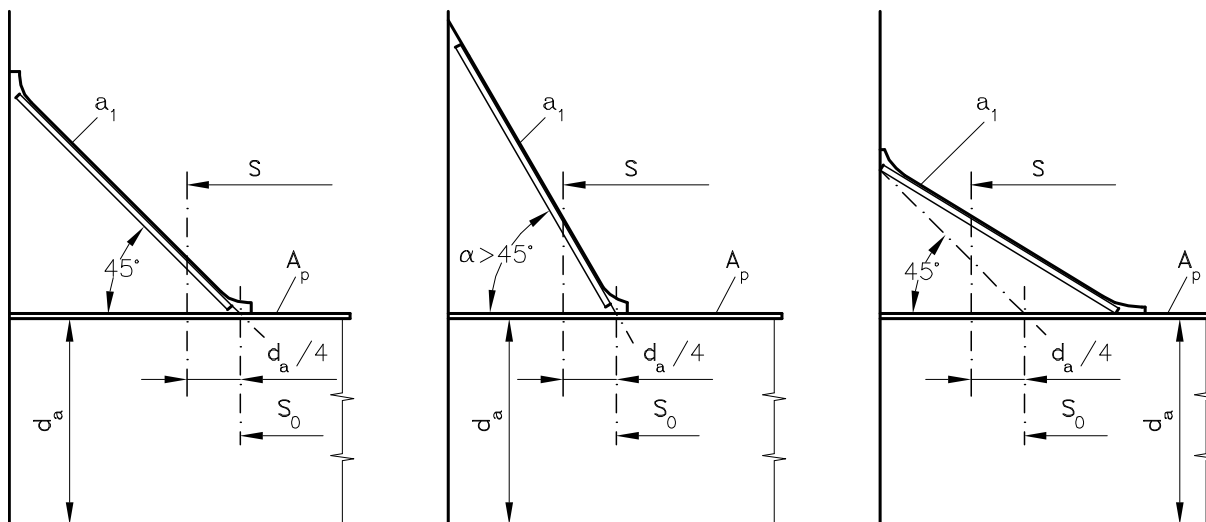

Figure 2 : Examples of conventional spans of primary supporting members



A_p = area of girder face plate
 a_1 = area of bracket face plate
 $a_1 \geq 0,5 A_p$

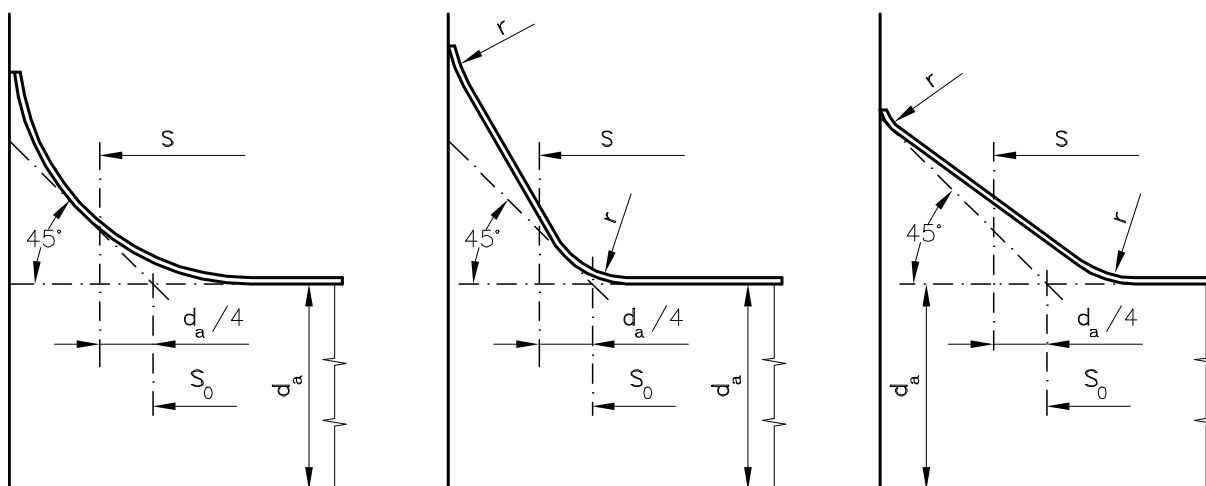
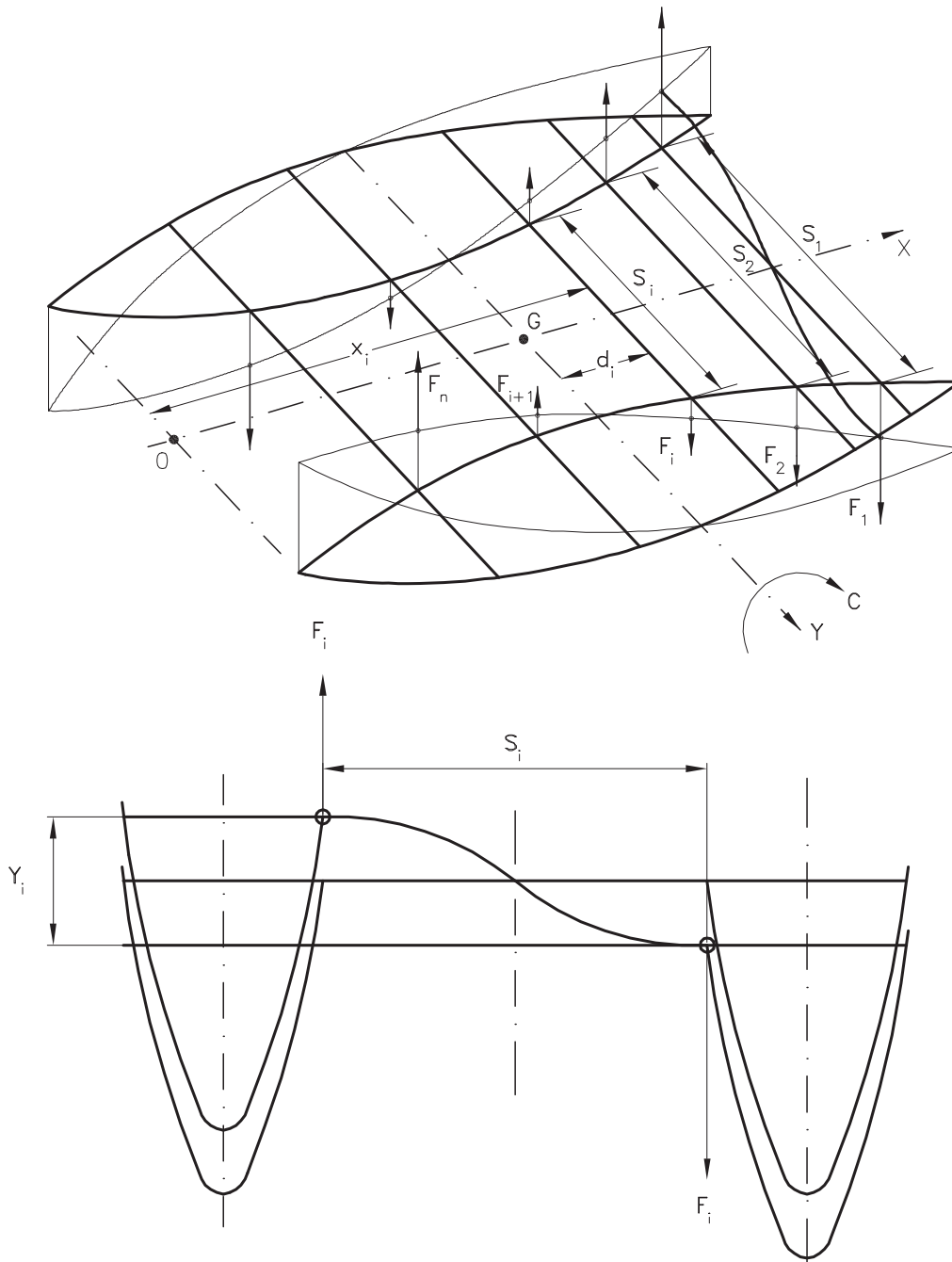

Figure 3



2.5 Buckling strength of aluminium alloy structural members

2.5.1 Application

These requirements apply to aluminium alloy plates and stiffeners subjected to compressive loads, to calculate their buckling strength.

2.5.2 Elastic buckling stresses of plates

a) Compressive stress

The elastic buckling stress, in N/mm², is given by:

$$\sigma_E = 0,9 \cdot m_c \cdot \varepsilon \cdot \left(\frac{t}{1000 \cdot a} \right)^2$$

where:

m : coefficient equal to:

$(1 + \gamma^2)^2$ for uniform compression ($\psi = 1$);

$$1 + \frac{\gamma}{\gamma_1} (\mathbf{m}_1 - 1), \quad \text{for compression-bending stress}$$

$$(0 \leq \psi \leq 1), \quad \text{if } (\gamma < \gamma_1)$$

$$\frac{2,1}{1,1 + \psi} \cdot (1 + \gamma^2), \quad \text{for compression-bending stress}$$

$$(0 \leq \psi \leq 1) \quad \text{if } \gamma \geq \gamma_1$$

$$\mathbf{m}_1 : \frac{2,1}{1,1 + \psi} \cdot (1 + \gamma_1^2)^2$$

t : plate thickness, in mm,

E : Young's modulus, in N/mm², to be taken equal to 0,7 · 10⁵ N/mm²;

a : shorter side of plate, in m;

c : unloaded side of plate, in m;

d : loaded side of plate, in m;

Ψ : ratio between smallest and largest compressive stress in the case at linear variation across the panel (0 ≤ Ψ ≤ 1);

γ : $\frac{\mathbf{c}}{\mathbf{d}}$, to be not greater than 1;

$$\gamma_1 : \left(\frac{\left(4 - \frac{1,1 + \psi}{0,7} \right)^{0,5} - 1}{3} \right)^{0,5}$$

ε : coefficient equal to:

- 1, for edge **d** stiffened by a flat bar or bulb section, and $\gamma \geq 1$
- 1,1, for edge **d** stiffened by angle- or T-section, and $\gamma \geq 1$
- 1,1, for edge **d** stiffened by flat bar or bulb section, and $\gamma < 1$
- 1,25, for edge **d** stiffened by angle- or T-section, and $\gamma < 1$

b) Shear stress

The elastic buckling stress, in N/mm², is given by:

$$\tau_E = 0,9 \cdot \mathbf{m}_t \cdot \mathbf{E} \cdot \left(\frac{\mathbf{t}}{1000 \cdot \mathbf{a}} \right)^2$$

where:

$$\mathbf{m}_t : 5,34 + 4 \cdot \left(\frac{\mathbf{a}}{\mathbf{b}} \right)^2$$

E, **t** and **a** are given in (a)

b : longer side of plate, in m.

2.5.3 Critical buckling stress

a) Compressive stress

The critical buckling stress, in N/mm², is given by:

$$\sigma_c = \sigma_E \quad \text{if} \quad \sigma_E \leq \frac{\mathbf{R}_{p0,2}}{2}$$

$$\sigma_c = \mathbf{R}_{p0,2} \cdot \left(1 - \frac{\mathbf{R}_{p0,2}}{4 \cdot \sigma_E} \right) \quad \text{if} \quad \sigma_E > \frac{\mathbf{R}_{p0,2}}{2}$$

where:

R_{p0,2} : minimum guaranteed yield stress of aluminium alloy used, in N/mm², in delivery condition

σ_E : elastic buckling stress calculated according to [2.5.2], (a) above.

b) Shear stress

The critical buckling stress, in N/mm², is given by:

$$\tau_c = \tau_E \quad \text{if} \quad \tau_E \leq \frac{\tau_F}{2}$$

$$\tau_c = \tau_F \cdot \left(1 - \frac{\tau_F}{4 \cdot \tau_E} \right) \quad \text{if} \quad \tau_E > \frac{\tau_F}{2}$$

where:

$$\tau_F : \frac{\mathbf{R}_{p0,2}}{3^{0,5}}$$

R_{p0,2} : minimum guaranteed yield stress of aluminium alloy used, in N/mm², in delivery condition

τ_E : elastic buckling stress calculated according to [2.5.2], (b).

2.5.4 Axially loaded stiffeners

a) Elastic flexural buckling stress

The elastic flexural buckling stress, in N/mm², is given by:

$$\sigma_E = 69,1 \cdot \left(\frac{\mathbf{r}}{1000 \cdot \mathbf{c}} \right)^2 \cdot \mathbf{m} \cdot 10^4$$

where:

r : $10 \left(\frac{\mathbf{I}}{\mathbf{S} + \phi \cdot \mathbf{t} \cdot 10^{-2}} \right)^{0,5}$ gyration radius, in mm,

I : moment of inertia of the stiffener, in cm⁴, calculated with a plate flange of width equal to ϕ

φ : smaller of: 800 · **a** and 200 · **c**

S : area of the cross-section of the stiffener, in cm², excluding attached plating

m : coefficient depending on boundary conditions:

- 1, for a stiffener simply supported at both ends,
- 2, for a stiffener simply supported at one end and fixed at the other one,
- 4, for a stiffener fixed at both ends.

b) Local elastic buckling stresses

The local elastic buckling stresses, in N/mm², are given by:

- for flat bars:

$$\sigma_E = 55 \cdot \left(\frac{\mathbf{t}_w}{\mathbf{h}_w} \right)^2 \cdot 10^3$$

- built up stiffeners with symmetrical flange:

$$\sigma_E = 27 \cdot \left(\frac{\mathbf{t}_w}{\mathbf{h}_w} \right)^2 \cdot 10^4 \text{ web}$$

$$\sigma_E = 11 \cdot \left(\frac{\mathbf{t}_f}{\mathbf{b}_f} \right)^2 \cdot 10^4 \text{ flange}$$

where:

h_w : web height, in mm,

t_w : web thickness, in mm,

b_f : flange width, in mm,

t_f : flange thickness, in mm.

c) **Critical buckling stress**

The critical buckling stress, in N/mm², is given by:

$$\sigma_c = \sigma_E \quad \text{if} \quad \sigma_E \leq \frac{\eta \cdot R_{p0,2}}{2}$$

$$\sigma_c = \eta \cdot R_{p0,2} \cdot \left(1 - \frac{\eta \cdot R_{p0,2}}{4 \cdot \sigma_E}\right) \quad \text{if} \quad \sigma_E > \frac{\eta \cdot R_{p0,2}}{2}$$

where:

- $R_{p0,2}$: minimum guaranteed yield stress of aluminium alloy used, in N/mm², in delivery conditions
- η : joint coefficient for the welded assembly, defined in Sec 2, [1.6]
- σ_E : either overall elastic buckling stress or local elastic buckling stress calculated according to (a) and (b) above, whichever is the lesser.

2.6 Plating

2.6.1 Formula

The thickness, in mm, required for the purposes of resistance to design pressure, is given by the formula:

$$t = 22,4 \cdot \mu \cdot s \cdot \left(\frac{p}{\sigma_{am}}\right)^{0,5}$$

Pressure p , in kN/m², and permissible stress σ_{am} , in N/mm², are defined in requirements stipulated in [2.6.3] to [2.6.8] for the various parts of the hull.

2.6.2 Keel

The thickness of keel plating is to be not less than that required for adjacent bottom plating.

This requirement may be waived in the case of special arrangements for dry-docking of vessel of unusual hull design in the opinion of Tasneef.

2.6.3 Bottom shell and bilge plating

The minimum required thickness is to satisfy the requirements of the formula in [2.6.1] under the following two conditions:

- a) p = impact pressure p_{sl} on the bottom as defined in Ch 2, Sec 3, [4.3] (in the case of slamming on the bottom), where $\sigma_{am} = 95/K$ N/mm²
- b) p = sea pressure p_s defined in Ch 2, Sec 2, [4.5], where $\sigma_{am} = 85/K$ N/mm²

The thickness of bilge plating is not, in any case, to be less than that of the bottom and side adjacent, whichever is the greater.

The thickness of plates connected to the stern frame, or in way of propeller shaft brackets, is to be at least 1,5 times the thickness of the adjacent plating.

In vessel fitted with a bow thruster, the thickness of the connection with the housing of such propeller will be considered individually by Tasneef.

2.6.4 Sea intakes and other openings

Sea intakes and other openings are to be well rounded at the corners and located, as far as practicable, well clear of sharp edges.

Sea chests are to have scantlings as for watertight tank bulk-heads (see [2.10]) taking a design pressure p_t , in kN/m², equal to:

$$p_t = p_s + 0,5 \cdot p_{sl}$$

where p_s and p_{sl} are as defined in Ch 2, Sec 2, [4.5] and Ch 2, Sec 2, [4.3] respectively.

2.6.5 Plating of side shell and front walls

The minimum required thickness is given by the formula in [2.6.1], assuming:

- p = sea pressure p_s defined in Ch 2, Sec 2, [4.5], for side shell plating;
- p = sea pressure p_{sf} defined in Ch 2, Sec 2, [4.6], for front wall plating;
- $\sigma_{am} = 85/K$ N/mm².

If front walls are located at the fore end of the hull, the pressure p_{sf} (see Ch 2, Sec 2, [4.6]) and the allowable stresses will be considered individually by Tasneef.

The thickness of the sheerstrake is to be not less than that of the side or stringer plate.

At the ends of deckhouses, the thickness of the sheerstrake is to be suitably increased.

Where side scuttles or windows or other openings are located on the sheerstrake, the thickness is to be increased to compensate for the openings.

2.6.6 Plating of cross-deck bottom and internal sides of twin-hull vessel

The minimum required thickness for the bottom of the cross-deck is given by the formula in [2.6.1], assuming:

- a) p = deck pressure p_{sl} as defined in Ch 2, Sec 2, [4.4];
- $\sigma_{am} = 95/K$ N/mm²
- b) p = sea pressure p_s as defined in Ch 2, Sec 2, [4.5];
- $\sigma_{am} = 85/K$ N/mm²

Moreover, the thickness of internal sides may be intermediate between that of the bottom of hulls and the bottom of the cross-deck. In any case, it is to be no less than that required in [2.6.1] for external sides.

2.6.7 Deck plating

The minimum required thickness is given by the formula in [2.6.1], assuming:

- p = deck pressure p_d as defined in Ch 2, Sec 2, [4.8];
- $\sigma_{am} = 85/K$ N/mm².

The thickness, in mm, of decks intended for the carriage of vehicles is to be not less than the value calculated by the formula:

$$t = f \cdot (c \cdot P \cdot K)^{0,5}$$

where:

- f : coefficient equal to 5,6
- c : coefficient given in Tab 2 as a function of the dimensions u and v of the tyre print (see Fig 4)
- p : static load on the tyre print, in kN, increased by $(1 + 0,4 \cdot a)$

Table 2 : Coefficient c as a function of u and v

b / s	u / s → v / u ↓	0,1	0,2	0,3	0,4	0,5	0,6	0,7	0,8	0,9	1,0
1	0,5	0,242	0,174	0,138	0,113	0,094	0,080	0,077	0,060	0,052	0,045
	1	0,222	0,160	0,122	0,099	0,079	0,066	0,055	0,045	0,037	0,030
	2	0,198	0,134	0,098	0,073	0,053	-	-	-	-	-
	3	0,175	-	-	-	-	-	-	-	-	-
1,4	0,5	0,228	0,189	0,158	0,128	0,111	0,096	0,083	0,073	0,064	0,056
	1	0,217	0,177	0,143	0,116	0,098	0,082	0,070	0,060	0,051	0,043
	2	0,196	0,153	0,119	0,092	0,072	0,058	0,046	-	-	-
	3	0,178	0,134	0,100	0,072	-	-	-	-	-	-
≥ 2,5	0,5	0,232	0,196	0,163	0,135	0,117	0,100	0,087	0,077	0,067	0,059
	1	0,219	0,184	0,150	0,123	0,105	0,088	0,076	0,066	0,056	0,048
	2	0,199	0,161	0,129	0,101	0,082	0,067	0,055	0,046	0,037	0,031
	3	0,185	0,142	0,108	0,083	0,064	0,051	0,038	0,028	0,019	0,012

a_v : design vertical acceleration, defined in Ch 2, Sec 2, [2].

Where there are double wheels, the tyre print consists of both.

The Designer is to supply details of tyre pressure, wheel dimensions, loads on wheels and tyre print dimensions. Where this information is not available, an approximate value of the thickness, in mm, may be obtained from the following formula:

$$t = f_1 \cdot C_1 \cdot (P_1 \cdot K)^{0,5}$$

where:

f_1 : coefficient equal to 0,38

C_1 : coefficient equal to:

- 3,60, for vehicles with 4 wheels per axle
- 4,45, for vehicles with 2 wheels per axle

P_1 : static axle load, in kN, increased by $(1 + 0,4 \cdot a_v)$

a_v : design vertical acceleration, as defined in Ch 2, Sec 2, [2].

The thickness of areas of watertight decks or flats forming steps in watertight bulkheads or the top or the bottom of a tank is also to comply with the provisions of [2.10].

Figure 4

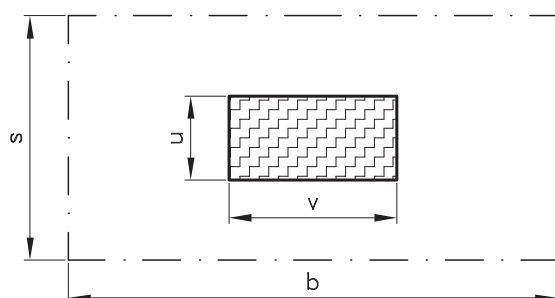

2.6.8 Plating of deckhouse boundary walls

The minimum required thickness is given by the formula in [2.6.1], assuming:

- p = sea pressure p_{su} as defined in Ch 2, Sec 2, [4.7];
- $\sigma_{am} = 85/K$ N/mm².

Openings (doors, windows) are to be well rounded at the corners.

Where there is no access from inside deckhouses to 'tween-decks below or where one of the boundary walls concerned is in a particularly sheltered position, reduced scantlings compared with those above may be accepted, at the discretion of Tasneef.

For unprotected front walls located at the fore end, the pressure p_{su} and allowable stresses will be considered individually by Tasneef.

2.7 Ordinary stiffeners

2.7.1 General

This Article states the requirements to be complied with for ordinary stiffeners of the bottom, sides, decks and, for twin-hull vessel, the cross-deck and internal sides.

The section modulus Z , in cm³, and the shear area A_t , in cm², required for the purpose of supporting the design pressure transmitted by the plating, are given by the following formulae:

$$Z = 1000 \cdot \frac{l^2 \cdot s \cdot p}{m \cdot \sigma_{am}}$$

$$A_t = 5 \cdot \frac{l \cdot s \cdot p}{\tau_{am}}$$

where m is a coefficient depending on the type of stiffener and on whether there are Rule brackets at the end of each individual span. The values of m are indicated in Tab 3.

Pt B, Ch 3, Sec 2

The pressure p , in kN/m^2 , and allowable stresses σ_{am} and τ_{am} , in N/mm^2 , are defined in [2.7.2] to [2.7.6] for the various regions of the hull.

These formulae are valid for stiffeners whose web is perpendicular to the plating, or forms an angle to the plating of less than 15° .

In the case of stiffeners whose web forms an angle $\alpha > 15^\circ$ to the perpendicular to the plating, the required modulus and shear area may be obtained from the same formulae, dividing the values of Z and A_f by $\cos \alpha$.

The section modulus of ordinary stiffeners is to be calculated in association with an effective width of plating equal to the spacing of the stiffeners, without exceeding 20 per cent of the span.

The web thickness is to be not less than:

- 1/15 of the depth, for flat bars;
- 1/35 of the depth, for other sections

and the thickness of the face plate is to be not less than 1/20 of its width.

The ends of ordinary stiffeners are, in general, to be connected by means of Rule brackets to effective supporting structures.

Ends without brackets are accepted at the penetrations of primary supporting members or bulkheads by continuous stiffeners, provided that there is sufficient effective welding section between the two elements. Where this condition does not occur, bars may be accepted instead of the brackets, at the discretion of Tasneef.

In general, the resistant weld section A_w , in cm^2 , connecting the ordinary stiffeners to the web of primary members, is not to be less than:

$$A_w = \phi p s \cdot K \cdot 10^{-3}$$

where:

ϕ : coefficient as indicated in Tab 4

p : design pressure, in kN/m^2 , acting on the secondary stiffeners, defined in [2.7.2] to [2.7.6] for various hull regions

s : spacing of ordinary stiffeners, in m

l : span of ordinary stiffeners, in m

K : greater material factor of ordinary stiffener and primary member, defined in Sec 1, [1.6].

For aluminium alloys, when calculating the resistant connecting weld section, the fillet weld length d_e , in mm, is to be determined as follows (see case 1 and 2 in Tab 4):

- case 1: $d_e = d - 20$ where d , in mm, is the length of the weld
- case 2: for extruded T stiffeners, the lesser of $d_e = b - 20$ and $d_e = 4 \cdot t$, where b , in mm, is the flange width of the

ordinary stiffener and t , in mm, is the web thickness of the primary member.

Table 3

Type of stiffener	m
Continuous longitudinal stiffeners without Rule brackets at the ends of span	12
Longitudinal and transverse stiffeners with Rule brackets at the ends of span	19
Longitudinal and transverse stiffeners with Rule brackets at one end of span	15
Non-continuous longitudinal stiffeners and transverse stiffeners without Rule brackets at the ends of span	8

Table 4

Case	Weld	ϕ
1	Parallel to the reaction on primary member	200
2	Perpendicular to the reaction on primary member	160

2.7.2 Bottom and bilge stiffeners (1/5/2023)

Both single and double bottoms are generally to be longitudinally framed.

The section modulus, shear area and welding section required for bottom and bilge stiffeners are given by the formulae in [2.7.1], assuming:

a) p = impact pressure p_{sl} if occurring on the bottom as defined in Ch 2, Sec 2, [4.3], where $\sigma_{am} = 70/K \text{ N/mm}^2$
 $\tau_{am} = 45/K \text{ N/mm}^2$;

b) p = sea pressure p_s defined in Ch 2, Sec 2, [4.5], where:

- stiffeners contributing to the longitudinal strength:

$$\sigma_{am} = 70 \cdot C_A / K \text{ N/mm}^2$$

$$\tau_{am} = 45 / K \text{ N/mm}^2$$

- stiffeners not contributing to the longitudinal strength:

$$\sigma_{am} = 70 / K \text{ N/mm}^2$$

$$\tau_{am} = 45 / K \text{ N/mm}^2$$

where C_A is given by Tab 5 as a function of the distance x , in m, from the calculation point of section modulus to the after perpendicular.

Table 5

x/L	C_A
$x/L < 0,1$	1
$0,1 \leq x/L \leq 0,3$	$1 + 0,5 \cdot \left(0,3 - \frac{1}{e}\right) \cdot \left(10 \cdot \frac{x}{L} - 1\right)$
$0,3 < x/L < 0,7$	$1,3 - \frac{1}{e}$
$0,7 \leq x/L \leq 0,9$	$1 - 0,5 \cdot \left(0,3 - \frac{1}{e}\right) \cdot \left(10 \cdot \frac{x}{L} - 9\right)$
$x/L > 0,9$	1

Note 1: The value of C_A is to be taken less than or equal to 1.

Bottom longitudinals are preferably continuous through the transverse elements. Where they are interrupted at a transverse watertight bulkhead, continuous brackets are to be positioned through the bulkhead so as to connect the ends of longitudinals.

2.7.3 Side and front wall stiffeners

The section modulus, shear area and welding section are given by the formulae in [2.7.1], assuming:

- p = sea pressure p_s as defined in Ch 2, Sec 2, [4.5], for side stiffeners;

- p = sea pressure p_f as defined in Ch 2, Sec 2, [4.6], for front wall stiffeners;

- side stiffeners contributing to the longitudinal strength:

$$\sigma_{am} = 70 \cdot C_A / K \text{ N/mm}^2$$

$$\tau_{am} = 45 / K \text{ N/mm}^2;$$

- side stiffeners not contributing to the longitudinal strength and front wall stiffeners:

$$\sigma_{am} = 70 / K \text{ N/mm}^2$$

$$\tau_{am} = 45 / K \text{ N/mm}^2;$$

where C_A is given by Tab 5 as a function of the distance x , in m, from the calculation point of section modulus to the after perpendicular.

For unprotected front walls located at the fore end, the pressure p_{sf} (see Ch 2, Sec 2, [4.6]) and allowable stresses will be considered individually by Tasneef.

2.7.4 Stiffeners of cross-deck bottom and internal sides of twin-hull vessel

The section modulus, shear area and welding section for bottom stiffeners of the cross-deck are given by the formulae in [2.7.1], assuming:

- a) p = impact pressure p_{si} as defined in Ch 2, Sec 2, [4.4]

$$\sigma_{am} = 85 / K \text{ N/mm}^2$$

$$\tau_{am} = 45 / K \text{ N/mm}^2;$$

- b) p = sea pressure p_s as defined in Ch 2, Sec 2, [4.5],

- stiffeners contributing to the longitudinal strength:

$$\sigma_{am} = 70 \cdot C_A / K \text{ N/mm}^2$$

$$\tau_{am} = 45 / K \text{ N/mm}^2;$$

- stiffeners not contributing to the longitudinal strength:

$$\sigma_{am} = 70 / K \text{ N/mm}^2$$

$$\tau_{am} = 45 / K \text{ N/mm}^2;$$

where C_A is given by Tab 5 as a function of the distance x , in m, from the calculation point of section modulus to the after perpendicular.

Internal side stiffeners may have characteristics intermediate between those of the bottom of the hull and those of the bottom of the cross-deck. In any case, such characteristics are not to be less than those required in [2.7.3] for external sides.

2.7.5 Deck stiffeners

The section modulus, shear area and welding section are given by the formulae in [2.7.1], assuming:

- p = deck pressure p_d as defined in Ch 2, Sec 2, [4.8];

- stiffeners contributing to the longitudinal strength:

$$\sigma_{am} = 70 \cdot C_A / K \text{ N/mm}^2$$

$$\tau_{am} = 45 / K \text{ N/mm}^2;$$

- stiffeners not contributing to the longitudinal strength:

$$\sigma_{am} = 70 / K \text{ N/mm}^2$$

$$\tau_{am} = 45 / K \text{ N/mm}^2;$$

where C_A is given by Tab 5 as a function of the distance x , in m, from the calculation point of section modulus to the after perpendicular.

Where there are concentrated loads of significant magnitude, deck stiffeners are to be adequately strengthened. In particular, stiffeners of decks intended for the carriage of vehicles are to be able to support the concentrated loads transmitted by the wheels, including inertia effects.

In this case, the structural check is, in general, to be carried out adopting the static model of the continuous girder on several supports (formed by primary supporting members) and considering the most severe vehicle loading arrangement for deck stiffeners. The normal and shear stresses thus calculated are not to exceed the allowable limits defined above.

The ordinary stiffeners of decks or flats constituting the top or bottom of tanks are also to comply with the requirements of [2.10].

Where longitudinals are interrupted in way of watertight bulkheads or reinforced transverse structures, the continuity of the structure is to be maintained by means of brackets penetrating the transverse element. Tasneef may allow double brackets welded to the transverse element, provided that special provision is made for the alignment of longitudinals, and full penetration welding is used.

2.7.6 Stiffeners of deckhouse boundary walls

The section modulus, shear area and welding section are given by the formulae in [2.7.1], assuming:

- p = sea pressure p_{su} as defined in Ch 2, Sec 2, [4.7];

$$\sigma_{am} = 70 / K \text{ N/mm}^2$$

$$\tau_{am} = 45 / K \text{ N/mm}^2;$$

If unprotected front walls are located at the fore end, the pressure p_{su} and the allowable stresses will be considered individually by Tasneef.

Any front or side wall vertical stiffeners of first tier deck-houses are to be connected, by means of brackets at the ends, to strengthening structures for decks or adjacent sides.

Longitudinal stiffeners are to be fitted on the upper and lower edges of large openings in the plating. The openings for doors are, in general, to be stiffened all the way round.

Where there is no access from inside deckhouses to 'tween-decks below, or where a deckhouse boundary wall is in a particularly sheltered location, reduced scantlings with respect to those stipulated above may be accepted, at the discretion of Tasneef.

2.8 Primary supporting members

2.8.1 General

This section gives the requirements to be complied with for primary supporting members of the bottom, sides, decks and, for twin-hull vessel, the cross-deck.

The primary supporting members (floors, frames, beams) are to form continuous transverse frames. In general, the stiffened frame spacing, in mm, is not to exceed:

$$1200 + 10 \cdot L$$

without being greater than 2 m.

Primary supporting members with spacing other than that defined above may be required for specific parts of the hull (e.g. machinery space, under pillars) as stipulated in the provisions below.

The section modulus Z , in cm^3 , and shear area A_t , in cm^2 , required to support the design pressure transmitted by the ordinary stiffeners are given by the following formulae:

$$Z = 1000 \cdot \frac{S^2 \cdot b \cdot p}{m \cdot \sigma_{am}}$$

$$A_t = 5 \cdot \frac{S \cdot b \cdot p}{\tau_{am}}$$

where:

m : coefficient which depends on support conditions at the ends of the girder span, generally assumed to be:

- 10, for floors, bottom girders, side frames, deck beams and girders, vertical webs of superstructures;
- 12, for side stringers.

In special circumstances, a different value may be taken for m , at the discretion of Tasneef.

The pressure p , in kN/m^2 , and allowable stresses σ_{am} and τ_{am} , in N/mm^2 , are defined in [2.8.2] to [2.8.6] for various parts of the hull.

The above formulae are applicable where reinforced structures are not of the grillage type. Otherwise, the scantlings of reinforced structures will be stipulated by means of direct calculations performed on the basis of criteria agreed upon with Tasneef.

The section modulus of primary supporting members is to be calculated in association with attached plating, according to criteria specified by Tasneef.

For steel stiffeners, the following geometric ratios are to be satisfied:

- the web thickness is to be not less than 1/80 of web depth;
- the face plate thickness is to be not less than 1/30 of face plate breadth (1/15 for face plates which are not symmetrical with respect to the web).

2.8.2 Floors and girders of single bottom

The section modulus and shear area are given by the formulae in [2.8.1], for the following two conditions:

a) p = impact pressure p_{si} if occurring on the bottom as defined in Ch 2, Sec 2, [4.3] (when slamming on the bottom occurs), where: $\sigma_{am} = 70/K \text{ N/mm}^2$
 $\tau_{am} = 45/K \text{ N/mm}^2$;

b) p = sea pressure p_s as defined in Ch 2, Sec 2, [4.5], where:

- aluminium alloy floors:

$$\sigma_{am} = 70/K \text{ N/mm}^2$$

$$\tau_{am} = 45/K \text{ N/mm}^2$$

- aluminium alloy girders:

$$\sigma_{am} = 70 \cdot C_A/K \text{ N/mm}^2$$

$$\tau_{am} = 45/K \text{ N/mm}^2$$

where C_s and C_A are given by Tab 5 as a function of the distance x , in m, from the calculation point of section modulus to the after perpendicular.

Floors are to be positioned in way of side and deck transverses. Intermediate floors may also be fitted provided that they are adequately connected at the ends.

Manholes and other openings are not to be located at the ends of floor or girder spans, unless shear stress checks are carried out in such areas.

Floors are to be fitted in machinery spaces, generally at every frame, and additional stiffeners are to be provided in way of machinery and pillars.

In way of main machinery seatings, girders are to be positioned extending from the bottom to the foundation plate of main engines.

A girder is generally to be fitted centreline for dry-docking. The height of such a girder is to be not less than that of floors amidvessels and the thickness not less than the value t , in mm, obtained from the formula:

$$t = (0,07 \cdot L + 2,5) \cdot K^{0,5}$$

The girder is to be fitted with a continuous face plate above the floors, its area not less than the value A_p , in cm^2 , given by:

$$A_p = 0,5 \cdot L \cdot K$$

In hulls with a longitudinally framed bottom and width $B > 8$ m, side girders are also to be positioned in such a way as to divide the floor span into approximately equal parts. In twin-hull vessel, B is to be taken as the width of a single-hull. The thickness of the web may be assumed to be equal to that of the centre girder less 1 mm, and the area of the

face plate may be reduced to 60% of that of the centre girder. Where side girders are intended to support floors, a structural check of their scantlings is to be carried out as deemed necessary by Tasneef.

2.8.3 Primary supporting members of sides and front walls

The section modulus and shear area are given by the formulae in [2.8.1], assuming:

- p = sea pressure p_s as defined in Ch 2, Sec 2, [4.5], for primary members of sides;
- p = sea pressure p_{sf} as defined in Ch 2, Sec 2, [4.6], for primary members of front walls;

$$\sigma_{am} = 70/K - \sigma_a \text{ N/mm}^2;$$

$$\tau_{am} = 45/K \text{ N/mm}^2;$$

σ_a is the stress induced by the normal force in side transverses due to deck loads transmitted by deck beams.

For unprotected front walls located at the fore end, the pressure p_{sf} (see Ch 2, Sec 2, [4.6]) and allowable stresses will be considered individually by Tasneef.

2.8.4 Primary supporting members of the cross-deck and internal sides of twin-hull vessel

In the most common case of cross-deck structures constituted by transverse stiffener plates enclosed between lower plating and a deck, and connected at the ends to reinforced hull structures, the scantlings are determined by transverse strength checks aimed at ensuring an adequate connection between the hulls (see [2.4]).

Where the cross-deck is formed by multiple structures, each of the latter is also to be checked for the effect of local loads, in accordance with the following provisions.

The section modulus and shear area required for transverse structures of the cross-deck are given by the formulae in [2.8.1], for the following two conditions:

a) lower structures of the cross-deck:

- p = impact pressure p_{si} as defined in Ch 2, Sec 2, [4.4]:

$$\sigma_{am} = 85/K \text{ N/mm}^2;$$

$$\tau_{am} = 45/K \text{ N/mm}^2;$$

b) cross-deck structures supporting decks:

- p = deck pressure p_d as defined in Ch 2, Sec 2, [4.8];

$$\sigma_{am} = 70/K \text{ N/mm}^2;$$

$$\tau_{am} = 45/K \text{ N/mm}^2;$$

Where the lower structure of the cross-deck also supports a deck, such a structure is to be checked separately for conditions (a) and (b).

The section modulus and shear area required for side transverses of internal sides are given by the formulae in [2.8.1], for condition (a) above.

2.8.5 Primary supporting members of decks

In the absence of concentrated loads transmitted to the primary supporting member by pillars or other primary supporting members, the section modulus and shear area required for deck transverses and deck girders supporting

longitudinals and beams, respectively, are given by the formulae in [2.8.1], assuming:

- p = deck pressure p_d as defined in Ch 2, Sec 2, [4.8];
- steel deck transverses:

$$\sigma_{am} = 70/K \text{ N/mm}^2;$$

$$\tau_{am} = 45/K \text{ N/mm}^2;$$

- aluminium alloy deck transverses:

$$\sigma_{am} = 70 \cdot C_A/K \text{ N/mm}^2;$$

$$\tau_{am} = 45/K \text{ N/mm}^2;$$

where C_s and C_A are given by Tab 5 as a function of the distance x , in m, from the calculation point of section modulus to the after perpendicular.

The primary members of decks or flats constituting the top or bottom of tanks are also to comply with the requirements of [2.10].

When there are concentrated loads of significant magnitude (e.g. transmitted by pillars or other primary members or due to the carriage of vehicles), deck girders are to be adequately strengthened.

In this case the structural check is generally to be carried out by using the static model of a beam with partial clamping at its ends (clamping coefficient = 0,30).

The allowable stresses stipulated above are to be considered.

The beam section is to be kept constant over its length.

At the discretion of Tasneef, calculations based on different static models may be accepted, depending on the structural typology adopted.

2.8.6 Primary supporting members of deckhouse boundary walls

The section modulus and shear area are given by the formulae in [2.8.1], assuming:

- p = see pressure p_{su} as defined in Ch 2, Sec 2, [4.7];

$$\sigma_{am} = 70/K \text{ N/mm}^2;$$

$$\tau_{am} = 45/K \text{ N/mm}^2;$$

For unprotected front walls located at the fore end, the pressure p_{su} and allowable stresses will be considered individually by Tasneef.

Where there is no access from inside deckhouses to 'tween-decks below or where a deckhouse boundary wall is in a particularly sheltered location, reduced scantlings with respect to those stipulated above may be accepted at the discretion of Tasneef.

2.9 Pillars made of aluminium alloys

2.9.1 Loads on pillars

Where pillars are aligned, the compressive load Q , in kN, is equal to the sum of loads supported by the pillar considered and those supported by the pillars located above, multiplied by a weighting factor.

The weighting factor depends on the relative position of each pillar with respect to that considered.

This coefficient is equal to:

- 1,000, for the pillar considered
- 0,9, for the pillar immediately above (first pillar of the line)
- $0,810 = (0,9)^2$, for the following pillar (second pillar of the line)
- $0,729 = (0,9)^3$, for the third pillar of the line
- in general, $(0,9)^n$, for the pillar of the n^{th} line, but not less than $(0,9)^7 = 0,478$.

2.9.2 Critical stress for overall buckling of pillars

For global buckling behaviour of pillars made of aluminium alloy, the critical stress, σ_c , in N/mm², is given by the formula:

$$\sigma_c = \frac{\eta \cdot R_{p0,2}}{0,85 + 0,25 \cdot \left(\frac{f \cdot l}{r}\right)} \cdot C$$

where:

η : joint coefficient for the welded assembly, as given in Sec 1, [1.6]

$R_{p0,2}$: minimum guaranteed yield stress of aluminium alloy used, in N/mm², in delivery condition

C : coefficient as given in Fig 5:

$$\frac{1}{1 + \lambda + [(1 + \lambda)^2 - 0,68 \cdot \lambda]^{0,5}}$$

for alloys without heat treatment

$$\frac{1}{1 + \lambda + [(1 + \lambda)^2 - 3,2 \cdot \lambda]^{0,5}}$$

for alloys with heat treatment

λ : $\frac{\eta \cdot R_{p0,2}}{\sigma_E}$

σ_E : $\frac{69,1}{(f \cdot l/r)^2}$

l : length of pillar, in m

r : $\left(\frac{I}{A}\right)^{0,5}$

, minimum radius of gyration, in cm, of the pillar cross-section

I : minimum moment of inertia, in cm⁴, of the pillar cross-section

A : area, in cm², of the pillar cross-section

f : coefficient given in Fig 7 depending on the conditions of fixing of the pillar.

2.9.3 Critical stress for local buckling of pillars

For local buckling behaviour of pillars made of aluminium alloy, the admissible stress σ_{cl} , in N/mm², is given by the formula:

$$\sigma_{cl} = 2 \cdot \eta \cdot R_{p0,2} \cdot C$$

where:

C : coefficient as defined in previous item

λ : $\frac{\eta \cdot R_{p0,2}}{\sigma_{EI}}$

η : joint coefficient for the welded assembly, as defined in Sec 1, [1.6].

σ_{EI} : stress defined below.

For tubular pillars with a rectangular cross-section, the stress σ_{EI} , in N/mm², is given by:

$$\sigma_{EI} = 252000 \cdot \left(\frac{t}{b}\right)^2$$

where:

b : greatest dimension of the cross-section, in mm

t : plating thickness, in mm.

For tubular pillars with a circular cross-section, the stress σ_{EI} , in N/mm², is given by:

$$\sigma_{EI} = 43000 \cdot \frac{t}{D}$$

where:

D : outer diameter, in mm,

t : plating thickness, in mm.

For pillars with T cross-sections, the stress, σ_{EI} , in N/mm², is the lesser of the following values:

$$\sigma_{EI} = 252000 \cdot \left(\frac{t_w}{h_w}\right)^2$$

$$\sigma_{EI} = 105000 \cdot \left(\frac{t_f}{b_f}\right)^2$$

where:

t_w : web thickness, in mm,

h_w : web height, in mm,

t_f : thickness of face plate, in mm,

b_f : width of face plate, in mm.

Figure 5

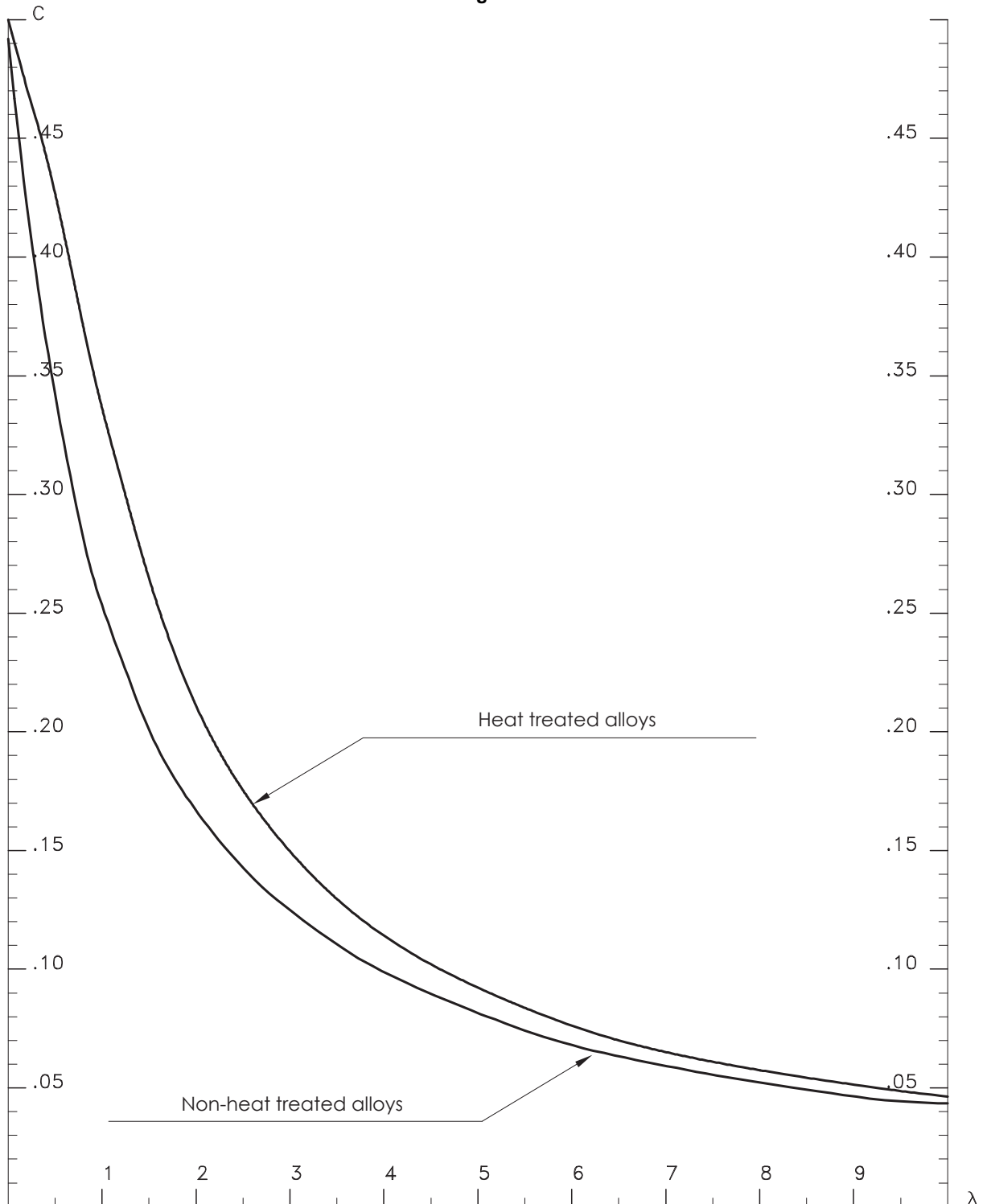

2.9.4 Scantlings of pillars

The scantlings of pillars are to comply with the following requirements:

$$\sigma \leq \sigma_c$$

$$\sigma \leq \sigma_{cl}$$

where:

σ : $10 \cdot Q/A$, compressive stress, in N/mm², in the pillar due to load **Q**, **A** being the cross-sectional area, in cm², of the pillars

σ_c : overall buckling critical stress, as defined in [2.9.2]

σ_{cl} : local buckling critical stress, as defined in [2.9.3]

The maximum allowable axial load, in kN, is the smaller of the following values:

$$P_c = \sigma_c \cdot A \cdot 10^{-1}$$

$$P_{cl} = \sigma_{cl} \cdot A \cdot 10^{-1}$$

2.10 Tank bulkheads

2.10.1 General

Hollow profiles are not permitted as tank walls or in tanks for flammable liquids.

2.10.2 Plating

The required thickness, in mm, is given by the formula:

$$t = 22,4 \cdot f_m \cdot \mu \cdot s \cdot \left(\frac{p_t}{\sigma_{am}} \right)^{0,5}$$

where:

f_m : coefficient depending on the material equal to 0,75

p_t : design pressure, in kN/m², as defined in Ch 2, Sec 2, [4.9]

σ_{am} : 85/K N/mm².

2.10.3 Ordinary stiffeners

The section modulus, shear area and welding section required for ordinary stiffeners are given by the formulae in [2.7.1], assuming:

p : design pressure p_t as defined in Ch 2, Sec 2, [4.9]

m : coefficient depending on the type of stiffener and support conditions at the ends of the stiffener span, to be taken according to Tab 3

$$\sigma_{am} = 70/K \text{ N/mm}^2$$

$$\tau_{am} = 45/K \text{ N/mm}^2$$

2.10.4 Primary supporting members

The section modulus, shear area and welding section required for horizontal and vertical girders are given by the formulae in [2.8.1] assuming:

p : design pressure p_t as defined in Ch 2, Sec 2, [4.9]

m : coefficient depending on support conditions at the ends of the girder span, generally to be taken equal to 10

$$\sigma_{am} = 70/K \text{ N/mm}^2$$

$$\tau_{am} = 45/K \text{ N/mm}^2$$

2.10.5 Corrugated bulkheads

The thickness and section modulus of corrugated bulkheads, calculated as stated in [2.10.2], [2.10.3] and [2.10.4] are to be increased by 10% and 20%, respectively

The section modulus W_c , in cm³, of a corrugation may be derived from the following formula:

$$W_c = d \cdot t \cdot (3 \cdot b + c) / 6000$$

where the symbols are as shown in Fig 7 and are expressed in mm. In no case is the angle ϕ to be less than 40°.

2.11 Subdivision bulkheads

2.11.1 Plating

The required thickness, in mm, is given by the formula:

$$t = 22,4 \cdot f_m \cdot \mu \cdot s \cdot \left(\frac{p_{sb}}{\sigma_{am}} \right)^{0,5}$$

where:

f_m : coefficient depending on the material equal to 0,70

p_{sb} : design pressure, in kN/mm², as defined in Ch 2, Sec 2, [4.10]

σ_{am} : 95/K N/mm²

The thickness of the collision bulkhead is to be calculated from the formula given above, multiplied by 1,15.

2.11.2 Ordinary stiffeners

The section modulus, shear area and welding section required for ordinary stiffeners are given by the formulae in [2.7.1], assuming:

p : design pressure p_{sb} as defined in Ch 2, Sec 2, [4.10]

m : coefficient depending on the type of stiffener and support conditions at the ends of the stiffener span, to be taken according to Tab 3

$$\sigma_{am} = 95/K \text{ N/mm}^2$$

$$\tau_{am} = 55/K \text{ N/mm}^2$$

The section modulus, shear area and welding section required for the ordinary stiffeners of the collision bulkhead are to be calculated as above, considering σ_{am} and τ_{am} divided, respectively, by 1.15 and 1.05.

2.11.3 Primary supporting members

The section modulus, shear area and welding section required for horizontal and vertical girders are given by the formulae in [2.8.1], assuming:

p : design pressure p_{sb} as defined in Ch 2, Sec 2, [4.10]

m : coefficient depending on support conditions at the ends of the girder span, generally to be taken equal to 10

$$\sigma_{am} = 95/K \text{ N/mm}^2$$

$$\tau_{am} = 55/K \text{ N/mm}^2$$

The section modulus, shear area and welding section required for the primary supporting members of the collision bulkhead are to be calculated as above, considering σ_{am} and τ_{am} divided, respectively, by 1,3 and 1,2.

2.11.4 Corrugated bulkheads

The thickness and section modulus of corrugated bulkheads, calculated as stated in [2.11.1], [2.11.2] and [2.11.3] are to be increased by 10% and 20%, respectively.

The section modulus of a corrugation is to be calculated as indicated in [2.10.5].

2.12 Non-tight bulkheads

2.12.1 The thickness of plating of non-tight bulkheads which do not act as pillars is to be not less than 2 mm for

steel bulkheads, and 3 mm for aluminium alloy bulkheads, and vertical stiffeners are to be not more than 900 mm apart.

Vertical stiffeners are to have a section modulus (calculated in association with a width of plating equal to the stiffener spacing but not exceeding 750 mm) not less than the value, in cm³ given by the formula:

$$Z = 2 \cdot s \cdot S^2$$

The thickness of plating of non-tight bulkheads which act as pillars is to be not less than 2 mm for steel bulkheads, and 3 mm for aluminium alloy bulkheads, and vertical stiffeners are to be not more than 750 mm apart.

Vertical stiffeners are to have a section modulus (calculated in association with a width of plating equal to the stiffener spacing but not exceeding 750 mm) not less than the value, in cm³ given by the formula:

$$Z = 0,265 \cdot s \cdot S^2$$

In addition, each vertical stiffener, in association with a width of plating equal to 50 times the plating thickness, is to comply with the requirements for pillars given in [2.9], the load supported being determined in accordance with the same provisions.

In the case of tanks extending from side to side, a wash bulkhead is generally to be fitted amidvessels; with plating thickness not less than 3 mm and strengthened by vertical stiffeners.

2.13 Independent prismatic tanks

2.13.1 The required thickness for the plating of independent prismatic tanks, in mm, is given by the formula:

$$t = 1,25 \cdot f_m \cdot \mu \cdot p_t \cdot K^{0,5}$$

where:

f_m : coefficient depending on the material, equal to 1,45

p_t : design pressure, in kN/mm², as defined in Ch 2, Sec 2, [4.9]

In no case is the thickness to be less than 3,5 mm.

The section modulus required for stiffeners, in cm³, is given by the formula:

$$Z = 0,4 \cdot f_m \cdot s \cdot l^2 \cdot p_t \cdot K$$

where:

f_m : coefficient depending on the material, equal to 2,15.

The connections to reinforced hull structures of independent tanks are to be able to withstand the dynamic loads induced by the tank weight and the acceleration a_v of the vessel (see Ch 2, Sec 2, [2]).

It is recommended that stiffener plates should be arranged so as to prevent undue movement of the liquid.

Figure 6

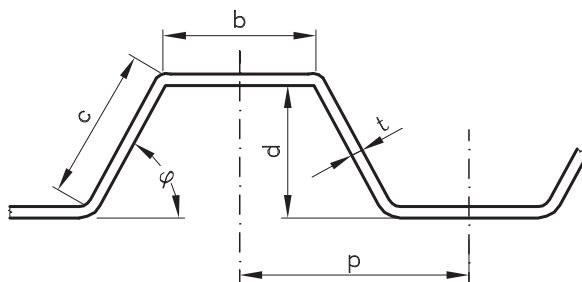
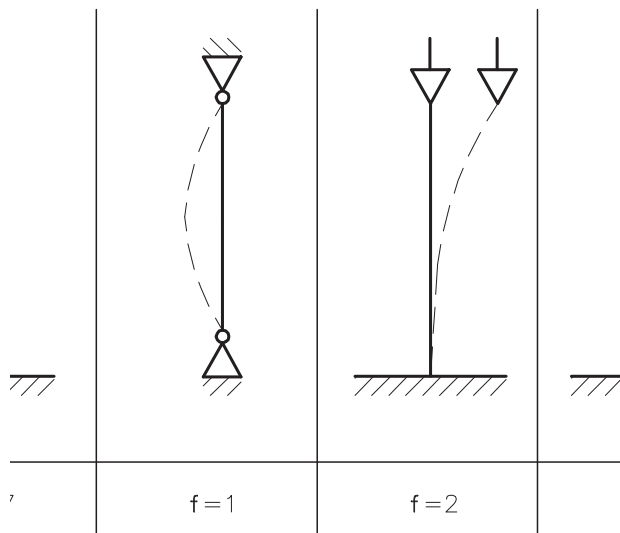

Figure 7



Part B
Hull and Stability

Chapter 4
STABILITY

SECTION 1 GENERAL REQUIREMENTS

SECTION 1

GENERAL REQUIREMENTS

1 Documentation to be submitted and general requirements

1.1 Documentation to be submitted

1.1.1

The following documentation shall be submitted for approval:

- stability manual
- inclining test report (when required)
- weathertight integrity plan
- freeboard calculation

The following documentation is assumed for information:

- general arrangement
- body/lines plan

In general the requirements of Part B, Chapter 3 of the Rules apply with the relaxations/alternatives reported in this section.

For vessel required to be arranged with buoyancy elements, the capability in flooded condition shall be documented and verified by full scale test. Enclosed superstructure, deckhouses and trunks may be included as buoyancy elements provided they have approved strength and watertight closing appliances.

Buoyancy elements may consist of foam, prefabricated or formed in position (in-situ), or tanks and double hull filled with air or buoyancy elements. Buoyancy elements must be fixed or permanently fitted and protected against mechanical damage and degradation from the environment; drainage shall be arranged for enclosed spaces used for buoyancy element. Such spaces shall normally not be used for storage or other scopes.

For vessel with fenders along the sides of the hull the fenders may be included when calculating the stability of the vessel subject to agreement with the Society. This applies to fenders that are secured or bonded to the hull such that they will not be dislodged when submerged. Fenders shall be solid or may be of foam filled construction in which case the foam shall be bonded to the hull such that it will not be dislodged when submerged.

Marks for maximum draught are to be arranged only at bow and stern.

For vessel with length L less than 6 m, and vessels arranged with buoyancy, the ordinary inclining test may be replaced by a full scale stability test.

Permanent heel or trim which may generate danger for accumulation of water on deck is not accepted.

Ballast is generally acceptable provided that it is documented and installed as prescribed by Tasneef Rules and good practice.

1.2 General Requirements

1.2.1

No damage stability calculation is required. Anyway Flag Administration may requires for damage stability calculation or similar cases.

1.2.2

For intact stability in general the requirements of Part B, Chapter 3 of the Rules apply with the relaxations/alternatives reported in this section.

1.2.3

In case of vessels where buoyancy elements are required, it is to be verified with a practical full scale test the stability with the buoyant element flooded,

If of adequate strength and watertight means of closure enclosed superstructure, trunks, deckhouses or similar structures may be considered elements of buoyancy.

Buoyancy elements may consist of foam, prefabricated or not or may be tanks, void spaces or double hull filled with air or buoyancy elements.

Buoyancy elements must be strongly fixed or permanently fitted and protected against damages and degradation from the environment.

Systems to drain enclosed spaces used for buoyancy element have to be provided and nothing is to be stored in such spaces.

1.2.4

Fenders located on the sides may be considered elements of buoyancy if agreed with Tasneef.

Such fenders are to be solid, filled with foam and fixed to the hull so that they remain in place when the vessel is flooded.

1.2.5

For vessel with $L < 6$ m and vessels arranged with buoyancy, the ordinary inclining test may be replaced by a full scale stability test.

1.2.6

Permanent heel or trim which may generate danger for accumulation of water on deck is not accepted.

1.2.7

Ballast is generally acceptable provided that it is documented and installed as prescribed by Tasneef Rules and good practice.

1.2.8

Marks for maximum draught are to be arranged only at bow and stern.

2 Freeboard

2.1 Decked vessel

2.1.1

For decked vessel the minimum freeboard is to be at least 0.2m. The platform height at stem normally is to be nowhere less than 0.12 L above deepest waterline. Such height may be reduced up to the level of freeboard deck at 0.25 L from the stem and afterwards.

Tasneef may evaluate reduction at stem.

2.2 Open vessel

2.2.1

The mean freeboard, F, in mm, is to be not less than:

$$F = \frac{4,5\Delta}{1000LB}$$

or $F_{\min} = 500$ mm

If what above is not satisfied in the vessel buoyancy elements have to be installed.

2.2.2

For vessel arranged with buoyancy elements, the mean freeboard, F, is to be not less than:

$F = 200 B$ mm

or

$F_{\min} = 200$ mm

2.2.3

On vessels the freeboard aft is to be not less than:

$F_{\text{aft}} = 0.8 F$

3 Stability Requirements

3.1 Decked vessel

3.1.1

In general the requirements of Part B, Chapter 3 of the Rules apply. As alternative what follows may be applied:

The following conditions are to be considered:

- Lightship with minimum equipment and cargo. Combined loads are not to exceed 10% of maximum load capacity.
- Loaded with maximum equipment and cargo in holds and on deck. Combined loads are not to be less than 90% of maximum load capacity in the mode of departure and arrival.
- Deck load with maximum equipment and cargo on deck and empty holds in the mode of departure and arrival.
- Other relevant conditions, where necessary.

3.1.2

Crowding of persons at one side: In maximum load condition the vessel shall not capsize or be flooded if all persons moves to the sameside, the angle of heel shall not exceed 10°, caused by a heeling weight of at least:

$P = 82.5 n$ (kg)

where n = total number of persons.

with the weight located 1 m above deck along the gunwale.

3.1.3

For the calculation of the heeling moment due to operation of lifting gear and similar appliances it is to be considered a dynamic factor of 1.4. The angle of heel is to be less than 10° for maximum moment in the most unfavourable condition.

In the condition stated in [3.1.1] the followings criteria have to be satisfied:

- The righting arm at 30° heel shall be minimum 0.20 metres
- The maximum value of the GZ-curve shall occur at an angle not smaller than 25°
- The GZ curve shall normally be positive up to 50° of heel.

3.2 Open vessel

3.2.1

One of the following criteria may be applied:

- An inclining test is to be carried out to define the meta-centric height GM in lightship condition. GM is to be more than 0.50 m, or
- The inclining test may be omitted if it for the load condition can be demonstrated that the period of roll in seconds (from one side and back to the same side) is less or equal to the vessel beam in meters, or
- The GZ curves satisfy the requirements for Decked vessel up to an angle of heel of at least 30°, and
- Crowding of persons at one side as described for decked vessel.

3.3 Open vessel with buoyancy

3.3.1 Stability in intact condition

In lightweight condition the vessel is not to be flooded, or the angle of heel does not exceed 10°, for a heeling weight of:

$P = 22 \times n$ (kg) (n = number of persons),

or

$P_{\min} = 44$ (kg).

with the weight placed at the gunwale at the maximum beam of the vessel, and not less than $B_{\max}/2$ from the centreline.

The requirements in case of the crowding of person at one side is to be satisfied with the weight be located on the floor as near to the gunwale as possible, but minimum $B_{\max}/4$ from centreline and with longitudinal position corresponding to the arrangement of the accommodation. Weights representing equipment shall be located at their locations.

3.3.2 Buoyancy in flooded condition

In maximum load condition including any outboard engine the flooded vessel is to float reasonably horizontally and not sink when loaded with additional weight:

$P = 27.5 \times n$ (kg) (n = total number of persons),

but not less than:

$$P = 55 + 55 (L - 2.5) \text{ (kg)},$$

or

$$P_{\min} = 82.5 \text{ (kg)}.$$

Weights shall be located at their locations on board.

3.3.3 Stability in flooded condition

In maximum load condition including any outboard engine the flooded vessel is to have a positive stability up to at least 50° of heel when loaded with an additional weight located anywhere along the gunwale:

$$P_K = 11 + 5.5 \times n \text{ (kg)} \text{ (n = total number of persons)},$$

or

$$P_{K\min} = 27.5 \text{ (kg)}.$$

3.4 Stability of Small Tugs

3.4.1 (1/1/2025)

Units having the additional service feature "Small Tug" are to have an initial metacentric height GM, in m, corrected according to Pt B, Ch 3, Sec 2, [4.7] of the Rules, which - in the most severe condition - is not to be less than the value obtained from the following formula:

$$GM = \frac{66 \cdot T \cdot h \cdot B}{f \cdot \Delta}$$

where:

B: ship's maximum breadth, in m

f: ship's freeboard, in mm, to be assumed not greater than 650 mm

T: Maximum towing pull, in kN. To be assumed, whenever unknown, equal to:

- T = 0,179 P for propellers not fitted with nozzles
- T = 0,228 P for propellers fitted with nozzles.

h: vertical distance, in m, between the towing hook, or equivalent fitting, and half draught at midship corresponding to Δ

Δ : loading condition displacement, in tons.

4 Freeing ports and recesses

4.1 Freeing ports

4.1.1

Freeing ports on decked vessel have to be provided along the deck, with lower edge preferably flush with deck level in any case of not more than 150mm from the deck.

On vessel with bulwark, forecastle, deckhouse or open structures forming wells or recesses, the total freeing port area on each side of the deck is to be minimum $A = 0.02 V \text{ m}^2$ where the volume is the net volume up to the top the bulwark.

Means to block the flaps or reducing the effective area are not allowed.

If the freeing port has a height of more than 330mm horizontal interruption have to be fitted, the maximum distance

from the flush deck and the horizontal interruption is to be not more than 230mm.

4.2 Drainage

4.2.1

On open vessel drainage of deck have to be provided on each side of the vessel to the bilge or directly overboard with a non-return valve.

The area of drainage shall be minimum $A = 0.01 V \text{ m}^2$, where V is the volume as defined in [4.1.1].

5 Weathertight integrity

5.1

5.1.1

Watertight closing appliances have to be provided on paces below the freeboard deck or contributing to the reserve of buoyancy.

Closing appliances are to have the same strength of the surrounding structure.

Other openings giving access to the interior have to be provided with weathertight means of closure.

Weather tight appliances is to be tested with a water jet test.

Hatches which may be opened at sea have to be hinged or attached and being capable of being secured in open position.

Hatch coamings are to be at least 380 mm. For hatches located at least 380 mm above freeboard deck the coaming height may be reduced to 150mm.

Flush hatches on the deck may be accepted if watertight and normally closed when at sea. Flush hatches located at the top of the superstructure or the deckhouse can be opened during the operation at sea and need to be only weathertight.

The hatches that are required to be weathertight has to be subject to a water jet test, and those that have to be watertight to hydrostatic test.

5.1.2

Doors have to be operable from either side of the bulkhead without keys or other tools if they are in the way of escape.

The sill height of door openings to spaces below freeboard deck is to be at least 380 mm. For doors located at least 380 mm above freeboard deck, a reduced height of sill may be accepted, but normally not less than minimum 150 mm.

5.1.3

Arrangement for removable washboard replacing a sill may be accepted based on special consideration.

Port and ramps have to be watertight, the arrangement for safety of operation, stop arrangement and any indicators etc. are to be submitted for approval and the lower edge of openings shall not be less than 200 mm above deepest waterline.

5.1.4

Ventilation openings have to be arranged so that they have minimum height 600 mm above freeboard deck and have not be immersed at heel angle smaller than 50°.

5.1.5

Air pipes have not to exceed diameter of 50 mm, they have to be provided with non-return valve or goose necks to prevent water ingress.

The height of air pipes shall normally not be smaller than 600 mm above the freeboard deck and have to be protected from damage from work on deck.

5.1.6

For windows on deckhouses and portlights in the hull alternatively ISO 12216 or ISO 11336-1 may be applied.

HIGH DENSITY POLYETHYLENE HULLS

- SECTION 1 DESIGN PRINCIPLES AND STABILITY**
- SECTION 2 MATERIALS, CONNECTIONS AND STRUCTURE DESIGN PRINCIPLES**
- SECTION 3 DESIGN LOADS AND HULL SCANTLING**
- SECTION 4 HULL OUTFITTING**
- SECTION 5 RUDDERS, EQUIPMENT AND TESTING**

SECTION 1

DESIGN PRINCIPLES AND STABILITY

1 Application

1.1

1.1.1 (1/5/2023)

The requirements in Ch 1, Sec 1 and Ch 4, Sec 1 apply.

SECTION 2

MATERIALS, CONNECTIONS AND STRUCTURE DESIGN PRINCIPLES

1 Materials and connections

Table 1 (1/5/2023)

Mechanical properties	Value
Density g/cm ³ (acc. to ISO 1183-2)	0.946
Elasticity (Young) modulus at yield (MPa)	E = 950
Shear modulus at yield (MPa)	300
Tensile stress at yield (MPa)	R _{eh} = 22
Tensile stress at Breaking (MPa)	R _m = 30
Tensile elongation at yield (%)	13
Shear stress at yield (MPa)	τ _{eh} = 14
Poisson's coefficient	0.45
Long term service temperature (°C)	80

1.1 General requirements

1.1.1 (1/5/2023)

Materials to be used in hull and equipment construction, in delivery condition, are to comply with these requirements or with specific requirements applicable: they are to be tested in compliance with the applicable provisions. Quality and testing requirements for materials covered here are outlined in the relevant Tasneef Rules.

Welding processes are to be approved for which they are intended and with limits and conditions as stated in the applicable in the relevant Tasneef Rules.

1.2 HDPE hull structures

1.2.1 (1/5/2023)

HDPE is a thermoplastic material made up of long-chain of molecules (polymer) consisting of a series of small repeating molecular units (monomers).

HDPE is characterized by a good impact resistance, light weight, and very low moisture absorption.

HDPE members used for the construction of the hull are not to be of a recycled manufacturing.

Taking into account the non-linearity of the HDPE behavior as shown on Fig 1, the main mechanical characteristics to be considered in the present Section are to be defined by the manufacturer and verified by mechanical tests at the yield limit of the material.

Figure 1 : Stress / elongation curve (1/5/2023)

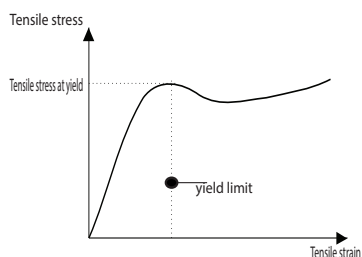

When the mechanical properties of HDPE have not been defined by the manufacture yet, the minimum values at the yield limit are given below, subject to the subsequent confirmation by mechanical tests.

Minimum mechanical characteristics of HDPE is to be verified by testing with the recognized standards e.g. ASTM/ISO or alternatively national standard may be applied, subject to the agreement of Tasneef.

1.2.2 (1/5/2023)

Water absorption of HDPE sheets are to be determined in accordance with ASTM D570-98 or ISO 62:2008 and it is to be in range 0.01 to 0.017 % (24 hrs).

1.2.3 Welded connections (1/5/2023)

A welding booklet, including the weld scantling such as throat thickness and design of joint, is to be submitted to the Society for examination. The welding booklet is not required if the structure drawings submitted to the Society contain the necessary relevant data defining the weld scantling.

The structures of the hull will be in general connected with welded joints as follows.

Butt weld: As a rule, butt welding is to be used for plate and stiffener butts and is mandatory for heavily stressed butts such as those of the bottom, keel, side shell, sheerstrake and strength deck plating, and bulkheads (in particular bulkheads located in areas where vibrations occur). As a rule, the structural butt joints are to be full penetration welds, performed from both sides.

Fillet welds: As a rule, double continuous fillet welds are to be provided. The total throat thickness weld is not to be less than the thinner plate of the assembly.

Other throat thickness may be considered on a case-by-case basis by the Society.

1.2.4 Non Destructive Testing (NDT) of welding (1/5/2023)

The non-destructive testing, their extent and their result acceptance criteria are to be defined by the shipyard and to be submitted to the Society for information.

1.2.5 Welding procedure and Welder certification (1/5/2023)

Welding procedure relating to joints between structural reinforcements and panels and panels between them, reference is to be made to specific procedure to be prepared by the yard and to be made available to attending surveyor before production of the hull. Based on the procedures welders must be certified according to UNI EN 13067 or other recognized standards.

2 Structure design principles

2.1 Protection against high temperature

2.1.1 (1/5/2023)

The Shipyard shall take all the precautions to protect the material against temperatures higher than long term service temperature at the construction stage.

The reason is that HDPE mechanical properties (e.g. tensile stress at yield) degrade dramatically with the increase of the temperature.

Examples of the possible precautions to be taken are:

- a) The engine room is to be fitted with a mechanical ventilation system having a rate capable of keeping the temperature lower than the long-term service temperature.
- b) A system for the washing/cooling of the deck and of the structures particularly exposed to the sun.

2.2 Rounding-off

2.2.1 (1/5/2023)

Values for thickness as obtained from formulae are to be rounded off to the nearest standard value, without such a reduction exceeding 3 per cent.

SECTION 3

DESIGN LOADS AND HULL SCANTLING

1 Application

1.1

1.1.1 (1/5/2023)

The requirements in Ch 2, Sec 2, [2], [3] and [4] apply taking into account the local load point location defined in Ch 2, Sec 2, [4.2.2] (Load points).

For the purpose of defining the value of the parameter "S", as specified in Ch 2, Sec 2, [2.1], the type of service to be adopted is to be in all cases "pilot", except when the unit is intended for rescue operations for which the relevant type of service is to be selected.

The operational area to be considered for the service of the units is not to be more extended than that corresponding to "Moderate environment service".

For limit operating conditions allowed for by design parameters, see Ch 2, Sec 2, [2.4].

2 Hull scantlings

2.1 Introduction

2.1.1 (1/5/2023)

This Article stipulates requirements for the scantlings of hull structures (plating, stiffeners, primary supporting members) made, totally or partly, of high-density polyethylene (HDPE) for building based on HDPE sheets. The loads acting on such structures are to be calculated in accordance with the provisions of [1].

In general, HDPE is not to be used for hull structures of ships more than 24 m in length.

In specific cases the designer may decide to use HDPE for hull structures of ships up to 65 m in length, provided that the following additional requirements are fulfilled:

- Hull girder yielding strength is checked according to [3.2].
- Buckling strength is checked according to [3.3].
- Overall stiffness of the hull girder is checked according to [3.4].

For transverse structures of the hull, *Tasneef* may, at its discretion, and as an alternative to the requirements of this Chapter, accept scantlings based on direct calculations.

2.1.2 Equivalence (1/5/2023)

Structural checks of the hull scantlings may be also carried out in compliance with the provisions of ISO 12215-5 for metallic materials. The design category is not to be greater than C and the safety coefficient to be adopted for the definition of the design stresses is 1.5.

2.1.3 General material approach (1/5/2023)

The scantling formulae will use the yield characteristics of the HDPE (stresses and moduli). The main mechanical characteristics at yield to be defined by the HDPE supplier are the:

- E: tensile modulus of elasticity
- R_{eh} : minimum tensile stress at yield
- τ_{eh} : minimum shear stress at yield
- R_m : minimum tensile stress at breaking
- Long term service temperature
- Elongation.

The minimum mechanical characteristics of HDPE are given in Sec 2, Tab 1. Particular attention is to be taken to avoid the use of HDPE where temperatures may be higher than long term service temperature.

2.1.4 Hull structure scantling analysis (1/5/2023)

The hull structure scantling analysis is to be carried out according to the requirements for aluminum in Ch 3, Sec 2, [2.6] to [2.8], [2.10] and [2.11] as applicable, with the modifications described in [2.1.5] to [2.1.8]. Reference is also made to the description of aluminum strength characteristics in Ch 3, Sec 1, [1.6].

2.1.5 Modifications to be adopted with respect to the strength approach for aluminum, when HDPE is used - General (1/5/2023)

In general, the following modifications are to be adopted in the definitions:

E : tensile modulus of elasticity for HDPE in MPa (see [2.1.5] to [2.1.8])

$$R_{p02} = R_{eh}$$

where R_{eh} is the value for HDPE (see [2.1.5] to [2.1.8]).

2.1.6 Modifications to be adopted with respect to the strength approach for aluminum, when HDPE is used - Plating (1/5/2023)

For the plate formulae (see Ch 3, Sec 2, [2.6], [2.10.2] and [2.11.1]), in case of impact pressure p_{si} or of plating of sub-division bulkheads:

$$\sigma_{am} = R_{eh} / 1.45 \text{ (in lieu of 95/K) MPa}$$

while in case of quasi-static pressure (external or internal):

$$\sigma_{am} = R_{eh} / 1.60 \text{ (in lieu of 85/K) MPa.}$$

In general, the HDPE structures are not suitable for the carriage of vehicles (concentrated loads), therefore the formulae for plating under wheeled loads in Ch 3, Sec 2, [2.6.7] cannot be applied.

The bending deflection, due to design pressure p , of a HDPE panel between stiffeners is not to be greater than about 2.5% of the stiffener spacing. The total deflection, in

mm, of a HDPE panel, fixed on its edges, is given by the formula:

$$f = \frac{\mu_2}{384} \cdot \frac{p \cdot s^4}{[EI]}$$

where:

[EI]: rigidity of the HDPE panel, for 1 mm width, in N*mm²/mm

μ_2 : 1, for $l \geq 2s$

$$1 - 2,1 \left(\frac{l}{2s} \right)^2 \text{ for } s < l < 2s$$

$$0,475, \text{ for } l \leq s$$

2.1.7 Modifications to be adopted with respect to the strength approach for aluminum, when HDPE is used - Ordinary stiffeners (1/5/2023)

For the ordinary stiffeners (see Ch 3, Sec 2, [2.7], [2.10.3] and [2.11.2]):

$\sigma_{am} = (R_{eh} * C_A) / 1.95$ MPa, for ordinary stiffeners contributing to the longitudinal strength (in lieu of $70 * C_A / K$):

or

$\sigma_{am} = R_{eh} / 1.95$ MPa, for ordinary stiffeners not contributing to the longitudinal strength (in lieu of 70 / K)

or

$\sigma_{am} = R_{eh} / 1.60$ MPa, for ordinary stiffeners of cross-deck bottom and internal sides of twin-hull craft, when subject to impact pressure (in lieu of 85 / K)

or

$\sigma_{am} = R_{eh} / 1.45$ MPa, for ordinary stiffeners of subdivision bulkheads (in lieu of 95 / K)

and

$\tau_{am} = \tau_{eh} / 1.2$ where τ_{eh} is the value minimum shear stress at yield for HDPE, see [2.1.1], in lieu of 45/K, in general

or

$\tau_{am} = \tau_{eh} / 1.05$ where τ_{eh} is the value minimum shear stress at yield for HDPE, see [2.1.1], in lieu of 55/K, for ordinary stiffeners of subdivision bulkheads.

2.1.8 Modifications to be adopted with respect to the strength approach for aluminum, when HDPE is used - Primary supporting (1/5/2023)

For the primary supporting members (see Ch 3, Sec 2, [2.8], [2.10.4] and [2.11.3])

$\sigma_{am} = (R_{eh} * C_A) / 1.95$ MPa, for primary supporting members contributing to the longitudinal strength (in lieu of $70 * C_A / K$):

or

$\sigma_{am} = R_{eh} / 1.95$ MPa, for primary supporting members not contributing to the longitudinal strength (in lieu of 70 / K)

or

$\sigma_{am} = R_{eh} / 1.60$ MPa, for primary supporting members of cross-deck bottom and internal sides of twin-hull craft, when subject to impact pressure (in lieu of 85 / K)

or

$\sigma_{am} = R_{eh} / 1.45$ MPa, for primary supporting members of subdivision bulkheads (in lieu of 95 / K)

and

$\tau_{am} = \tau_{eh} / 1.20$ MPa where τ_{eh} is the value minimum shear stress at yield for HDPE, see [2.1.1], in lieu of 45/K, in general

or

$\tau_{am} = \tau_{eh} / 1.05$ MPa where τ_{eh} is the value minimum shear stress at yield for HDPE, see [2.1.1], in lieu of 55/K, for primary supporting members of subdivision bulkheads.

The multipliers in Ch 3, Sec 2, [2.11] for the collision bulkheads are to be applied if the collision bulkhead is built with HDPE plates, ordinary stiffeners and primary supporting members.

2.1.9 Minimum ordinary stiffener section modulus (1/5/2023)

As a rule, the minimum section modulus of hull and deck secondary stiffeners is not to be less than 15 cm³.

2.1.10 Pillars (1/5/2023)

Pillars in HDPE are in general not allowed. Specific cases may be considered by the society based on strength and stiffness under compression.

3 Check for overall loads

3.1 Transverse section strength characteristics

3.1.1 (1/5/2023)

The calculation of the hull girder strength characteristics (section moduli at deck and at bottom) is to be carried out as defined in Ch 3, Sec 2, [2.4], considering all the longitudinal continuous structural elements of the hull.

The value of the hull girder bending longitudinal stress σ_{bl} is to be calculated according to the formulae in Ch 3, Sec 2, [2.4.1].

3.2 Yielding checks for overall loads

3.2.1 (1/5/2023)

Hull girder yielding strength is checked for the total (still water plus wave) overall loads in Ch 1, Sec 3, [3].

The value of the hull girder bending longitudinal stress σ_{bl} is not to exceed the value of 70% of R_{eh} (see [2.1.1]) in any point of the transverse section.

The value of the shear stress due to hull girder total shear force is not to exceed the value of 70% of τ_{eh} , the shear stress at yield for the HDPE (see [2.1.1]).

3.3 Buckling checks for overall loads

3.3.1 (1/5/2023)

Hull girder buckling strength is checked for the total (still water plus wave) overall loads in Ch 2, Sec 2, [3].

The value of the hull girder bending longitudinal stress and shear stress in the plating are not to exceed the critical longitudinal and shear buckling stresses as calculated in Ch

3, Sec 2, [2.5] with the following modifications to the formulae:

E: tensile young modulus of the HDPE (see [2.1.3]).

$R_{p0.2}$: to be taken equal to the value of R_{eh} tensile stress at yield of HDPE (see [2.1.3]).

Alternative methods to calculate the critical buckling tensile and shear stresses in the plating may be considered by the society.

The formulae in Ch 3, Sec 2, [2.5.4] a) and b) cannot be used for the axially loaded stiffeners built in HDPE.

The critical buckling tensile stress in the stiffeners will be specially considered by the society, based on E and R_{eh} , the tensile stress at yield of HDPE (see [2.1.3]).

3.4 Overall stiffness check

3.4.1 (1/5/2023)

The hull girder overall stiffness is checked for the total (still water plus wave) overall loads in Ch 2, Sec 2, [3].

The overall stiffness of the hull girder is to be checked to avoid excessive values of hull girder deflection that would impair the operability of the ship structure and plants. To this purpose, the maximum vertical deflection under the total hull girder loads is not to exceed, in general, the value of L/150 at any frame along the hull.

SECTION 4

HULL OUTFITTING

1 Application

1.1

1.1.1 (1/5/2023)

The requirements in Ch 1, Sec 2 apply.

SECTION 5

RUDDERS, EQUIPMENT AND TESTING

1 Rudders

1.1 Application

1.1.1 (1/5/2023)

The requirements in Pt B, Ch 10, Sec 1 of the Rules apply.

2 Equipment

2.1 Application

2.1.1 (1/5/2023)

The requirements in Pt B, Ch 10, Sec 4 of the Rules apply.

3 Testing

3.1 Application

3.1.1 (1/5/2023)

The requirements in Pt B, Ch 12, Sec 3 of the Rules apply.

RULES FOR THE CLASSIFICATION OF WORKBOATS

Part C Machinery, Systems and Fire Protection

Chapters 1 2

**Chapter 1 MACHINERY, ELECTRICAL INSTALLATIONS
AND AUTOMATION**

Chapter 2 FIRE PROTECTION

CHAPTER 1

MACHINERY, ELECTRICAL INSTALLATIONS AND AUTOMATION

Section 1 Machinery

1	Application, General Requirements and Documentation to be submitted 149	
	1.1	
2	Bilge systems	149
	2.1	
3	Fuel system	150
	3.1 Arrangement	
	3.2 Fuel tanks	
	3.3 Fuel piping	
4	Seawater cooling systems	151
	4.1 General	
5	Fresh water systems and grey water systems	151
	5.1 General	
6	Shell penetrations	151
	6.1 General	
7	Testing	151
	7.1 General	
8	Steering system	151
	8.1 General	
	8.2 Hydraulic steering system	
	8.3 Cable steering system	
	8.4 Steering wheel	
	8.5 Waterjet installations	
9	Outboard Installations	151
	9.1 General	
	9.2 Arrangement: installation and steering	
10	Shafting	152
	10.1 General	
11	Machinery	152
	11.1 Certification of Engines	
	11.2 Propulsion and auxiliary engines	
	11.3 Engine room	
	11.4 Engine controls	
	11.5 Exhaust	
	11.6 Propellers	
	11.7 Pressure vessels	
	11.8 Gears	

Section 2 Electrical Installations

1	Application	154
	1.1	
2	Earthing	154
	2.1 Earthing connections	
	2.2 Earthing plate	
3	Protection against lightning for vessels with reinforced plastic or wooden hull	154
	3.1 General	
	3.2 Air terminals	
	3.3 Down conductors	
	3.4 Earth terminations	
4	Electrolytic corrosion	155
	4.1 General	

Section 3 Automation

1	Application	156
	1.1	

CHAPTER 2

FIRE PROTECTION

Section 1 General

1	General	159
1.1	Application	
1.2	Documentation to be submitted	
1.3	Safety Plan	
2	Structural fire protection, ventilation, means of escape and fire detection	159
2.1	Structural fire protection	
2.2	Ventilation	
2.3	Means of access and escape	
2.4	Fire Detection and alarm	
3	Fixed fire extinguishing systems	160
3.1	General	
3.2	Aerosol system	
3.3	CO2 system	
3.4	Gaseous agent system	
3.5	Foam system	
3.6	Water mist system	
4	Mobile Fire appliances	160
4.1		

Part C
Machinery , Systems and Fire Protection

Chapter 1

**MACHINERY, ELECTRICAL INSTALLATIONS
AND AUTOMATION**

- SECTION 1 MACHINERY**
- SECTION 2 ELECTRICAL INSTALLATIONS**
- SECTION 3 AUTOMATION**

SECTION 1 MACHINERY

1 Application, General Requirements and Documentation to be submitted

1.1

1.1.1

For the systems for which this Section does not give requirements the requirements of Part C, Chapter 1 of the Rules as far as it is practicable and reasonably generally apply.

Materials used in piping systems are to be suitable for the liquid conveyed and the external environment to which they are exposed; different materials are not to be combined such that there is a possibility for galvanic corrosion.

All components in the installation are to have sufficient strength and be so mounted that the system including its foundations will withstand the accelerations and vibrations to which it may be exposed as well as the design pressure.

They are to be protected against mechanical damage. Expansion joints or equivalent arrangement are to be provided to allow expansion/contraction of pipes.

Where a failure of the connection will lead to flooding flexible hoses used in fuel system, seawater cooling system, bilge system and other systems are to be fitted with two stainless steel hose clips or pressed on end couplings.

Corrosion and temperature variation have to be taken into consideration.

Pipes or hoses are not to be installed over switchboard or electrical distribution panels except when they are metallic without junctions.

1.1.2 Documentation to be submitted

The documentation to be submitted to the Society, for approval, is listed in Tab 1.

Table 1 : Documentation to be submitted for approval, as applicable

No.	Item
1	Diagram of the bilge and ballast system (in and outside machinery spaces)
2	Diagram of the air, sounding and overflow systems
3	Diagram of cooling systems (sea water and fresh water)
4	Diagram of fuel oil system
5	Diagram of the lubricating oil system
6	Propeller
7	Gearing
8	Shaft line arrangement
9	Steering gear

2 Bilge systems

2.1

2.1.1

The bilge system is to be permanently installed.

The bilge system is to be able to drain all compartments except tanks.

The bilge system is to be made of steel, or suitable plastic material.

Metallic materials are to be used in the engine room. If flexible hoses are used they have to be of a type recognized by Tasneef and special attention is to be given to collapse due to suction.

2.1.2

Each watertight compartment is to be drained by a dedicated bilge branch and the branch is to be fitted with a non-return valve between the bilge main and the individual branch. The valve is to be operable from above the working platform. Special considerations may be done for small compartments.

2.1.3

One bilge pump driven directly by the engine or by electric motor is to be installed.

The internal diameter d , in mm, of the bilge main and the bilge suction branches leading from the various compartments is to be not less than that calculated according to the following formula:

$$d = 0,85 L + 25$$

Where:

L = load line length

However, the actual internal diameter defined above may be rounded off to the nearest standard size acceptable to Tasneef (in any case it is to be not more than 5 mm less than that obtained from the formula).

The capacity of the bilge pump is to be not less than that given by the following formula:

$$Q = 0,00565d^2$$

Where:

Q = capacity of the bilge pump in m³/h

d = rule inner diameter of the bilge main, in mm, calculated with the above formula.

The bilge pump is to be possible to operate from the steering position. In vessels larger than 6 m minimum two pumps are to be fitted, each with at least 60% of the capacity given above.

2.1.4

As an alternative separate bilge pumps may be installed for one or more compartments. Pumps are to be possible to operate from the steering position. The capacity of the pump is to be consistent with the length of the compartment to be drained.

2.1.5

For non-open vessel all the spaces are to be fitted with bilge alarm.

3 Fuel system

3.1 Arrangement

3.1.1

Fuel strainers, filters and water separators are to be easily accessible and it is to be possible to carry out maintenance works without stop the engines.

3.1.2

Fuel tanks are not to be located immediately above the engine room.

3.1.3

Fuel tanks may be independent or part of the boat structure. Independent fuel tanks are to be mounted such that air can circulate around the tank and that they can be readily inspected or movable for inspection.

3.2 Fuel tanks

3.2.1

Fuel tanks are to be fabricated from steel, aluminium, polyethylene or GRP. If made of steel aluminium or grp they have to be in accordance with Pt B and in accordance with what below:

- a) light alloy or equivalent material, provided that they are placed outside the propulsion engine room or, in case they are located inside this room, they are to be provided with an insulation equivalent to that of a class A60 division; similar insulation are to have the walls and / or bridges of deposits in common with the propulsion engine room.

- b) glass fiber reinforced plastic (GRP) provided that:

- the total volume of independent deposits / tanks installed in a single room does not exceed 6 m³ for deposits, and 4.5 m³ for independent tanks; and
- the fiberglass-reinforced plastic structure of the deposits and independent tanks has characteristics, including that of fire resistance, deemed suitable by Tasneef

- c) polyethylene provided that:

- the independent tanks are intended to contain only diesel fuel (polyethylene tanks containing petrol are not acceptable)
- the tanks are CE marked in accordance with ISO 21487 and have passed - even if containing only diesel fuel - the fire test required by the above ISO for tanks containing petrol
- the total volume of tanks installed in a single room is less than 1 m³
- if installed in category A machinery spaces, it is covered by an approved fixed fire detection and extinguishing system and the tank is integrated into the hull structures (only the upper surface of the tank may not be close to the hull structures)

It is not allowed to use the forward locker, nor other compartments forward of the collision bulkhead, as a deposit of liquid fuel.

Tanks in engine room are to be fabricated from steel or aluminium.

Each tank is to have separate filling pipe and air vent. The air vent is to be mounted in a way to prevent water from entering the tank. The filling pipe is to have an internal diameter of at least 38 mm. The vent pipe is to have an internal diameter of at least 16 mm. If the filling pipe has a screw coupling or similar device for the filling line, the internal cross sectional area of the vent pipe is not to be smaller than 125% of the internal cross sectional area of the filling pipe.

The amount of fuel in the tank arrangement is to be possible to verify at any given time, e.g by fitting a level gauge to each tank. External sight glass is to have a self-closing valves.

3.3 Fuel piping

3.3.1

Fuel lines are to be so arranged that a leakage can not occur on to sources of ignition (e.g. hot surfaces).

3.3.2

The engine is to be connected to the fuel line by a short flexible hose satisfying at least the requirements of ISO 7840 with at least two stainless steel hose clips suitably fixed at each connection. Flexible hoses under pressure have to be provided with clamped ends.

3.3.3

Fuel lines are to be equipped with a metallic shut-off valve mounted on the tank possible to be closed easily from above deck.

4 Seawater cooling systems

4.1 General

4.1.1

In sea water system, flexible hoses may be fitted if satisfying ISO 7840 provided that they are protected against mechanical damage and possibly above the design waterline. Flexible hoses end is to be in accordance with [3.3.2].

4.1.2

Seawater intakes are to have strainers or filters and it is to be possible to carry out maintenance works without stop the engines.

5 Fresh water systems and grey water systems

5.1 General

5.1.1

Fresh and Gray water tanks may be independent or part of the vessel structure and accessible for cleaning and filled/empty from above the deck.

5.1.2

Integral freshwater tanks are not to be located contiguous to fuel or grey water tanks.

5.1.3

Grey water is to be collected in dedicated tanks.

6 Shell penetrations

6.1 General

6.1.1

Overboard suction and discharges with lower end located lower than 200 mm above deepest waterline are to be arranged with a non-return closing valve. This valve is to be made of metallic ductile material and is to be easy accessible. For this valve an open/closed indication or other equivalent means for preventing water from passing inboard is to be provided. Only for structural scuppers coming from the deck a non-return valve is acceptable.

7 Testing

7.1 General

7.1.1

the requirements of Pt C, Ch 1 of the Rules as far as it is practicable and reasonably generally apply.

8 Steering system

8.1 General

8.1.1

The steering arrangement is to be suitable to manoeuvre the vessel at the maximum power and it is to be suitable protected from damages.

8.1.2

An emergency means of steering is to be provided in case of failure of the main steering system.

8.1.3

Rudder stops are to be provided.

8.2 Hydraulic steering system

8.2.1

The capacity of the steering system is to be verified and is to be tested during sea trials.

8.2.2

The complete installation is to be tested for leaks at a suitable pressure.

8.2.3

Hand operated hydraulic steering systems CE-marked according to RCD Directive may be accepted. The system is to be installed according to the manufacturers instructions.

8.3 Cable steering system

8.3.1

Cable steering systems CE-marked according to RCD Directive may be accepted. They are to be installed according to the manufacturers recommendations.

8.4 Steering wheel

8.4.1

Steering wheels are to be normally CE-marked according to RCD Directive. Not CE-marked steering wheels on very small vessel will be evaluated on a case by case basis.

8.5 Waterjet installations

8.5.1

The manufacturer of the water jet installation has to declare the forces acting on the vessel from the water jet.

9 Outboard Installations

9.1 General

9.1.1

Vessel with outboard engines has to comply with ISO 11547.

9.1.2

Vessels equipped with outboard engines with a power exceeding 15 kW are to be provided with permanent wheel steering and relevant stops. Tasneef may require permanent wheel steering also for other vessels if found necessary.

9.2 Arrangement: installation and steering

9.2.1

Outboard engines are to be secured to the stern using through bolts.

For outboard engines with power less or equal to 15 kW as an alternative the transom may be fitted with a well fastened plate as a protection for the fastening screws for the engine. The upper part of the plate is to have a ridge of at least 5

mm to prevent the engines fastening screws from slipping over the edge.

9.2.2

Outboard engines with power greater than 15 kW are to be provided with remote steering and controls.

9.2.3

Vessel fitted with outboard engines where the power exceeds 100 kW are to be fitted in an engine well drained to the sea.

9.2.4

The steering gear is to be designed for a force K not less than:

$$K = 10P \text{ (N)}$$

where P is the engine power in kW.

9.2.5

Consoles and all components at the steering position are to be built, stiffened and secured in such a way that they can absorb the forces to which they are exposed.

10 Shafting

10.1 General

10.1.1 Propeller, intermediate and thrust shafts

The minimum diameter of intermediate and propeller shafts is not to be less than the value given by the following formula:

$$d = k \cdot \left[\frac{P}{n \cdot (1 - Q^4)} \cdot \frac{560}{R_m + 160} \right]^{1/3}$$

where:

d : rule diameter of the intermediate or propeller shaft, in mm

k : 90, for all types of shafts

P : maximum service power, in kW

n : shaft rotational speed, in r.p.m., corresponding to P power

Q : 0, in the case of solid shafts

ratio of the hole diameter to the outer shaft diameter in the concerned section, in the case of a hollow shaft; where $Q \leq 0,3$, $Q = 0$ is to be taken.

Hollow shafts whose longitudinal axis does not coincide with the longitudinal hole axis will be specially considered by Tasneef in the individual cases.

R_m : value of the minimum tensile strength of the shaft material, in N/mm².

Intermediate and propeller shafts having an actual minimum diameter less than above rule diameter may be accepted, provided they are based on documented satisfactory service experience and/or on technical documents submitted by the Manufacturer to Tasneef and deemed suitable by the latter.

11 Machinery

11.1 Certification of Engines

11.1.1

Engines are to be of recognised type suitable for maritime use. Engines with a power exceeding 2500 kW are to be Type Approved by Tasneef or another recognised organisation.

11.2 Propulsion and auxiliary engines

11.2.1

When L x B is more than 40 inboard engines have to be fitted for main propulsion.

Only inboard engines using fuel with flashpoint of more than 55°C are allowed.

11.3 Engine room

11.3.1

The engine room is not to be used for other purposes. The engines control position is to be readily accessible and safe from hot surfaces and dangerous rotating parts and equipped with artificial lighting.

11.3.2

Glazed openings in engine room are to have the same fire rating as surrounding structure.

11.3.3

Forced ventilation is to be provide as per Manufacturer of the engine instructions.

11.4 Engine controls

11.4.1

The following indicators or alarms of the engines are to be visible/audible in the steering gear position with adjustable lighting:

- speed of revolutions (only for main propulsion engines)
- lubrication oil pressure
- cooling water temperature
- alarm for loss of exhaust cooling

11.5 Exhaust

11.5.1

Exhaust system to be in accordance with manufacturer's recommendations. Normally separate and easy accessible exhaust are required.

11.5.2

Exhaust line with a surface temperature exceeding 80°C is to be suitably insulated.

11.5.3

Seawater cooled exhaust systems are to be equipped with alarm at the steering position for loss of seawater cooling or for high temperature in the exhaust pipe

11.5.4

Exhaust outlets are to be at least 100 mm above loaded water line or the exhaust line is to consist of a metallic pipe brought at least 100 mm above loaded water line.

11.5.5

Flexible rubber and plastic hoses for wet-exhaust system is to be in accordance with ISO 13363.

11.6 Propellers

11.6.1

Propellers have to be made of metallic material, have to be made by a recognized Manufacturer and installed in accordance with the Manufacturer's instruction.

11.7 Pressure vessels

11.7.1

Pressure vessel have to be provided with a certification deemed suitable by Tasneef

11.8 Gears

11.8.1

Gears have to be made by a recognized Manufacturer and installed in accordance with the Manufacturer's instruction

SECTION 2

ELECTRICAL INSTALLATIONS

1 Application

1.1

1.1.1

The requirements of Part C, Chapter 2 of the Rules generally apply.

Moreover, for vessels with reinforced plastic the requirements of this Section apply.

2 Earthing

2.1 Earthing connections

2.1.1 Where earthing connection is required, a conductor is to be provided with the function of collector connected to a specific earthing plate.

2.2 Earthing plate

2.2.1 The earthing plate is to be a plate, free from paint, having a thickness of at least 2 mm and a surface area not less than 0,25 m², fixed to the hull below the lowest water-line so as to remain fully submerged in any listing or heeling condition.

2.2.2 The earthing plate is to be made of copper or other conductive material, compatible with sea water and having a surface area such as to give a resistance equivalent to that of a copper earthing connection. The formation of electrochemical couples with other immersed metallic materials, which could cause electrolytic corrosion, is to be avoided.

3 Protection against lightning for vessels with reinforced plastic or wooden hull

3.1 General

3.1.1 A protection system against lightning is to be provided on vessels with reinforced plastic or wooden hull.

3.1.2 The protection system against lightning is to include air terminals, down conductors and earth terminations.

3.1.3 Metallic masts and metallic structural elements may constitute part or the whole of the protection system.

3.1.4 Metallic equipment may act as natural down conductors and is to be connected to the protection system.

3.1.5 The electrical resistance between the air terminal and the earth termination is not to exceed 0,02 Ω.

3.1.6 The down conductor joints are to be accessible and located or protected so as to minimize the risk of accidental damage. They are to be made by means of rivets or compression clamps. Compression clamps may be of copper or copper alloys and should preferably be of the notched contact type and securely tightened. No welded connection is allowed.

3.1.7 The protection system against lightning is to be installed so as to minimize the risk of induction voltages in the electric cables due to the passage of lightning currents.

3.1.8 When the vessel is in drydock or on a slipway, suitable means are to be provided to connect the protection system against lightning to the earthing system of drydock or slipway. The conductors for this connection are to have a length as short as practicable and a cross section not smaller than that electrically equivalent to 100 mm² of copper.

3.2 Air terminals

3.2.1 Each non-metallic mast is to be provided with an air terminal (see Note 1)

Note 1: The positioning of air terminals on the vessel masts may be effected taking into account the protection angle method specified in the CEI 81-1 standard.

3.2.2 The air terminal is to consist of a conductive bar, made of copper or copper alloy, having a diameter not less than 12 mm, and a height of at least 300 mm above the top of the mast. Other materials may be used, such as, for example, stainless steel or steel bars protected against corrosion, provided that they meet the requirements in [3.1.7]. The material is to be resistant to sea water.

3.3 Down conductors

3.3.1 Down conductors are to consist of a small plate or cable made of copper or copper alloy. Other materials may be used, such as, for example, stainless steel or steel bars protected against corrosion, provided that they meet the requirements in [3.1.7]. The material is to be resistant to sea water.

3.3.2 Copper down conductors are to have a cross section not less than 70 mm², be securely fixed to the structure and run as far as practicable on a straight line between the air terminal and the earth termination. Direction changes, where necessary, are to have a minimum radius of at least 10 times the equivalent conductor diameter.

3.4 Earth terminations

3.4.1 Earth terminations are to be constructed and installed as specified in [2.2].

3.4.2 Earth terminations are to be additional to and separate from the earthing plate, mentioned in [2.2].

4 Electrolytic corrosion

4.1 General

4.1.1 Metallic parts in contact with sea water, such as valves, pipes, engine casings, etc., not otherwise protected

against electrolytic corrosion, are to be electrically connected to a copper conductor having the function of collector, connected in turn to sacrificial anodes.

SECTION 3

AUTOMATION

1 Application

1.1

1.1.1 The requirements of Part C, Chapter 3 of the Rules generally apply.

Part C
Machinery, Systems and Fire Protection

Chapter 2
FIRE PROTECTION

SECTION 1 GENERAL

SECTION 1

GENERAL

1 General

1.1 Application

1.1.1

The requirements of the Flag Administration may be applied instead of those of this chapter.

1.2 Documentation to be submitted

1.2.1

The following drawings are to be submitted to Tasneef:

- Structural fire protection
- Ventilation
- Means of escape
- Fire detection
- Fixed fire extinguishing system
- Mobile Fire application
- Safety plan (if required)

1.3 Safety Plan

1.3.1

If required the safety plan is to include:

- life saving equipment
- fire alarm and fire fighting
- emergency exits
- emergency systems (alarms, fans, valves etc.).

In addition for information only:

- emergency instruction
- first aids

2 Structural fire protection, ventilation, means of escape and fire detection

2.1 Structural fire protection

2.1.1

Acoustic insulation material used in engine spaces is to as a minimum have a non-fuel-absorbent surface towards the engine and an oxygen index of at least 21 in accordance with ISO 4589-3 at an ambient temperature of 60°C.

Engine spaces in vessel made of GRP of more than 15 m are to be made with laminated construction with fire retarding resin and/or intumescent resin.

2.1.2

Engine room in vessel made of glass reinforced plastic of more than 15 m is to be enclosed with fire protection of minimum 15 minutes rating. Arrangement and materials for structural fire protection are to be recognized by Tasneef. The

fire protection is to cover the entire boundary of the engine room starting from 300mm below the lowest waterline.

2.1.3

Engine room in vessel made of glass reinforced plastic of not more than 15 m is to be made with laminated construction with fire retarding resin and/or intumescent resin.

2.2 Ventilation

2.2.1

Openings for ventilation of the engine space are to be equipped with closing appliances readily operable from the outside of the engine room.

2.2.2

Tank spaces separated from engine room is to be fitted with suitable ventilation.

2.3 Means of access and escape

2.3.1

All accommodation, service spaces and machinery spaces that are accessible have to be provide with at least 2 means of escape located as far as possible from each other, and be suitable to be used in an emergency.

Width of corridors in accommodation and machinery area is to be at least 700 mm in general, 600 mm for spaces not normally used.

Accommodation for maximum 4 persons may be accepted with only one escape if this cannot be blocked in case of fire or other emergency situation and if it leads directly to open deck.

Normally escape hatches have to be:

- minimum light opening 450 × 450 mm, or equivalent
- provided with fixed step, ladder and handholds where necessary
- clearly marked and with appropriate instructions
- readily opened from both sides without tools
- direct access to open deck or to a safe escape route.

Emergency light has to be provided for accommodation and relevant escape ways.

Reference may be done to ISO 9094.

2.4 Fire Detection and alarm

2.4.1

The engine spaces are to be equipped with a fire detection system with both audible and visible alarm at the helm position. The detection system may be integrated in the fixed fire extinguishing system.

3 Fixed fire extinguishing systems

3.1 General

3.1.1

The Engine room is to be protected by a fixed fire-fighting extinguishing system.

The system is to be a manual system or a manual/automatic combined system if applicable. A manual release system is to be activated from the helm position. The system activation controls are to be protected from environment and unintended operation and provided with operation instructions.

Automatic release of the system, acceptable only in unmanned rooms, is to be indicated by both audible and visual alarms at the helm position. The mechanical ventilation and the engines have to be automatically shut down in case of activation of the fixed fire extinguishing system.

3.1.2

The extinguishing medium is to be suitable for the intended use and its amount and time of acting suitable for the intended use.

3.1.3

The fixed fire extinguishing system is to be of one of the following types:

- aerosol system
- CO₂ system
- gaseous agent
- high expansion foam system
- water mist systems.

3.1.4

Cylinders for the extinguishing medium are to be protected from environment and unintended operation, mechanical damage and temperatures exceeding 50°C. Cylinders are not to be located in accommodation spaces.

3.1.5

Nozzles are to be located to grant uniform distribution of the extinguishing agent.

3.2 Aerosol system

3.2.1

Aerosol system is to be type approved according to IMO MSC/Circ. 1007.

3.2.2

The system may be either a manual or a manual/automatic combined system.

3.3 CO₂ system

3.3.1

The system is to be manually operated only. Discharge is to be indicated by both audible and visible alarm.

3.3.2

The amount of extinguishing medium is to be minimum 0.6 kg/m³ net volume, but in any case not less than 2 kg in total.

3.3.3

CO₂ cylinders are not to be located in the engine room.

3.3.4

CO₂ cylinders or fittings on distribution lines are not to be located in a way that any extinguishing medium can enter into the accommodation area in the event of leakage in the system.

3.3.5

CO₂ systems are to have a separate fire detection system.

3.4 Gaseous agent system

3.4.1

Gaseous agent system is to be type approved according to IMO MSC/Circ. 848, as amended by Circ. 1267.

3.4.2

The system may either be a manual or a manual/automatic combined system.

3.5 Foam system

3.5.1

The system may either be a manual or a manual/automatic combined system.

3.6 Water mist system

3.6.1

Water mist system is to be type approved according to IMO Circ. 1165

3.6.2

The system may either be a manual or a manual/automatic combined system.

3.6.3

A water mist system is to be designed for a protection time of at least 20 minutes.

3.6.4

Water based systems requiring fresh water are to be connected to dedicated water tanks with capacity for minimum 5 minutes operation for the largest space, and automatic switch-over to sea-water supply. Alternatively manual switchover may be used if the capacity of the fresh water tank is increased to 15 minutes.

4 Mobile Fire appliances

4.1

4.1.1

Any portable fire extinguisher is to be type approved according to the Marine Equipment Directive or other national recognized standard.

4.1.2

Any individual portable extinguisher is to have a maximum capacity for type EI according to Tab.1.

A suitable sized fire extinguisher is to be fitted in the following locations:

- close to the main helm position (at least one EII)
- in the accommodation area (at least one EI each 20m)
- close to any permanent installed cooker/stove or open flame device or cooking appliance (at least one DII).

4.1.3

Portable CO₂ extinguishers are not to be fitted in accommodation spaces.

4.1.4

If the portable fire extinguisher is located where it is exposed to splashed or sprayed water, the nozzle and triggering device is to be shielded.

4.1.5

The extinguisher may be stowed in a locker or other enclosed space. The locker or opening part of the space is to be labelled.

4.1.6

If an open-flame cooker is fitted, a fire blanket, in accordance with EN 1869, is to be within reach and readily accessible for immediate use.

Table 1 :

Type	Foam (litres)	Carbon dioxide (kg)	Dry chemical powder (kg)
D-II	9	-	-
E-II	9	5	4
F-II	-	5	4
E-I	6	2	1

