

# Rules for the Classification of Floating Offshore Units at Fixed Locations and Mobile Offshore Drilling Units

*Effective from 1 January 2026*

## Part D

Materials and Welding

**GENERAL TERMS AND CONDITIONS**  
**OF EMIRATES CLASSIFICATION SOCIETY – L.L.C – O.P.C (TASNEEF)**  
**EFFECTIVE AS OF 1 APRIL 2025**

**DEFINITIONS**

<b>Administration</b>	means the government of the state whose flag the Ship is entitled to fly or under whose authority the Ship is authorised to operate in the specific case.
<b>Client</b>	means the interested party and any other party who requires the Services.
<b>Certificate of Classification</b>	means a certificate of classification, issued by a Society and the certificate confirms that the vessel's structure, machinery, and equipment meet the society's specific technical rules and regulations.
<b>Interested Party</b>	means the party, other than the society, having an interest in or responsibility for the Ship, product, plant or system subject to classification or certification (such as the owner of the Ship and his representatives, the Ship builder, the engine builder or the supplier of parts to be tested) who requests the Services or on whose behalf the Services are requested.
<b>Owner</b>	means the registered owner, the Ship owner, the manager or any other party with the responsibility, legally or contractually, to keep the Ship seaworthy or in service, having particular regard to the provisions relating to the maintenance of class laid down in part a, chapter 2 of the rules for the classification of Ships or in the corresponding rules indicated in the specific rules.
<b>Register of Ships</b>	means a register book, also known as a Register of Ships, is a comprehensive record of vessels that are classified by a society.
<b>Rules</b>	means the documents below issued by the Society: <ul style="list-style-type: none"> <li>a. Rules for the classification of Ships or other special units.</li> <li>b. Complementary rules containing the requirements for certification of products, plants, systems and other or containing the requirements for the assignment of additional class notations.</li> <li>c. Rules for the application of statutory rules, containing the rules to perform the duties delegated by administrations.</li> <li>d. Guides to carry out particular activities connected with Services.</li> <li>e. Any other technical document, as for example rule variations or interpretations.</li> </ul>

**GENERAL TERMS AND CONDITIONS**  
**OF EMIRATES CLASSIFICATION SOCIETY – L.L.C – O.P.C (TASNEEF)**  
**EFFECTIVE AS OF 1 APRIL 2025**

**DEFINITIONS**

<b>Administration</b>	means the government of the state whose flag the Ship is entitled to fly or under whose authority the Ship is authorised to operate in the specific case.
<b>Client</b>	means the interested party and any other party who requires the Services.
<b>Certificate of Classification</b>	means a certificate of classification, issued by a Society and the certificate confirms that the vessel's structure, machinery, and equipment meet the society's specific technical rules and regulations.
<b>Interested Party</b>	means the party, other than the society, having an interest in or responsibility for the Ship, product, plant or system subject to classification or certification (such as the owner of the Ship and his representatives, the Ship builder, the engine builder or the supplier of parts to be tested) who requests the Services or on whose behalf the Services are requested.
<b>Owner</b>	means the registered owner, the Ship owner, the manager or any other party with the responsibility, legally or contractually, to keep the Ship seaworthy or in service, having particular regard to the provisions relating to the maintenance of class laid down in part a, chapter 2 of the rules for the classification of Ships or in the corresponding rules indicated in the specific rules.
<b>Register of Ships</b>	means a register book, also known as a Register of Ships, is a comprehensive record of vessels that are classified by a society.
<b>Rules</b>	means the documents below issued by the Society: <ul style="list-style-type: none"> <li>a. Rules for the classification of Ships or other special units.</li> <li>b. Complementary rules containing the requirements for certification of products, plants, systems and other or containing the requirements for the assignment of additional class notations.</li> <li>c. Rules for the application of statutory rules, containing the rules to perform the duties delegated by administrations.</li> <li>d. Guides to carry out particular activities connected with Services.</li> <li>e. Any other technical document, as for example rule variations or interpretations.</li> </ul>

<b>Services</b>	means the activities described in Article 1 below, rendered by the Society upon request made by or on behalf of the Interested Party.
<b>Ship</b>	means ships, boats, craft and other special units, as for example offshore structures, floating units and underwater craft.
<b>Society</b>	means Emirates Classification Society LLC OPC and/or its affiliated entities providing the Services.
<b>Surveyor</b>	means technical staff acting on behalf of the society in performing the Services.
<b>UAE</b>	means United Arab Emirates.

#### ARTICLE 1

- 1.1 The purpose of the Society is, among others, the classification and certification of Ships and the certification of their parts and components.
- 1.2 The Society (a) sets forth and develops Rules; (b) publishes the Register of Ships; and (c) issues certificates, statements and reports based on its survey activities.
- 1.3 The Society also takes part in the implementation of national and international rules and standards as delegated by various Governments.
- 1.4 The Society carries out technical assistance activities on request and provides special services outside the scope of classification, which is regulated by these general conditions unless expressly excluded in the particular contract.

#### ARTICLE 2

- 2.1 The Rules developed by the Society reflect the level of its technical knowledge at the time they are published. Therefore, the Society, though committed, also through its research and development services, to continuous updating, does not guarantee they meet state-of-the-art science and technology at the time of publication or that they meet the Society's or others' subsequent technical developments.
- 2.2 The Interested Party is required to know the Rules on the basis of which the Services are provided. With particular reference to Classification Services, special attention is to be given to the Rules concerning class suspension, withdrawal and reinstatement. In case of doubt or inaccuracy, the Interested Party is to promptly contact the Society for clarification. The Rules for Classification of Ships are published on the Society's website: [www.tasneefmaritime.ae](http://www.tasneefmaritime.ae)
- 2.3 The Society exercises due care and skill:
  - (a) in the selection of its Surveyors; and
  - (b) in the performance of its Services, taking into account the level of its technical knowledge at the time the

Services are performed.

- 2.4 Surveys conducted by the Society include, but are not limited to, visual inspection and non-destructive testing. Unless otherwise required, surveys are conducted through sampling techniques and do not consist of comprehensive verification or monitoring of each component of the Ship or of the items subject to certification. The surveys and checks made by the Society, either on board Ships or with remote techniques, do not necessarily require the constant and continuous presence of the Surveyor. The Society may also commission laboratory testing, underwater inspection and other checks to qualified service suppliers, who will carry out these duties under their responsibility. Survey practices and procedures are selected by the Society based on its experience and knowledge and according to generally accepted technical standards in the sector.

### ARTICLE 3

- 3.1 The class assigned to a Ship, like the reports, statements, certificates or any other document or information issued by the Society, reflect the discretionary opinion of the Society concerning compliance, at the time the Service is provided, of the Ship or product subject to certification, with the applicable Rules (given the intended use and within the relevant time frame).
- 3.2 The Society is under no obligation to make statements or provide information about elements or facts which are not part of the specific scope of the Service requested by the Interested Party or on its behalf.
- 3.3 No report, statement, notation on a plan, review, Certificate of Classification, document or information issued or given as part of the Services provided by the Society shall have any legal effect or implication other than a representation that, on the basis of the checks made by the Society, the Ship, structure, materials, equipment, machinery or any other item covered by such document or information meet the Rules. Any such document is issued solely for the use of the Society, its committees and clients or other duly authorised bodies and for no other purpose. Therefore, the Society cannot be held liable for any act made or document issued by other parties on the basis of the statements or information given by the Society. The validity, application, meaning and interpretation of a Certificate of Classification, or any other document or information issued by the Society in connection with its Services, are governed by the Rules of the Society, whom is the sole subject entitled to make such authentic interpretation. Any disagreement on technical matters between the Interested Party and the Surveyor in the carrying out of his functions shall be raised in writing as soon as possible with the Society, which will settle any divergence of opinion or dispute.
- 3.4 The classification of a Ship, or the issuance of a certificate or other document connected with classification or certification and in general with the performance of Services by the Society shall have the validity conferred upon it by the Rules of the Society at the time of the assignment of class or issuance of the certificate; in no case shall it amount to a statement or warranty of seaworthiness, structural integrity, quality or fitness for a particular purpose or service of any Ship, structure, material, equipment or machinery inspected or tested by the Society.
- 3.5 Any document issued by the Society in relation to its activities reflects the condition of the Ship or the subject of certification or other activity at the time of the check.
- 3.6 The Rules, surveys and activities performed by the Society, reports, certificates and other documents issued by

the Society are in no way intended to replace the duties and responsibilities of other parties including, without limitation, Governments, designers, ship builders, manufacturers, repairers, suppliers, contractors or sub-contractors, Owners, operators, charterers, underwriters, sellers or intended buyers of a Ship or other product or system surveyed.

- 3.7 These documents and activities do not relieve such parties from any fulfilment, warranty, responsibility, duty or obligation (also of a contractual nature) expressed or implied or in any case incumbent on them, nor do they confer on such parties any right, claim or cause of action against the Society. With particular regard to the duties of the Owner, the Services undertaken by the Society do not relieve the Owner of his duty to ensure proper maintenance of the Ship and ensure seaworthiness at all times. Likewise, the Rules, surveys performed, reports, certificates and other documents issued by the Society are intended neither to guarantee the buyers of the Ship, its components or any other surveyed or certified item, nor to relieve the seller of the duties arising out of the law or the contract, regarding the quality, commercial value or characteristics of the item which is the subject of transaction.
- 3.8 In no case, therefore, shall the Society assume the obligations incumbent upon the above-mentioned parties, even when it is consulted in connection with matters not covered by its Rules or other documents.
- 3.9 In consideration of the above, and within the limits of liability under Article 5 below, the Interested Party undertakes to relieve and hold harmless the Society from any third party claim, as well as from any liability in relation to the latter concerning the Services rendered, where these are attributable to the Interested Party.
- 3.10 Insofar as they are not expressly provided for in these General Conditions, the duties and responsibilities of the Owner and Interested Parties with respect to the Services rendered by the Society are described in the Rules applicable to the specific Service rendered.

#### ARTICLE 4

- 4.1 Any request for the Society's Services shall be submitted in writing and signed by or on behalf of the Interested Party. Such a request will be considered irrevocable as soon as received by the Society and shall entail acceptance by the applicant of all relevant requirements of the Rules, including these General Conditions. Upon acceptance of the written request by the Society, a contract between the Society and the Interested Party is entered into, which is regulated by the present General Conditions.
- 4.2 In consideration of the Services rendered by the Society, the Interested Party and the person requesting the service shall be jointly liable for the payment of the relevant fees and costs, even if the service is not concluded for any cause not pertaining to the Society. In the latter case, the Society shall not be held liable for non-fulfilment or partial fulfilment of the Services requested. In the event of non-payment of the invoice within the contractually agreed terms, the Society reserves the right to request, in addition to the full payment of the principal amount due and without the need for further formal notice, also:
- (a) Late payment interest at a rate of 5% per annum, calculated from the due date of the invoice until full payment is received, in accordance with the applicable laws in the United Arab Emirates or the country from where the invoice is issued. Any applicable VAT, taxes, or statutory levies shall be borne by the Client as per the laws

of the respective jurisdiction;

- (b) full reimbursement of any costs incurred for debt recovery, including, but not limited to, legal fees, administrative expenses, and the costs of any extrajudicial actions; and
- (c) any additional amount due as compensation for damages suffered as a result of the delay or non-compliance, where documented.

- 4.3 The contract for the classification of a Ship or for other Services may be terminated and any certificates revoked at the request of one of the parties, subject to at least 30 days' notice to be given in writing. Failure to pay, even in part, the fees due for Services carried out by the Society will entitle the Society to immediately terminate the contract and suspend the Services.
- 4.4 The Society may withhold, suspend or withdraw any certificate, report or service in the event of non-payment of fees due to any member of the Society by the Client in relation to the entire business relationship between any member of the Society and the Client or by any other companies belonging to the same group as the Client. This also applies when the obligation to pay rests with a builder or with the Ship's previous Owner.
- 4.5 For every case of termination or suspension of the contract, the fees for the activities performed until the time of the termination or of the suspension shall be owed to the Society as well as the expenses incurred in view of activities already programmed; this is without prejudice to the right to compensation due to the Society as a consequence of the termination or of the suspension.
- 4.6 With particular reference to Ship classification and certification, unless decided otherwise by the Society, termination of the contract implies that the assignment of class to a Ship is withheld or, if already assigned, that it is suspended or withdrawn; any statutory certificates issued by the Society will be withdrawn in those cases where provided for by agreements between the Society and the flag State.

#### **ARTICLE 5**

- 5.1 In providing the Services, as well as other correlated information or advice, the Society, its Surveyors, servants or agents operate with due diligence for the proper execution of the activity. However, considering the nature of the activities performed (see Article 2), it is not possible to guarantee absolute accuracy, correctness and completeness of any information or advice supplied. Express and implied warranties are specifically disclaimed.
- 5.2 Therefore, subject to what provided for in Article 5.3 below, and also in the case of activities carried out by delegation of Governments, neither the Society nor any of its Surveyors will be liable for any loss, damage or expense of whatever nature sustained by any person, in tort or in contract, derived from carrying out the Services.
- 5.3 Notwithstanding the provisions in Article 5.1 above, should any user of the Society's Services prove that he has suffered a loss or damage due to any negligent act or omission of the Society, its Surveyors, servants or agents, then the Society will pay compensation to such person for his proved loss, up to, but not exceeding, five times the amount of the fees charged for the specific Services, information or opinions from which the loss or damage derives or, if no fee has been charged, a maximum of AED5,000 (Arab Emirates Dirhams Five Thousand only).
- 5.4 Where the fees charged are related to a number of Services, the amount of the fees will be apportioned for the purpose of the calculation of the maximum compensation, by reference to the estimated time involved in the

performance of the Service from which the damage or loss derives. Any liability for indirect or consequential loss, damage or expense is specifically excluded. In any case, irrespective of the amount of the fees charged, the maximum damages payable by the Society will not be more than AED 300,000 (Three Hundred Thousand Dirhams). Payment of compensation under this Article will not entail any admission of responsibility and/or liability by the Society and will be made without prejudice to the disclaimer clause contained in Article 5.

- 5.5 Any claim for loss or damage of whatever nature by virtue of the provisions set forth herein shall be made to the Society in writing, within the shorter of the following periods: THREE MONTHS from the date on which the Services were performed or THREE MONTHS from the date on which the damage was discovered. Failure to comply with the above deadline will constitute an absolute bar to the pursuit of such a claim against the Society.

#### ARTICLE 6

- 6.1 Any dispute, controversy, or claim arising out of or relating to these Rules, the Services of the Society, or the interpretation, breach, or termination thereof, shall first be referred to the parties' senior management for amicable resolution within thirty (30) days of written notice by either party.
- 6.2 If the dispute is not resolved amicably under Article 6.1, it shall be exclusively governed by and construed in accordance with the laws of the Emirate of Abu Dhabi and the applicable federal laws of the United Arab Emirates. The courts of Abu Dhabi shall have exclusive jurisdiction to settle any such dispute.

#### ARTICLE 7

- 7.1 All plans, specifications, documents and information provided by, issued by, or made known to the Society, in connection with the performance of its Services, will be treated as confidential and will not be made available to any other party other than the Owner without authorisation of the Interested Party, except as provided for or required by any applicable legislation from a competent authority. Information about the status and validity of class and statutory certificates, including transfers, changes, suspensions, withdrawals of class, conditions of class, operating conditions or restrictions issued against classed ships and other related information, as may be required, may be published on the website or released by other means, without the prior consent of the Interested Party.
- 7.2 Information about the status and validity of other certificates and statements may also be published on the website or released by other means, without the prior consent of the Interested Party.
- 7.3 Notwithstanding the general duty of confidentiality owed by the Society to its clients in Article 7.1 above, the Society's clients hereby accept that the Society will participate in the IACS Early Warning System which requires each Classification Society to provide other involved Classification Societies with relevant technical information on serious hull structural and engineering systems failures, as defined in the IACS Early Warning System (but not including any drawings relating to the Ship which may be the specific property of another party), to enable such useful information to be shared and used to facilitate the proper working of the IACS Early Warning System. The Society will provide its clients with written details of such information sent to the involved Classification Societies.
- 7.4 In the event of transfer of class, addition of a second class or withdrawal from a double/dual class, the Interested Party undertakes to provide or to permit the Society to provide the other Classification Society with all building plans and drawings, certificates, documents and information relevant to the classed unit, including its history file,

as the other Classification Society may require for the purpose of classification in compliance with the applicable legislation and relative IACS Procedure. It is the Owner's duty to ensure that, whenever required, the consent of the builder is obtained with regard to the provision of plans and drawings to the new Society, either by way of appropriate stipulation in the building contract or by other agreement.

- 7.5 In the event that the ownership of the Ship, product or system subject to certification is transferred to a new subject, the latter shall have the right to access all pertinent drawings, specifications, documents or information issued by the Society or which have come to the knowledge of the Society while carrying out its Services, even if related to a period prior to transfer of ownership.

#### ARTICLE 8

- 8.1 The Society shall not be obliged to perform any obligation towards the Client (including, without limitation, obligation to (a) perform, deliver, accept, sell, purchase, pay or receive money to, from or through a person or entity, or (b) engage in any other act) if this would be in violation of, inconsistent with or expose the Society to punitive measures under any United Nations resolutions and/or under any laws, regulations, decrees, ordinances, orders, demands, requests, rules or requirements of EU, United Kingdom, and/or United States of America and which relate to foreign trade controls, export controls, embargoes or international boycotts (applying, without limitation, to the financing, payment, insurance, transportation, delivery or storage of product and/or services) hereinafter referred to as "Trade Sanctions".
- 8.2 Recurring the above circumstances during the performance of the contract, the Society shall be entitled at its sole and absolute discretion:
- (a) to immediately suspend payment or performance of the Services which are the object of the contract until such;
  - (b) time as the Trading Sanctions are in force;
  - (c) to a full disengagement from the obligation affected by the Trading Sanctions, in the event that the inability to fulfill the said obligation persists until the term provided for the fulfilment hereunder, provided that where the relevant obligation relates to payments for activities and/or Services which have already been delivered, the affected payment obligation shall remain only suspended until such time as the Trading Sanctions no longer apply to the payment ; and/or
  - (d) to terminate the contract, without prejudice of the Society's rights pursuant to Article 4.

#### ARTICLE 9

Should any part of these General Conditions be declared invalid, this will not affect the validity of the remaining provisions.

#### ARTICLE 10

When the Society provides its Services to a consumer - i.e. a natural person who does not act within the scope of his business or professional activity - the following provisions do not apply Article 3 (as far as the Society is solely entitled to the authentic interpretation of the Rules); Article 4, (as far as the payment of the fees is also due for Services not

concluded due to causes not attributable to the Interested Party); Article 5 (as far as the exclusion of liability is concerned), and Article 6 (as far as the jurisdiction of a Board of Arbitrators based in Abu Dhabi is concerned).

#### **ARTICLE 11**

- 11.1 The Society and the Interested Party shall promote safety, protect human health and environment and create safe working conditions for their personnel.
- 11.2 The Interested Party shall guarantee that the working environment in which the Society's Surveyor will be required to work is adequate, safe and in all respect compliant with the applicable legislation and Rules and shall adopt all necessary measures to mitigate and/or control any relevant risk.
- 11.3 Furthermore, in accordance with the applicable legislation and Rules, the Interested Party shall provide the Society with complete and detailed information relevant to any actual or potential specific risk existing in the work areas where the Surveyor will be required to operate and relevant to the performance of the Services as well as with any specific safety measure that the Society's Surveyor is requested to comply with.
- 11.4 The Society reserves not to commence and/or to suspend the Services and/or to terminate the contract, claiming compensation for any damage occurred, if it considers that the safety requirements listed in this Article are not satisfactorily met.

# EXPLANATORY NOTE TO PART D

## 1. Reference edition

The reference edition of these Rules is the edition effective from 15 March 2010 issued with Rule Variation TCHU/2010/01 on 23/02/2010.

## 2. Effective date of the requirements

2.1 All requirements in which new or amended provisions with respect to those contained in the reference edition have been introduced are followed by a date shown in brackets.

The date shown in brackets is the effective date of entry into force of the requirements as amended by the last updating. The effective date of all those requirements not followed by any date shown in brackets is that of the reference edition.

2.2 Item 5 below provides a summary of the technical changes from the preceding edition. In general, this list does not include those items to which only editorial changes have been made not affecting the effective date of the requirements contained therein.

## 3. Rule Variations and Corrigenda

Until the next edition of the Rules is published, Rule 5 below provides a summary of the technical changes from the preceding edition. In general, this list does not include those items to which only editorial changes have been made not affecting the effective date of the requirements contained therein.

Until the next edition of the Rules is published, Rule Variations and Corrigenda are not issued.

## 4. Rule subdivision and cross-references

### 4.1 Rule subdivision

The Rules are subdivided into six parts, from A to F.

Part A: Classification and Surveys

Part B: Hull and Stability

Part C: Machinery, Systems and Fire Protection

Part D: Materials and Welding

Part E: Service Notations

Part F: Additional Class Notations

Each Part consists of:

- Chapters
- Sections and possible Appendices
- Articles
- Sub-articles
- Requirements

Figures (abbr. Fig) and Tables (abbr. Tab) are numbered in ascending order within each Section or Appendix.

### 5.2 Cross-references

Examples: Pt A, Ch 1, Sec 1, [3.2.1] or Pt A, Ch 1, App 1, [3.2.1]

- Pt A means Part A

The part is indicated when it is different from the part in which the cross-reference appears. Otherwise, it is not indicated.

- Ch 1 means Chapter 1

The Chapter is indicated when it is different from the chapter in which the cross-reference appears. Otherwise, it is not indicated.

- Sec 1 means Section 1 (or App 1 means Appendix 1)

The Section (or Appendix) is indicated when it is different from the Section (or Appendix) in which the cross-reference appears. Otherwise, it is not indicated.

- [3.2.1] refers to requirement 1, within sub-article 2 of article 3.

Cross-references to an entire Part or Chapter are not abbreviated as indicated in the following examples:

- Part A for a cross-reference to Part A
- Part A, Chapter 1 for a cross-reference to Chapter 1 of Part A.

## 5. Summary of amendments

### Foreword

The date of entry into force of each new or amended item is shown in brackets after the number of the item concerned.



# RULES FOR THE CLASSIFICATION OF FLOATING OFFSHORE UNITS AT FIXED LOCATIONS AND MOBILE OFFSHORE DRILLING UNITS

## Part D **Materials and Welding**

### Chapter 1

---

#### **Chapter 1      GENERAL REQUIREMENTS**



# CHAPTER 1

## GENERAL REQUIREMENTS

### Section 1 GENERAL REQUIREMENTS

1	General	5
1.1	Application	

---

### Section 2 Equipment

1	Offshore mooring chain	6
1.1	General requirements	
1.2	Rolled steel bars	
1.3	Forged steel	
1.4	Cast steel	
1.5	Materials for studs	
1.6	Design and chain manufacture	
1.7	Testing and inspection of finished chain	
1.8	Testing and inspection of accessories	
1.9	Chafing Chain for Single Point Mooring arrangements	

Part D  
**Materials and Welding**

Chapter 1

**GENERAL REQUIREMENTS**

---

**SECTION 1      GENERAL REQUIREMENTS**

**SECTION 2      EQUIPMENT**

## SECTION 1

## GENERAL REQUIREMENTS

### 1 General

mooring chain in Sec 2 of this Chapter are to be complied with.

#### 1.1 Application

##### 1.1.1 (1/1/2022)

The applicable requirements in Pt D of the Rules for the Classification of Ships and the requirements for offshore

## SECTION 2 EQUIPMENT

### 1 Offshore mooring chain

#### 1.1 General requirements

##### 1.1.1 Application (1/7/2017)

This article [1] apply to the materials, design, manufacture and testing of offshore mooring chain and accessories.

Mooring equipment covered comprises common stud and studless links, connecting common links (splice links), enlarged links, end links, detachable connecting links (shackles), end shackles, subsea connectors, swivels and swivel shackles.

Studless link chain is normally deployed only once, being intended for long-term permanent mooring systems with pre-determined design life.

Requirements for chafing chain for single point mooring arrangements are given in [1.9].

##### 1.1.2 Chain grades (1/7/2017)

Depending on the nominal tensile strength of the steels used for manufacture, chains are to be subdivided into five grades, i.e.: R3, R3S, R4, R4S and R5 whose mechanical properties are summarised in Tab 3.

Manufacturers propriety specifications for R4S and R5 may vary subject to design conditions and the acceptance of the Society.

Each Grade is to be individually approved. Approval for a higher grade does not constitute approval of a lower grade.

If it is demonstrated to the satisfaction of the Society that the higher and lower grades are produced to the same manufacturing procedure using the same chemistry and heat treatment, consideration will be given to qualification of a lower grade by a higher. The parameters applied during qualification are not to be modified during production.

##### 1.1.3 Approval of chain Manufacturers (1/7/2017)

Offshore mooring chains are to be manufactured only by works approved by the Society. To this end approval tests are to be carried out, the scope of which is to cover proof and breaking load tests, measurements and mechanical tests including fracture mechanics tests.

Manufacturers are to submit for review and approval the sequence of operations from receiving inspection to shipment as well as details of the following manufacturing processes:

- a) bar heating and bending including method, temperatures, temperature control and recording,
- b) flash welding including current, force, time and dimensional variables as well as control and recording of

parameters, maintenance procedure and programme for welding machine,

- c) flash removal including method and inspection,
- d) stud insertion method, for stud link chain,
- e) heat treatment including furnace types, means of specifying, controlling and recording temperature and chain speed and allowable limits, quenching bath and agitation, cooling method after exit,
- f) proof and break loading including method/machine, means of horizontal support (if applicable), method of measurement and recording,
- g) non-destructive examination procedures,
- h) the manufacturer's surface quality requirement of mooring components is to be submitted,
- i) the manufacturer's procedure for removing and replacing defective links without heat treatment of the entire chain.

For initial approval CTOD tests are to be carried out on the particular mooring grade of material. CTOD tests are to be carried out in accordance with a recognized standard such as BS 7448 Part 1 & BS EN ISO 15653:2010. The CTOD test piece is to be a standard 2 x 1 single edge notched bend piece, test location as shown in Fig 1. The notch of the CTOD specimen is to be located as close to the surface as practicable. The minimum cross section of the test piece is to be 50 x 25mm for chain diameters less than 120mm, and 80 x 40mm for diameters 120mm and above. CTOD specimens are to be taken from both the side of the link containing the weld and from the opposite side. Three links are to be selected for testing, a total of six CTOD specimens. The tests are to be taken at minus 20° C and the lowest CTOD of each set of 3 specimens is to meet the minimum values indicated in Tab 1.

Calibration of furnaces is to be verified by measurement and recording of a calibration test piece with dimensions equivalent to the maximum size of link manufactured.

The manufacturer is to submit a procedure for furnace temperature surveys which is to include the following requirements: The temperature uniformity of furnaces is to be surveyed whenever approval of manufacturer is requested and at least annually during normal operating conditions. Furnaces are to be checked by conveying a monitoring link instrumented with two thermocouples through the furnaces at representative travel speed. One thermocouple is to be attached to the surface of the straight part and one thermocouple is to be imbedded in a drilled hole located at the mid thickness position of the straight part of the calibration block. The time-temperature curves are to show that the temperatures throughout the cross section and the soaking times are within specified limits as given in the heat treatment procedure.

For R4S and R5 chain and accessories, prior to approval, the manufacturer is to have undertaken experimental tests or have relevant supporting data to develop the chain and accessory material. The tests and data may include: fatigue tests, hot ductility tests (no internal flaws are to develop whilst bending in the link forming temperature range),

welding parameter research, heat treatment study, strain age resistance, temper embrittlement study, stress corrosion cracking (SCC) data and hydrogen embrittlement (HE) study, using slow strain test pieces in hydrated environments. Reports indicating the results of experimental tests are to be submitted.

**Table 1: Minimum CTOD test values for chain type (1/7/2017)**

Chain Type	R3 in mm		R3S in mm		R4 in mm		R4S and R5 in mm	
	BM	WM	BM	WM	BM	WM	BM	WM
Stud link	0,20	0,10	0,22	0,11	0,24	0,12	0,26	0,13
Studless	0,20	0,14	0,22	0,15	0,24	0,16	0,26	0,17

**Figure 1 : Location of CTOD test specimens for chain (1/7/2017)**

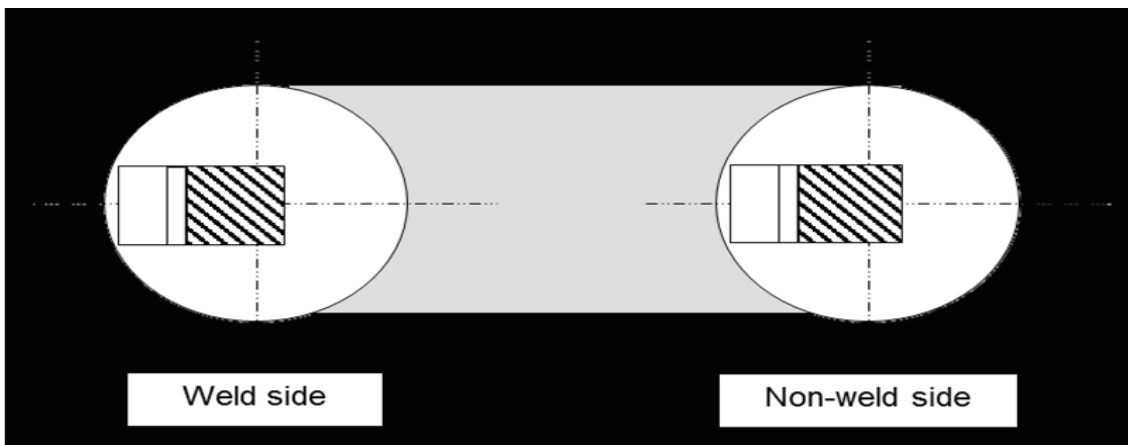

**1.1.4 Chain grades (1/7/2011)**

Chain and accessory manufacturers are to have a documented and effective Quality System approved by the Society. Such a Quality System is required in addition to, and not in lieu of, the witnessing of tests by a Surveyor as specified in [1.2] to [1.5].

**1.1.5 Approval of Rolled Bar steel mills (1/7/2017)**

Bar materials intended for chain and accessories is to be manufactured only by works approved by the Society. The approval is limited to a nominated supplier of bar material. If a chain Manufacturer wishes to use material from a number of suppliers, separate approval tests are to be carried out for each one.

Approval may only be given after successful testing of the completed chain.

Each grade is to be individually approved. Approval for a higher grade does not constitute approval of a lower grade. If it is demonstrated to the satisfaction of the Society that the higher and lower grades are produced to the same manufacturing procedure using the same chemistry and heat treatment, consideration will be given to qualification of a lower grade by a higher. The parameters applied during qualification are not to be modified during production.

The approval is generally limited up to the maximum diameter equal to that of the chain diameter tested. The rolling reduction ratio is to be recorded and is to be at least 5:1 for

R3, R3S, R4, R4S and R5. The rolling reduction ratio used in production can be higher, but should not be lower than that qualified.

The steel maker is to submit a specification of the chemical composition of the bar material, which is to be approved by the Society and by the chain Manufacturer.

The steel maker is to confirm by analysis and testing that the specification is met.

For Grade R4, R4S and R5 chain the steel is to contain a minimum of 0,20 per cent molybdenum.

A heat treatment sensitivity study simulating chain production conditions is to be applied in order to verify mechanical properties and establish limits for temperature and time combinations. All test details and results are to be submitted to the Society.

The bar Manufacturer is to provide evidence that the manufacturing process produces material that is resistant to strain ageing, temper embrittlement and for R3S, R4, R4S and R5, hydrogen embrittlement.

All test details and results are to be submitted to the Society.

**1.1.6 Approval of forges and foundries supplying accessories (1/7/2017)**

Forges and foundries intending to supply finished or semi-finished accessories are to be approved by the Society. A description of manufacturing processes and process con-

trols is to be submitted to the Society. The scope of approval is to be agreed with the Society.

The approval is to be limited to a nominated supplier of forged or cast material. If an accessory manufacturer wishes to use material from a number of suppliers, a separate approval must be carried out for each supplier.

Approval will be given only after successful testing of the completed accessory.

Approval for a higher grade does not constitute approval of a lower grade. If it is demonstrated to the satisfaction of the Society that the higher and lower grades are produced to the same manufacturing procedure using the same steel specification, supplier and heat treatment, consideration will be given to qualification of a lower grade by a higher.

The approval will normally be limited to the type of accessory and the IACS designated mooring grade of material up to the maximum diameter or thickness equal to that of the completed accessory used for qualification unless otherwise agreed by the Society. However for the different accessories that have the same geometry, the tests for initial approval are to be carried out on the one having the lowest reduction ratio.

Qualification of accessory pins to maximum diameters is also required. Individual accessories of complex geometries will be subject to the Society requirements.

Forgings are to have wrought microstructure and the minimum reduction ratio is to be 3 to 1.

The forging reduction ratio, used in the qualification tests, from cast ingot/slab to forged component is to be recorded. The forging reduction ratio used in production can be higher, but should not be lower than that qualified.

The degree of upsetting during qualification is to be recorded and maintained during production. Heat cycling during forging and reheating is to be monitored by the manufacturer and recorded in the forging documentation. The manufacturer is to have a maintenance procedure and schedule for dies and tooling which is to be submitted to the Society.

The forge or foundry is to submit a specification of the chemical composition of the forged or cast material, which must be approved by the Society. For Grade R4, R4S and R5 chain the steel should contain a minimum of 0.20 per cent molybdenum.

Forges and foundries are to provide evidence that the manufacturing process produces material that is resistant to strain ageing, temper embrittlement and for R4S and R5 grades, hydrogen embrittlement. A heat treatment sensitivity study simulating accessory production conditions shall be applied in order to verify mechanical properties and estab-

lish limits for temperature and time combinations. (Cooling after tempering shall be appropriate to avoid temper embrittlement). All test details and results are to be submitted to the Society.

For initial approval CTOD tests are to be carried out on the particular mooring grade of material. Three CTOD tests are to be carried out in accordance with a recognized standard such as BS 7448 Part 1 & BS EN ISO 15653:2010. For rectangular accessories, the CTOD test piece is to be a standard 2 x 1 single edge notched bend specimen of thickness equal to full thickness of material to be tested. Sub-sized specimens can be used subject to approval of the Society. For circular geometries, the minimum cross section of the test piece size is to be 50 x 25mm for accessory diameters less than 120mm, and 80 x 40mm for diameters 120mm and above. The notch of the CTOD specimen is to be located as close to the surface as practicable. The tests are to be taken at minus 20° C and the results submitted for review.

The minimum values of each set of three specimens are at least to meet the requirements as indicated in Tab 2 (same as that of the studless chain material shown in Tab 1).

The geometry of accessories can vary. Fig 2 shows the CTOD location for circular and rectangular cross sections such as those of the D-shackle and accessories fabricated from rectangular sections. The orientation of the specimen is to consider the direction of the grain flow. Fig 2 b) shows two possible sampling positions for CTOD test specimens with notch orientation for rectangular type accessories.

Calibration of furnaces is to be verified by measurement and recording of a calibration test piece with dimensions equivalent to the maximum size of link manufactured. Thermocouples are to be placed both on the surface and in a drilled hole located to the mid thickness position of the calibration block.

The furnace dimensions are to be such as to allow the whole furnace charge to be uniformly heated to the necessary temperature. Temperature uniformity surveys of heat treatment furnaces for forged and cast components are to be carried out according to API Spec 6A/ISO 10423 Annex M or ASTM A991. The initial survey is to be carried out with maximum charge (load) in the furnace. Subsequent surveys are to be carried out annually and may be carried out with no furnace charge. The quench bath maximum temperature and the maximum heat treatment transfer times from furnace to quench are to be established and documented. During production the established quenching parameters are to be followed and records are to be maintained of bath temperatures and transfer times.

For R4S and R5 refer to additional requirements in [1.1.3].

**Table 2: Minimum CTOD test values for accessories (1/7/2017)**

Grade of Accessory	R3 in mm	R3S in mm	R4 in mm	R4S and R5 in mm
CTOD	0,20	0,22	0,24	0,26

Figure 2 : Location of CTOD test specimens: a) Circular type accessory and b) rectangular type accessory, B corresponds to the thickness of material, the grain flow is considered in the longitudinal direction X (1/7/2017)

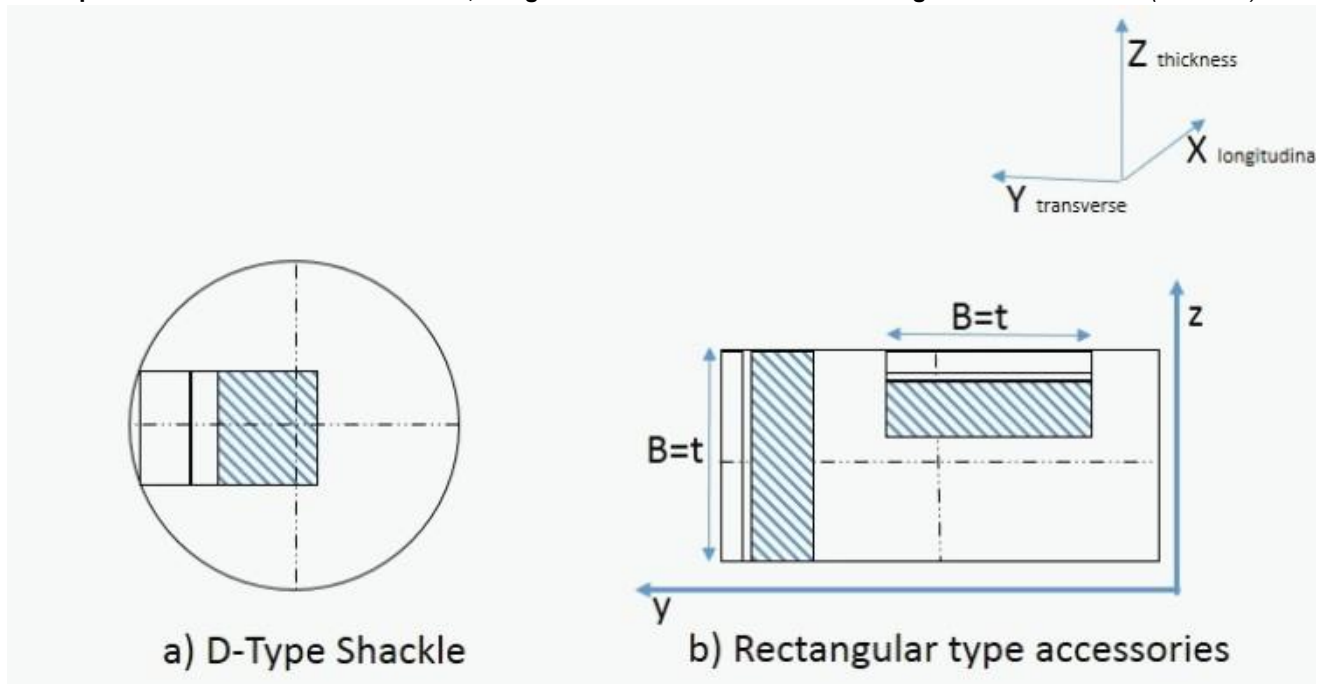

## 1.2 Rolled steel bars

### 1.2.1 Steel manufacture (1/7/2017)

Steels are to be manufactured by basic oxygen, electric furnace or such other process as may be approved on a case-by-case basis. All steels are to be killed and fine grain treated. The austenitic grain size for R3, R3S and R4 is to be 6 or finer in accordance with ASTM E112 or equivalent grain size index in accordance to ISO 643. Measurements for circular sections are to be taken at 1/3 radius.

Steel for bars intended for R4S and R5 chain is to be vacuum degassed. The austenitic grain size is to be 6 or finer in accordance with ASTM E112 or equivalent grain size index in accordance to ISO 643. Measurements for circular sections are to be taken at 1/3 radius.

For R4S and R5 the following information is to be supplied by the bar manufacturer to the mooring chain manufacturer and the results included in the chain documentation:

- Each heat is to be examined for non-metallic inclusions. The level of micro inclusions is to be quantified and assessed in accordance to the national/international standards; to be sure inclusion levels are acceptable for the final product.
- A sample from each heat is to be macro etched according to ASTM E381 or equivalent, to be sure there is no injurious segregation or porosity.
- Hardenability data, according to ASTM A255, or equivalent, is to be supplied with each heat.

### 1.2.2 Chemical composition

For acceptance tests, the chemical composition of ladle samples of each heat is to be determined by the steel maker and is to comply with the approved specification.

### 1.2.3 Mechanical tests (1/7/2017)

Bars of the same nominal diameter are to be presented for testing in batches of 50 tonnes or fraction thereof from the same heat. Test specimens are to be taken from material heat treated in the same manner as intended for the finished chain.

Each heat of Grade R3S, R4, R4S and R5 is to be tested for hydrogen embrittlement. In the case of continuous casting, test samples representing both the beginning and the end of the charge are to be taken. In the case of ingot casting, test samples representing two different ingots are to be taken.

Two tensile test specimens are to be taken from the central region of bar material which has been subjected to the heat treatment cycle intended to be used in production. A specimen with a diameter of 20 mm is preferred (consideration will be given to a diameter of 14 mm).

One of the specimens is to be tested within a maximum of 3 hours after machining (for a 14 mm diameter specimen, the time limit is 1,5 hours). Where this is not possible, the specimen is to be immediately cooled to -60°C after machining and kept at that temperature for a maximum period of 5 days. The second specimen is to be tested after baking at 250°C for 4 hours or, alternatively, 2 hours for a 14 mm diameter specimen.

A slow strain rate less than  $0,0003 \text{ s}^{-1}$  is to be used during the entire test, until fracture occurs. (This is approximately 10 minutes for a 20 mm diameter specimen).

Tensile strength, elongation and reduction of area are to be reported. The acceptance requirement for the test is:

$$Z_1 / Z_2 \geq 0,85$$

where:

$Z_1$  = reduction of area without baking

$Z_2$  = reduction of area after baking

If the requirement  $Z_1 / Z_2 \geq 0,85$  is not achieved, the bar material may be subjected to a hydrogen degassing treatment upon agreement with the Society. New tests are to be performed after degassing.

For all grades, one tensile and three Charpy V-notch specimens are to be taken from each sample selected. The test

specimens are to be taken at approx. one-third radius below the surface, as shown in Fig 3 and prepared in accordance with Part D, Ch 1, Sec 2, [2.1.3] and [4.2] of the Rules for the Classification of Ships.

The results of all tests are to be in accordance with the appropriate requirements of Tab 3.

**Figure 3 : Sampling of steel bars, forgings and castings (1/7/2017)**

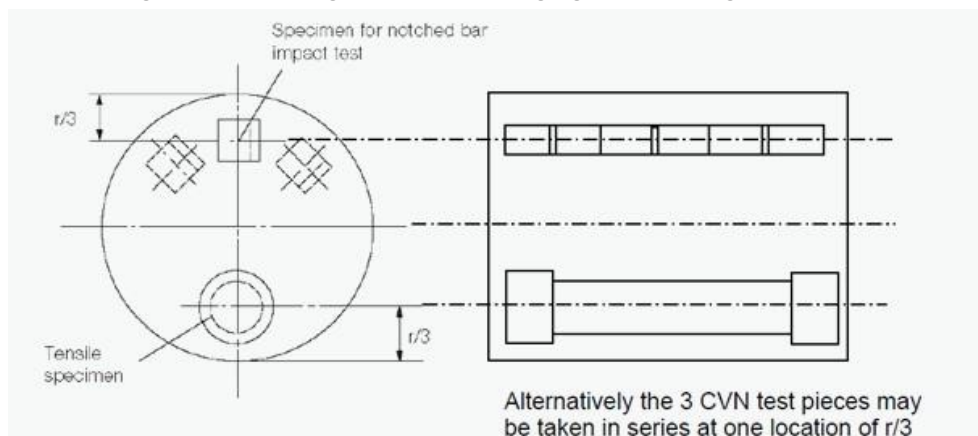

**Table 3 : Mechanical properties of offshore mooring chain and accessories (1/7/2011)**

Grade	Yield stress minimum (1) N/mm <sup>2</sup>	Tensile strength minimum (1) N/mm <sup>2</sup>	Elongation minimum (%)	Reduction (3) or area minimum %	Charpy V-notch impact test		
					Test temp. (°C) (2)	Average energy minimum J	Avg. Energy flash weld minimum J
R3	410	690	17	50	0 -20	60 40	50 30
R3S	490	770	15	50	0 -20	65 45	53 33
R4	580	860	12	50	-20	50	36
R4S (4)	700	960	12	50	-20	56	40
R5 (4)	760	1000	12	50	-20	58	42

(1) Aim value of yield to tensile ratio: 0,92 max.  
(2) At the discretion of the Society, the impact test of Grade R3 and R3S may be carried out at either 0°C or -20°C.  
(3) The reduction of the area of cast steel is to be for Grades R3 and R3S: min. 40%; for R4, R4S and R5: min. 35% (see [1.4.4]).  
(4) Aim maximum hardness for R4S is HB330 and for R5 is HB340.

Re-test requirements for tensile and Charpy impact tests are to be in accordance with Part D, Ch 1, Sec 1, [3.5] of the Rules for the Classification of Ships.

Failure to meet the requirements results in rejection of the batch represented unless it is clearly attributable to improper simulated heat treatment.

#### 1.2.4 Dimensional tolerances

The diameter and roundness are to be within the tolerances specified in Tab 4, unless otherwise agreed.

**Table 4 : Dimensional tolerance of bar stock (1/7/2011)**

Nominal diameter (mm)	Tolerance on diameter (mm)	Tolerance on roundness $d_{max} - d_{min}$ (mm)
less than 25	-0 +1,0	0,60
25 - 35	-0 +1,2	0,80
36 - 50	-0 +1,6	1,10
51 - 80	-0 +2,0	1,50
81 - 100	-0 +2,6	1,95
101 - 120	-0 +3,0	2,25
121 - 160	-0 +4,0	3,00
161 - 210	-0 +5,0	4,00

### 1.2.5 Non-destructive examination and repair (1/7/2017)

Non-destructive examination is to be performed in accordance with recognized Standards such as those indicated below or equivalent. Non-destructive examination procedures, together with rejection/acceptance criteria are to be submitted to the Society.

Magnetic particle testing (MT) of bars:

- ASTM E1444 and ISO 9934

Magnetic Leakage Flux Testing (MLFT):

- JIS Z2319

Eddy current testing (ET) of bars:

- ISO 15549.

Manufacturers are to prepare written procedures for NDE. NDE personnel are to be qualified and certified according to ISO 9712, ACCP or equivalent. Personnel qualification to an employer or responsible agency based qualification scheme as SNT-TC-1A may be accepted if the employer's written practice is reviewed and found acceptable and the Level III is ASNT Level III, ISO 9712 Level III or ACCP Professional Level III and certified in the applicable method. NDE operators are to be qualified to at least level II.

The manufacturer is to ensure that 100 percent of bar material intended for either chain or fittings is to be subjected to ultrasonic examination at an appropriate stage of the manufacture to procedures approved by the Society and to the acceptance criteria required.. The bars are to be free of pipe, cracks and flakes.

. If the end length of the delivered bars is not subjected to UT then it must be agreed between the bar supplier and the chain manufacturer of what length of bar is to be removed from the ends. The details are to be documented in the approval of each bar supplier. Phased array UT procedures may be applied, subject to approval by the Society.

100 percent of the bar material is to be examined by magnetic particle (MT) or eddy current (ET) or Magnetic Leakage Flux Testing (MLFT) methods. Bars are to be free of injurious surface imperfections such as seams, laps and rolled-in mill scale. Provided that their depth is not greater than 1% of the bar diameter, longitudinal discontinuities may be removed by grinding and blending to a smooth contour.

All bars supplied in a machined (peeled) condition are to be 100% visually inspected. The Society may also require 10% inspected with magnetic particle testing (MT) or eddy current testing (ET) or Magnetic Leakage Flux Testing (MLFT), for longitudinal imperfections. The maximum depth of peeling is to be agreed and documented in the approval of each supplier.

The frequency of non-destructive examinations may be reduced at the discretion of the Society provided it is verified by statistical means that the required quality is consistently achieved.

Weld repair of bar is not permitted.

### 1.2.6 Marking

Each bar is to be stamped with the steel grade designation and the charge number (or a code indicating the charge

number) on one of the end surfaces. Other marking methods may be accepted subject to agreement with the Society.

## 1.3 Forged steel

### 1.3.1 Manufacture (1/7/2017)

Forged steels used for the manufacture of accessories are to be in compliance with approved specifications and the submitted tests reports approved by the Society. Steel is to be manufactured by basic oxygen, electric furnace or such other process as may be specially approved. All steel is to be killed and fine grain treated. The austenitic grain size for R3, R3S and R4 is to be 6 or finer in accordance with ASTM E112 or equivalent grain size index in accordance to ISO 643. Measurements for circular sections are to be taken at 1/3 radius. Measurements for non-circular sections are to be taken at 1/4t.

Steel for forgings intended for R4S and R5 chain is to be vacuum degassed.

The austenitic grain size is to be 6 or finer in accordance with ASTM E112 or equivalent grain size index in accordance to ISO 643. Measurements for circular sections are to be taken at 1/3 radius. Measurements for non-circular sections are to be taken at 1/4t.

For steel intended for R4S and R5 accessories the following information is to be supplied by the steel manufacturer to the mooring accessory manufacturer and the results included in the accessory documentation:

- a) Each heat is to be examined for non-metallic inclusions. The level of micro inclusions is to be quantified and assessed in accordance with the national/international standards, to be sure inclusion levels are acceptable for the final product.
- b) A sample from each heat is to be macro-etched according to ASTM E381 or equivalent, to be sure there is no injurious segregation or porosity.
- c) Hardenability data, according to ASTM A255, or equivalent, is to be supplied with each heat.

### 1.3.2 Chemical composition

The requirements in [1.2.2] apply.

### 1.3.3 Heat treatment

Finished forgings are to be properly heat treated in compliance with the specifications submitted and approved.

### 1.3.4 Mechanical properties (1/7/2011)

When properly heat treated, forgings are to comply with the mechanical properties given in Tab 3.

### 1.3.5 Mechanical tests (1/7/2017)

For test sampling, forgings of similar dimensions (diameters do not differ by more than 25mm) originating from the same heat treatment charge and the same heat of steel are to be combined into one test unit. From each test unit one tensile and three impact test specimens are to be taken and tested in accordance with Part D, Ch 1, Sec 2 of the Rules for the Classification of Ships. For the location of the test specimens see Fig 3.

Each heat of Grade R3S, R4, R4S and R5 is to be tested for hydrogen embrittlement.

In case of continuous casting, test samples representing both the beginning and the end of the charge are to be taken. In case of ingot casting, test samples representing two different ingots are to be taken.

Two (2) tensile test specimens are to be taken from the central region of forged material which has been subjected to the heat treatment cycle intended to be used in production. A specimen with a diameter of 20 mm is preferred (consideration will be given to a diameter of 14 mm).

One of the specimens is to be tested within a maximum of 3 hours after machining (for a 14 mm diameter specimen, the time limit is 1½ hours). Where this is not possible, the specimen is to be immediately cooled to -60°C after machining and kept at that temperature for a maximum period of 5 days.

The second specimen is to be tested after baking at 250°C for 4 hours, alternatively 2 hours for 14 mm diameter specimen.

A slow strain rate  $< 0,0003 \text{ s}^{-1}$  is to be used during the entire test, until fracture occurs (this is approximately 10 minutes for the 20 mm diameter specimen). Tensile strength, elongation and reduction of area are to be reported.

The acceptance requirement for the test is:

$$Z1 / Z2 \geq 0.85$$

where:

Z1 = Reduction of area without baking

Z2 = Reduction of area after baking

If the requirement  $Z1 / Z2 \geq 0.85$  is not achieved, the bar material may be subjected to a hydrogen degassing treatment after agreement with the Society. New tests are to be performed after degassing.

### 1.3.6 Non-destructive examination and repair (1/7/2017)

Non-destructive examination is to be performed in accordance with recognized standards, such as those indicated below or equivalent. The non-destructive examination procedures, together with rejection/acceptance criteria are to be submitted to the Society.

Magnetic particle testing (MT) of forgings:

- EN 10228-1, ASTM A275, using wet continuous magnetization technique

Ultrasonic testing (UT) of forgings:

- EN 10228-3, ASTM A388, ISO 13588

Manufacturers are to prepare written procedures for NDE. NDE personnel are to be qualified and certified according to ISO 9712, ACCP or equivalent. Personnel qualification to an employer or responsible agency based qualification scheme as SNT-TC-1A may be accepted if the employer's written practice is reviewed and found acceptable and the Level III is ASNT Level III, ISO 9712 Level III or ACCP Professional Level III and certified in the applicable method. NDE operators are to be qualified to at least level II.

Forgings are to be subjected to one hundred percent ultrasonic examination at an appropriate stage of manufacture

and in compliance with the standard submitted and approved.

Defects on non-machined surfaces may be removed by grinding to a depth of 5% of the nominal diameter. Grinding is not permitted on machined surfaces, except for slight inspection grinding on plane surfaces to a maximum depth of 0.8 mm in order to investigate spurious indications. Welding repairs are not permitted.

### 1.3.7 Marking

Marking is to be similar to that specified in [1.2.6].

## 1.4 Cast steel

### 1.4.1 Manufacture (1/7/2017)

Cast steel used for the manufacture of accessories are to be in compliance with approved specifications and the submitted tests reports approved by the Society. Steel is to be manufactured by basic oxygen, electric furnace or such other process as may be specially approved. All steel is to be killed and fine grain treated. The austenitic grain size for R3, R3S and R4 is to be 6 or finer in accordance with ASTM E112 or equivalent grain size index in accordance to ISO 643. Measurements for circular sections are to be taken at 1/3 radius. Measurements for non-circular sections are to be taken at 1/4t.

Steel for castings intended for R4S and R5 accessories is to be vacuum degassed.

The austenitic grain size is to be 6 or finer in accordance with ASTM E112 or equivalent grain size index in accordance to ISO 643. Measurements for circular sections are to be taken at 1/3 radius. Measurements for non-circular sections are to be taken at 1/4t.

For steel intended for R4S and R5 accessories the following information is to be obtained and the results included in the accessory documentation:

- Each heat is to be examined for non-metallic inclusions. The level of micro inclusions is to be quantified and assessed in accordance to the national/international standards; to be sure inclusion levels are acceptable for the final product.
- A sample from each heat is to be macro etched according to ASTM E381 or equivalent, to be sure there is no injurious segregation or porosity.
- Hardenability data, according to ASTM A255, or equivalent, is to be supplied with each heat.

### 1.4.2 Chemical composition

The requirements in [1.2.2] apply.

### 1.4.3 Heat treatment

All castings are to be properly heat treated in compliance with the specifications submitted and approved.

### 1.4.4 Mechanical properties (1/7/2011)

Castings are to comply with the mechanical properties given in Tab 3. The acceptance requirement for reduction of area is, however, reduced to 40 percent for grades R3 and R3S, and 35 percent for grades R4, R4S and R5.

#### 1.4.5 Mechanical tests

For test sampling, castings of similar dimensions originating from the same heat treatment charge and the same heat of steel are to be combined into one test unit. From each test unit, one tensile and three impact test specimens are to be taken and tested. For the location of the test specimens, see Fig 3.

#### 1.4.6 Non-destructive examination and repair (1/7/2017)

Non-destructive examination is to be performed in accordance with recognized standards, such as those indicated below or equivalent. The non-destructive examination procedures, together with rejection/acceptance criteria are to be submitted to the Society.

Magnetic particle testing (MT) of castings:

- ASTM E709, using wet continuous magnetisation technique

Ultrasonic testing (UT) of castings:

- ASTM A609, ISO 13588

Manufacturers are to prepare written procedures for NDE. NDE personnel are to be qualified and certified according to ISO 9712, ACCP or equivalent. Personnel qualification to an employer or responsible agency based qualification scheme as SNT-TC-1A may be accepted if the employer's written practice is reviewed and found acceptable and the Level III is ASNT Level III, ISO 9712 Level III or ACCP Professional Level III and certified in the applicable method. NDE operators are to be qualified to at least level II.

Castings are to be subjected to one hundred percent ultrasonic examination in compliance with the standard submitted and approved.

Defects on non-machined surfaces may be removed by grinding to a depth of 5% of the nominal diameter. Grinding is not permitted on machined surfaces, except for slight inspection grinding on plane surfaces to a maximum depth of 0.8 mm in order to investigate spurious indications.

Where the repair entails removal of more than 5% of the diameter or thickness, the defective area is to be repaired by welding. The excavations are to be suitably shaped to allow good access for welding. The resulting grooves are to be subsequently ground smooth and complete elimination of the defective material is to be verified by NDE.

Weld repairs are classified as major or minor. A weld repair is considered major when the depth of the groove prepared for welding exceeds 25% of the diameter/thickness or 25 mm, whichever is smaller. All other weld repairs are considered minor.

Major weld repairs require approval before the repair is commenced. Proposals for major repairs are to be accompanied by sketches or photographs showing the extent and positions of the repairs. A grain refining heat treatment is to be given to the whole casting prior to major repairs. A post weld heat treatment or repeat of original heat treatment of castings is to be carried out.

Minor and major weld repairs are to be recorded on sketches or photographs showing the extent and positions of the repairs.

All weld repairs are to be done by qualified welders using qualified procedures.

Welders are to be qualified according to ISO 9606, ASME IX, ASTM A488 or equivalent.

Procedures are to be qualified according to ISO 15614, ASME IX, ASTM A488 or equivalent with the following additional requirements: Charpy V notch impact tests with notch locations in weld metal, fusion line and heat affected zone + 2 mm and + 5 mm from fusion line, respectively. Test results are to meet the requirements specified for the parent metal.

#### 1.4.7 Marking

Marking is to be similar to that specified in [1.2.6].

### 1.5 Materials for studs

#### 1.5.1 (1/7/2011)

Studs intended for stud link chain cable are to be made of steel corresponding to that of the chain or in compliance with the specifications submitted and approved. In general, the carbon content is not to exceed 0,25% if the studs are to be welded in place.

### 1.6 Design and chain manufacture

#### 1.6.1 Design (1/1/2023)

Drawings accompanied by design calculations, giving showing the design of chain and accessories made by or supplied through the chain Manufacturer are to be submitted for approval. Typical designs are given in ISO 1704:2008.

For Studless chain the shape and proportions are to comply with the requirements of this article [1]. Other studless proportions are to be specially approved. It should be considered that new or non-Standard designs of chain, shackles or fittings, may require a fatigue analysis and possible performance, fatigue or corrosion fatigue testing.

In addition, for stud link chain, drawings showing the detailed design of the stud are to be submitted for information. The stud is to give an impression in the chain link which is sufficiently deep to secure the position of the stud, but the combined effect of shape and depth of the impression is not to cause any harmful notch effect or stress concentration in the chain link.

Machining of Kenter shackles is to result in fillet radius min. 3 percent of nominal diameter.

#### 1.6.2 Chain cable manufacturing process (1/7/2017)

Offshore mooring chains are to be manufactured in continuous lengths by flash butt welding and are to be heat treated in a continuous furnace; batch heat treatment is not permitted, except in special circumstances where short lengths of chain are delivered, such as chafing chain (Ref. to [1.9]).

The use of joining shackles to replace defective links is subject to the written approval of the end purchaser in terms of the number and type permitted. The use of connecting common links is restricted to 3 links in each 100 m of chain.

**1.6.3 Chain cable manufacturing process records (1/7/2017)**

Records of bar heating, flash welding and heat treatment are to be made available for inspection by the Surveyor.

**a) Bar heating**

Bars for links are to be heated by electric resistance, induction or in a furnace.

For electric resistance heating or induction heating, the heating phase is to be controlled by an optical heat sensor.

The controls are to be checked at least once every 8 hours and records made.

For furnace heating, the heat is to be controlled and the temperature continuously recorded using thermocouples in close proximity to the bars. The controls are to be checked at least once every 8 hours and records made.

**b) Flash welding of chain cable**

The following welding parameters are to be controlled during welding of each link:

- 1) platen motion,
- 2) current as a function of time,
- 3) hydraulic pressure.

The controls are to be checked every 4 hours and records made.

**c) Heat treatment of chain cable**

Chains are to be austenitized, above the upper transformation temperature, at a combination of temperature and time within the limits established.

When applicable, chains are to be tempered at a combination of temperature and time within the limits established. Cooling after tempering are to be appropriate to avoid temper embrittlement.

Temperature and time or temperature and chain speed are to be monitored and continuously recorded.

Grain determination is to be made for the final product. The austenitic grain size for R3, R3S, R4, R4S and R5 is to be 6 or finer in accordance with ASTM E112 or equivalent grain size index in accordance to ISO 643. Measurements for circular sections are to be taken at surface, 1/3 radius and centre for the base material, HAZ and weld.

**1.6.4 Mechanical properties (1/7/2011)**

The mechanical properties of finished chain and accessories are to be in accordance with Tab 3.

For the location of test specimens, see Fig 3 and Fig 4.

**1.6.5 Proof and breaking test loads**

Chain and accessories are to withstand the proof and break test loads given in Tab 5.

**Figure 4 : Sampling of chain links**

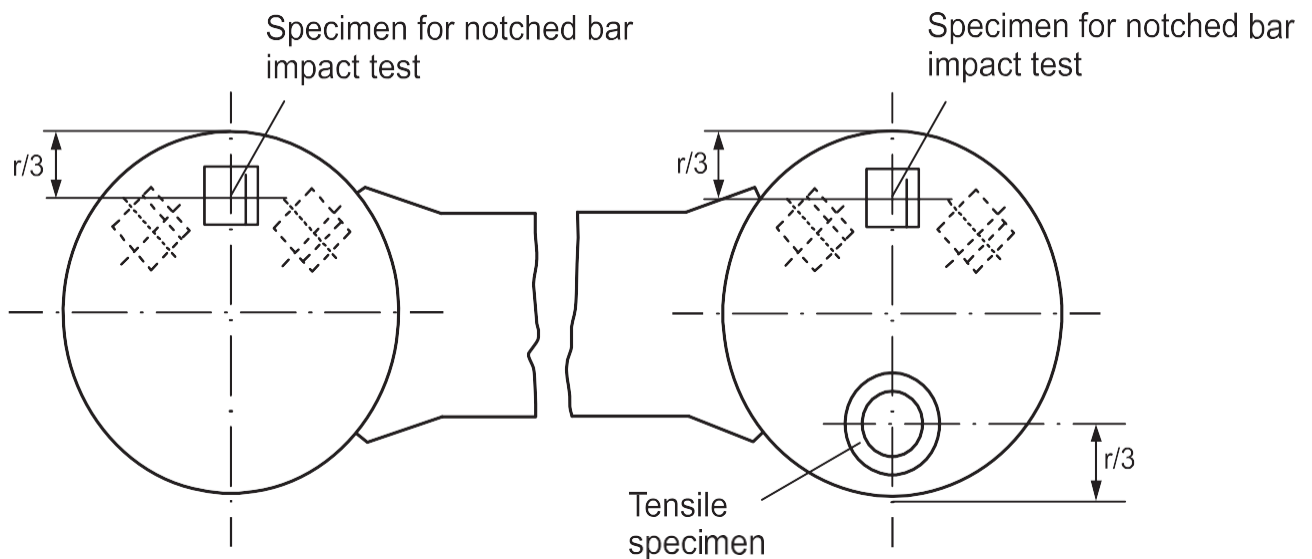

**Table 5 : Formulas for proof and break test loads, weight and length over 5 links (1/7/2011)**

Test Load, in kN	Grade R3 Stud Link	Grade R3S Stud Link	Grade R4 Stud Link	Grade R4S Stud Link	Grade R5 Stud Link
Proof	0,0148d <sup>2</sup> (44-0,08d)	0,0180d <sup>2</sup> (44-0,08d)	0,0216d <sup>2</sup> (44-0,08d)	0,0240d <sup>2</sup> (44-0,08d)	0,0251d <sup>2</sup> (44-0,08d)
Break	0,0223d <sup>2</sup> (44-0,08d)	0,0249d <sup>2</sup> (44-0,08d)	0,0274d <sup>2</sup> (44-0,08d)	0,0304d <sup>2</sup> (44-0,08d)	0,0320d <sup>2</sup> (44-0,08d)
Test Load, in kN	Grade R3 Studless	Grade R3S Studless	Grade R4 Studless	Grade R4S Studless	Grade R5 Studless
Proof	0,0148d <sup>2</sup> (44-0,08d)	0,0174d <sup>2</sup> (44-0,08d)	0,0192d <sup>2</sup> (44-0,08d)	0,0213d <sup>2</sup> (44-0,08d)	0,0223d <sup>2</sup> (44-0,08d)
Break	0,0223d <sup>2</sup> (44-0,08d)	0,0249d <sup>2</sup> (44-0,08d)	0,0274d <sup>2</sup> (44-0,08d)	0,0304d <sup>2</sup> (44-0,08d)	0,0320d <sup>2</sup> (44-0,08d)

Test Load, in kN	Grade R3 Stud Link	Grade R3S Stud Link	Grade R4 Stud Link	Grade R4S Stud Link	Grade R5 Stud Link
Chain Weight, in kg/m	Stud link = $0,0219 d^2$				
Chain Weight, in kg/m	Studless chain Weight calculations for each design are to be submitted				
Pitch Length	Five link measure				
Minimum	22d				
Maximum	22,55d				

**1.6.6 Freedom from defects**

All chains are to have a workmanlike finish consistent with the method of manufacture and to be free from defects. Each link is to be examined in accordance with [1.7.5] using approved procedures.

**1.6.7 Dimensions and dimensional tolerances (1/1/2023)**

The shape and proportion of links and accessories are to conform to ISO 1704:2008 or the designs approved on a case-by-case basis.

The following tolerances are applicable to links:

- a) The negative tolerance on the nominal diameter measured at the crown:
  - up to 40 mm nominal diameter: - 1 mm
  - over 40 mm up to 84 mm nominal diameter: - 2 mm
  - over 84 mm up to 122 mm nominal diameter: - 3 mm
  - over 122 mm up to 152 mm nominal diameter: - 4 mm
  - over 152 mm up to 184 mm nominal diameter: - 6 mm
  - over 184 mm up to 210 mm nominal diameter: - 7,5 mm

The cross sectional area at the crown must have no negative tolerance. For diameters of 20 mm or greater, the plus tolerance may be up to 5 percent of the nominal diameter. For diameters less than 20 mm the plus toler-

ance is to be agreed with the Society at the time of approval.

The cross sectional area at the crown is to be calculated using the average of the diameters with negative tolerance and plus tolerance, measurements are to be taken from at least two locations approximately 90 degrees apart.

- b) Diameter measured at locations other than the crown:
  - The diameter is to have no negative tolerance. The plus tolerance may be up to 5 percent of the nominal diameter except at the butt weld where it is to be in accordance to manufacturer's specification, which is to be agreed with the Society. For diameters less than 20 mm, the plus tolerance is to be agreed with the Society at the time of approval.
- c) The allowable manufacturing tolerance on a length of five links is + 2,5 percent, but may not be negative.
- d) All other dimensions are subject to a manufacturing tolerance of  $\pm 2,5$  percent, always provided that all parts fit together properly.
- e) The tolerances for stud link and studless common links are to be measured in accordance with Tab 6.
- f) For stud link chains studs must be located in the links centrally and at right angles to the sides of the link. The following tolerances in Tab 6 are acceptable provided that the stud fits snugly and its ends lie flush against the inside of the link.

**Table 6 : Stud link and studless common link, proportions dimensions and tolerances (1/7/2011)**

a) Stud link					
	Designation (1)	Description	Nominal dimension of the link	Minus tolerance	Plus tolerance
	a	Link length	6d	0,15d	0,15d
	b	Link half length	a*/2	0,1d	0,1d
	c	Link width	3,6d	0,09d	0,09d
	e	Stud angular misalignment	0 degrees	4 degrees	4 degrees
	R	Inner radius	0,65 d	0	----
(1) Dimension designation is shown in above figure Note 1: d = Nominal diameter of chain, a* = Actual link length Note 2: The internal link radii (R) and external radii should be uniform					
b) Studless					
	Designation (1)	Description	Nominal dimension of the link	Minus tolerance	Plus tolerance
	a	Link length	6d	0,15d	0,15d
	b	Link width	3,35d	0,09d	0,09d
	R	Inner radius	0,60 d	0	----
(1) Dimension designation is shown in above figure Note 1: d = Nominal diameter of chain. Note 2: Other dimension ratios are subject to special approval. Note 3: The internal link radii (R) and external radii should be uniform.					

### **1.6.8 Stud link chain - welding of studs (1/7/2011)**

A welded stud may be accepted for grade R3 and R3S chains. Welding of studs in grades R4, R4S and R5 chain is not permitted unless specially approved.

Where studs are welded into the links this is to be completed before the chain is heat treated.

The stud ends are to be a good fit inside the link and the weld is to be confined to the stud end opposite to the flash butt weld. The full periphery of the stud end is to be welded unless otherwise approved.

Welding of studs both ends is not permitted unless specially approved.

The welds are to be made by qualified welders using an approved procedure and low-hydrogen approved consumables.

The size of the fillet weld is to be at least the minimum as per API Specification 2F.

The welds are to be of good quality and free from defects such as cracks, lack of fusion, gross porosity and undercuts exceeding 1 mm.

All stud welds are to be visually examined. At least 10 per cent of all stud welds within each length of chain are to be examined by dye penetrant or magnetic particles after proof testing. If cracks or lack of fusion are found, all stud welds in that length are to be examined.

### **1.6.9 Connecting common links (splice links) (1/7/2011)**

Single links to substitute for test links or defective links without the necessity for re-heat treatment of the whole length are to be made in accordance with an approved procedure. Separate approvals are required for each grade of chain and the tests are to be carried out on the maximum size of chain for which approval is sought.

The Manufacture and heat treatment of the connecting common link is not to affect the properties of the adjoining links. The temperature reached by these links is nowhere to exceed 250°C.

Each link is to be subjected to the appropriate proof load and non-destructive examination as detailed in Tab 5 and [1.7.5]. A second link is to be made identical to the connecting common link; this link is to be tested and inspected as per [1.7.4] and [1.7.5].

Each connecting common link is to be marked either on the stud for stud link chain or, on the outer straight length on the side opposite the flash butt weld for Studless chain.

This marking is to be in accordance with [1.7.7] plus a unique number for the link. The adjoining links are also to be marked on the studs or straight length as above.

## **1.7 Testing and inspection of finished chain**

### **1.7.1 General (1/7/2017)**

This item [1.7] applies to but is not limited to finished chain cable such as common stud and studless links, end links, enlarged end links and connecting common links (splice links).

All chain is to be subjected to proof load tests, sample break load tests and sample mechanical tests after final heat treat-

ment in the presence of a the Society Surveyor. Where the Manufacturer has a procedure to record proof loads and the Surveyor is satisfied with the adequacy of the recording system, he need not witness all proof load tests. The Surveyor is to satisfy himself that the testing machines are calibrated and maintained in a satisfactory condition.

Prior to inspection the chain is to be free from scale, paint or other coating and is to have a suitably prepared surface as per the applied NDE testing standard. The chain is to be sand- or shot blasted to meet this requirement.

### **1.7.2 Proof and break load tests (1/7/2017)**

The entire length of chain is to withstand the proof load specified in Tab 5 without fracture and is not to crack in the flash weld. The load applied is not to exceed the proof load by more than 10% when stretching the chain. Where plastic straining is used to set studs, the applied load is not to be greater than that qualified in approval tests.

A break-test specimen consisting of at least 3 links is to be either taken from the chain or produced at the same time and in the same manner as the chain. The test frequency is to be based on tests at sampling intervals according to Tab 7 provided that every cast is represented. Each specimen is to be capable of withstanding the break load specified without fracture and is not to crack in the flash weld. It is considered acceptable if the specimen is loaded to the specified value and maintained at that load for 30 seconds.

For chain diameters over 100mm, alternative break-test proposals to the above breaktest will be considered whereby a one link specimen is used. Alternatives are to be approved by the Classification Society, every heat is to be represented, the test frequency is to be in accordance with Tab 7, and it is to be demonstrated and proven that the alternative test represents an equivalent load application to the three link test.

If the loading capacity of the testing machine is insufficient, an alternative load testing machine is to be used that does have sufficient capacity (e.g. two loading machines in parallel) provided the testing and calibration procedure are agreed with the Society.

### **1.7.3 Dimensions and dimensional tolerances (1/7/2017)**

After proof load testing, measurements are to be taken on at least 5 per cent of the links in accordance with [1.6.7].

The entire chain is to be checked for the length, five links at a time. By means of the five-link check the first five links are to be measured. At least two links from the previous five-links set are to be included in the next set of five, and so on. This procedure is to be followed for the entire chain length. The measurements are to be taken preferably while the chain is loaded to 5 - 10 % of the minimum proof load.

The tolerances for the 5 link measurements are indicated in Tab 6, any deviations from the 5 link tolerances are to be agreed by the client and the Society.

The links held in the end blocks may be excluded from this measurement.

Chain dimensions are to be recorded and the information retained on file.

#### 1.7.4 Mechanical tests (1/7/2017)

Links of samples detached from finished, heat treated chain are to be sectioned for determination of mechanical properties. A test unit is to consist of one tensile and nine impact specimens. The tensile specimen is to be taken in the side opposite the flash weld. Three impact specimens are to be taken across the flash weld with the notch centred in the middle. Three impact specimens are to be taken across the unwelded side and three impact specimens are to be taken from the bend region.

The test frequency is to be based on tests at sampling intervals according to Tab 7 provided that every cast is represented. Mechanical properties are to be as specified in Tab 3.

The frequency of impact testing in the bend may be reduced at the discretion of the Society, provided it is verified by statistical means that the required toughness is consistently achieved.

Hardness tests are to be carried out on finished chain. The frequency and locations are to be agreed with the Society. The recorded values are for information only and used as an additional check to verify that the heat treatment process has been stable during the chain production.

**Table 7 : Frequency of break and mechanical tests (1/7/2017)**

Nominal chain diameter (mm)	Maximum sampling interval (m)
Min-48	91
49-60	110
61-73	131
74-85	152
86-98	175
99-111	198
112-124	222
125-137	250
138-149	274
150-162	297
163-175	322
176-186	346
187-198	370
199-210	395
211-222	420

#### 1.7.5 Non-destructive examination after proof load testing (1/7/2017)

All surfaces of every link are to be visually examined. Burrs, irregularities and rough edges are to be contour ground. Links are to be free from mill defects, surface cracks, dents and cuts, especially in the vicinity of the zone gripped by clamping dies during flash welding. Studs are to be securely

fastened. Chain is to be positioned in order to have good access to all surfaces.

In order to allow optimal access to the surface area it is recommended that chain be hung in the vertical position, however access to inspect the interlink area may only be possible with the chain in the horizontal position.

Testing is to be performed in accordance with a recognized Standard and the procedures, together with acceptance/rejection criteria are to be submitted to the Society for review.

Manufacturers is to prepare written procedures for NDE. NDE personnel are to be qualified and certified according to ISO 9712, ACCP or equivalent. Personnel qualification to an employer or responsible agency based qualification scheme as SNT-TC-1A may be accepted if the employer's written practice is reviewed and found acceptable and the Level III is ASNT Level III, ISO 9712 Level III or ACCP Professional Level III and certified in the applicable method. NDE operators are to be qualified to at least level II.

Magnetic particles are to be employed to examine the flash welded area including the area gripped by the clamping dies.

Procedures are to be submitted to the Society for approval.

Procedures and equipment in accordance with those approved are to be used. Frequency of examination is to be every link. Additionally, 10% of links are to be tested on all accessible surfaces. Link surfaces and the surface at the flash weld are to be free from cracks, lack of fusion and gross porosity. Testing is to be performed in accordance with ASTM E709 or another recognized standard (e.g. ISO 9934) using wet continuous fluorescent magnetization technique. Non fluorescent techniques can be accepted in special cases where the standard inspection procedures are impractical.

Links are to be free from:

- relevant linear indications exceeding 1.6 mm in transverse direction
- relevant linear indications exceeding 3.2 mm in longitudinal direction
- relevant non-linear indications exceeding 4.8 mm.

Ultrasonic tests are to be employed to examine the flash weld fusion.

Procedures are to be submitted to the Society for approval.

Procedures and equipment used are to be in accordance with those approved. On-site calibration standards for chain configurations are to be approved.

The frequency of examination is to be every link.

The flash weld is to be free from defects causing ultrasonic back reflections equal to or greater than the calibration standard.

The flash butt welds are to be ultrasonic tested (UT) in accordance with ASTM E587 or another recognized standard using single probe, angle-beam shear waves in the range from 45° to 70°.

Single probe technique has limitations as far as testing of the central region is concerned and the flash weld imperfections such as flat spots may have poor reflectivity. Where

it is deemed necessary, detectability of imperfections may need to be carried out by using a tandem technique, TOFD or phased array.

Stud welds, if used, are to be visually inspected. The toes of the fillets are to have a smooth transition to the link with no undercuts exceeding 1.0 mm. Additionally, at least 10% of the stud welds distributed through the length are to be dye penetrant tested according to ASTM E1417 or magnetic particle tested according to ASTM E1444 or equivalent. Cracks, lack of fusion or gross porosity are not acceptable. If defects are found, testing is to be extended to all stud welds in that length.

#### 1.7.6 Retest, rejection and repair criteria (1/7/2017)

- a) If the length over 5 links is short, the chain may be stretched by loading above the proof test load specified provided that the applied load is not greater than that approved and that only random lengths of the chain need stretching.

If the length exceeds the specified tolerance, the over-length chain links are to be cut out and item (b) applies.

- b) If single links are found to be defective or not to meet other applicable requirements, they may be cut out and a connecting common link inserted in their place. The individual heat treatment and inspection procedure for connecting common links are subject to the Society approval.

Other methods of repair are subject to the written approval of the Society and of the end purchaser.

Weld repair of chain is not permitted.

- c) If a crack, cut or defect in the flash weld is found by visual or magnetic particle examination, it is to be ground down no more than 5% of the link diameter in depth and streamlined so that there are no sharp contours. The final dimensions are to conform to the agreed standard.
- d) If indications of interior of flash weld defects, in reference to the accepted calibration standards are detected during ultrasonic examination, item (b) applies.
- e) If link diameter, length, width and stud alignment do not conform to the required dimensions, these are to be compared to the dimensions of 40 more links, 20 on each side of the affected link. If a single particular dimension fails to meet the required dimensional tolerance in more than 2 of the sample links, all links are to be examined. Item (b) applies.
- f) If a break load test fails, the Surveyor is to be promptly notified and a thorough examination is to be jointly carried out to identify the cause of failure. Two additional break test specimens representing the same sampling length of chain are to be subjected to the break load test. Subject to the satisfactory outcome of the additional tests and the results of the failure investigation, it is to be decided what lengths of chain can be accepted. Failure of either or both additional tests results in rejection of the sampling length of chain represented and item (b) applies.
- g) If a link fails during proof load testing, the Surveyor is to be promptly notified and a thorough examination is to

be jointly carried out to identify the probable cause of failure. In the event that two or more links in the proof loaded length fail, this section of proof loaded length is to be rejected. The above failure investigation is to be carried out especially with regard to the presence in other lengths of factors or conditions thought to be causes of failure.

In addition to the above failure investigation, a break test specimen is to be taken from each side of the one failed link, and subjected to the breaking test.

Where multiple chains are produced simultaneously it is recognised that the preceding flash butt welded link and subsequent flash butt welded link will be on an alternative chain length or the other end of the chain length. In such cases the Society may require that two additional break tests are to be taken from the lengths of chain that include the preceding and subsequent welded links.

Subject to the satisfactory outcome of both break tests and the results of the failure investigation, it is to be decided what length of chain can be considered for acceptance. Failure of either or both breaking tests results in rejection of the same proof loaded length.

Replacement of defective links is to be in accordance with item (b).

If the investigation identifies defects in the flash butt weld or a lower strength flash weld "a glue-weld" is found, additional NDT such as phased array UT is to be carried out to identify if other links are affected. A full assessment of the flash butt welding machine is to be carried out, together with assessment of the condition of the bar ends prior to welding.

- h) Re-test requirements for tensile and Charpy impact tests are to be in accordance with Part D, Ch 1, Sec 1, [3.5] of the Rules for the Classification of Ships.

Failure to meet the requirements results in rejection of the sampling length represented and item (b) applies.

#### 1.7.7 Marking

The chain is to be marked at the following places:

- at each end,
- at intervals not exceeding 100 m,
- on connecting common links,
- on links next to shackles or connecting common links.

All marked links are to be stated on the certificate, and the marking is to make it possible to recognise the leading and tail end of the chain. In addition to the above required marking, the first and last common link of each individual charge used in the continuous length are to be traceable and adequately marked.

The marking is to be permanent and legible throughout the expected lifetime of the chain.

The chain is to be marked on the studs as follows:

- chain grade,
- certificate number,
- TASNEEF stamp.

The certificate number may be replaced by an abbreviation or equivalent. If so, this is to be stated on the certificate.

The chain certificate is to contain information on the number and location of connecting common links. The certificate number and replacement link number may be replaced by an abbreviation or equivalent. If so, this is to be stated on the certificate.

### 1.7.8 Documentation

A complete Chain Inspection and Testing Report in booklet form is to be provided by the chain Manufacturer for each continuous chain length. This booklet is to include all dimensional checks, test and inspection reports, non-destructive examination reports, process records, photographs as well as any nonconformity, corrective action and repair work.

Individual certificates are to be issued for each continuous single length of chain.

All accompanying documents, appendices and reports are to carry reference to the original certificate number.

The Manufacturer is responsible for storing all documentation produced, in a safe and retrievable manner, for a period of at least 10 years.

## 1.8 Testing and inspection of accessories

### 1.8.1 General (1/7/2017)

This item [1.8] applies to but is not limited to mooring equipment accessories such as detachable connecting links (shackles), detachable connecting plates (triplates), end shackles, swivels and swivel shackles and subsea connectors.

All accessories are to be subjected to proof load tests, sample break load tests and sample mechanical tests after final heat treatment in the presence of a Surveyor. Where the Manufacturer has a procedure to record proof loads and the Surveyor is satisfied with the adequacy of the recording system, he need not witness all proof load tests. The Surveyor is to satisfy himself that the testing machines are calibrated and maintained in a satisfactory condition.

Prior to testing and inspection the chain accessories are to be free from scale, paint or other coating.

For accessory production a Manufacturing Procedure Specification (MPS) is to be submitted to the Society that details all critical aspects of accessory production, casting, forging, heat treating (including arrangement and spacing of components in the heat treatment furnaces), quenching, mechanical testing, proof and break loading and NDE.

### 1.8.2 Proof and break load tests (1/7/2017)

- All accessories are to be subjected to the proof load specified for the corresponding stud link chain.
- Chain accessories are to be tested at the break load prescribed for the grade and size of chain for which they are intended. At least one accessory out of every batch or every 25 accessories, whichever is the lesser, is to be tested. For individually produced, individually heat treated, accessories or accessories produced in small batches (less than 5), alternative testing is to be subject to special consideration. Alternative testing is to be

approved by the Society and the following additional conditions may apply.

- Alternative testing is described in a written procedure and manufacturing procedure specification (MPS).
  - A finite element analysis is provided at the break load and demonstrates that the accessory has a safety margin over and above the break load of the chain.
  - Strain age testing (as per approved procedure by the Society) is carried out on the material grade produced to the same parameters at the time of qualification.
  - If an accessory is of a large size that will make heat treating in batches unfeasible or has a unique design, strain gauges are to be applied during the proof and break load tests during initial qualification and during production. The strain gauge results from production are to be comparable with the results from qualification.
- A batch is defined as accessories that originate from the same heat treatment charge and the same heat of steel. Reference to [1.3] and [1.4].
  - The accessories that have been subjected to the break load test are to be destroyed and not used as part of an outfit, with the exceptions given in (e).
  - Where the accessories are of increased dimension or, alternatively, a material with higher strength characteristics is used, they may be included in the outfit at the discretion of the Society, provided that:
    - the accessories are successfully tested at the prescribed breaking load appropriate to the chain for which they are intended, and
    - it is verified by procedure tests that such accessories are so designed that the breaking strength is not less than 1,4 times the prescribed breaking load of the chain for which they are intended.
    - strain age properties have been carried out on the material grade produced to the same parameters.
    - strain gauges are to be applied during the break load test in the high stress locations to monitor that the strains stay within allowable limits.

### 1.8.3 Dimensions and dimensional tolerances (1/7/2011)

At least one accessory (of the same type, size and nominal strength) out of 25 is to be checked for dimensions after proof load testing. The Manufacturer is to provide a statement indicating compliance with the purchaser's requirements.

The following tolerances are applicable to accessories:

- Nominal diameter: + 5 percent, - 0 percent
- Other dimensions:  $\pm 2\frac{1}{2}$  percent.

These tolerances do not apply to machined surfaces.

### 1.8.4 Mechanical tests (1/7/2017)

Accessories are to be subjected to mechanical testing as described in [1.3] and [1.4].

Mechanical tests are to be taken from proof loaded full size accessories that have been heat treated with the production accessories they represent.

At least one accessory out of every batch or every 25 accessories, whichever is less, is to be tested. Hardness tests are to be carried out on finished accessories. The frequency and locations are to be agreed with the Society. The recorded values are for information only and used as an additional check to verify that the heat treatment process has been stable during the accessory production.

The use of separate representative coupons is not permitted except as indicated below.

Test location of forged shackles. Forged shackle bodies and forged Kenter shackles are to have a set of three impact tests and a tensile test taken from the crown of the shackle.

Tensile tests on smaller diameter shackles can be taken from the straight part of the shackle, where the geometry does not permit a tensile specimen from the crown. The tensile properties and impact values are to meet the requirements of Tab 3 in the locations specified in Fig 3, with the Charpy pieces on the outside radius.

The locations of mechanical tests of cast shackles and cast Kenter shackles can be taken from the straight part of the accessory. The tensile properties and impact values are to meet the requirements of Tab 3 in the locations specified in Fig 3.

The locations of mechanical tests of other accessories with complex geometries are to be agreed with the Society.

For non-circular sections,  $1/4t$  (thickness) from the surface is considered appropriate.

Rolled plates are to be tested to the Standard to which they are produced.

For individually (heat treated) produced accessories or accessories produced in small batches, (less than 5), alternative testing can be proposed to the Society and the following additional conditions may apply:

Each proposal for alternative testing is to be detailed by the manufacturer in a written procedure and submitted to the Society.

- a) If separately forged or cast coupons are used, they are to have a cross-section and, for forged coupon, a reduction ratio similar to that of the accessories represented, and are to be heat treated in the same furnace and quenched in the same tank at the same time, as the actual forgings or castings. Thermocouples are to be attached to the coupon and to the accessories.
- b) If separately forged or cast coupons are agreed, it is to be verified by procedure test that coupon properties are representative of accessory properties.

A batch is defined as accessories that originate from the same heat treatment charge and the same heat of steel. Reference to [1.3] and [1.4].

Mechanical tests of pins are to be taken as per Fig 3 from the mid length of a sacrificial pin of the same diameter as the final pin. For oval pins the diameter taken is to represent the smaller dimension. Mechanical tests may be taken from an extended pin of the same diameter as the final pin that incorporates a test prolongation and a heat treatment buffer

prolongation, where equivalence with mid length test values have been established.

The length of the buffer is to be at least equal to 1 pin diameter dimension which is removed after the heat treatment cycle is finished. The test coupon can then be removed from the pin. The buffer and test are to come from the same end of the pin as per Fig 5.

**Figure 5 : Buffer and test piece location (1/7/2011)**

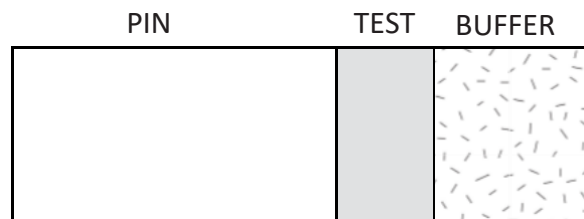

**1.8.5 Non-destructive examination after proofload testing (1/7/2017)**

All chain accessories are to be subjected to a close visual examination. Special attention is to be paid to machined surfaces and high stress regions. Prior to inspection, chain accessories are to have a suitably prepared surface as per the applied NDE testing standard. All non-machined surfaces are to be sand or shot blast to permit a thorough examination. Where applicable, accessories are to be dismantled for inspection of internal surfaces. All accessories are to be checked by magnetic particles or dye penetrant. UT of accessories may be required by the Society. The acceptance /rejection criteria of UT established for the design is to be met.

Testing is to be performed in accordance with a recognized Standard, such as those indicated below, or equivalent. The procedures, together with acceptance/rejection criteria are to be submitted to the Society for review.

Manufacturers are to prepare written procedures for NDE. NDE personnel are to be qualified and certified according to ISO 9712, ACCP or equivalent. Personnel qualification to an employer or responsible agency based qualification scheme as SNT-TC-1A may be accepted if the employer's written practice is reviewed and found acceptable and the Level III is ASNT Level III, ISO 9712 Level III or ACCP Professional Level III and certified in the applicable method. NDE operators are to be qualified to at least level II.

Magnetic particle testing (MT) of forgings:

- EN 10228-1, ASTM A275, using wet continuous magnetization technique or equivalent standards such as ISO 4986, IACS Rec 69

Ultrasonic testing (UT) of forgings:

- EN 10228-3, ASTM A388, ISO 13588

Magnetic particle testing (MT) of castings:

- ASTM E709, using wet continuous magnetization technique

Ultrasonic testing (UT) of castings:

- ASTM A609, ISO 13588

All surfaces are to be magnetic particle tested (MT). Testing is to be performed in accordance with standards referenced using the fluorescent technique. As a minimum surfaces are to be free from:

- relevant linear indications exceeding 1.6 mm in transverse direction
- relevant linear indications exceeding 3.2 mm in longitudinal direction
- relevant non-linear indications exceeding 4.8 mm.

When required by the Society, ultrasonic testing is to be carried out on 100% of cast or forged accessories. The acceptance/rejection criteria established for the design is to be met.

The Manufacturer is to provide a statement that non-destructive examination has been carried out with satisfactory results. This statement is to include a brief reference to the techniques and to the operator's qualification.

Weld repairs of finished accessories are not permitted.

### 1.8.6 Test failures

In the event of a failure of any test the entire batch represented is to be rejected unless the cause of failure has been determined and it can be demonstrated to the Surveyor's satisfaction that the condition causing the failure is not present in any of the remaining accessories.

### 1.8.7 Marking

Each accessory is to be marked as follows:

- Chain grade
- Certificate number

The Certificate number may be replaced by an abbreviation or equivalent. If so, this is to be stated on the certificate.

### 1.8.8 Documentation (1/7/2017)

A complete Inspection and Testing Report in booklet form is to be provided by the manufacturer for each order. This booklet is to include all dimensional checks, test and inspection reports, non-destructive examination reports, process records and example photographs of components positioned in furnaces, as well as any nonconformity, corrective action and repair work.

Each type of accessory is to be covered by a separate certificate.

All accompanying documents, appendices and reports are to carry reference to the original certificate number.

The Manufacturer is responsible for storing all documentation produced, in a safe and retrievable manner, for a period of at least 10 years.

## 1.9 Chafing Chain for Single Point Mooring arrangements

### 1.9.1 Scope (1/7/2011)

These requirements apply to short lengths (approximately 8m) of 76mm diameter chain to be connected to hawsers for the tethering of oil carriers to single point moorings, FPSO's and similar uses.

### 1.9.2 Approval of Manufacturing (1/7/2011)

The chafing chain is to be manufactured by works approved by the Society according to [1.1.3].

### 1.9.3 Materials (1/7/2011)

The materials used for the manufacture of the chafing chain are to satisfy the requirements of [1.2].

### 1.9.4 Design, manufacturing, testing and certification (1/7/2017)

The chafing chain is to be designed, manufactured, tested and certified in accordance with [1.3], [1.4] and [1.5], except that batch heat treatment is permitted.

The arrangement of the end connections is to be of an approved type.

The common link is to be of the stud link type – Grade R3 or R4.

The chafing chain is to be capable of withstanding the breaking test loads of 4884kN (Grade R3) and 6001kN (Grade R4). See Note 1.

The chain lengths shall be proof load tested in accordance with [1.7.2]. The test load for Grade R3 is 3242kN and for Grade R4 is 4731kN.

Note 1: Documented evidence of satisfactory testing of similar diameter mooring chain in the prior 6 month period may be used in lieu of break testing subject to agreement with classification society

Note 2: The requirements herein are also applicable to other diameter chafing chains, such as 84 mm and 96 mm, subject to compliance with the proof and break load requirements specified for the chain grade and diameters in Tab 5.